

ASG

PRODUCTS INC.

Air Conditioning System

Installation Manual

for

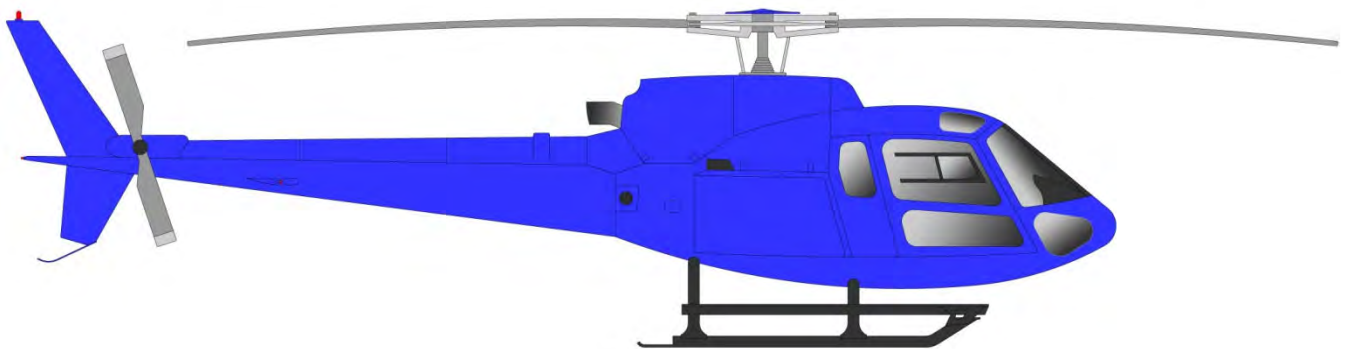

350-00-031-HP
AEC Basic Version

(Revised: April 22, 2024, Rev: AE)

1	KIT INVENTORY
2	AIRCRAFT PRE-INSPECTION
3	AIRCRAFT PREPARATION
4	REMOVAL OF FACTORY COMPONENTS
5	INSTALLATION OF AFT EVAPORATOR
6	INSTALLATION OF CONDENSER
7	INSTALLATION OF FWD EVAPORATOR
8	INSTALLATION OF COMPRESSOR
9	INSTALLATION OF ELECTRICAL
10	INSTALLATION OF HOSES
11	PAPERWORK
12	CONTINUED AIRWORTHINESS
13	PARTS BREAK DOWN
14	T&C/WARRANTY/RMA
15	TROUBLE SHOOTING GUIDE

RECORD OF REVISIONS

Revision	Description	Date	Revised By
IR	Initial Release	4 Nov. 2009	IFS
A	Revised Compressor Install	5 Feb. 2010	IFS
B	Updated Kit List	29 Jan. 2013	RSG
C	Updated Kit List	3 Mar. 2014	RSG
D	Formatted document to RSG Products	22 May. 2015	RSG
E	Updated sections 5, 7, and 9 and Kit List	28 Oct. 2015	RSG
F	Updated Kit List	24 Mar. 2016	RSG
G	Updated Kit List	28 Nov. 2017	RSG
H	Updated sections 1, 7, 8, & 9	14 Jan. 2019	RSG
J	Updated sections 1, 5, 7, 8, 9, & 12	12 Jun. 2019	RSG
K	Updated sections 1, 5, 7, 8, & 9	26 Nov. 2019	RSG
L	Updated Kit List section 1	20 Jan. 2020	RSG
M	Updated Kit List section 1	17 Mar. 2020	RSG
N	Updated MSDS section 1	4 June 2020	RSG
P	Updated Kit List section 1	3 Nov. 2020	RSG
Q	Updates sections 5, 6, & 9	3 July 2021	RSG
R	Update sections 1 & 7	11 Nov. 2021	RSG
T	Updated sections 5 & 7	18 Mar. 2022	RSG
U	Updated Kit List section 1 & drawing in section 7	28 Mar. 2022	RSG
V	Updated Kit List in section 1 & drawing in section 7	05 May 2022	RSG
W	Update drawings in section 5	26 May 2022	RSG
X	Updated sections 1, & 5-15	19 Aug. 2022	RSG
Y	Updated sections 1, 5-7, 8, 10-12, and 15	28 Nov. 2022	RSG
AA	Updated sections 1, 6-9, and 11	7 Feb. 2023	RSG
AB	Updated sections 1 & 9	21 Apr. 2023	RSG
AC	Updated section 9 to include VEMD info	2 June 2023	RSG
AD	Updated section 1 kit list	14 July 2023	RSG
AE	Updated sections 1, 5-8, 10-12, 13	22 April 2024	RSG

LIST OF EFFECTIVE PAGES

Rev	Section	Pgs	Description	Date
X	1	10	Updated 1-5-AS350 drawing	08/19/22

Y	1	10-11	Updated 1-5-AS350 drawing	11/28/22
AE	1	11	Updated 1-5-AS350 drawing	04/22/24
IR	1	Insert	Initial Release	11/04/09
B	1	Insert	Revised Kit Inventory List	01/29/13
C	1	Insert	Revised Kit Inventory List	03/03/14
D	1	Insert	Revised Kit Inventory List	05/22/15
E	1	Insert	Revised Kit Inventory List	10/28/15
F	1	Insert	Revised Kit Inventory List	03/24/16
G	1	Insert	Revised Kit Inventory List	11/28/17
H	1	Insert	Revised Kit Inventory List	01/14/19
J	1	Insert	Revised Kit Inventory List	06/12/19
K	1	Insert	Revised Kit Inventory List	11/26/19
L	1	Insert	Revised Kit Inventory List	01/20/20
M	1	Insert	Revised Kit Inventory List	03/17/20
P	1	Insert	Revised Kit Inventory List	11/3/20
R	1	Insert	Revised Kit Inventory List	11/11/21
U	1	12-26	Revised Kit Inventory List	03/28/22
V	1	12-26	Revised Kit Inventory List	05/05/22
X	1	11-25	Revised Kit Inventory List	08/19/22
AA	1	13-27	Revised Kit Inventory List	02/07/23
AB	1	13-27	Revised Kit Inventory List	04/21/23
AD	1	13-27	Revised Kit Inventory List	07/14/23
AE	1	12-26	Revised Kit Inventory List	04/22/24
N	1	27-30	Removed MSDS for touch-up paint	06/04/20
IR	2	1-4	Initial Release	11/04/09
IR	3	1-3	Initial Release	11/04/09
IR	4	1-2	Initial Release	11/04/09
IR	5	1-5	Initial Release	11/04/09
D	5	Insert	Updated drawings	05/22/15
E	5	Insert	Updated drawing	10/28/15
J	5	Insert	Updated drawing	06/12/19
K	5	Insert	Updated drawing	11/26/19
Q	5	45-50	Updated drawing	7/3/21
W	5	45-52	Updated 4-3-AS350 drawing	05/26/22
X	5	44-50	Updated 4-3-AS350 drawing	08/19/22
Y	5	44	Update instructions in Step 5.17 to remove resistor	11/28/22

Y	5	45-61	Updated 4-3-AS350, 4-13-AS350, & 5-10-AS350 drawings	11/28/22
AE	5	45-55	Updated 4-3-AS350, 4-13-AS350, 5-10-AS350, 5-21-AS350 & 3-5-AS350 drawings	04/22/24
X	5	52	Updated 5-10-AS350 drawing	08/19/22
T	5	56-58	Updated 5-21-AS350 drawing	03/18/22
W	5	56-59	Updated 5-21-AS350 drawing	05/26/22
Y	5	66-69	Updated 3-5-AS350 drawing	11/28/22
IR	6	1-5	Initial Release	11/04/09
D	6	Insert	Updated drawings	05/22/15
E	6	Insert	Updated drawing	10/28/15
Q	6	63-66	Updated drawing	07/3/21
X	6	63-64	Updated 7-22-AS350 drawing	08/19/22
X	6	67	Updated 7-25-AS350 drawing	08/19/22
Q	6	69-71	Updated drawing	07/3/21
Q	6	73-76	Updated drawing	07/3/21
X	6	69-70	Updated 7-28-AS350 & 7-29-AS350 drawing	08/19/22
Y	6	71	Added "if required" to end of p/n 261013	11/28/22
Y	6	73	Updated blower part number in Step 6.19	11/28/22
Y	6	75-77	Updated 7-22-AS350 drawing	11/28/22
AA	6	76-83	Updated 7-22-AS350, 7-23-AS350 & 7-24-AS350 drawings	02/07/23
AA	6	86-89	Updated 7-28-AS50 & 7-29-AS350 drawings	02/07/23
AE	6	57	Updated instructions in Step 6.2	04/22/24
AE	6	61-63	Updated 7-22-AS350, 7-23-AS350 & 7-24-AS350 drawings	04/22/24
AE	6	66-67	Updated 7-28-AS350 & 7-29-AS350 drawings	04/22/24
IR	7	1-2	Initial Release	11/04/09
D	7	3	Steps 7.9 and 7.10	05/22/15
D	7	Insert	Updated drawings	05/22/15
E	7	Insert	Updated drawing	10/28/15
H	7	Insert	Updated drawing	01/14/19
J	7	Insert	Updated drawing	06/12/19
K	7	Insert	Updated drawing	11/26/19
R	7	80-86	Update 4-21-AS350 drawing	11/11/21
T	7	82-91	Update 4-21-AS350 drawing	03/18/22
U	7	80	Added doubler to Step 7.5 & grommet to Step 7.7	03/28/22
V	7	82-91	Update 4-21-AS350 drawing	05/05/22

X	7	74-82	Updated 4-21-AS350, 5-26-AS350 & 5-10-AS350 drawings	08/19/22
X	7	72	Updated instructions in Step 7.7	08/19/22
Y	7	87-102	Updated 4-21-AS350, 5-26-AS350 & 5-10-AS350 drawings	11/28/22
AA	7	93-106	Updated 4-21-AS350 & 5-26-AS350 drawings	02/07/23
AE	7	71-79	Updated 4-21-AS350, 5-26-AS350, 5-10-AS350 & 5-21-AS350 drawings	04/22/24
A	8	1-5	Revised Instructions	02/05/10
D	8	4	Step 8.9	05/22/15
D	8	Insert	Updated drawings	05/22/15
H	8	Insert	Updated drawings	01/14/19
J	8	Insert	Updated drawing	06/12/19
K	8	Insert	Updated drawing	11/26/19
X	8	88-92	Updated 6-2-AS350 & 6-3-AS350 drawings	08/19/22
Y	8	113-117	Updated 6-3-AS350 drawing	11/28/22
AA	8	116	Revised instructions in Steps 8.5 and 8.7	02/07/23
AA	8	121-126	Updated 6-3-AS350 drawing	02/07/23
AE	8	86-91	Updated 6-3-AS350 drawing	04/22/24
IR	9	1-2	Initial Release	11/04/09
D	9	2	Steps 9.4, 9.6, & 9.7	05/22/15
D	9	Insert	Updated drawings	05/22/15
E	9	2	Step 9.2	10/28/15
E	9	Insert	Updated and add drawings	10/28/15
H	9	Insert	Updated drawings	01/14/19
J	9	Insert	Updated drawings	06/12/19
K	9	Insert	Updated drawing	11/26/19
Q	9	121-123	Updated drawing	07/3/21
X	9	99-102	Updated 2-19-AS350, 2-16-AS350 & 2-25-AS350 drawings	08/19/22
X	9	103-106	Updated 7-2-AS350 drawing (<i>for reference</i>)	08/19/22
AA	9	133-134	Added electrical checkout procedures for use with Steps 9.1 through 9.7	02/07/23
AB	9	133-134	Revised electrical checkout procedures	04/21/23
AC	9	133-134	Added note to electrical checkout procedures on setting the VEMD (if equipped)	06/02/23
IR	10	1-3	Initial Release	11/04/09
D	10	Insert	Updated drawings	05/22/15
Y	10	135-138	Updated 3-5-AS350 drawing	11/28/22

AE	10	111-114	Updated 3-5-AS350 drawing	04/22/24
IR	11	1-2	Initial Release	11/04/09
D	11	2	Updated to RSG	05/22/15
D	11	Insert	Updated STC Cover Sheet	05/22/15
D	11	Insert	Updated RFMS's	05/22/15
E	11	Insert	Updated RFMS's	10/28/15
Y	11	141	Updated weight & balance data	11/28/22
X	11	114-135	Updated STC & foreign applicability	08/19/22
AA	11	156	Moved foreign applicability to website (www.rotorcraftservices.com/customer-support)	02/07/23
X	11	136-147	Updated MDL	08/19/22
Y	11	177-225	Updated RFMS	11/28/22
AA	11	169	Moved RFMS's to website (www.rotorcraftservices.com/customer-support)	02/07/23
AE	11	117	Updated weight & balance page (revision change)	04/22/24
AE	11	122-133	Updated MDL	04/22/24
IR	12	1-12	Initial Release	11/04/09
D	12	Insert	Updated ICA	05/22/15
J	12	Insert	Updated ICA	06/12/19
X	12	242-347	Updated ICA to Rev F	08/19/22
Y	12	227-345	Updated ICA	11/28/22
AE	12	136-240	Updated ICA to Rev F-1	04/22/24
IR	13	1-5	Initial Release	11/04/09
D	13	1-5	Updated to RSG	05/22/15
X	13	348-353	Updated parts break down list	08/19/22
C	14	1-6	Warranty Revised	11/04/09
X	14	355-360	Updated warranty policy, removed warranty claim form & added new RMA form	08/19/22
AE	14	250-253	Updated warranty policy, warranty registration & RMA forms	04/22/24
IR	15	Insert	Initial Release	01/29/09
X	15	362-376	Updated TS guide with RSG logos & removed outdated information	08/19/22
Y	15	347-360	Updated TS guide	11/28/22

Getting Started

The air conditioning system installation instructions are laid out step-by-step starting with one (1) thru nine (9) for installation and ten (10) thru fifteen (15) for care and airworthiness, the instructions are designed to be easy – to – use.

The example below is designed to give you a basic overview of how the steps work.

Example: A. In the step below there is a number **5.1** The “**5**” stands for step 5 and the “**1**” stands for direction 1.

Installation of Aircraft Systems

Example: B. When the parts are called out in a step: **5.1**, locate the part and parts that go with this step (5.1). It is best to organize your parts by step numbers so they can be drawn from as needed.

Step	Procedure	Mech	Insp
5.1	Position the aft evaporator doubler, P/N 261370, on the upper transmission deck per the dimensions shown on drawing number 4-1EC130. Mark and remove all existing rivets, bolts, and nut plates to allow the doubler to sit flat on deck. (Ref photo 501)		

Should you have any questions, problems or need technical support, do not hesitate to call, fax, E-mail, or write us:

Phone: 1-888-545-8371 E-Mail: info@rotorcraftservices.com
Fax: 1-800-624-6603

RSG Products Inc.
REQUIRED TOOLS – AS350 Air-Conditioning

Required Tools

1.	Drill ¼ or 3/8 Capacity / Straight and 90 degrees
2.	Rivet Gun - #4 & #5 Rivet Set
3.	Blind Rivet Puller
4.	Assorted Drill Bits - 40, 30, 10, ¼, & 21
5.	Standard Wrenches - ¼, 1-¼
6.	Metric Wrenches - 5mm to 19mm
7.	Standard Sockets - ¼ to ¾ cap Ratchet & Extensions
8.	Metric Sockets - 5mm to 19mm
9.	Torque Wrench (For Coupling) 200 <u>inch</u> lbs
10.	Rotary File (Die Grinder)
11.	Drum Sander
12.	Hole Finder - #30 & #10
13.	Cleco - #30, #21 & #40
14.	C-Clamps – Vise Grip Clamps
15.	Wire Cutters
16.	Phillips Screw Driver
17.	Torque-Bite (For Belly Pan) Pan American Tool 170-10 & 170-8 Power Torque
18.	Common Screw Drivers
19.	Cape Chisel
20.	Center Punch
21.	6oz Ballpeen Hammer for Removing Rivets
22.	Assorted Bucking Bars
23.	Safety Wire .032
24.	Wire Twisters
25.	Steel Ruler
26.	Spring scale

RSG Products Inc.
REQUIRED TOOLS – AS350 Air-Conditioning

27.	Adjust Wrench Cap 1-1/2
28.	Vacuum Pump
29.	Gauge Manifold
30.	Nitrogen
31.	R-134A
32.	Blocks for Supporting Forward Engine
33.	Vacuum Cleaner
34.	Rivnut Puller

REVISION RECORD				
REV	DATE	DESCRIPTION OF CHANGE	APPVD. BY	REV. BY
A	08/16/00	DWG. NUMBER WAS 1-AS 350. IS NOW 1-5-AS350.		
B	03/27/02	CHANGED TO AUTOCAD, ADDED NOTE 1.		
C	09/09/09	REVISED TITLE BLOCK.		
D	09/01/14	CHANGED TITLE BLOCK AND REVISION BLOCK.		AJC
E	01/19/22	UPDATED FORWARD AIR OUTLETS, FORWARD EVAPORATOR, INSTRUMENT PANEL VIEWS & FOD DESCRIPTION PER ECO 0768.		SGB
F	08/04/23	INCORPORATED ECO 1172.		SGB

NOTES:
 1. AIR OUTLET CONFIGURATION WILL CHANGE ACCORDING TO VERSION ORDERED.

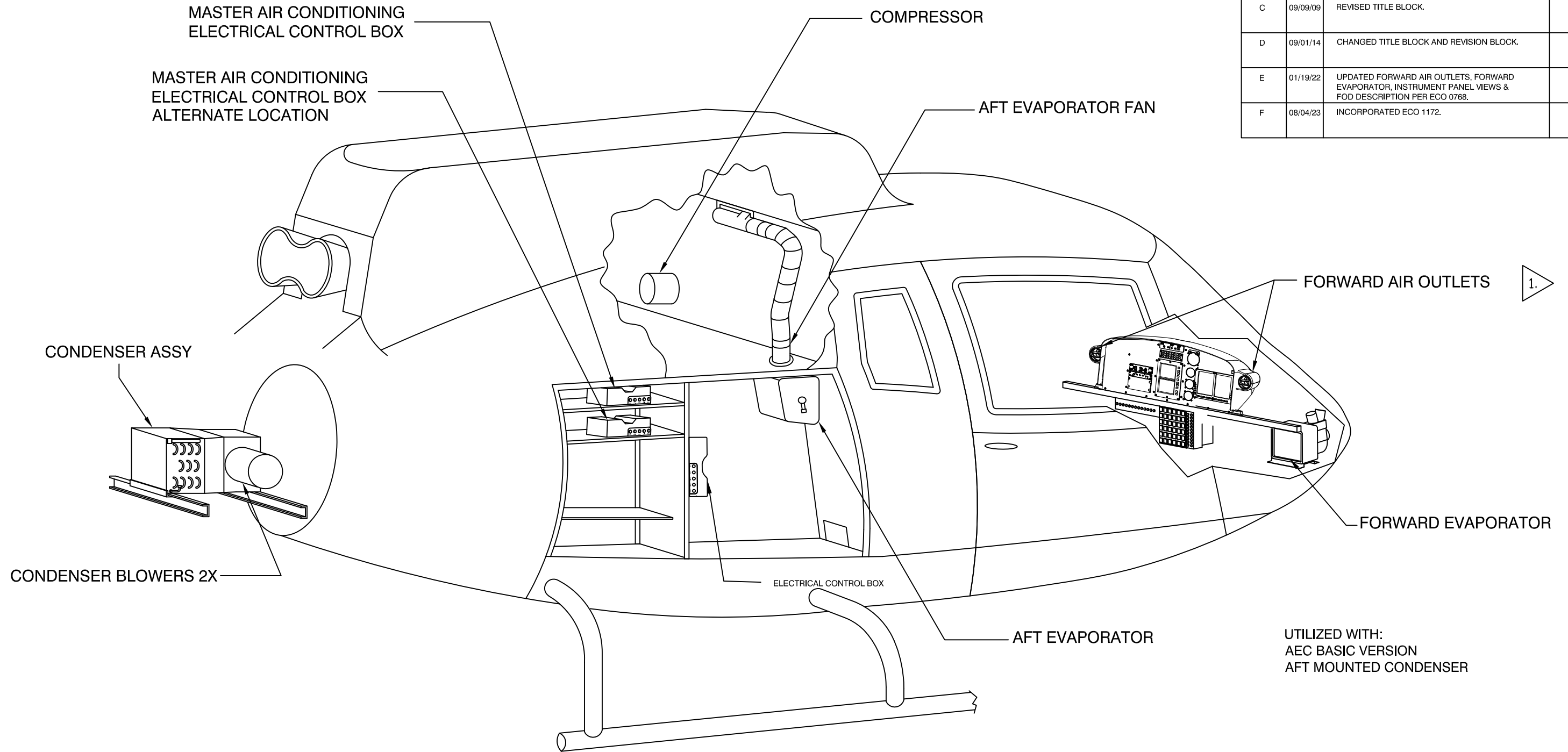

UTILIZED WITH:
 AEC BASIC VERSION
 AFT MOUNTED CONDENSER

PROPRIETARY NOTICE TO ALL PERSONS RECEIVING THIS DOCUMENT THIS DOCUMENT AND INFORMATION OR TECHNICAL DATA AND DESIGNS CONTAINED HEREIN ARE PROPRIETARY DATA AND EXCLUSIVE PROPERTY OF RSG PRODUCTS INC. AND IS DELIVERED ON THE EXPRESS CONDITION THAT NEITHER THIS DOCUMENT NOR THE INFORMATION CONTAINED HEREIN SHALL BE DISCLOSED TO OTHERS, REPRODUCED IN WHOLE OR IN PART, OR USED FOR THE MANUFACTURE OR FABRICATION OF PARTS FOR ANYONE OTHER THAN RSG PRODUCTS INC. WITHOUT WRITTEN CONSENT AND AUTHORIZATION, AND THAT NO RIGHT IS GRANTED TO DISCLOSE OR SO USE ANY INFORMATION CONTAINED IN SAID DOCUMENT. THIS RESTRICTION DOES NOT LIMIT THE RIGHT TO USE INFORMATION OBTAINED FROM ANOTHER SOURCE.	NEXT ASSY.	TOLERANCES EXCEPT AS SHOWN		
		.X: ±.1 .XX: ±.03 .XXX: ±.010 X.X": ±.5° BREAK ALL SHARP EDGES .01 ALL DIMENSIONS IN INCHES UNLESS OTHERWISE STATED		TITLE: AIR CONDITIONING OVERVIEW
	APPROVED BY:	DATE:	DRAWN BY: MAH	DATE: 11/10/96
			REV.: F	SCALE: N/A
			SHEET: 1 OF 1	
			APPLICATION: AS350	
			DWG. NO.: 1-5-AS350	



Step 1

Kit Inventory

P/N 350-00-031-HP

AEC Basic Version

(Rev. AD)

April 22, 2024



RECORD OF REVISIONS

Revision	Description	Date	Revised By
IR	Initial Release of Configuration	04, Nov. 2009	IFS
A	Removed Smooth Comp/Belt	02, Feb. 2010	IFS
B	Corrected Screw Callout Step 5.10/5.17	03, May 2010	IFS
C	Added Compressor Bracket Kit Upgrades	29, Jan 2013	RSG
D	Updated P/N's to page 14 and page numbers	3, March 2014	RSG
E	Updated P/N's and quantities	24 July 2014	RSG
F	Updated P/Ns and added alternate part numbers	16 Jan 2015	RSG
G	Added new alternate part numbers	11 May 2015	RSG
H	Removed items and corrected P/N's	14 Aug 2015	RSG
J	Added hardware to Section 9.2	20 Oct 2015	RSG
K	Added Alt. P/N Section 9.4	24 Mar 2016	RSG
L	Added 50A limiter	14 Jul 2016	RSG
M	Remove Alt. P/N	21 Oct 2016	RSG
N	Added hardware to Section 9.2	14 Jan 2019	RSG
P	Add rivets, hose clamp, and corrected hardware qty. for comp. bkt. kit	12 Jun 2019	RSG
Q	Changed p/n & removed parts from section 9.2	23 Jul 2019	RSG
R	Added alt. p/n of drain hose and grommet	21 Nov 2019	RSG
S	Updated air outlet assembly options, clamps and EMI filters	20 Jan 2020	RSG
T	Added 30 additional feet of foil tape in Step 5.16	17 Mar. 2020	RSG
U	Changed p/n for hose clamps in Step 5.21 & 6.20	09 Oct. 2020	RSG
V	Changed grommet & band clamp p/n in section 7	11 Nov. 2021	RSG
W	Added doubler & additional hardware to section 7.5	28 Mar. 2022	RSG
X	Updated hardware requirements in Step 7.5	5 May 2022	RSG
Y	Changed grommet p/n in Step 7.7	8 Aug. 2022	RSG
AA	Removed doubler from Step 6.2	7 Feb. 2023	RSG
AB	Updated drawing & document pages	21 Mar. 2023	RSG
AC	Updated grommet p/n in Step 7.7 and splice qty in Step 9.4	30 June 2023	RSG
AD	Updated compressor bracket kit part numbers	22 April 2024	RSG

LIST OF EFFECTIVE PAGES

Rev	Pgs	Description	Date
A	8	Removed P/N's 590008 and 060018-1	02/02/2010
B	5	MS35206-244 is now MS35206-230	03/05/2010
B	4	AN525-10R6 is now AN525-10R7	03/05/2010
C	13	Changed Kit List for: Compressor Bracket Installation Kit (Was: IFS-350/130-507, Is: 350-11-031-02)	01/29/2013
C	9	Added Hose Disconnect Bracket to Step 10.3 P/N: 04-130-21-107-01	01/29/2013
C	8	Changed P/N for Step 8.9 (Was: IFS-350/130-507, Is: 350-11-031-02)	01/29/2013
D	14	Added P/N's, removed 04-130-21-107-01 and adding it to step 10.3	03/03/2014
E	4	Corrected P/N in 5.10 ABA4-4 is now AD44ABS in step 5.10	07/24/2014



Air Conditioning System
Kit Part Number: 350-00-031-HP AEC Basic Version

E	6	Updated quantities of rivets MS20470AD-4-3, -4, and -5 to step 6.11	07/24/2014
E	9	Changed SD-507 Comp. Assy. To SD-507 Compressor Assy. (Grooved) in step 8.10	07/24/2014
E	9	Added option for smooth belt compressor P/N 590008 & smooth belt P/N 060018	07/24/2014
E	10	Changed p/n from 22CR4HM to ZZCR4HM in step 9.4	07/24/2014
F	4	Changed p/n from 1/16" i.d. to GM1 in step 5.4	01/16/2015
F	4	Changed part number from #8 x 1/2 to 050020-4 and #8 to 050020-5 in step 5.9	01/16/2015
F	9	Added alternate part numbers for fwd evap high and low hat assemblies	01/16/2015
F	10	Changed p/ns of electrical connectors from description to RSG p/ns steps 9.4 and 9.5	01/16/2015
G	9	Added new style vents and vent mounts in steps 7.9 and 7.10	05/11/2015
G	10	Added harness assy for micro switches in step 9.4	05/11/2015
G	10	Added new instrument panel & new aft switch assembly in steps 9.6 and 9.7	05/11/2015
H	6	Corrected P/N in step 5.17 490017-1 is now 490017-1-02. Removed Resistor.	08/14/2015
H	9	Replaced P/N 350-11-031-02 with note "SEE PAGE 14" in step 8.9	08/14/2015
H	11	Removed P/N 070003 in step 10.9	08/14/2015
H	14	Removed Kit P/N.	08/14/2015
J	10	Added hardware to section 9.2 for optional location for electrical control box.	10/20/2015
K	10	Added alternate P/N CR4HM in Step 9.4	03/24/2016
L	11	Added 50 AMP limiter in Step 9.5	07/14/2016
M	15	Remove Alt. P/N 261155 from Compressor Bracket Inst. Kit.	10/21/2016
N	9	Added alt. spacer to section 9.2 for optional location for electrical control box.	01/14/2019
P	5	Added 3 new rivets in step 5.4, quantity 30 each	06/12/2019
P	11	Add hose clamp p/n MS21919WDG13	06/12/2019
P	15	Update quantity of p/n MS21042-L4 from 2 to 3	06/12/2019
Q	9/10	Changed p/n & removed parts from section 9.2	07/23/2019
R	9	Added drain hose and grommet alt. p/n in step 7.7	11/21/2019
S	9	Update air outlet assy options in Step 7.9; changed vent mount note in Step 7.10	01/20/2020
S	11	Added alt. adel clamp p/n MS21919WDG14 qty 2 after Step 10.3	01/20/2020
S	12	Added EMI filter kit options for brushless motors after Step 10.9 & removed separate EMI filter and mounting hardware	01/20/2020
T	6	Added 30 more feet of p/n 070076 in Step 5.16 for total of 60 feet	03/17/2020
U	6/8	Changed hose clamp in Step 5.21 & Step 6.20 from 060035 to 060040	10/09/2020
V	9	Changed grommet p/n in Step 7.7 & band clamp in Step 7.8	11/11/2021
W	8	Added p/n 260373, grommet & additional hardware to Step 7.5	03/28/2022
X	8	Added 3 rivet sizes and reduced grommet from 3' down to 1.5'	05/05/2022
Y	9	Changed grommet p/n from MS35489-123 to MS35489-75	08/08/2022
AA	6	Removed Air Inlet Doubler L.H. p/n 261013 from Step 6.2	02/07/2023
AB	10	Updated ring terminals & splice part quantities in Step 9.4	03/21/2023
AB	13	Removed page/sheet number reference from Aft Evap drawing	03/21/2023
AB	14	Moved RFMS and Foreign Applicability to website & updated section 15 title	03/21/2023
AC	9	Changed grommet p/n from MS35489-75 to MS35489-72	06/30/2023
AC	10	Changed qty of 050020-8 in Step 9.4 from 8 to 10	06/30/2023
AD	15	Changed alt p/n for AN960-416, AN960-516L & AN960-616L	04/22/2024



Kit Configuration Inventory List: 350-00-031-HP AEC Basic Version

Customer Information

Sales Order Number:

Shipping Date:

Customer:

Customer P.O. Number:

Notes:

Kit Specifics

Kit S/N:

Condenser S/N:

Condenser Blower S/N:

Condenser Blower S/N:

Aft Evaporator Blower S/N:

Compressor S/N:



Kit Configuration Inventory List

STEP	PART NAME	PART NUMBER	QTY	CHK'D BY	VERF'D BY
5.1	Aft Evaporator Fan Doubler	260328-1	1		
5.4	Rivets	MS20470AD4-4	100		
5.4	Rivets	MS20470AD4-5	25		
5.4	Rivets	MS20470AD4-5.5	30		
5.4	Rivets	MS20470AD4-6	30		
5.4	Rivets	MS20426AD4-4	15		
5.4	Rivets	MS20426AD4-5	30		
5.4	Rivets	CR3243-4-03	2		
5.4	Caterpillar Grommet	GM1	1.5 ft.		
5.5	Aft Evaporator Assembly	560010-"O"-5	1		
5.5	Bolt	AN3-5A	4		
5.5	Washer	AN960-10	4		
5.6	Doubler, Return Air	260322-1	1		
5.8	Angle	260322-2	1		
5.8	Rivets	MS20470AD4-3	25		
5.8	Rivets	CR3243-4-03	25		
5.8	Rivets	CR3243-4-04	25		
5.8	Rivets	MS20470AD4-4	10		
5.8	Rivets	MS20426AD4-4	10		
5.9	Return Air Screen	080022-1	1		
5.9	Chrome Screw	050020-4	4		
5.9	Chrome Washer	050020-5	4		
5.10	Angle Return Air Connector Assembly	510261	1		
5.10	Rivets	AD44ABS	15		
5.10	Screw	AN525-10R7	2		
5.10	Return Air Cover Connector	250166	1		
5.11	Return Air Duct	250149	1		



Kit Configuration Inventory List

STEP	PART NAME	PART NUMBER	QTY	CHK'D BY	VERF'D BY
5.15	Rivnut	A10K80	3		
5.15	Screws	AN525-10R6	3		
5.15	Screws	AN525-10R10	4		
5.15	Clip Nut (Alt P/N: 13100000-5)	RM52LHA4972-10-02	4		
5.16	Aluminum Foil Tape	070076	60 ft.		
5.16	Cork Insulation Tape	070078-0	6 ft.		
5.17	Aft Evaporator Fan Assy. (Brushless)	490017-1-02	1		
5.17	Bolt	AN3-5A	5		
5.17	Washer	AN960-10	5		
5.18	Aft Transition Elbow Assembly	520036-3	1		
5.20	Bolt	AN3-6A	6		
5.20	Nut	MS21044N3	6		
5.20	Washer	AN960-10	12		
5.20	Transition Elbow Strap	261299	1		
5.21	4" Band clamp	060040	2		
5.21	Ø5.0" Duct 25" Long	060004	25 in		
5.21	Insulation Foam Tape	070078	20 ft.		
5.22	Air Duct Closure Assembly	510092	1		
5.23	Hose Doubler, Baggage Comp.	260369	1		
5.23	Rivets	MS20470AD4-4	10		
6.2	Air Inlet Doubler R.H.	261013-2	1		
6.7	Stringer	261012	4		



Kit Configuration Inventory List

STEP	PART NAME	PART NUMBER	QTY	CHK'D BY	VERF'D BY
6.8	Rivets	MS20470AD4-3	160		
6.8	Rivets	MS20470AD4-4	160		
6.8	Rivets	MS20470AD4-5	160		
6.10	Strap	261014	2		
6.10	Screen	080040	2		
6.10	Screw	AN525-832R8	12		
6.10	Washer	AN960-8	18		
6.10	Nut	MS21044N08	6		
6.10	Rivnut	MS27130-A13K	6		
6.11	R.H. Air Exit Doubler (Alt: 261100)	261100-1	1		
6.11	L.H. Air Exit Doubler (Alt: 261101)	261101-1	1		
6.11	L.H. Strap	261511	1		
6.11	R.H. Strap	261512	1		
6.11	Filler	261513	4		
6.11	UPPER FILLER STRIP	261094	2		
6.11	LOWER FILLER STRIP	261095	2		
6.11	ANGLE, UPPER, R.H.	261096	1		
6.11	ANGLE, UPPER, L.H.	261097	1		
6.11	ANGLE, LOWER, R.H.	261098	1		
6.11	ANGLE, LOWER, L.H.	261099	1		
6.11	Rivets	MS20470AD5-3	25		
6.11	Rivets	MS20470AD5-4	40		
6.11	Rivets	MS20470AD5-5	40		
6.11	Rivets	MS20470AD5-6	20		
6.11	Rivets	MS20470AD4-3	40		
6.11	Rivets	MS20470AD4-4	60		
6.11	Rivets	MS20470AD4-5	60		
6.11	Rivets	MS20470E5-6	70		
6.11	Rivets	MS20470E5-7	70		
6.12	Channel Fwd.	261080	1		
6.13	Channel Aft.	261081	1		



Kit Configuration Inventory List

STEP	PART NAME	PART NUMBER	QTY	CHK'D BY	VERF'D BY
6.14	Bolts	AN4-5A	8		
6.14	Washer	AN960-416	16		
6.14	Nut	MS21044N4	8		
6.15	Condenser Assembly	550022	1		
6.16	Bolt	AN3-5A	4		
6.16	Washer	AN960-10	8		
6.16	Nut	MS21044N3	4		
6.17	Air Exit Collar	250324	2		
6.17	Screw	AN525-832R12	8		
6.17	Washer	AN960-8	16		
6.17	Nut	MS21044N08	8		
6.17	Screen	080039	2		
6.19	.25" Heat Shrink	070077	24 in		
6.20	Ø5.0" Duct 8" Long	060004	2		
6.20	4" Band Clamp	060040	4		
6.21	Close out Panel	250301	1		
7.3	Forward Evaporator Assembly*** (Config. -01 Low Hat Config. -02 High Hat)	560025-"O"	1		
7.4	Nut Plate	MS21059-L3	1		
7.4	Rivet	CCR264SS3-03	3		
7.5	Doubler	260373-1	1		
7.5	Rivets	CR3243-4-03	18		
7.5	Caterpillar Grommet	GM1	1.5 ft.		
7.5	Doubler	260373	1		
7.5	Rivets	CR3212-4-02	4		
7.5	Rivets	CR3213-4-02	2		
7.5	Rivets	CR3213-4-03	2		



Kit Configuration Inventory List

STEP	PART NAME	PART NUMBER	QTY	CHK'D BY	VERF'D BY
7.7	3/8" Drain Hose (Alt: 090018-1 1/2" Drain Hose)	090018	10 ft.		
7.7	Grommet	MS35489-72	1		
7.8	Bolt	AN3-4A	4		
7.8	Washer	AN960-10	4		
7.8	Band Clamp 1"	61434114	1		
7.8	Nut	MS21044N3	3		
7.9	Air Outlet Assembly	510259-3	2		
7.9	Air Outlet Assy. L.H.*** (optional upgrade @ additional cost)	520156HP	1		
	Air Outlet Assy. R.H.*** (optional upgrade @ additional cost)	520157HP	1		
7.10	Rivet	CR3243-4-04	6		
7.10	Vent Mount (for optional air outlet upgrade)	261335HP-01	2		
	Screw	AN525-832R8	6		
	Nutplate	MS21042L08	4		
7.11	3" Band Clamp	060036	5		
7.11	Duct Ø2.5" X 120" Long	060025	1		
8.5	4 Groove Belt***	060005	2		
8.5	Smooth Belt*** (Alt. P/N: 060018)	060018-1	2		
8.9	Compressor Bracket Kit	SEE PAGE 15	1		
8.10	SD-507 Compressor Assy.(Grooved)***	590008-1	1		
8.10	SD-507 Compressor Assy. (Smooth)***	590008	1		
9.2	Electrical Box	540028-C-1-A	1		
9.2	Bolt ***	AN3-7A	3		
9.2	Washer ***	AN960-10	3		
9.2	Spacer ***	NAS43DD3-32FC	3		
For Alt. Location for Electrical Control Box ***					



Kit Configuration Inventory List

STEP	PART NAME	PART NUMBER	QTY	CHK'D BY	VERF'D BY
9.2	Rivets	CR3243-4-03	30		
9.2	Screw	AN507-1032R10	6		
9.2	Washer	AN960-10	9		
9.2	Nut	MS21044N3	6		
9.2	Rivet	MS20470AD4-10	40		
9.2	Bolt	AN3-4A	3		
9.3	Washer	AN960-10	8		
9.3	Nut	MS21044N3	4		
9.3	Screws	AN525-10R8	4		
9.4	Tie Wrap	10" Length Min.	200		
9.4	Tie Block (Alt. P/N: CR4HM)	ZZCR4HM	25		
9.4	Butt Splice 16-14	050020-1	4		
9.4	Ring Terminal 16-14	MS25036-106	4		
9.4	Knife Splice 22-16	050020-6	2		
9.4	Ring Terminal 16-14 #10	050020-8	4		
9.4	Knife Splice 16-14	050020-2	10		
9.4	Electrical Harness Assembly***	540044-3	1		
	(Config. -01 for non-microswitch Config. -02 for microswitch)				
9.5	Harness Assembly	540045-1	1		
9.5	Ring Terminal 8GA #10	050020-9	1		
9.5	Limiter 50 AMP	ANL-50	1		
9.6	Instrument Panel Switch***	540044-8	1		
	(Config. -01 for non-microswitch Config. -02 for microswitch)				
	Dzus Rail for -02 Switch Assembly	261348HP-01	2		
	Rivets	MS20426AD4-7	6		
9.7	Aft Switch Assembly***	540089	1		
	(Config. -01 for non-microswitch Config. -02 for microswitch)				



Kit Configuration Inventory List

STEP	PART NAME	PART NUMBER	QTY	CHK'D BY	VERF'D BY
10.3	Hose Assy Fwd Evap to Aft. Evap To Comp	570087-"O"-A	1		
10.3	#10 "O" Ring	090094	3		
10.3	Adel Clamp	MS21919WDG12	6		
10.3	Nut	MS21044N3	6		
10.3	Screw	AN525-10R10	6		
10.3	Washer	AN960-10	12		
10.3	Hose Disconnect Bracket	04-130-21-107-01	2		
10.3	Adel Clamp	MS21919WDG13	2		
	Adel Clamp (alternate)	MS21919WDG14	2		
10.4	Hose Assy. #6 Fwd. Evap. To Drier	570072-"O"-A	1		
10.4	#6 "O" Ring	090092	2		
10.4	Adel Clamp	MS21919WDG10	6		
10.4	Nut	MS21044N3	6		
10.4	Screw	AN525-10R10	6		
10.4	Washer	AN960-10	12		
10.6	Hose Assembly #8 Comp. Discharge	570070-"O"-A	1		
10.6	#8 "O" Ring	090093	3		
10.6	Adel Clamp	MS21919WDG11	4		
10.6	Nut	MS21044N3	4		
10.6	Screw	AN525-10R10	4		
10.6	Washer	AN960-10	8		
10.6	Hose Assembly #6 Condenser to Drier	570067-"O"-A	1		
10.6	#6 "O" Ring	090092	3		
10.6	Adel Clamp	MS21919WDG10	4		
10.6	Nut	MS21044N3	4		
10.6	Screw	AN525-10R10	4		
10.6	Washer	AN960-10	8		



Kit Configuration Inventory List

STEP	PART NAME	PART NUMBER	QTY	CHK'D BY	VERF'D BY
10.7	Receiver/Drier Bottle "O" Type	090016-5	1		
10.7	Band Clamp 3"	060036	1		
10.7	Rec/Drier Mount Bracket	260123-2	1		
10.7	Bolt	AN3-5A	2		
10.7	Nut	MS21044N3	2		
10.7	Washer	AN960-10	4		
10.9	Low Pressure Switch	050107	1		
10.9	High Pressure Switch	090004	1		
	Spiral Wrap Ø3/4"	SW12BKV	12 ft.		
	Aft Evap EMI Filter Kit *** (optional - for brushless motors)	050143-2	1		
	Tail Boom Condenser EMI Filter Kit *** (optional - for brushless motors)	050143-3	1		

** Indicates is utilized for new style only.

*** Indicates it has alternate or optional configuration.



DRAWING LIST

DRAWING NAME	DRAWING #	QTY	CHK'D BY	VERF'D BY
AIR CONDITIONING OVERVIEW	1-5-AS350	1		
ELECTRICAL ROUTING	2-19-AS350	1		
ELECTRICAL DIAGRAM	2-16-AS350	1		
ELECTRICAL DIAGRAM	2-25-AS350	1		
PLUMBING DIAGRAM	3-5-AS350	1		
PLUMBING DIAGRAM	3-15-AS350	1		
AFT EVAPORATOR INSTALL	4-3-AS350	1		
AFT EVAPORATOR INSTALL	4-13-AS350	1		
FORWARD EVAPORATOR INSTALL	4-21-AS350	1		
AIR DISTRIBUTION	5-26-AS350	1		
AIR DISTRIBUTION	5-10-AS350	1		
AIR DISTRIBUTION	5-21-AS350	1		
COMPRESSOR INSTALLATION	6-2-AS350	1		
COMPRESSOR INSTALLATION	6-12-AS350	1		
COMPRESSOR INSTALLATION	6-21-AS350	1		
COMPRESSOR INSTALLATION*	6-3-AS350*	1*		
COMPRESSOR INSTALLATION*	6-13-AS350*	1*		
COMPRESSOR INSTALLATION*	6-22-AS350*	1*		
CONDENSER INSTALL	7-22-AS350	1		
L.H. AIR EXIT DOUBLER INSTALL	7-23-AS350	1		
R.H. AIR EXIT DOUBLER INSTALL	7-24-AS350	1		
INSTALLATION, AIR INLET DBLR L.H.	7-25-AS350	1		
INSTALLATION, AIR INLET DBLR R.H.	7-26-AS350	1		
R.H. AIR EXIT DOUBLER INSTALL	7-28-AS350	1		
L.H. AIR EXIT DOUBLER INSTALL	7-29-AS350	1		

* Indicates drawings required for newer Gimbal Housing design



DOCUMENT LIST

DOCUMENT DESCRIPTION	LOCATION	QTY	CHK'D BY	VERF'D BY
KIT CONFIGURATION INVENTORY LIST (IFS 33.41)	SECTION 1	1		
MAT'L SAFETY DATA SHEETS	SECTION 1	1 EA.		
AIRCRAFT PRE-INSPECTION	SECTION 2	1		
AIRCRAFT PREPERATION	SECTION 3	1		
REMOVAL OF FACTORY INSTALLED COMPONENTS	SECTION 4	1		
INSTALLATION OF AFT EVAPORATOR	SECTION 5	1		
INSTALLATION OF CONDENSER	SECTION 6	1		
INSTALLATION OF FORWARD EVAPORATOR	SECTION 7	1		
INSTALLATION OF COMPRESSOR	SECTION 8	1		
INSTALLATION OF ELECTRICAL	SECTION 9	1		
INSTALLATION OF HOSES	SECTION 10	1		
STC# SH3509SW	SECTION 11	1		
WEIGHT AND BALANCE	SECTION 11	1		
INSTRUCTIONS FOR CONTINUED AIRWORTHINESS	SECTION 12	1		
MASTER PARTS LIST	SECTION 13	1		
ILLUSTRATED PARTS CATALOG	SECTION 13	1		
WARRANTY AND REPAIR	SECTION 14	1		
TROUBLE SHOOTING GUIDE	SECTION 15	1		
AIR CONDITIONING SCHEMATIC	SECTION 15	1		



COMPRESSOR BRACKET INSTALLATION KIT

ITEM DESCRIPTION	Part Number	QTY	Comment	CHK'D BY	VERF'D BY
COMPRESSOR MOUNT BRACKET	04-130-21-101-01	1			
COMPRESSOR MOUNT TENSION BOLT	04-130-21-102-01	1			
JAM NUT DRILLED	04-130-21-104-01	2			
COMPRESSOR CLAMP	04-130-21-105-01	2			
BUSHING, SD 507	261007	2			
COMPRESSOR STAND OFF	300067-1	1			
SHIM	300363-2	2			
THREADED ROD END	2434K39	1			
PIN	300095	1			
STRAP HOUSING	530100-1	1			
WASHER	NAS1149D0416H	1	Or NAS Hardware equivalent		
WASHER	NAS1149D0632H	6	Or NAS Hardware equivalent		
WASHER	NAS1149D0532H	2	Or NAS Hardware equivalent		
WASHER	AN960-416	4	Alternate (NAS1149F0463P)		
WASHER	AN960-516L	1	Alternate (NAS1149F0532P)		
WASHER	AN960-616L	2	Alternate (NAS1149F0632P)		
NUT	MS21042-L5	2	Alternate (MS20364-524C)		
NUT	MS21042-L4	3	Alternate (AN365-424)		
NUT	MS21042L6	4	Or NAS Hardware equivalent		
BOLT	AN4-5A	1	Or NAS Hardware equivalent		
BOLT	AN4-14A	2	Or NAS Hardware equivalent		
BOLT	AN5-34A	1	Or NAS Hardware equivalent		
BOLT	AN6-13A	2	Or NAS Hardware equivalent		
BOLT HEX DRIVE	AN6-12	1	Or NAS Hardware equivalent		
BOLT	AN6-33A	1	Or NAS Hardware equivalent		

MATERIAL SAFETY DATA SHEET

Trade Name: Johnsen's Ester 100
MSDS NO. 6711
Revision Date: 03/26/2007
Date Printed: 12/30/2008

1. CHEMICAL PRODUCT AND COMPANY IDENTIFICATION

Trade Name: Johnsen's Ester 100
Chemical Family: Refrigeration Oil
Synonyms: None
Emergency Telephone (24 hr.): CHEMTREC 1-800-424-9300

Supplier: Technical Chemical Company, P.O. Box 139, Cleburne, Texas 76033

2. COMPOSITION/INFORMATION ON INGREDIENTS

Component	Weight %	OSHA TWA	OSHA STEL	OSHA SKIN
Ester Proprietary Inhibitor Package Mixture	0-20	Not Listed	Not Listed	Not Listed
Ester Proprietary Base Stock Mixture	20-80	Not Listed	Not Listed	Not Listed

Component	Weight %	OSHA Z PEL	OSHA Z TWA	OSHA Z Ceiling
Ester Proprietary Inhibitor Package Mixture	0-20	Not Listed	Not Listed	Not Listed
Ester Proprietary Base Stock Mixture	20-80	Not Listed	Not Listed	Not Listed

Component	ACGIH TLV TWA	ACGIH TLV STEL	ACGIH TLV Ceiling
Ester Proprietary Inhibitor Package Mixture	Not Listed	Not Listed	Not Listed
Ester Proprietary Base Stock Mixture	Not Listed	Not Listed	Not Listed

Other: Contains no ingredients in concentrations greater than 0.1% that are now known to be hazardous as defined by OSHA.

3. HAZARDS IDENTIFICATION

Emergency Overview: Ingestion of this product may cause gastrointestinal distress with symptoms of nausea, vomiting, diarrhea and abdominal pain. May cause irritation to skin and eyes.

HMIS Classification: Health: 1 Flammability: 1 Physical Hazard: 0
NFPA Rating: Health: 1 Flammability: 1 Reactivity: 0

4. FIRST AID MEASURES

Eye Contact: In case of contact, immediately flush eyes with plenty of water for at least 15 minutes, occasionally lifting the upper and lower lids. Seek medical attention if irritation persists.
Ingestion: DO NOT INDUCE VOMITING. Give nothing by mouth. Get medical attention! If vomiting occurs, keep head lower than hips to prevent aspiration.
Inhalation: If inhaled, remove to fresh air. If not breathing give artificial respiration, preferably mouth-to-mouth. If breathing is difficult give oxygen. Get medical attention.
Skin Contact: Remove contaminated clothing and shoes, and launder before reuse. Get medical attention if irritation persists. Wash with soap and water. Use skin cream for defatted areas.

MATERIAL SAFETY DATA SHEET

Trade Name: Johnsen's Ester 100
MSDS NO. 6711
Revision Date: 03/26/2007
Date Printed 12/30/2008

5. FIRE FIGHTING MEASURES

Flammable Properties

Flash Point °F(°C): >482 (<250)
Flash Point Method: COC
Flammable Limits in Air - Lower (%): Not Determined
Flammable Limits in Air - Upper (%): Not Determined
Autoignition Temperature °F(°C): Not Determined
Extinguishing Media: Carbon dioxide. Dry chemical. Foam.
Protection Of Fire-Fighters:

Special Fire-Fighting Procedures: Wear approved positive-pressure self-contained breathing apparatus and protective clothing. Do not direct a solid stream of water or foam into hot, burning pools; this may cause frothing and increase fire intensity.
Hazardous Combustion Products: Oxides of carbon, nitrogen and phosphorus.
Aerosol Comments: Not Applicable

6. ACCIDENTAL RELEASE MEASURES

Personal Precautions: Wear appropriate protective clothing and equipment to prevent skin and eye contact.
Spill Procedures: Wear protective equipment specified. Contain any liquid from leaking containers.
Action to be taken if material is released or spilled: Absorb spills on inert material such as perlite, vermiculite, sand or dirt. Place in double polyethylene bags. Isolate from other waste materials. Wash walking surfaces with detergent and water to reduce slipping hazard.
Environmental Precautions: Do not allow to enter sanitary drains, sewer or surface and subsurface waters.

7. HANDLING AND STORAGE

Handling and Storage: Avoid contact with eyes. Keep containers tightly closed when not in use. Use only in a well ventilated area. Good hygienic practices should be observed. Work clothes should be washed separately at the end of each work day. Contaminated disposable clothing should be discarded in accordance with local, state and federal rules. Wash thoroughly after handling. Do Not Swallow. Store at room temperature. Avoid prolonged/repeated breathing of vapors, mists or fumes.

8. EXPOSURE CONTROLS/PERSONAL PROTECTION

Engineering Controls: Eyewash stations. Showers. Use local exhaust.
Eyes: Chemical goggles; also wear a face shield if splashing hazard exists.
Skin Protection: Neoprene coated apron or clothing.
Respiratory Protection: Appropriate respiratory protection shall be worn when applied engineering controls are not adequate to protect against inhalation exposure.

9. PHYSICAL AND CHEMICAL PROPERTIES

Appearance: Clear to light yellow liquid
Odor: MILD ETHER
pH Value: Not Determined
Vapor Pressure: Not Determined
Vapor Density (Air=1): Not Determined
Boiling Point (°F): >300 C.
Melting/Freezing Point: Not Determined
Solubility in Water: INSOLUBLE
Bulk Density at 20°C: Not Determined
Molecular Weight: Mixture
Specific Gravity (H2O=1): 1.04 @ 60F
Viscosity: 100 cSt @ 40C
Evaporation Rate: Not Determined
VOC Content(%): Not determined.
Decomposition Temperature: Not Known

MATERIAL SAFETY DATA SHEET

Trade Name: Johnsen's Ester 100
MSDS NO. 6711
Revision Date: 03/26/2007
Date Printed: 12/30/2008

10. STABILITY AND REACTIVITY

Chemical Stability: Stable under normal conditions of handling, use and transportation.
Conditions to Avoid: High temperatures.
Materials to Avoid: Strong oxidizing agents.
Hazardous Decomposition Products: Oxides of nitrogen. Oxides of carbon. Oxides of sulfur.
Hazardous Polymerization: WILL NOT OCCUR

11. TOXICOLOGICAL INFORMATION

Toxicological Data:

Component	Route	Species	Dose
Ester Proprietary Inhibitor Package Mixture	Inhalation	Rats	Not known.
Ester Proprietary Base Stock Mixture	Inhalation	Rats	Not known.

Carcinogenicity:

Component	IARC	NTP	OSHA
Ester Proprietary Inhibitor Package Mixture	Not Listed	Not Listed	Not Listed
Ester Proprietary Base Stock Mixture	Not Listed	Not Listed	Not Listed

Comments: No component known to be present in this product at >.1% is presently listed as a carcinogen by IARC, NTP or OSHA.

12. ECOLOGICAL INFORMATION

Remarks: Ecological testing has not been conducted on this product.

13. DISPOSAL CONSIDERATION

Waste Classification: This product as purchased does not fall under current U.S. EPA RCRA definitions of hazardous waste. Under RCRA it is the generator's responsibility to determine the status of the waste at the time of its disposal. This product does not contain any CERCLA regulated materials.
Waste Management: Not determined.
Disposal Method: Disposal of this material to the land may be banned by federal law (40 CFR 268).

14. TRANSPORTATION INFORMATION

U.S. DOT:
Proper Shipping Name: Not Regulated
Hazard Class: Not Applicable
UN/NA Number: Not Applicable
DOT Packing Group: Not Applicable

IMDG:
Proper Shipping Name: Not Regulated
Hazard Class: Not Applicable
Hazard Subclass: Not Applicable
UN No.: Not Applicable
Packing Group: Not Applicable
Marine Pollutant: No

MATERIAL SAFETY DATA SHEET

Trade Name: Johnsen's Ester 100
 MSDS NO. 6711
 Revision Date: 03/26/2007
 Date Printed: 12/30/2008

15. REGULATORY INFORMATION

US Federal Regulations:

Component	SARA 313	SARA 302	TPQ	RQ
Ester Proprietary Inhibitor Package Mixture	Not Listed	Not Listed	Not Listed	Not Listed
Ester Proprietary Base Stock Mixture	Not Listed	Not Listed	Not Listed	Not Listed

US OSHA HEALTH CLASSIFICATION: Hazardous per OSHA 29 CFR 1910.1200
SARA 311/312 Hazard Categories: Immediate Health: Yes, Delayed Health: No, Fire: No, Reactive: No, Pressure: No.

State Regulations:

Component	California Prop. 65 Cancer list	California - Prop 65 Developmental Toxicity	California Prop. 65 Reproductive Female	California Prop. 65 Reproductive Male
Ester Proprietary Inhibitor Package Mixture	Not Listed	Not Listed	Not Listed	Not Listed
Ester Proprietary Base Stock Mixture	Not Listed	Not Listed	Not Listed	Not Listed

U.S. TSCA: One or more components of this product is not listed on the TSCA Inventory.
Canadian Inventory: One or more components of this product is not listed on the Canadian DSL or NDSL Inventory.

Consumer Product Safety Improvement Act of 2008 General Conformity Certification

The Supplier identified in Section 1 of this MSDS has evaluated this product and certifies it to be labeled and packaged in compliance with the applicable provisions of the Federal Hazardous Substance Act as stated in 16 CFR 1500 and enforced by the Consumer Product Safety Commission, and where applicable the products that require Child Resistant Closures are packaged in accordance with the Poison Prevention Packaging Act as stated in 16 CFR 1700 and enforced by the Consumer Product Safety Commission. All closures have been tested in accordance with the latest protocols. No other testing is required to certify compliance with the above. The date of manufacture is stamped on the product container.

16. OTHER INFORMATION

General Notes:
Disclaimer: Do not allow undiluted material or large quantities to reach groundwater, bodies of water or sewer system. The information and recommendations contained herein are based upon tests believed to be reliable. However, the manufacturer/distributor of this product does not guarantee their accuracy or completeness NOR SHALL ANY OF THIS INFORMATION CONSTITUTE A WARRANTY, WHETHER EXPRESSED OR IMPLIED, AS TO THE SAFETY OF THE GOODS, THE MERCHANTABILITY OF THE GOODS, OR THE FITNESS OF THE GOODS FOR A PARTICULAR PURPOSE. Adjustment to conform to actual conditions of usage may be required. The manufacturer/distributor assumes no responsibility for results obtained or for incidental or consequential damages, including lost profits, arising from the use of these data. No warranty against infringement of any patent, copyright or trademark is made or implied.

Step 2

Aircraft Pre-Inspection

Aircraft Pre-Inspection

STEP	PROCEDURE	MECH	INSP
2.1	Inspect the aircraft for other kits and Modifications that may effect the installation of The air conditioning kit.		
2.2	Inspect the airframe structure for any obvious Structural damage or corrosion.		
2.3	Repair discrepancies that are found prior to Installation of kit.		
2.4	Inspect aircraft paperwork for damage history that may effect the installation of this kit.		

General Safety Instructions

PROCEDURE

WARNING: Always handle the refrigerant fluids carefully.

WARNING: Do not mix other refrigerant fluids with the R134a. Do not use refrigerant canned for pressure-operated accessories (such as boat air horns). This refrigerant is not pure and will cause malfunctions in the system.

WARNING: When the system must be opened to do maintenance, before you do the work, you must drain the air conditioning system.

WARNING: When you open the system, you must collect the refrigerant in accordance with Federal and Local regulations.

WARNING: When the R134a is used in normal conditions, it is not flammable. Do not use it near a source of heat to prevent the risk of separation of the vapors.

WARNING: Avoid skin and eye contact with R-134a. The liquid R-134a, at normal atmospheric temperatures evaporates so quickly that it will freeze anything it comes in contact with.

WARNING: Wear safety goggles when servicing any part of the refrigerant system.

WARNING: Never heat a R-134a supply cylinder to produce additional pressure or attempt to empty the container completely.

WARNING: Insure adequate ventilation when servicing the refrigerant system.

WARNING: If the R-134a and lubrication oil are mixed with water they make hydrochloric acid. This will cause corrosion of the system components.

General Safety Instructions

PROCEDURE
<p><u>WARNING:</u> You must replace the filter drier each time you open the system.</p>
<p><u>WARNING:</u> Comply with the regulations in force in the country where the aircraft is operated when working on the air conditioning system.</p>
<p><u>WARNING:</u> Only use nitrogen or Alcohol to clean the system components.</p>
<p><u>WARNING:</u> Always keep the R-134a supply cylinder in an upright position when admitting refrigerant into the system. If a cylinder is on its side or upside down, liquid will enter the R-134a system and cause damage to the compressor.</p>

Step 3

Aircraft Preparation

Aircraft Preparation

STEP	PROCEDURE	MECH	INSP
3.0	Remove or disconnect the battery.		
3.1	Remove pilot and co-pilots doors.		
3.2	Remove right rear door as needed.		
3.3	Remove rear seats.		
3.4	Remove co-pilot anti-torque pedals.		
3.5	Drop the cabin headliner.		
3.6	Remove the two side screws from both sides of the glare shield.		
3.7	Remove back wall covering.		
3.8	Remove the right side baggage door.		
3.9	Remove the forward closeout panel in the right hand baggage compartment.		
3.10	Access panel Aft of landing light.		
3.11	Remove the right hand transmission cowling.		
3.12	Remove the left hand transmission cowling.		
3.13	Remove lower nose right window.		
3.14	Remove the front belly cowling.		
3.15	Remove the center belly cowling.		
3.15a	Remove the right middle belly cowling.		
3.15b	Lower the rear belly cowling.		

Aircraft Preparation

STEP	PROCEDURE	MECH	INSP
3.16	Remove the cargo net from the rear baggage compartment. (If installed)		
3.17	Remove the rear cargo compartment floor.		
3.18	Remove the electrical compartment cover. NOTE: Determine location for air conditioning power hook up. Reinstall cover to prevent FOD.		
3.19	Remove the rear cargo compartment forward floor panel.		
<p><u>NOTE:</u></p> <p>After installation of system, a thorough inspection of all areas affected must be performed to determine security component installations and workman-ship standards prior to reassembly of aircraft and return to service by a qualified individual.</p>			

Step 4

Removal of Factory Installed Components

Removal of Factory Installed Components

STEP	PROCEDURE	MECH	INSP
4.1	Unbolt oil cooling fan and shroud tiwrap to transmission.		
4.2	Disconnect oil cooler assembly from aft cabin wall and the wrap to transmission. Do not disconnect oil lines.		
4.3	Remove fresh air duct between oil cooler and discard.		
4.4	Remove aft right side seat mount bracket for installation of doubler. Ref 5-21-AS350		
4.5	(Intentionally left Blank)		
4.6	Remove warning horn forward of co-pilots feet. Hold for reinstallation.		
4.7	Remove NR digital indicator box forward of co-pilots feet. Hold for reinstallation.		
4.8	Remove glare shield.		
4.9	Remove T4 correction chart holder. Hold for reinstallation.		

Step 5

Installation of Aft Evaporator

Installation of Aft Evaporator

STEP	PROCEDURE	MECH	INSP
5.1	Remove Right Hand Transmission Cowling Forward latch. (See photo 1). Hold for reinstallation. Position the aft evaporator doubler P/N 260328-1 on the upper transmission deck per drawing 4-3-AS350 sheet 1 of 2. Mark around doubler and remove all existing rivets, bolts, and nut plates to allow the doubler to sit flat on deck.		
5.2	Drill through deck using pilot holes in doubler. Back drill the doubler from existing holes in the deck.		
5.3	Mark and cut openings in the transmission deck using doubler P/N 260328-1 as a template.		
5.4	Install aft evaporator doubler P/N 260328-1 on right hand upper transmission deck in accordance with drawing 4-3-AS350 sheet 1 of 2 using rivets as shown. Re-install Right Hand Transmission Cowling Forward latch as shown in drawing 4-3-AS350 sheet 1 of 2.		
5.5	Next temporarily install Aft evaporator assembly P/N 560010-“O”-5 with 4 ea. AN3-5A bolts and 4 ea. AN960-10 washers per drawing 4-13-AS350.		
5.6	Position return air doubler P/N 260322-1 against aft cabin bulk head as shown in drawing 5-21-AS350 trace outline on bulkhead. Remove doubler and drill out rivets inside trace.		
5.7	Reposition doubler P/N 260322-1. Back drill all holes and Cleo in place. Using doubler as guide pen route out return air hole.		
5.8	Remove doubler, clean holes. Install doubler P/N 260322-1 and angle P/N 260322-2 rivet in place per drawing 5-21-AS350. NOTE: Two different situations, requiring different doublers are utilized depending on the type and location of the aft seat harness reel (if installed). See drawing for specifics.		

RSG Products Inc.
INSTALLATION OF AFT EVAPORATOR – AS350 Air Conditioning



PHOTO 1

Installation of Aft Evaporator

STEP	PROCEDURE	MECH	INSP
5.9	Install return air screen P/N 080022-1 as per drawing 5-21-AS350.		
5.10	<p>Locate “Return Air Connector” P/N 250166. Trial fit to the aft side of the cabin wall, immediately in front of the aft evaporator. The open side of the connector must face aft. Slide the connector upward until it contacts the forward side of the evaporator. Mark with a pencil, the inside of the connector position on to the evaporator. Remove the connector and evaporator. Reference drawing 4-13-AS350.</p> <p>Draw a line one (1) inch above the lower/forward face of the evaporator case. Trial fit “Return Air Connector” to the evaporator, ensuring that the flanges of the connector DO NOT go past the inboard/outboard sides of the evaporator.</p> <p>Confirm the pencil lines. Remove the connector. Cut out the area within the pencil lines, leaving the one (1) inch lower lip on the evaporator case as a drain seal.</p> <p>NOTE: ENSURE DURING DRILLING THAT THE COIL INSIDE THE CASE IS NOT DAMAGED.</p> <p>Seal and secure the Return Air Duct Connector PN: 250166 with rivets to the Evaporator PN: 560010-O-5 case per drawing 4-13-AS350. Next install the connector angle assembly P/N 510261, per drawing 4-3-AS350 Sheet 1 of 2 and 4-13-AS350. This holds the upper part of the return air duct.</p>		
5.11	Position the aft evaporator return air duct P/N 250149 in the right side baggage compartment as shown on drawing 4-13-AS350. Use the return air opening to locate the return air duct. Trim the return air duct as required to fit.		
5.12	Remove the access panel from the outboard side of the aft evaporator P/N 560010-O-5.		
5.13	Temporarily install the aft evaporator, P/N 560010-O-5 using 4 each, AN3-5A, bolts and AN960-10, washers.		

Installation of Aft Evaporator

STEP	PROCEDURE	MECH	INSP
5.14	Locate and drill the holes for mounting the aft evaporator return air duct connector P/N 250166.		
5.15	Attach Return Air Duct P/N 250149 per drawings 4-3- AS350 sheet 1 of 2 and 4-13-AS350.		
5.16	<u>SEAL THE EVAPORATOR TO THE RETURN AIR DUCT WITH ALUMINUM FOIL TAPE</u> PN: 070076 as required by reaching through the outboard opening in the evaporator. Re-install the aft evaporator access panel.		
5.17	Install the Aft Evaporator Fan Assembly, P/N 490017-1-02, using five each AN3-5A bolts, and 5 ea. AN960-10 washers.		
5.18	Locate Transition Elbow P/N 520036-3. This will be mounted on upper Aft Cabin Wall on transmission side. See drawing 4-3-AS350 Sheets 1 and 2. Remove oil coolers from upper deck dog house. (Do Not Disconnect oil Lines) Position as to be able to modify Aft cabin wall. Do Not Re-install until step 5.22.		
5.19	Mark hole to be cut out in aft cabin wall per drawing 4-3-AS350 Sheet 1 of 2. Be careful not to but the cabin air duct bonded to aft cabin wall. Drill a couple of # 40 holes to see if you clear duct.		
5.20	Cut out hole and mount elbow as shown in drawing No. 4-3-AS350 Sheet 1 and 2 of 2.		
5.21	Install a 5-inch flex duct (25" in) long from the aft evaporator fan assembly to the aft air distribution elbow end with two each 6" band clamps P/N 060035. Insulate the duct with foam tape P/N 070078 and wrap with aluminum tape P/N 070076.		
5.22	Modify over head wemac's as shown in drawing 5-10-AS350 if S/N 1302 or lower. Remove existing spacer air duct between oil coolers. Install new Air Duct Closure Assembly PN: 510092 using existing hardware. Re-install oil cooler assembly.		
5.23	Install hose doubler P/N 260369 per drawing 3-5-AS350.		

NOTE:
 RIVET LENGTH MAYBE DETERMINED UPON INSTALLATION.
 INTERCHANGEABILITY BETWEEN MS20470AD-4-X RIVETS
 AND CR3242-4-X OR CR3243-4-X RIVETS IS APPROVED.

AFTER B3, S/N: 3322, REMOVE GROMMET IN P/N 520036-3.
 CUT OUT OPENING TO 1.6 X 7.2 OR TO MATCH DUCT OPENING AS IN VIEW C-C. ROUTE
 PUSH/PULL CABLES AND ELECTRICAL HARNESS TO LEFT AND TIE WRAP TOGETHER.

SLOT THE TRANSITION ELBOW AS REQUIRED, TYP. B3 MODELS (SEE PAGE 2 OF 2 FOR
 ALTERNATE INSTALL.) SLIDE TRANSITION ELBOW OVER CABLES AND PLACE ELBOW IN
 POSITION AGAINST AFT CABIN WALL. BACK DRILL 6 EACH MOUNTING HOLES. REMOVE AND
 SEAL FLANGE TO AFT CABIN WALL WITH P.R.C. OR EQUIVALENT. REINSTALL DUCT TO AFT
 CABIN WALL USING HARDWARE CALLED OUT.

USING STRAP, P/N 261299 SANDWICH DUCT TO AFT CABIN WALL BY USING TOP AND
 TOP/LEFT HAND MOUNTING HOLES AS SHOWN.

REINSTALL GROMMET AND COVER ENTIRE AREA WITH FOIL TAPE.

TRIM DOUBLER AS REQUIRED FOR BEST FIT AND MAINTAIN MIN. EDGE DISTANCE.

- MS20470AD-4-X (FIELD)
- ⊙ MS20470AD-4-X (REPLACES EXIST. RIVETS)
- MS20426AD-4-X (CSK. AT TOP SURFACES)
- ⊗ .228 DIA HOLE #1 DRILL (FOR AN 3-5A BOLT)
- EXISTING

AFT SIDE CABIN WALL

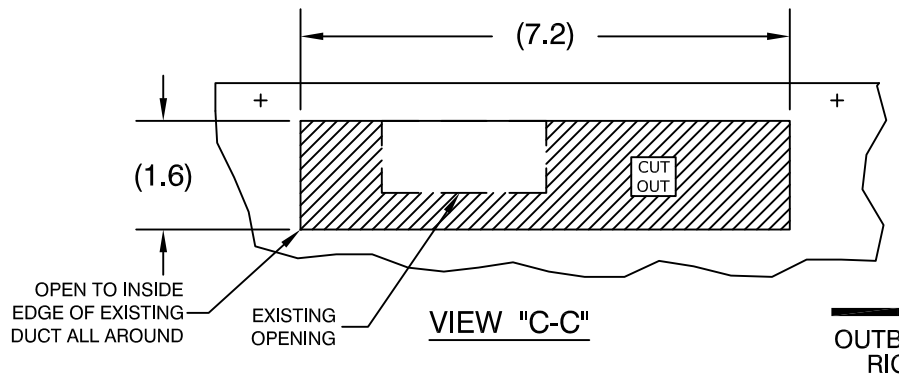

OUTBOARD RIGHT

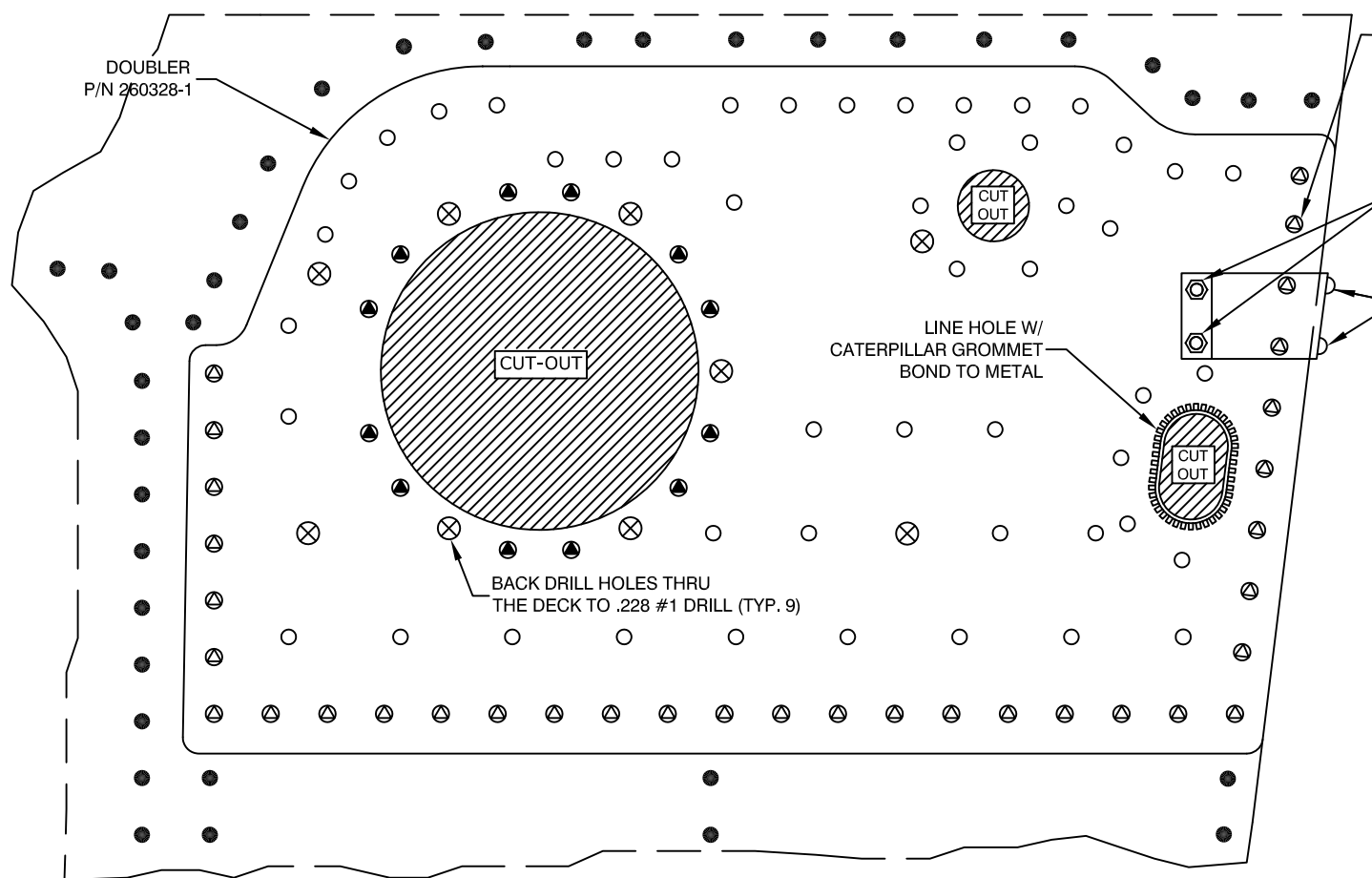

VIEW LOOKING DOWN AT TRANSMISSION DECK

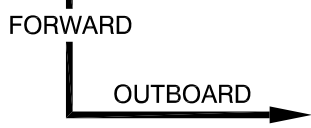

-02 AFT EVAPORATOR INSTALL WITH FAN ASSEMBLY 490017-1-02 (BRUSHLESS MOTOR) (AS NOTED)

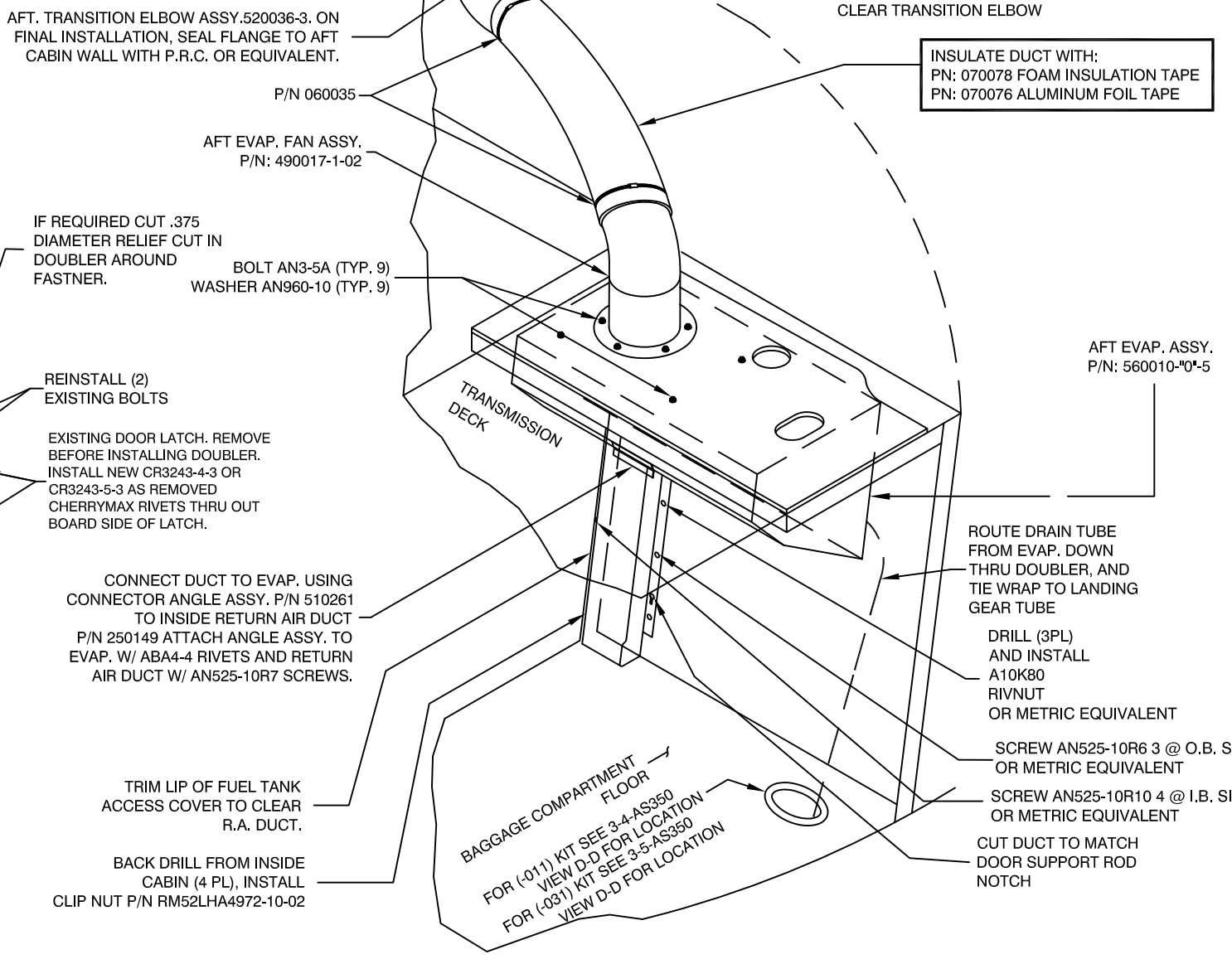

REVISION RECORD				
REV	DATE	DESCRIPTION OF CHANGE	APPVD. BY	REV. BY
D	09/1/14	CHANGED TITLE BLOCK AND REVISION BLOCK. INCORPORATED ECO 0204, 0324, 0538, 0554, & 0654.		AJC
E	01/19/22	INCORPORATED ECO'S 0845, 1004 AND 1024.		SGB
F	08/04/23	INCORPORATED ECO'S 1143, 1145, 1164, 1176, 1186 AND 1233.		SGB

SEE ECO 1281

PROPRIETARY NOTICE TO ALL PERSONS RECEIVING THIS DOCUMENT THIS DOCUMENT AND INFORMATION OR TECHNICAL DATA AND DESIGNS CONTAINED HEREIN ARE PROPRIETARY DATA AND EXCLUSIVE PROPERTY OF RSG PRODUCTS INC. AND IS DELIVERED ON THE EXPRESS CONDITION THAT NEITHER THIS DOCUMENT NOR THE INFORMATION CONTAINED HEREIN SHALL BE DISCLOSED TO OTHERS, REPRODUCED IN WHOLE OR IN PART, OR USED FOR THE MANUFACTURE OR FABRICATION OF PARTS FOR ANYONE OTHER THAN RSG PRODUCTS INC. WITHOUT WRITTEN CONSENT AND AUTHORIZATION, AND THAT NO RIGHT IS GRANTED TO DISCLOSE OR SO USE ANY INFORMATION CONTAINED IN SAD DOCUMENT. THIS RESTRICTION DOES NOT LIMIT THE RIGHT TO USE INFORMATION OBTAINED FROM ANOTHER SOURCE.	NEXT ASSY.	TOLERANCES EXCEPT AS SHOWN
	APPROVED BY:	.X: ±.1 .XX: ±.03 .XXX: ±.010 X.X": ±.5" BREAK ALL SHARP EDGES .01 ALL DIMENSIONS IN INCHES UNLESS OTHERWISE STATED

RSG PRODUCTS INC.
 A ROTORCRAFT SERVICES GROUP COMPANY

TITLE:
AFT EVAPORATOR INSTALL

DRAWN BY: JDS	DATE: 11/06/01	REV.: F	SCALE: N/A	SHEET: 1 OF 2
APPLICATION: AS350 SERIES			DWG. NO.: 4-3-AS350	

NOTES:

1. TRIM MATING SURFACES OF ELBOW FOR ALIGNMENT OF ELBOW TO CABIN DUCT.
2. POSITION ELBOW ABOVE CABLES AND ALIGN WITH CABIN DUCT.
3. TRACE CABLE ROUTING ONTO LOWER SIDE OF ELBOW.
4. CUT ELBOW TO ALLOW CABLES TO PASS THROUGH WITHOUT INTERFERENCE.
5. OPEN AFT END OF CUT TO APPROX 1" AND INSTALL GROMMET.
6. INSTALL ELBOW TO CABIN AFT WALL PER STANDARD INSTALLATION INSTRUCTIONS.
7. SEAL OPENINGS BOTH INSIDE AND OUT WITH ALUMINUM FOIL, SEAL AREA BETWEEN CABLES AND GROMMET WITH SEALING CORK PN: 070078-6 OR PROSEAL 890 TO ENSURE THAT ELBOW IS AIR TIGHT.
8. EMI FILTER KIT P/N: 050143-2. (SEE TABLE 1)

ALTERNATE PROCEEDURE FOR INSTALLING AFT TRANSITION ELBOW ASSEMBLY PN: 520036-3, AS350-B3 SERIES TO AVOID REROUTING OF ROTORBRAKE AND FUEL SELECTOR CABLES.

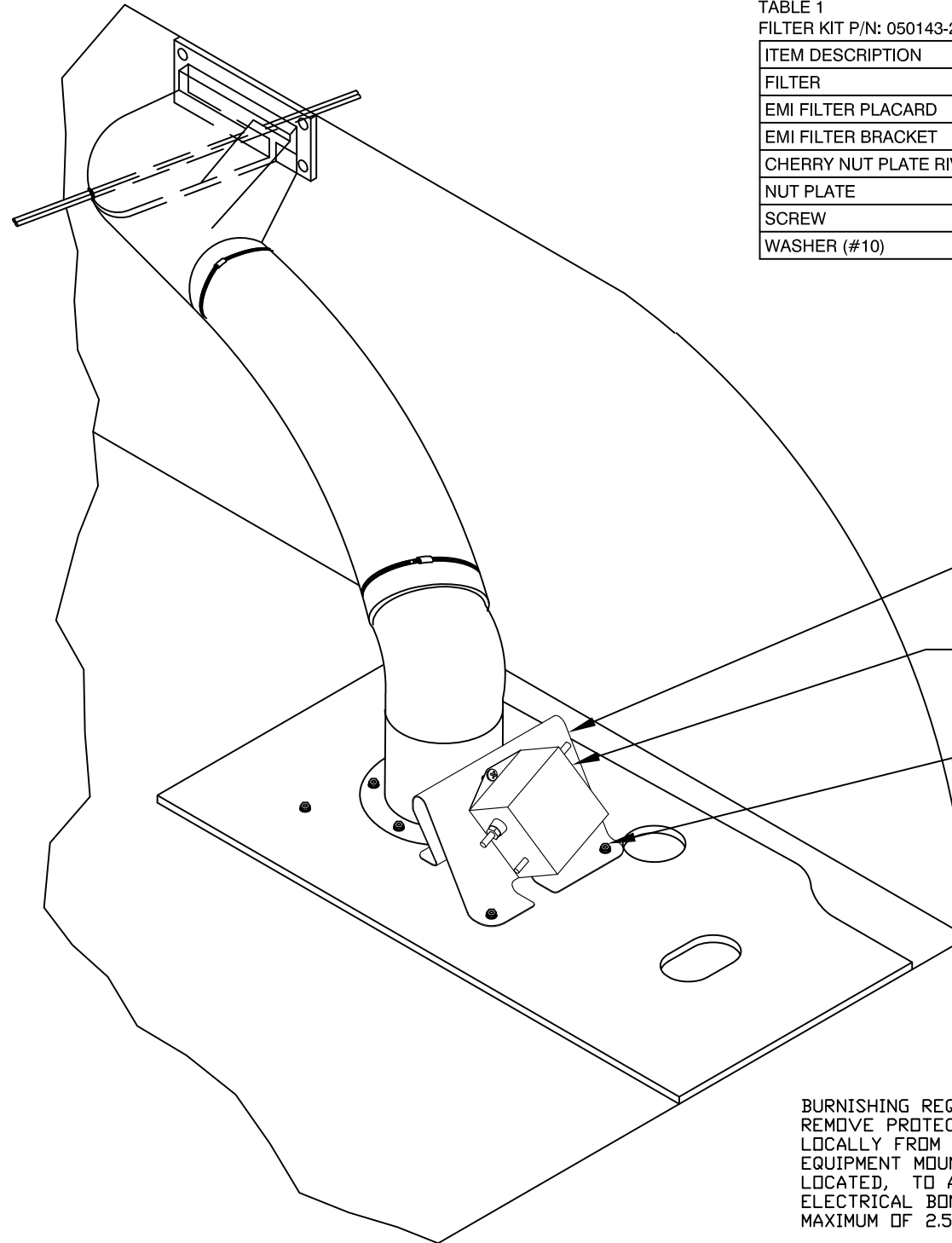
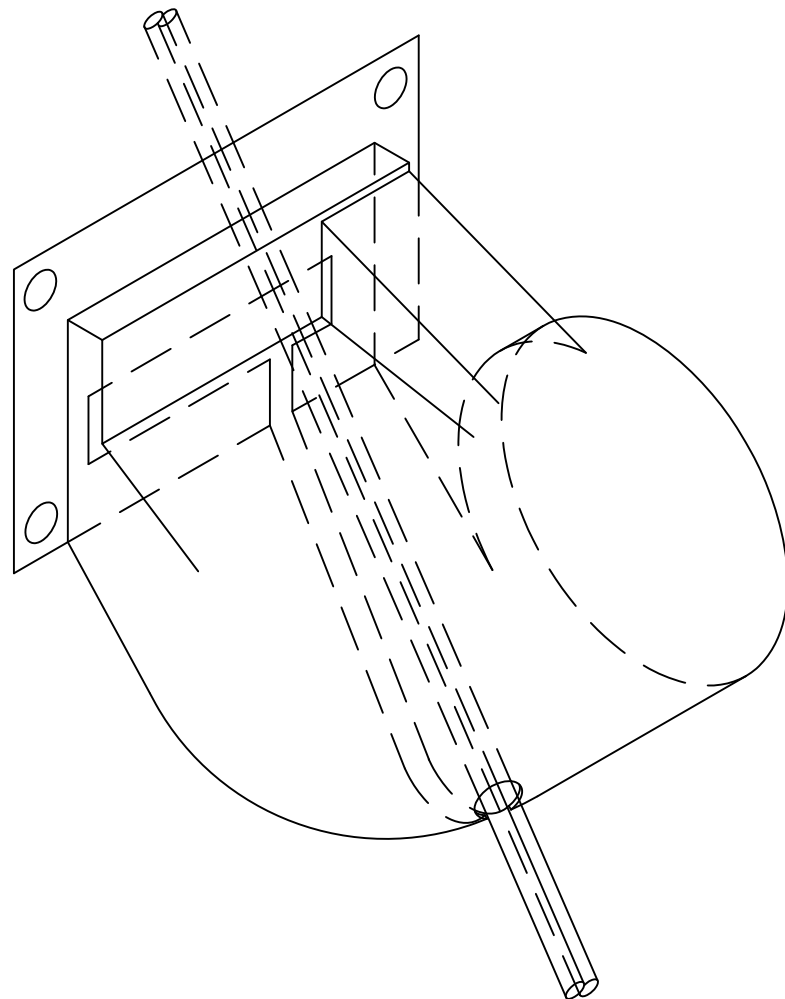



TABLE 1
FILTER KIT P/N: 050143-2

ITEM DESCRIPTION	PART NUMBER	QTY
FILTER	13619-RF16883	1
EMI FILTER PLACARD	13619-RF16883P	1
EMI FILTER BRACKET	04-350-21-108-01	1
CHERRY NUT PLATE RIVET	CCR264CS3-02	4
NUT PLATE	MS21075-3N	2
SCREW	MS27039-1-07	2
WASHER (#10)	NAS1149D0316J	2

- 04-350-21-108-01 (AFT EVAP EMI FILTER BRACKET) 1EA
- 13619-RF16883 (EMI FILTER) 1EA
- MS21075-3N (NUTPLATE) 2EA
- CCR264CS-3-02 (RIVET) 4EA
- MS27039-1-07 (SCREW) 2EA
- NAS1149D0316J (WASHER) 2EA

FOR BRACKET ATTACHMENT USE EXISTING AN3-5A BOLTS, 3 PLACES TRIM BRACKET 04-350-21-108-01 AS NECESSARY TO FIT AGAINST MOTOR AND SEAL UNDER FOOT WITH RTV 732 OR EQUIVALENT AS REQUIRED FOR FOD PREVENTION

BURNISHING REQUIREMENTS:
REMOVE PROTECTIVE FINISH LOCALLY FROM SURFACES WHERE EQUIPMENT MOUNTING HOLES ARE LOCATED, TO ASSURE A PROPER ELECTRICAL BOND MEASURING A MAXIMUM OF 2.5 MILLIOHMS.



TITLE:
AFT EVAPORATOR INSTALL

DRAWN BY: JDS	DATE: 11/06/01	REV.: F	SCALE: N/A	SHEET: 2 OF 2
APPLICATION: AS350 SERIES				DWG. NO.: 4-3-AS350



ENGINEERING
CHANGE
ORDER

ECO No. 1281	SHT 1 OF 1
DWG No. 4-3-AS350	REV F
DWG No.	REV
DWG No.	REV

REF. STC No. SH3509SW

EFFECTIVITY:
 ALL UNITS THIS CUSTOMER LIMITED UNITS SPECIFIED
 ALL UNITS MFG'D AFTER THIS DATE OTHER ALL UNITS

CHANGE CLASS:
 RECORD CHG. PARTS NOT AFFECTED NON-INTERCHANGEABLE PARTS
 INTERCHANGEABLE PARTS OTHER _____

EXISTING/IN-WORK STOCK DISPOSITION:
 RECORD CHG. PARTS NOT AFFECTED RE-WORK EXISTING STOCK
 SCRAP EXISTING STOCK OTHER BREAK IN AT NEXT BUILD

DESCRIPTION OF CHANGE: CORRECT QTY FOR AN 8 HOLE INSTALLATION. CHANGES MADE IN THE MAIN NOTES 'BACK DRILL 8 EACH MOUNTING HOLES" AND FOV NOTES IN SECTION D3 CHANGE QTY FROM 6 TO 8 (2 TIMES) AND QTY 12 TO 16.

WAS:

NOTE:

RIVET LENGTH MAYBE DETERMINED UPON INSTALLATION.
 INTERCHANGEABILITY BETWEEN MS20470AD-4-X RIVETS
 AND CR3242-4-X RIVETS IS APPROVED.

AFTER B3, S/N: 3322, REMOVE GROMMET IN P/N 520036-3.
 CUT OUT OPENING TO 1.6 X 7.2 OR TO MATCH DUCT OPENING AS IN VIEW C-C. ROUTE
 PUSH/PULL CABLES AND ELECTRICAL HARNESS TO LEFT AND TIE WRAP TOGETHER.

SLOT THE TRANSITION ELBOW AS REQUIRED, TYP. B3 MODELS (SEE PAGE 2 OF 2 FOR
 ALTERNATE INSTALL.) SLIDE TRANSITION ELBOW OVER CABLES AND PLACE ELBOW IN
 POSITION AGAINST AFT CABIN WALL. BACK DRILL 6 EACH MOUNTING HOLES. REMOVE AND
 SEAL FLANGE TO AFT CABIN WALL WITH P.R.C. OR EQUIVALENT. REINSTALL DUCT TO AFT
 CABIN WALL USING HARDWARE CALLED OUT.

USING STRAP, P/N 261299 SANDWITCH DUCT TO AFT CABIN WALL BY USING TOP AND
 TOP/LEFT HAND MOUNTING HOLES AS SHOWN.

REINSTALL GROMMET AND COVER ENTIRE AERA WITH FOIL TAPE.

REMOVE EXISTING AIRBUS BRACKET P/N 350A72483702 AND STIFFENER P/N 350A21104136
 AS NECESSARY.

AN3-6A (BOLTS) 6 EA.
 MS21044-N3 (NUT) 6 EA.
 AN960-10 (WASHERS) 12 EA.

IS:

NOTE:

RIVET LENGTH MAYBE DETERMINED UPON INSTALLATION.
 INTERCHANGEABILITY BETWEEN MS20470AD-4-X RIVETS
 AND CR3242-4-X RIVETS IS APPROVED.

AFTER B3, S/N: 3322, REMOVE GROMMET IN P/N 520036-3.
 CUT OUT OPENING TO 1.6 X 7.2 OR TO MATCH DUCT OPENING AS IN VIEW C-C. ROUTE
 PUSH/PULL CABLES AND ELECTRICAL HARNESS TO LEFT AND TIE WRAP TOGETHER.

SLOT THE TRANSITION ELBOW AS REQUIRED, TYP. B3 MODELS (SEE PAGE 2 OF 2 FOR
 ALTERNATE INSTALL.) SLIDE TRANSITION ELBOW OVER CABLES AND PLACE ELBOW IN
 POSITION AGAINST AFT CABIN WALL. BACK DRILL 8 EACH MOUNTING HOLES. REMOVE AND
 SEAL FLANGE TO AFT CABIN WALL WITH P.R.C. OR EQUIVALENT. REINSTALL DUCT TO AFT
 CABIN WALL USING HARDWARE CALLED OUT.

USING STRAP, P/N 261299 SANDWITCH DUCT TO AFT CABIN WALL BY USING TOP AND
 TOP/LEFT HAND MOUNTING HOLES AS SHOWN.

REINSTALL GROMMET AND COVER ENTIRE AERA WITH FOIL TAPE.

REMOVE EXISTING AIRBUS BRACKET P/N 350A72483702 AND STIFFENER P/N 350A21104136
 AS NECESSARY.

AN3-6A (BOLTS) 8 EA.
 MS21044-N3 (NUT) 8 EA.
 AN960-10 (WASHERS) 16 EA.

REMARKS: MINOR CHANGE.
 CHANGE QTY IN MULTIPLE LOCATIONS.

ENGINEERING REVIEW BOARD		
SIGNATURE	STAMP	DATE
	MRB04	1/22/2024
	QA22	1/23/2024
	P016	1/23/2024
INCORPORATION STATUS		
<input type="checkbox"/> IMMEDIATE <input checked="" type="checkbox"/> OUTSTANDING		

INSTALLATION INSTRUCTIONS:

1. AFT EVAPORATOR AND RETURN AIR DUCT INSTALLATION:
 2. TEMPORARILY INSTALL EVAPORATOR ASSEMBLY, P/N 560010-0-5 UNDER NEWLY INSTALLED DOUBLER WITH 4X AN3-5A BOLTS AND 4X AN960-10 WASHERS AS SHOWN.
 3. LOCATE "RETURN AIR CONNECTOR" P/N 250166. TRIAL FIT TO THE AFT SIDE OF THE CABIN WALL, IMMEDIATELY IN FRONT OF THE AFT EVAPORATOR. THE OPEN SIDE OF THE CONNECTOR MUST FACE AFT. SLIDE THE CONNECTOR UPWARD UNTIL IT CONTACTS THE FORWARD SIDE OF THE EVAPORATOR. MARK WITH A PENCIL, THE INSIDE OF THE CONNECTORS POSITION ON TO THE EVAPORATOR. REMOVE THE CONNECTOR AND EVAPORATOR. NOTE: THIS HOLE MAY ALREADY EXIST IF IFS HAS TEST RUN SYSTEM AT ITS LOCATION.
 4. LOCATE A LINE ONE (1) INCH ABOVE THE LOWER/FORWARD FACE OF THE EVAPORATOR. TRIAL FIT CONNECTOR TO THE EVAPORATOR, ENSURING THAT THE FLANGES OF THE CONNECTOR DO NOT GO PAST THE INBOARD/OUTBOARD SIDES OF THE EVAPORATOR.
 5. CONFIRM THE PENCIL LINES. REMOVE THE CONNECTOR. CUT OUT THE AREA WITHIN THE PENCIL LINES, LEAVING THE ONE (1) INCH LOWER LIP ON THE EVAPORATOR AS A DRAIN SEAL. SEAL AND SECURE WITH RIVETS, THE CONNECTOR TO THE EVAPORATOR PER THE DRAWING.
 6. TRIAL FIT RETURN AIR DUCT P/N 250149. BACK DRILL FROM INSIDE THE CABIN AT FOUR PLACES, EQUALLY SPACED, AT INBOARD EDGE OF RETURN AIR DUCT FLANGE. DRILL THREE PLACES, EQUALLY SPACED, ON OUTBOARD EDGE OF RETURN AIR DUCT FLANGE, THROUGH FLANGE INTO AIRCRAFT BOX SECTION.
 7. REMOVE DUCT AND INSTALL THREE EACH A10K80 RIVNUTS UNDER OUTBOARD FLANGE LOCATION, INTO AIRCRAFT BOX SECTION. INSTALL FOUR EACH CLIPNUTS, P/N RM52LHA4972-10-02, (ALT. PN: SL215-3-1 OR 130062), ONTO INBOARD FLANGE OF RETURN AIR DUCT. INSTALL RETURN AIR DUCT WITH SEVEN EACH AN525-10R10 SCREWS (FOUR FROM INSIDE CABIN FOR CLIPNUTS), USING K501 TAPE UNDER BOTH DUCT FLANGES AS SEALANT.
 8. CONNECT RETURN AIR DUCT TO AFT EVAPORATOR USING ANGLE, RETURN AIR CONNECTOR ASSEMBLY, P/N 510261. USE POP RIVETS, NUTPLATES AND SCREWS. SEAL ANGLE TO RETURN AIR DUCT AND AFT EVAPORATOR HOUSING.
 9. INSTALL DRAIN LINE AND ROUTE AS SHOWN IN DRAWING 4-3-AS350 SHEET 1 OF 2. SECURE DRAIN LINE WITH ADEL CLAMPS OR TIE WRAPS AND ROUTE TO A LOCATION OUTBOARD OF THE BELLY PANEL. TIE WRAP TO LANDING GEAR CROSS MEMBER ON AFT SIDE.
- INSULATE EXPANSION VALVE WITH CORK TAPE.**

NOTES:

ENSURE THAT DRAIN LINE IS NOT CRIMPED WHEN BELLY PANEL IS RE-INSTALLED.

CAUTION:

BE SURE THAT THE DRAIN LINE IS PROPERLY SECURED AND LONG ENOUGH SO THAT CONDENSATION DOES NOT FLOW FROM THE LINE, AFT INTO THE BAGGAGE COMPARTMENT.

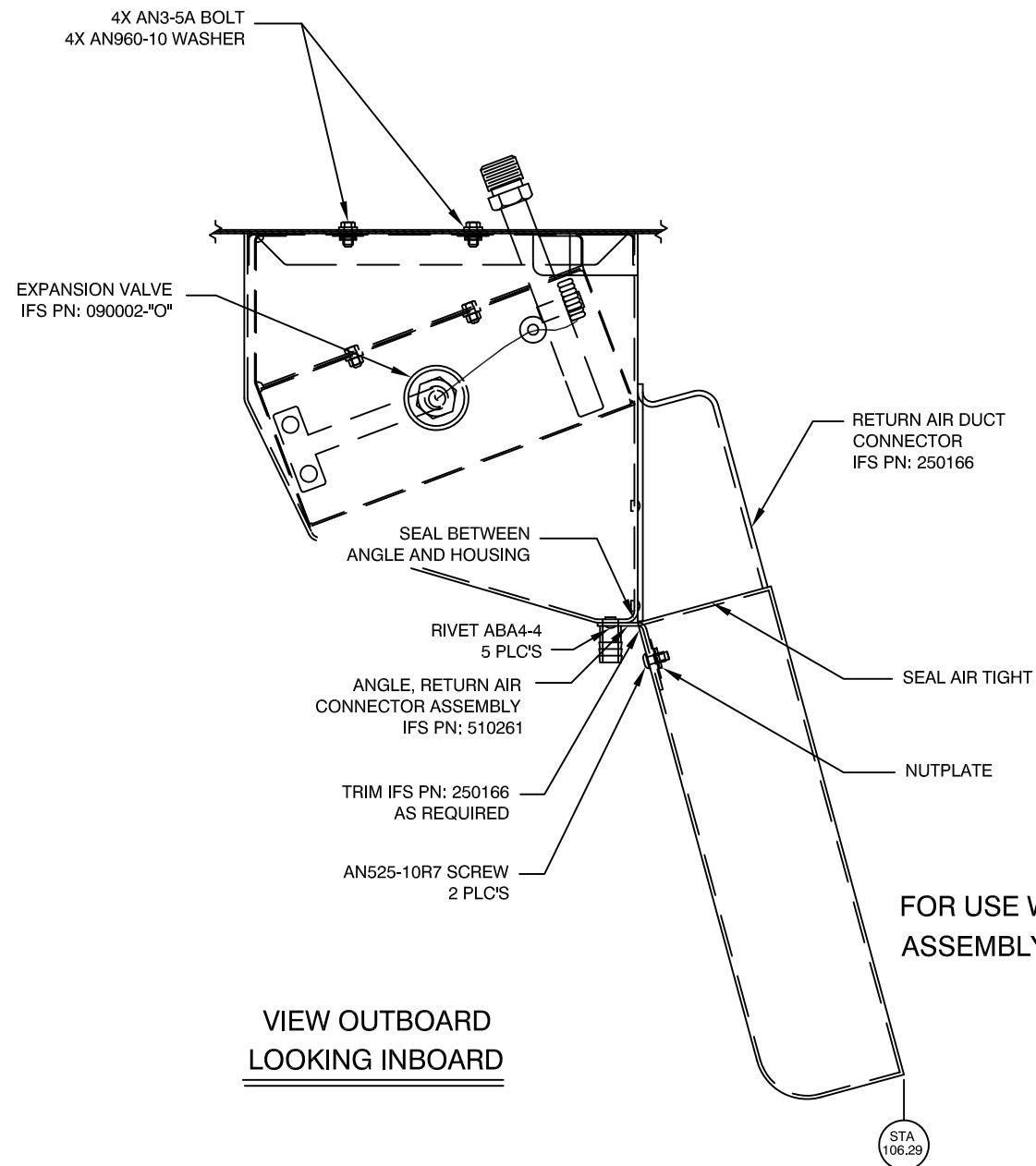

**VIEW OUTBOARD
LOOKING INBOARD**

SEE ECO 1272

NOTE: ENSURE THAT DRILLING DOES NOT HIT COIL

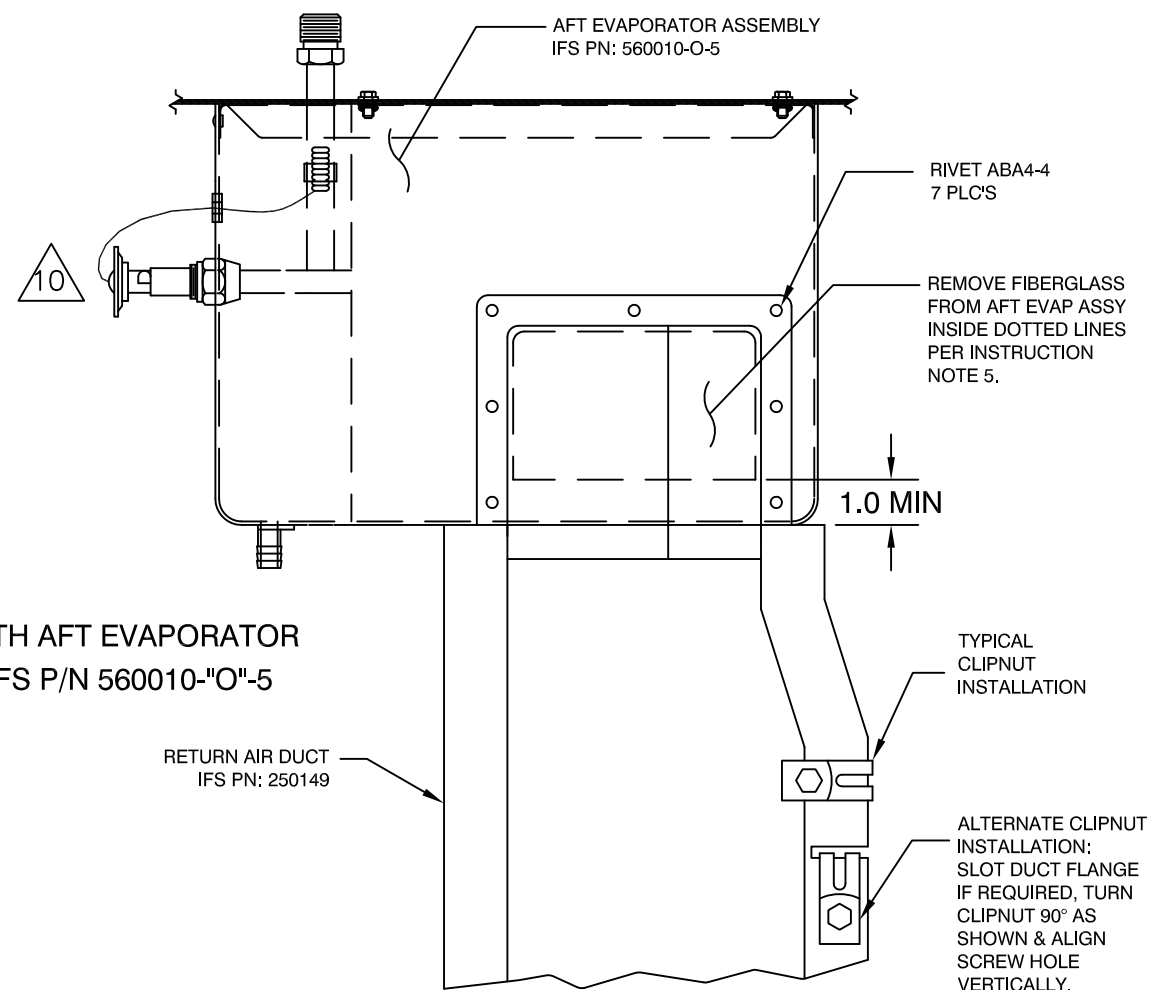

VIEW LOOKING AFT

FOR USE WITH AFT EVAPORATOR ASSEMBLY IFS P/N 560010-'O'-5

REVISION RECORD				
REV	DATE	DESCRIPTION OF CHANGE	APPVD. BY	REV. BY
A	11/07/01	CONVERTED TO AUTOCAD		
B	01/03/07	CORRECTED SENSING BULB POSITION TO MATCH MFG DWGS. REMOVED NOTES CONCERNING SENSING BULB ATTACHMENT. IT IS NOW INSTALLED AT THE ASSEMBLY STAGE, ADDED ALT. CLIPNUT P/Ns SL215-3-1 OR 130062, CHANGED FONT, ADDED DETAILS TO VIEWS TO SHOW INSTALLED. REVISED TITLE BLOCK.		JTYE
C	9/1/14	CHANGED TITLE BLOCK AND REVISION BLOCK.		AJC
D	08/04/23	INCORPORATED ECO 1182.		SGB

<p>PROPRIETARY NOTICE</p> <p>TO ALL PERSONS RECEIVING THIS DOCUMENT THIS DOCUMENT AND INFORMATION OR TECHNICAL DATA AND DESIGNS CONTAINED HEREIN ARE PROPRIETARY DATA AND EXCLUSIVE PROPERTY OF RSG PRODUCTS INC. AND IS DELIVERED ON THE EXPRESS CONDITION THAT NEITHER THIS DOCUMENT NOR THE INFORMATION CONTAINED HEREIN SHALL BE DISCLOSED TO OTHERS, REPRODUCED IN WHOLE OR IN PART, OR USED FOR THE MANUFACTURE OR FABRICATION OF PARTS FOR ANYONE OTHER THAN RSG PRODUCTS INC. WITHOUT WRITTEN CONSENT AND AUTHORIZATION, AND THAT NO RIGHT IS GRANTED TO DISCLOSE OR SO USE ANY INFORMATION CONTAINED IN SAD DOCUMENT. THIS RESTRICTION DOES NOT LIMIT THE RIGHT TO USE INFORMATION OBTAINED FROM ANOTHER SOURCE.</p>	NEXT ASSY.	TOLERANCES EXCEPT AS SHOWN			
		.X: ±.1 .XX: ±.03 .XXX: ±.010 X.X": ±.5° BREAK ALL SHARP EDGES .01 ALL DIMENSIONS IN INCHES UNLESS OTHERWISE STATED			TITLE: AFT EVAPORATOR INSTALL
	APPROVED BY:	DATE:	DRAWN BY: TMUZZY	DATE: 11/07/01	REV.: D
			SCALE: N/A	SHEET: 1 OF 1	DWG. NO.: 4-13-AS350



ENGINEERING
CHANGE
ORDER

ECO No. 1272	SHT 1 OF 1
DWG No. 4-13-AS350	REV D
DWG No.	REV
DWG No.	REV
REF. STC No. SH3509SW	

CHANGE CLASS:
 RECORD CHG. PARTS NOT AFFECTED NON-INTERCHANGEABLE PARTS
 INTERCHANGEABLE PARTS OTHER _____

EXISTING/IN-WORK STOCK DISPOSITION:
 RECORD CHG. PARTS NOT AFFECTED RE-WORK EXISTING STOCK
 SCRAP EXISTING STOCK OTHER BREAK IN AT NEXT BUILD

EFFECTIVITY:
 ALL UNITS THIS CUSTOMER LIMITED UNITS SPECIFIED
 ALL UNITS MFG'D AFTER THIS DATE OTHER ALL UNITS

DESCRIPTION OF CHANGE: UPDATE DEPICTION OF DRAIN NIPPLE. ONLY SHOWING WHAT CHANGED FOR CLARITY.

WAS:

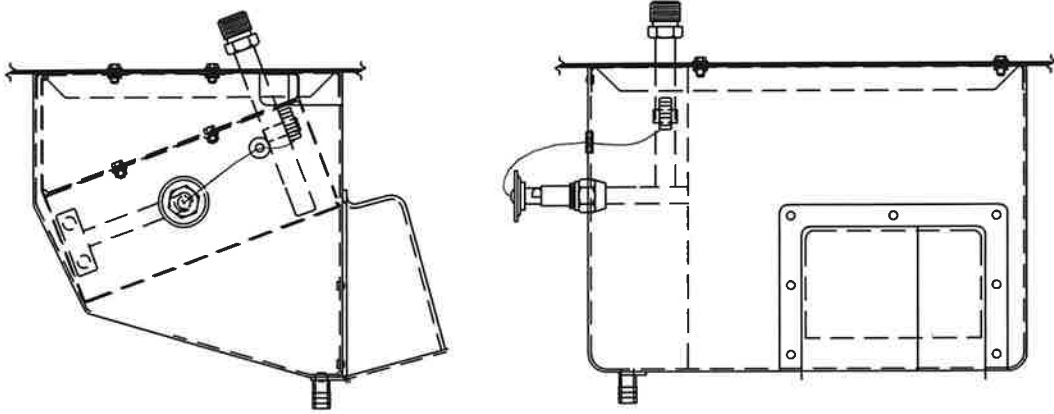

IS:

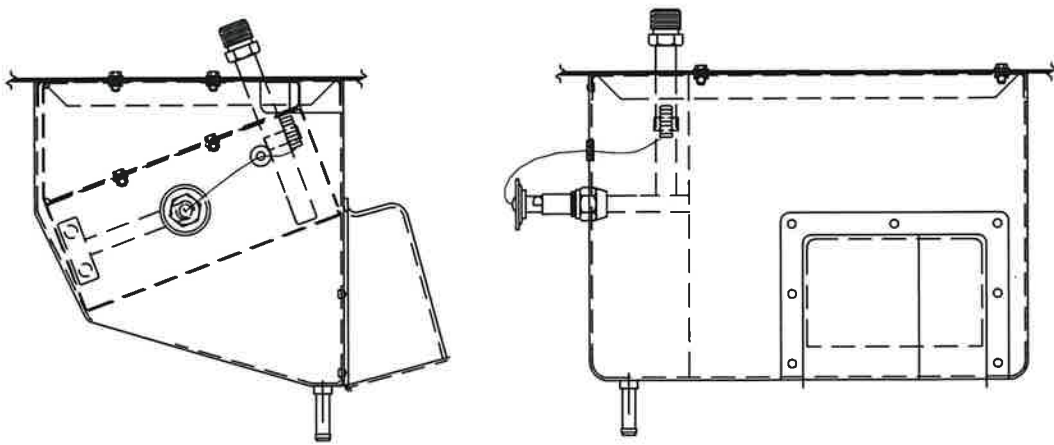

REMARKS: MINOR CHANGE. UPDATED VIEW.

ENGINEERING REVIEW BOARD		
SIGNATURE	STAMP	DATE
	MRB04	12/6/2023
	P016	12/6/2023
	P016	12/11/2023
INCORPORATION STATUS		
<input type="checkbox"/> IMMEDIATE <input checked="" type="checkbox"/> OUTSTANDING		

REVISION RECORD				
REV	DATE	DESCRIPTION OF CHANGE	APPVD. BY	REV. BY
F	9/1/14	CHANGED TITLE BLOCK AND REVISION BLOCK, ADDED -02 VIEWS AND INSTRUCTIONS PER ECO # 0709.		AJC
G	01/19/22	ADDED NOTE TO TOP DETAIL VIEW C. REMOVED BOTTOM DETAIL C VIEW. MODIFY NOTE TO VIEW LOCATED IN ZN B1. CHANGED SCREW SIZE ON NOTE IN VIEW B-B PER ECO's 0817 & 0980.		SGB
H	08/04/23	INCORPORATED ECO 1177.		SGB

DETAIL D
ACCEPTABLE TO ELONGATE OPENING TO CENTER PEDESTAL UP TO 1" FOR PROPER FITTING OF FWD EVAP DUCT.

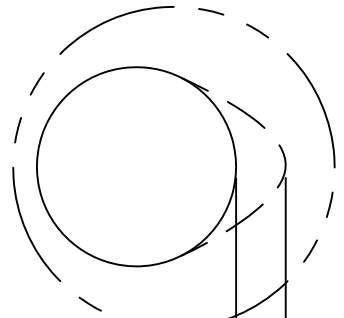

AIR DUCT CLOSURE ASSY PN 510092
REMOVE & DISCARD EXISTING FRESH AIR INLET INSTALL CLOSURE ASSY USING EXISTING HARDWARE

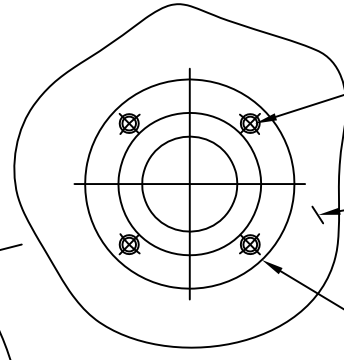
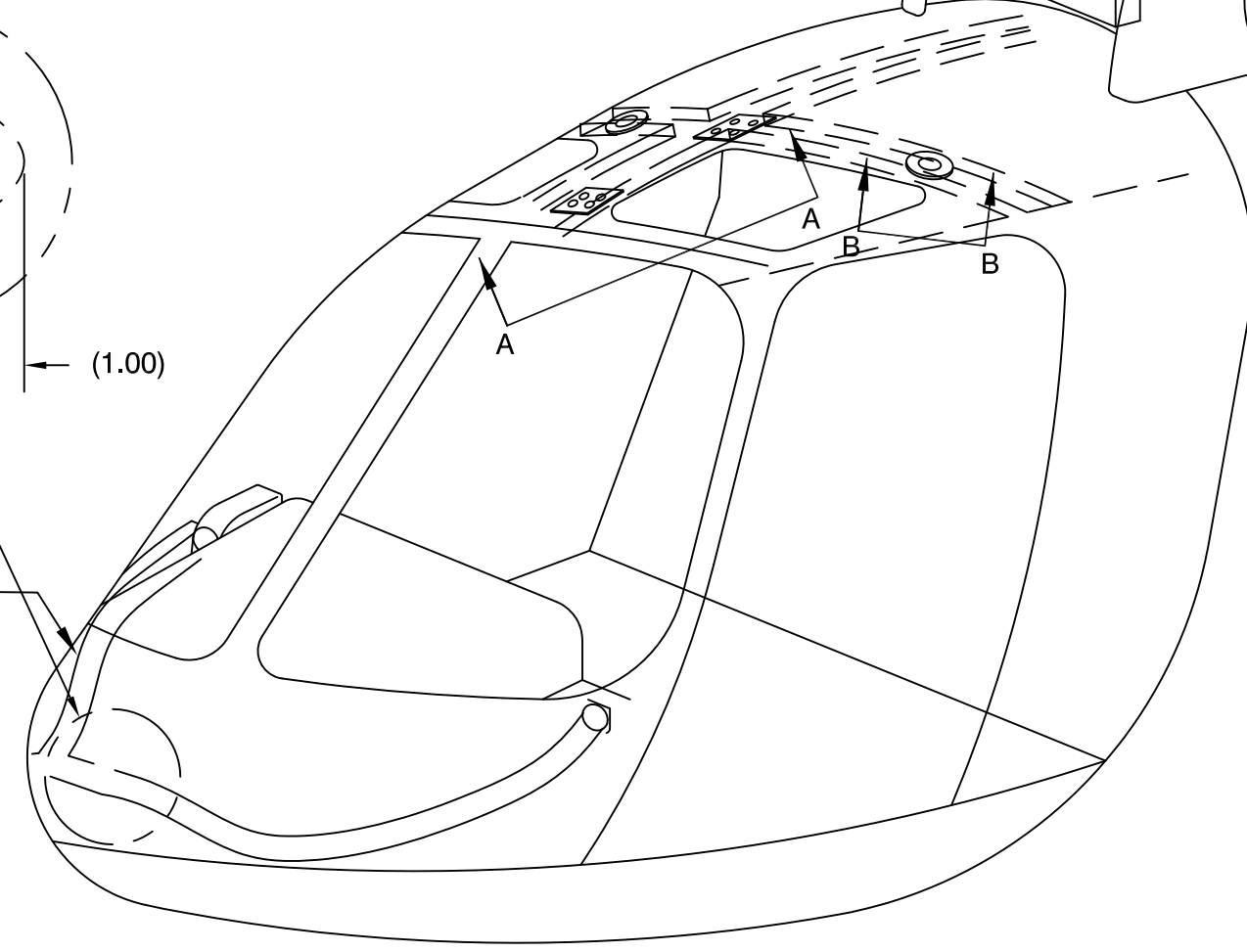

VIEW B-B

TAP EXISTING AIR OUTLET MOUNTS TO 8-32 UNF
INSTALL WEMAC USING SCREWS MS 24693-S53 (4)
SNAP ON DECOR RING NO 7194-1

TRIM HEADLINER AND CABIN STRUCTURE TO FIT WEMAC

ROTATE NEW WEMAC 90°
MATCH DRILL NEW HOLES (COUNTERSINK)
IN WEMAC TO MATCH AIR FRAME

WEMAC NO 2368-503 (CLEAR)
NOTE: APPLIES TO AIRCRAFT W/SMALL ADH AIR OUTLETS

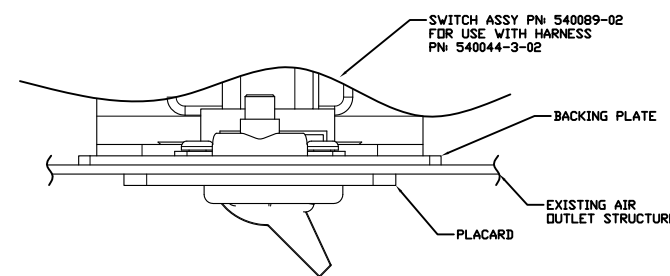

VIEW X-X

REMOVE SWITCH FROM REAR OF SWITCH ASSEMBLY PRIOR TO INSTALL. MATCH DRILL SWITCH CUTOUT AND SCREW HOLES. TRIM AS REQUIRED.

540089-02

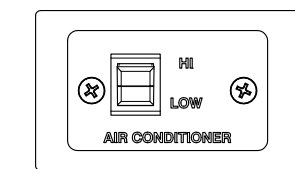

540089-02

LOCATE SWITCH ASSY AFT & LEFT OR RIGHT OF EXISTING AIR OUTLETS FOR 1995 MODELS & ON

PROPRIETARY NOTICE TO ALL PERSONS RECEIVING THIS DOCUMENT THIS DOCUMENT AND INFORMATION OR TECHNICAL DATA AND DESIGNS CONTAINED HEREIN ARE PROPRIETARY DATA AND EXCLUSIVE PROPERTY OF RSG PRODUCTS INC. AND IS DELIVERED ON THE EXPRESS CONDITION THAT NEITHER THIS DOCUMENT NOR THE INFORMATION CONTAINED HEREIN SHALL BE DISCLOSED TO OTHERS, REPRODUCED IN WHOLE OR IN PART, OR USED FOR THE MANUFACTURE OR FABRICATION OF PARTS FOR ANYONE OTHER THAN RSG PRODUCTS INC. WITHOUT WRITTEN CONSENT AND AUTHORIZATION, AND THAT NO RIGHT IS GRANTED TO DISCLOSE OR SO USE ANY INFORMATION CONTAINED IN SAID DOCUMENT. THIS RESTRICTION DOES NOT LIMIT THE RIGHT TO USE INFORMATION OBTAINED FROM ANOTHER SOURCE.	NEXT ASSY.	TOLERANCES EXCEPT AS SHOWN
	APPROVED BY:	.X: ±.1 .XX: ±.03 .XXX: ±.010 X.X": ±.5° BREAK ALL SHARP EDGES .01 ALL DIMENSIONS IN INCHES UNLESS OTHERWISE STATED



TITLE: AIR CONDITIONING OVERVIEW				
DRAWN BY: JM	DATE: 06/20/85	REV.: H	SCALE: N/A	SHEET: 1 OF 1
APPLICATION: AS350			DWG. NO.: 5-10-AS350	

REVISION RECORD				
REV	DATE	DESCRIPTION OF CHANGE	APPVD. BY	REV. BY
F	01/03/07	CORRECTED PN'S, ADDED PHOTO AND TRIMMING NOTATION. REVISED TITLE BLOCK.		JTYE
G	9/1/14	CHANGED TITLE BLOCK AND REVISION BLOCK.		AJC
H	08/04/23	INCORPORATED ECO'S 1078 AND 1116.		SGB

NOTE:
 STEPS #1 & #2 PERTAIN TO BOTH DOUBLER INSTALLATIONS
 INTERCHANGEABILITY BETWEEN MS20470 AD RIVETS & CR 3243 RIVETS ALLOWABLE, DIA AND LENGTH MAY BE DETERMINED BY THE INSTALLER

RIVET LEGEND	
○	-MS20470 AD4(IN NEW HOLE)
⊗	-CR 3243-4(IN NEW HOLE)
⊙	-CR 3243-4(IN EXISTING HOLE)
●	-MS20426AD4-X(FLUSH RIVET)

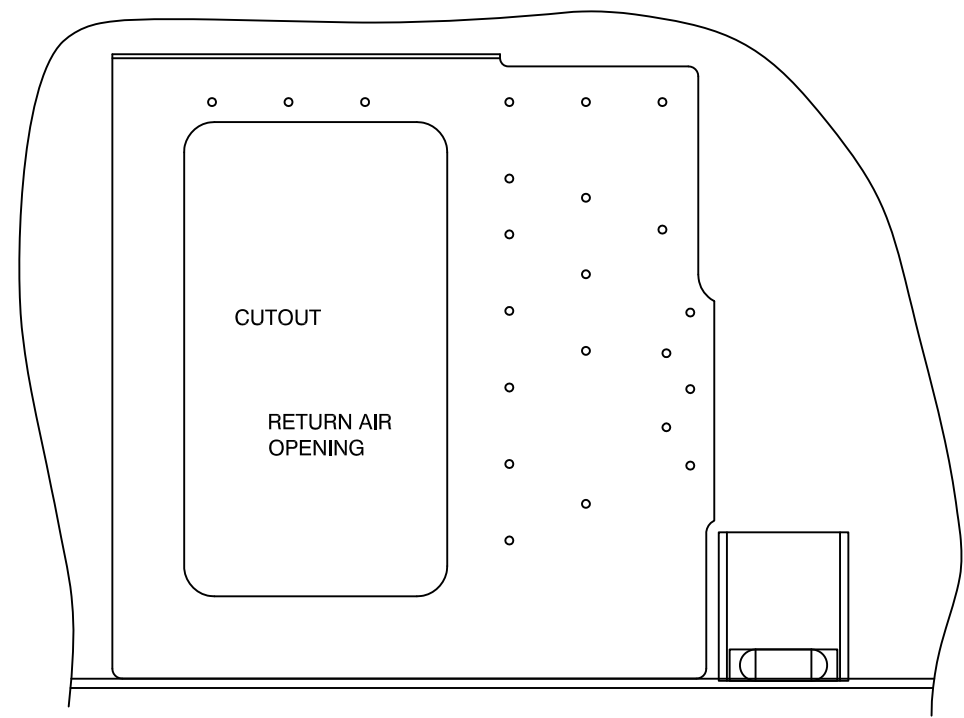

STEP 2
 MATCH DRILL DOUBLER TO AIRFRAME & AIRFRAME TO DOUBLER RIVET IN PLACE

STEP 3
 NOTE: ADD SCREEN SCREWS & SEAL EDGES

STEP 1
 NOTE: CUT OPENING IN INTERIOR AFT BULKHEAD PANEL TO MATCH RETURN AIR DOUBLER

←
 OUTBOARD, RIGHT

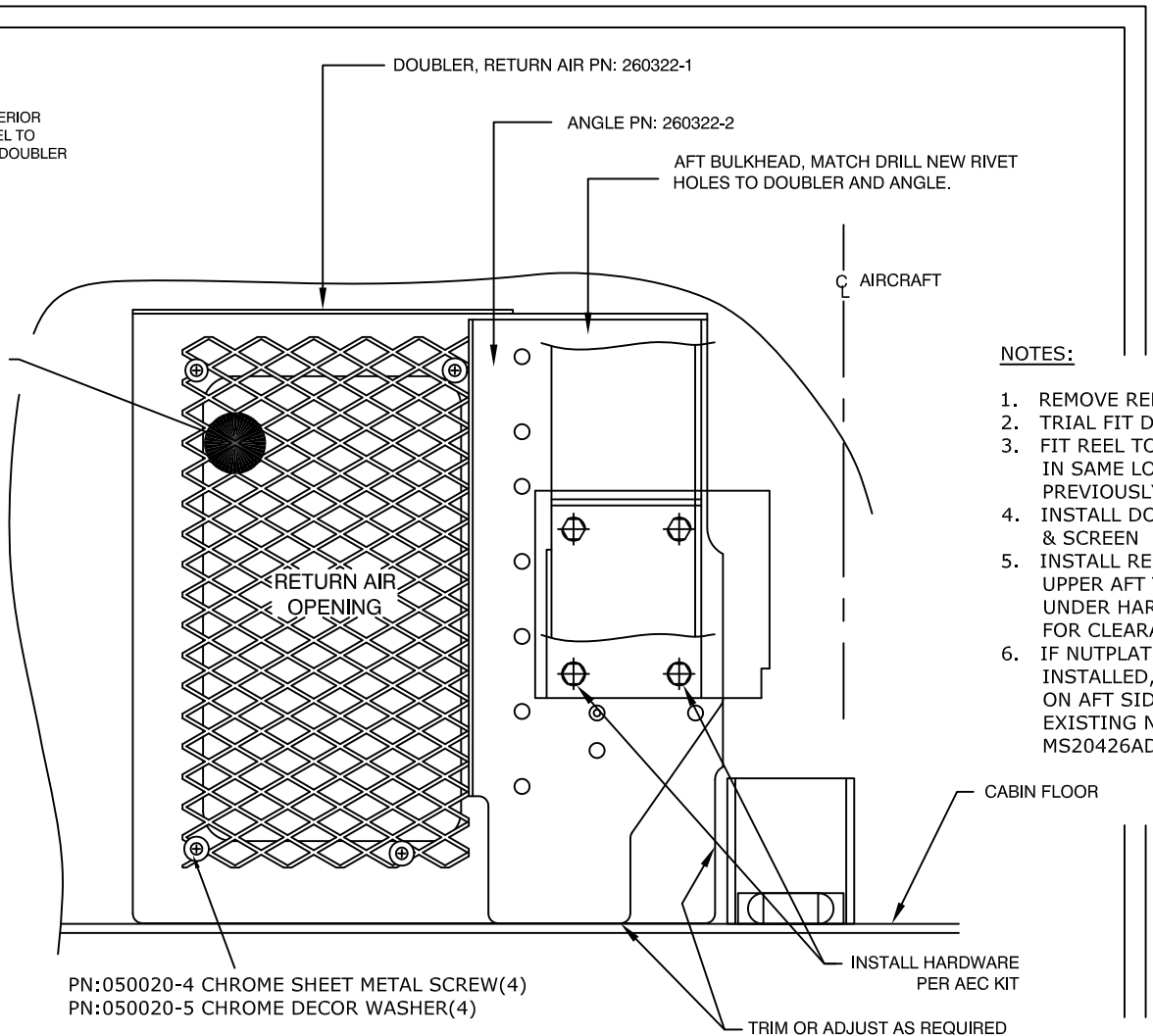

- NOTES:
1. REMOVE REEL
 2. TRIAL FIT DOUBLER ASSY
 3. FIT REEL TO DOUBLER ASSY IN SAME LOCATION AS PREVIOUSLY MOUNTED
 4. INSTALL DOUBLER ASSY & SCREEN
 5. INSTALL REEL, TRIMMING UPPER AFT TURNED LIP OF DOUBLER UNDER HARNESS, AS NECESSARY, FOR CLEARANCE
 6. IF NUTPLATES(TYP 4)ARE NOT INSTALLED, ADD PN MS21059-L3 ON AFT SIDE OF WALL, OR REINSTALL EXISTING NUT PLATES USING MS20426AD3-X OR CCR2645S3-X.

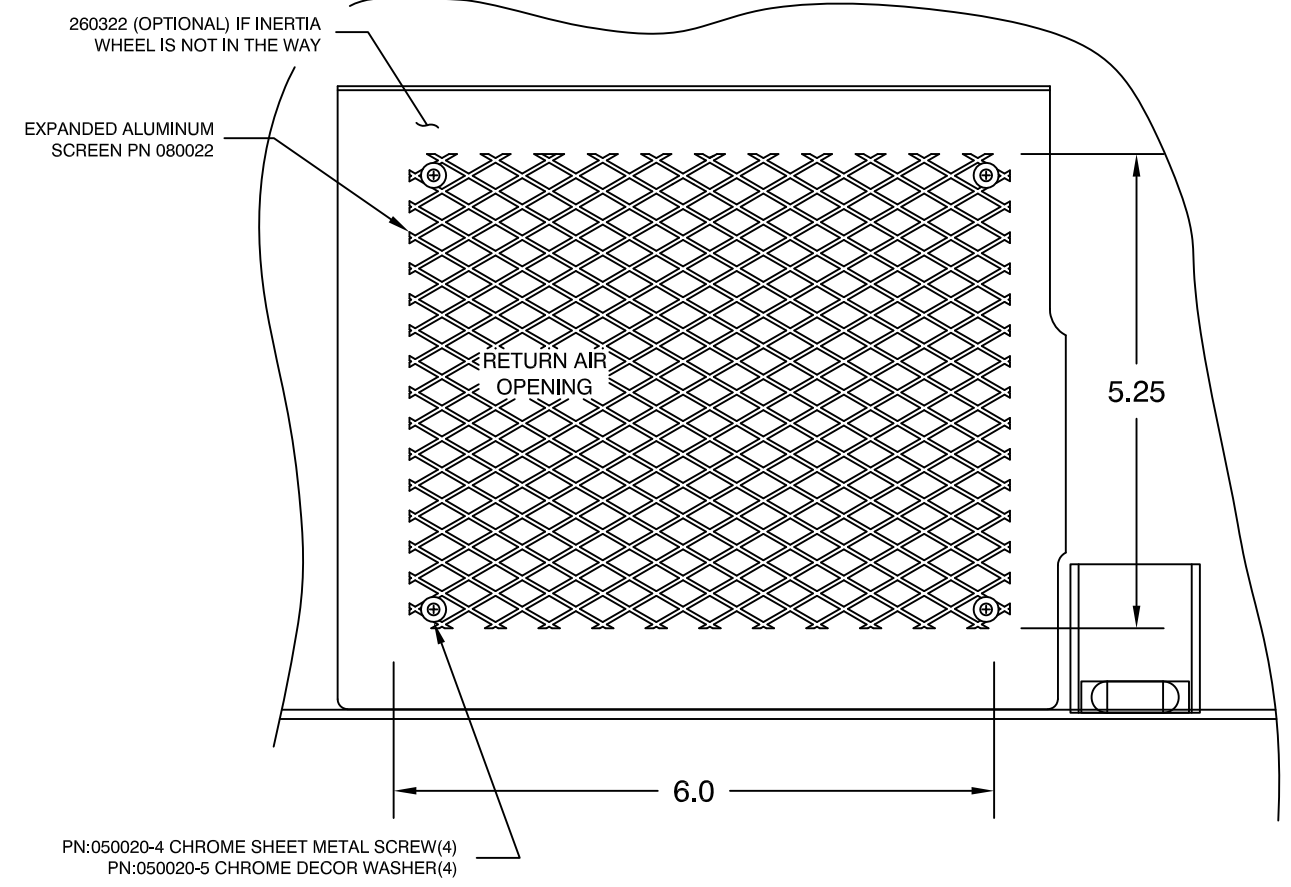

AFT CABIN BULKHEAD
 VIEW LOOKING AFT AT STA 106.29

PROPRIETARY NOTICE TO ALL PERSONS RECEIVING THIS DOCUMENT THIS DOCUMENT AND INFORMATION OR TECHNICAL DATA AND DESIGNS CONTAINED HEREIN ARE PROPRIETARY DATA AND EXCLUSIVE PROPERTY OF RSG PRODUCTS INC. AND IS DELIVERED ON THE EXPRESS CONDITION THAT NEITHER THIS DOCUMENT NOR THE INFORMATION CONTAINED HEREIN SHALL BE DISCLOSED TO OTHERS, REPRODUCED IN WHOLE OR IN PART, OR USED FOR THE MANUFACTURE OR FABRICATION OF PARTS FOR ANYONE OTHER THAN RSG PRODUCTS INC. WITHOUT WRITTEN CONSENT AND AUTHORIZATION, AND THAT NO RIGHT IS GRANTED TO DISCLOSE OR SO USE ANY INFORMATION CONTAINED IN SAD DOCUMENT. THIS RESTRICTION DOES NOT LIMIT THE RIGHT TO USE INFORMATION OBTAINED FROM ANOTHER SOURCE.	NEXT ASSY.	TOLERANCES EXCEPT AS SHOWN .X: ±.1 .XX: ±.03 .XXX: ±.010 X.X": ±.5" BREAK ALL SHARP EDGES .01 ALL DIMENSIONS IN INCHES UNLESS OTHERWISE STATED		
	APPROVED BY:	DATE:		TITLE: AIR DISTRIBUTION
	DRAWN BY: BP	DATE: 04/12/85		REV.: H
APPLICATION: AS350			DWG. NO.: 5-21-AS350	

REVISION RECORD				
REV	DATE	DESCRIPTION OF CHANGE	APPVD. BY	REV. BY
C	09/1/14	CHANGED TITLE BLOCK AND REVISION BLOCK. INCORPORATED ECO # 0279 AND 0509.		AJC
D	08/04/23	INCORPORATED ECO'S 1091 AND 1184.		SGB

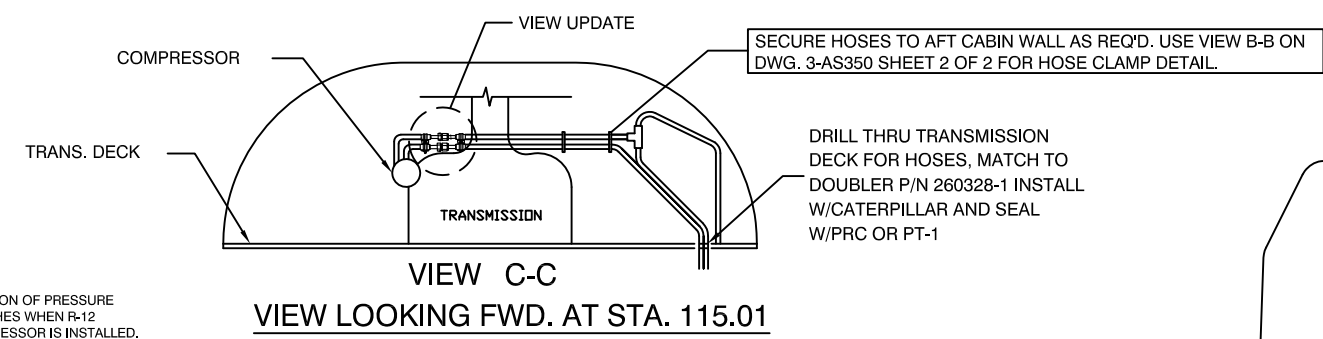

- NOTES:
- 1. LOCATION OF PRESSURE SWITCHES WHEN R-12 COMPRESSOR IS INSTALLED.
 - 2. LOCATION OF PRESSURE SWITCHES WHEN R-134a COMPRESSOR IS INSTALLED.
 - 3. 590001 R-12 FLARE
 - 590001-10" R-12 10" RING
 - 590001-1-0" R-134a W/ESTER OIL
 - 590001-2-0" R134a W/SP-20 OIL
 - 590008 ALT. 590008-1 R-134a W/ESTER OIL
 - 4. ALLOWABLE METRIC HARDWARE FOR HOSE INSTALLATION. HARDWARE QUANTITIES AND LOCATIONS ARE AS REQUIRED.
- VIS: 22201BC050012L
 VIS: 22201BC050014L
 RONDELLE: 231211AG050LE
 ECROU: ASN52320BC050N

VIEW C-C
VIEW LOOKING FWD. AT STA. 115.01

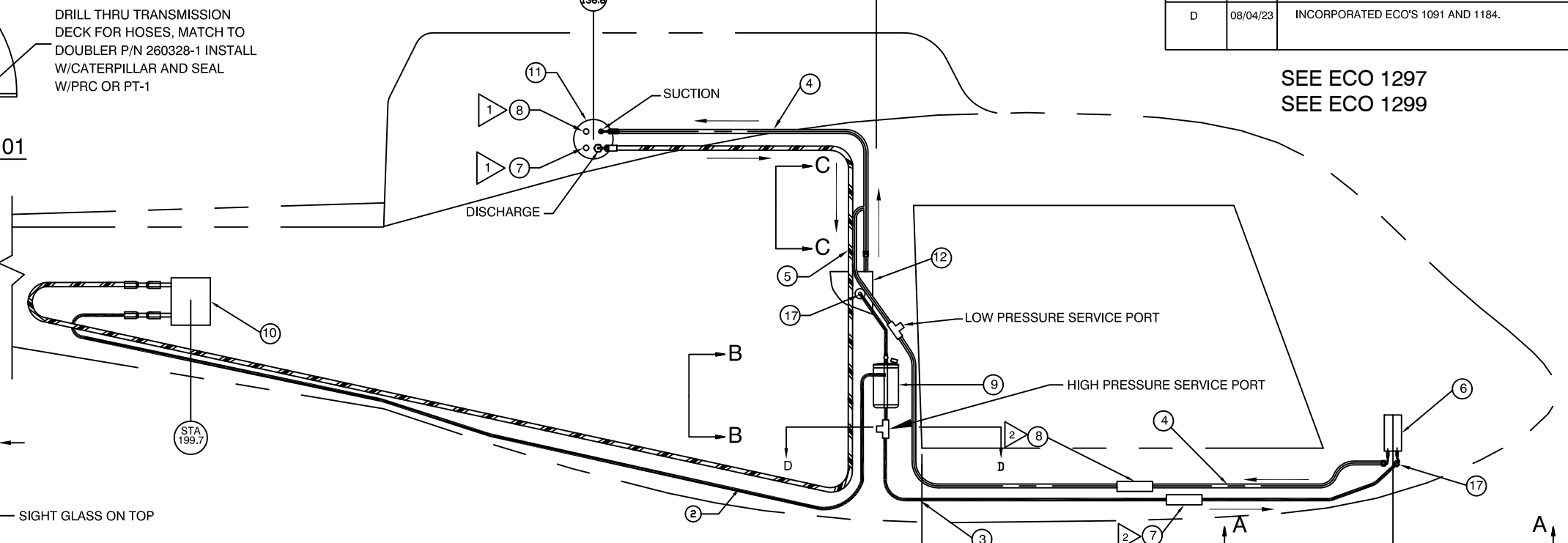

SEE ECO 1297
 SEE ECO 1299

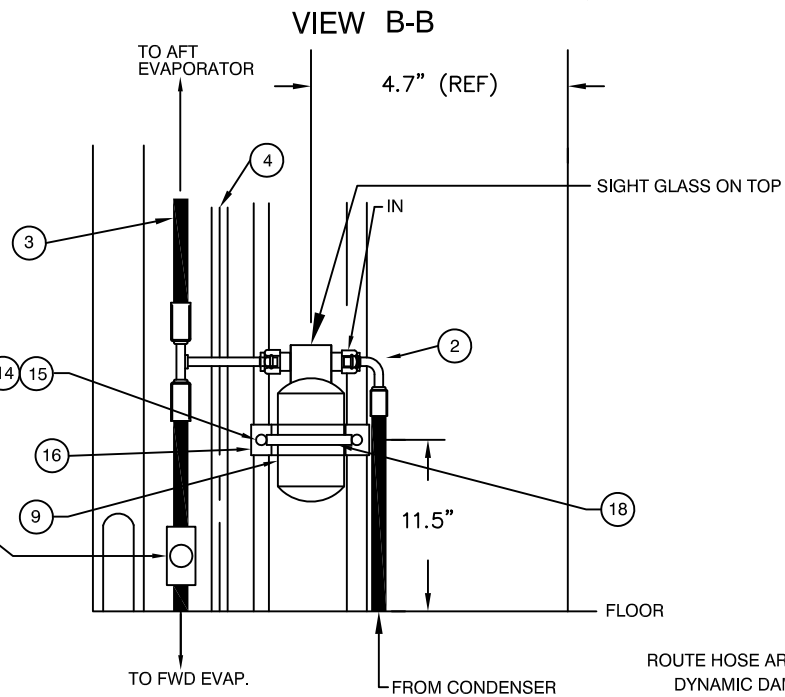

VIEW B-B

VIEW D-D
VIEW LOOKING DOWN

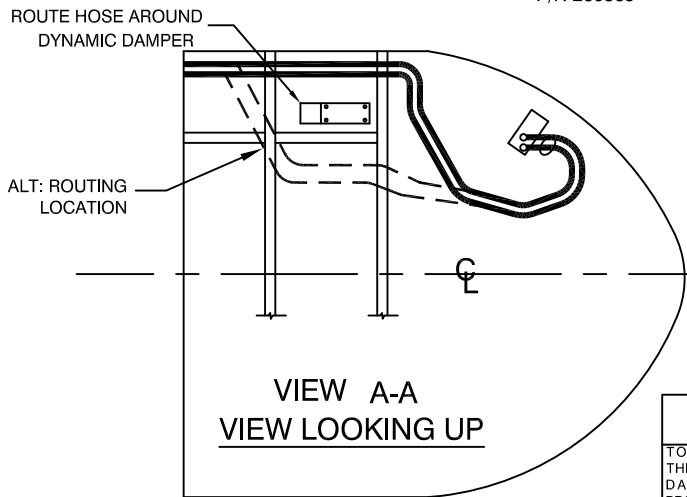
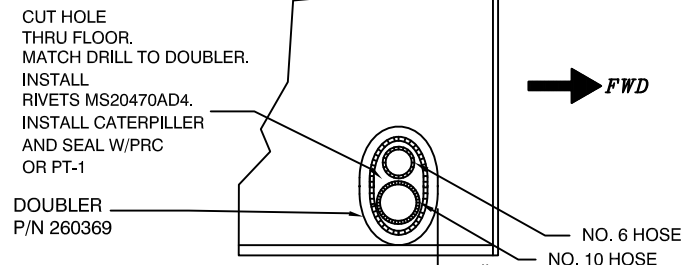

VIEW A-A
VIEW LOOKING UP

QTY	ITEM	PART NUMBER	DESCRIPTION
12	22	MS20470AD4	RIVET
3	21	090094	#10 O-RING
3	20	090093	#8 O-RING
5	19	090092	#6 O-RING
1	18	060036	3 INCH BAND CLAMP
2	17	090002-O	EXPANSION VALVE
1	16	260123-2	RECEIVER DRIER MOUNT
2	15	MS21044-N3	NUT
4	14	AN960-10	WASHER
2	13	AN3-5A	BOLT
1	12	560010-O-5	AFT EVAPORATOR
1	11	590008	COMPRESSOR 24 VDC R-134a O-RING (590008-1)
1	10	5500022	CONDENSER
1	9	090016-5	RECEIVER DRIER BOTTLE
1	8	050107	LOW PRESSURE SWITCH
1	7	090004	HIGH PRESSURE SWITCH
1	6	560025-O	FORWARD EVAPORATOR
1	5	570070-O-A	HOSE ASSY COMPRESSOR TO CONDENSER
1	4	570087-O-A	HOSE ASSY FWD EVAPORATOR TO AFT EVAPORATOR
1	3	570072-O-A	HOSE ASSY. AFT EVAP TO FWD. EVAP TO REC./DRIER
1	2	570067-O-A	HOSE ASSY. COND. TO REC./DRIER

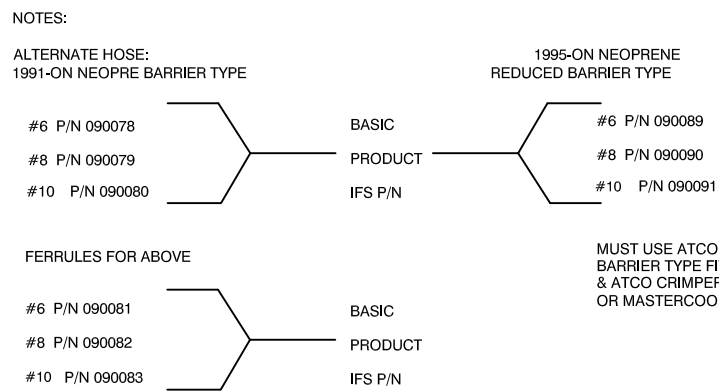

MUST USE ATCO REDUCED BARRIER TYPE FITTINGS & ATCO CRIMPER P/N 3700 OR MASTERCOOL P/N 71500

PROPRIETARY NOTICE

TO ALL PERSONS RECEIVING THIS DOCUMENT THIS DOCUMENT AND INFORMATION OR TECHNICAL DATA AND DESIGNS CONTAINED HEREIN ARE PROPRIETARY DATA AND EXCLUSIVE PROPERTY OF RSG PRODUCTS INC. AND IS DELIVERED ON THE EXPRESS CONDITION THAT NEITHER THIS DOCUMENT NOR THE INFORMATION CONTAINED HEREIN SHALL BE DISCLOSED TO OTHERS, REPRODUCED IN WHOLE OR IN PART, OR USED FOR THE MANUFACTURE OR FABRICATION OF PARTS FOR ANYONE OTHER THAN RSG PRODUCTS INC. WITHOUT WRITTEN CONSENT AND AUTHORIZATION, AND THAT NO RIGHT IS GRANTED TO DISCLOSE OR SO USE ANY INFORMATION CONTAINED IN SAD DOCUMENT. THIS RESTRICTION DOES NOT LIMIT THE RIGHT TO USE INFORMATION OBTAINED FROM ANOTHER SOURCE.

APPROVED BY:

NEXT ASSY.

TOLERANCES EXCEPT AS SHOWN

.X: ±.1
 .XX: ±.03
 .XXX: ±.010
 X.X": ±.5"
 BREAK ALL SHARP EDGES .01
 ALL DIMENSIONS IN INCHES UNLESS OTHERWISE STATED

DATE:

RSG PRODUCTS INC.
 A ROTORCRAFT SERVICES GROUP COMPANY

TITLE:
PLUMBING DIAGRAM

DRAWN BY: **N.DEAN** DATE: **11/01/99** REV.: **D** SCALE: **N/A** SHEET: **1 OF 1**

APPLICATION: **AS350** DWG. NO.: **3-5-AS350**



ENGINEERING CHANGE ORDER

ECO No. 1297 SHT 1 OF 1

DWG No. 3-5-AS350 REV D

DWG No. REV

DWG No. REV

REF. STC No. SH3509SW

CHANGE CLASS:
 RECORD CHG. PARTS NOT AFFECTED NON-INTERCHANGEABLE PARTS
 INTERCHANGEABLE PARTS OTHER _____

EXISTING/IN-WORK STOCK DISPOSITION:
 RECORD CHG. PARTS NOT AFFECTED RE-WORK EXISTING STOCK
 SCRAP EXISTING STOCK OTHER BREAK IN AT NEXT BUILD

EFFECTIVITY:
 ALL UNITS THIS CUSTOMER LIMITED UNITS SPECIFIED
 ALL UNITS MFG'D AFTER THIS DATE OTHER ALL UNITS

DESCRIPTION OF CHANGE: CORRECT TYPO FOR NOTE IN ZN D6.

WAS:

SECURE HOSES TO AFT CABIN WALL AS REQ'D. USE VIEW B-B ON DWG. 3-AS350 SHEET 2 OF 2 FOR HOSE CLAMP DETAIL.

IS:

SECURE HOSES TO AFT CABIN WALL AS REQ'D. USE VIEW B-B ON DWG. 3-15-AS350 SHEET 1 OF 1 FOR HOSE CLAMP DETAIL.

REMARKS: MINOR CHANGE.
CORRECT TYPO.

ENGINEERING REVIEW BOARD		
SIGNATURE	STAMP	DATE
	MRB04	3/4/2024
	QA22 P016	3/5/2024 3/5/2024
INCORPORATION STATUS		
<input type="checkbox"/> IMMEDIATE <input checked="" type="checkbox"/> OUTSTANDING		



ENGINEERING CHANGE ORDER

ECO No.	1299	SHT 1 OF 2
DWG No.	3-5-AS350	REV D
DWG No.		REV
DWG No.		REV

REF. STC No. **SH3509SW**

EFFECTIVITY:
 ALL UNITS THIS CUSTOMER LIMITED UNITS SPECIFIED
 ALL UNITS MFG'D AFTER THIS DATE OTHER ALL UNITS

CHANGE CLASS:
 RECORD CHG. PARTS NOT AFFECTED NON-INTERCHANGEABLE PARTS
 INTERCHANGEABLE PARTS OTHER _____

EXISTING/IN-WORK STOCK DISPOSITION:
 RECORD CHG. PARTS NOT AFFECTED RE-WORK EXISTING STOCK
 SCRAP EXISTING STOCK OTHER BREAK IN AT NEXT BUILD

DESCRIPTION OF CHANGE: ADD INSTALLATION NOTE TO VIEW C-C FOR P/N: 04-130-21-107-01 X2. ALSO ADD DETAIL E FOR INSTALLATION OF P/N: 04-130-21-107-01 X2. ONLY SHOWING WHAT CHANGED FOR CLARITY.

WAS:

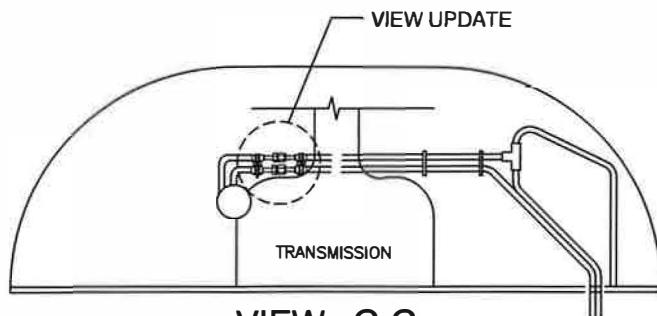

VIEW C-C
VIEW LOOKING FWD. AT STA. 115.01

REMARKS: MINOR CHANGE.
 ADD NOTE AND DETAIL FOR VIEW C-C.

ENGINEERING REVIEW BOARD		
SIGNATURE	STAMP	DATE
	MRB04	4/3/2024
	QA22	4/3/2024
	P016	4/3/2024
INCORPORATION STATUS		
<input type="checkbox"/> IMMEDIATE <input checked="" type="checkbox"/> OUTSTANDING		



ENGINEERING
CHANGE
ORDER

ECO No. 1299	SHT 2 OF 2
DWG No. 3-5-AS350	REV D
DWG No.	REV
DWG No.	REV
REF. STC No. SH3509SW	

IS:

ATTACH P/N 04-130-21-107-01 BRACKET
TO WALL & SECURE HOSES AS REQ'D.
LOCATE FOR BEST FIT. SEE VIEW B-B
ON DWG. 3-15-AS350 FOR HOSE CLAMP
DETAIL. USE HOSE CLAMP
MS21919WDG11 FOR #8 HOSE AND
MS21919WDG12 FOR #10 HOSE

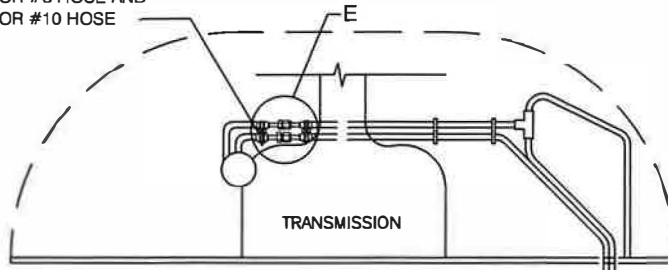

VIEW C-C
VIEW LOOKING FWD. AT STA. 115.01

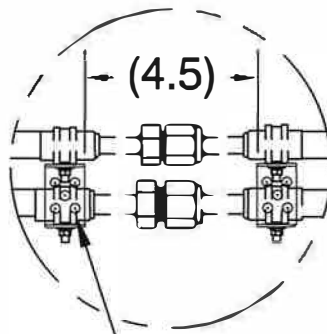

5X MATCH DRILL \varnothing .128 WALL TO P/N:
04-130-21-107-01 BRACKET. INSTALL
MS20470AD4-0 RIVETS.

DETAIL E

Step 6

Installation of Condenser

Installation of Condenser

STEP	PROCEDURE	MECH	INSP
6.1	Remove “tail boom closeout panel” and discard.		
6.2	Prepare to install Air Inlet Doubler L.H. P/N 261013 (<i>if required - contact sales</i>) on the lower left side of the tail boom and Air Inlet Doubler R.H. P/N 261013-2 on the lower right side of the tail boom. Secure doublers per Drawings 7-25 and 26-AS350. NOTE: ALWAYS INSTALL R.H. doubler prior to installing the L.H.		
6.3	Locate station lines 5683 and 5932 on the tail boom. Align the TOP of the inside of the R.H. doubler cut out with the skin lap on the tail boom. Note that the doubler has a taper to it, being wider at the front than at the rear. Tape doubler in place and draw the outline of the inner and outer shape onto the tail boom.		
6.4	Ensure that the doubler will cover all the rivets shown on the install Drawing, both existing and the new rivets that will be added. Adjust as required to maintain 2D edge distance (twice the diameter of hole, from center of hole to edge).		
6.5	Remove stringers on the inside of the tail boom (Drawing 7-22-AS350 within the area of the doubler by drilling out the supporting rivets. These stringers WILL NOT be reused. Drill out all rivets within the area of the doubler.		
6.6	Locate doubler on tail boom as in 6.3. Tape in place. Back drill existing rivet holes to doubler. Cleco doubler in place after first few holes have been drilled. Start a center line and work towards outer edge of doubler.		
6.7	Lay out staggered rows of new rivets around the outer edge of the doubler. Ensure 2D edge distance. Drill through doubler and airframe skin. Remove doubler and deburr all holes. Fit stringers, P/N 261012 and back drill to match skin (see Drawing 7-22-AS350).		
6.8	Rivet doubler in place. Remove airframe skin to the inside edge of the doubler. Deburr, remove any shavings or debris.		
6.9	Install L.H. doubler of the same part number in the same manner as above, ensuring that the widest part of the doubler faces forward.		

Installation of Condenser

STEP	PROCEDURE	MECH	INSP
6.10	<p>Install air inlet screens. Note that R.H. screen is mounted with a strap containing rivnuts, using screws to make that screen removable. This allows accessibility to the tail boom.</p> <p>NOTE: SOME LATE MODEL HELICOPTERS HAVE EUROCOPTER CORPORATION INSTALLED ACCESS DOORS (with screens) ON THE L.H. SIDE, JUST ABOVE WHERE THE DOUBLERS AND SCREENS ARE USUALLY FITTED. THIS AREA MAY BE USED IN LIEU OF THE DOUBLER/SCREEN, FOR AN AIR INTAKE.</p>		
6.11	Lay out and install L.H. and R.H. Air Exit doublers, screens and Air Exit Collars in the same manner as the Air Inlets per Drawings 7-23-AS350 and 7-24-AS350.		
6.12	Position condenser support, channel, forward P/N 261080 five (5) inches above the aft baggage floor (as measured from the floor to the top of the channel) per 7-22-AS350. Level channel and re-check measurements. Clamp in place.		
6.13	Position condenser support, channel, aft P/N 261081 aft of the next frame in tail boom. Level to support, channel, forward and clamp in place.		
6.14	Ensure that both channels are equally spaced off the center line of the airframe and that the pre-drilled mounting holes in the channels allow a minimum of 2D edge distance in the frames they are to be mounted to. Scribe through the holes in both channels to the airframe. Remove channels and drill all right (8) mounting holes, Deburr.		
6.15	Mount the aft and forward channels using the specified hardware. Remove 5" Blowers and temporarily install condenser assembly P/N 550022 in place and note any areas of interference.		
6.16	Mark two (2) hole locations in condenser, at each lower outboard corner. Centering on top flange of mounting channel. Drill holes (Drawing 7-22-AS350). Place AN3-5A bolt in hole until trial fitting is complete.		
6.17	Temporarily mount both condenser blowers and ensure alignment with each air exit collar, P/N 250324. Remove blowers and condenser until refrigerant hoses have been connected and leak tested.		

RSG Products Inc.
INSTALLATION OF CONDENSER – AS350 Air Conditioning

Installation of Condenser

STEP	PROCEDURE	MECH	INSP
6.18	Reinstall the condenser after all hoses have been connected and leak tested.		
6.19	Install dual condenser blowers P/N IFSS 050143-2 or -3 DCB. Use one mounting screw as ground for each blower.		
6.20	Fit condenser air exit flex duct over blower and onto air exit collar. Install band clamps to secure flex duct.		
6.21	Install Baggage Compartment Close Out Panel P/N 250301 per drawing 7-22-AS350.		

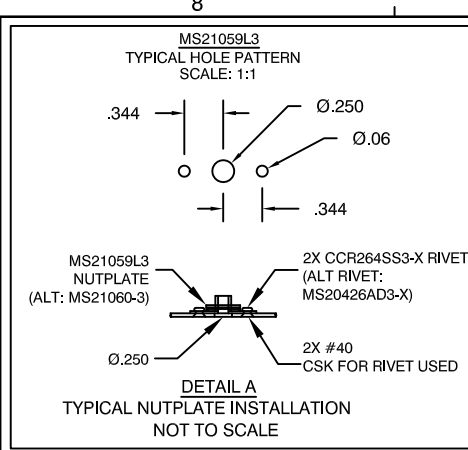

- NOTES**
1. SEAL DOUBLERS AND SCREENS WITH PRC AS NECESSARY FOR CORROSION PREVENTION
 2. EMI FILTER KIT P/N: 050143-3. (SEE TABLE 1)

TABLE 1
FILTER KIT P/N: 050143-3

ITEM DESCRIPTION	PART NUMBER	QTY
FILTER	13619-RF16883	2
EMI FILTER PLACARD	13619-RF16883P	2
CHERRY NUT PLATE RIVET	CCR264CS3-02	8
NUT PLATE	MS21075-3N	4
SCREW, #8-32	MS27039-0807	4
WASHER	NAS620-8L	4

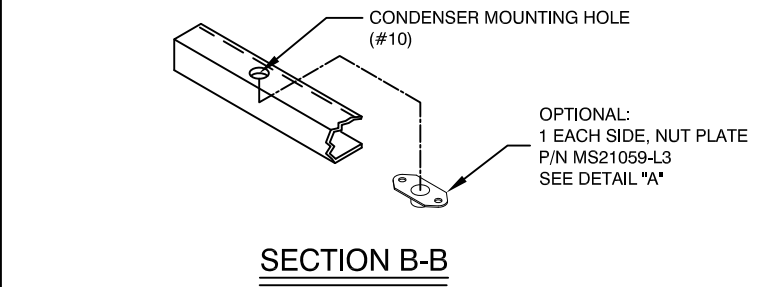

BURNISHING REQUIREMENTS:
REMOVE PROTECTIVE FINISH LOCALLY FROM SURFACES WHERE EQUIPMENT MOUNTING HOLES ARE LOCATED, TO ASSURE A PROPER ELECTRICAL BOND MEASURING A MAXIMUM OF 2.5 MILLIOHMS.

OPTIONAL INSTALL FOR NOISE REDUCTION WHEN BRUSHLESS MOTORS ARE INSTALLED; P/Ns: IFSS 050143 DCB, -1 DCB, -2 DCB, AND -3 DCB.
INSTALL THE FOLLOWING, MAINTAINING BURNISHING REQ:
13619-RF16883 (EMI FILTER) 2EA
MS27039-0807 (SCREW) 4EA
NAS620-8L (WASHER) 4EA

REMOVE EXISTING STRINGERS IN AREA WHERE DOUBLERS ARE TO BE INSTALLED. INSTALL NEW IFS STRINGERS P/N 261012, AS SHOWN.

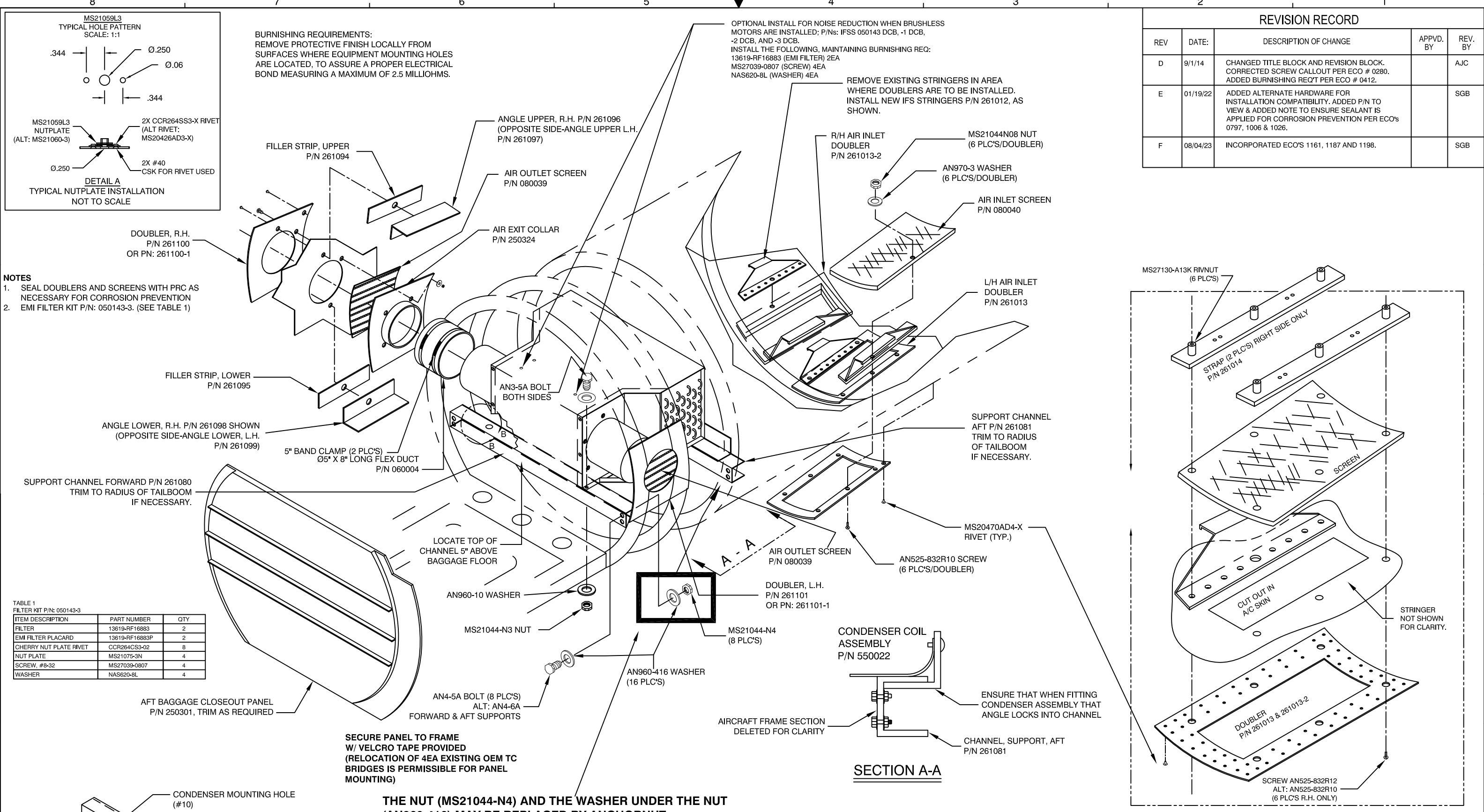

THE NUT (MS21044-N4) AND THE WASHER UNDER THE NUT (AN960-416) MAY BE REPLACED BY ANCHORNUT (MS21075L4N) AND RIVETS (MS20426AD3-5) AT THIS SPECIFIC LOCATION ON THE AIRCRAFT WHILE ON THE AHI H125 FAL WHEN THERE IS A CONFLICT WITH STC SR00422NY. THE ANCHORNUT WILL BE MOUNTED TO THE FRONT SIDE OF THE TAILBOOM FRAME AND THE BOLT INSTALLED FROM THE REAR.

REVISION RECORD

REV	DATE	DESCRIPTION OF CHANGE	APPVD. BY	REV. BY
D	9/1/14	CHANGED TITLE BLOCK AND REVISION BLOCK. CORRECTED SCREW CALLOUT PER ECO # 0280. ADDED BURNISHING REQ PER ECO # 0412.		AJC
E	01/19/22	ADDED ALTERNATE HARDWARE FOR INSTALLATION COMPATIBILITY. ADDED P/N TO VIEW & ADDED NOTE TO ENSURE SEALANT IS APPLIED FOR CORROSION PREVENTION PER ECO'S 0797, 1006 & 1026.		SGB
F	08/04/23	INCORPORATED ECO'S 1161, 1187 AND 1198.		SGB

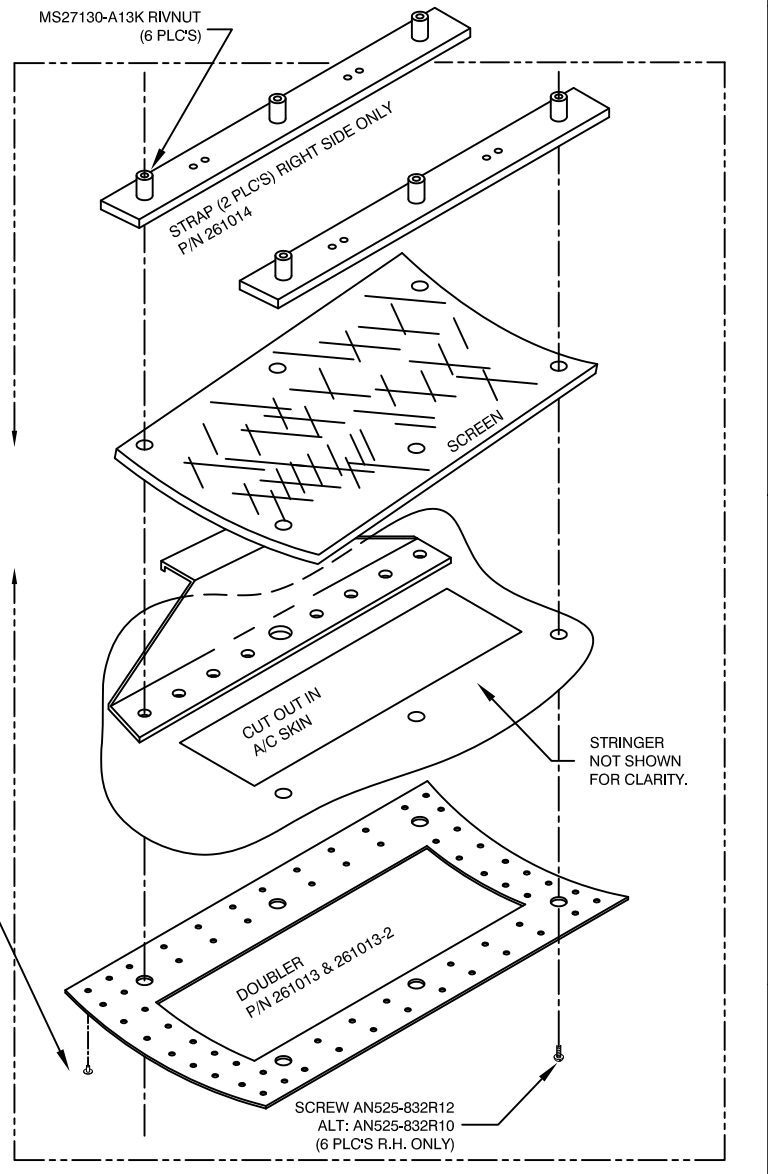

PROPRIETARY NOTICE

TO ALL PERSONS RECEIVING THIS DOCUMENT THIS DOCUMENT AND INFORMATION OR TECHNICAL DATA AND DESIGNS CONTAINED HEREIN ARE PROPRIETARY DATA AND EXCLUSIVE PROPERTY OF RSG PRODUCTS INC. AND IS DELIVERED ON THE EXPRESS CONDITION THAT NEITHER THIS DOCUMENT NOR THE INFORMATION CONTAINED HEREIN SHALL BE DISCLOSED TO OTHERS, REPRODUCED IN WHOLE OR IN PART, OR USED FOR THE MANUFACTURE OR FABRICATION OF PARTS FOR ANYONE OTHER THAN RSG PRODUCTS INC. WITHOUT WRITTEN CONSENT AND AUTHORIZATION, AND THAT NO RIGHT IS GRANTED TO DISCLOSE OR SO USE ANY INFORMATION CONTAINED IN SAD DOCUMENT. THIS RESTRICTION DOES NOT LIMIT THE RIGHT TO USE INFORMATION OBTAINED FROM ANOTHER SOURCE.

APPROVED BY:

DATE:

RSG PRODUCTS INC.
A ROTORCRAFT SERVICES GROUP COMPANY

TITLE:
INSTALLATION CONDENSER

DRAWN BY: KML	DATE: 11/10/96	REV.: F	SCALE: N/A	SHEET: 1 OF 1
APPLICATION: AS350			DWG. NO.: 7-22-AS350	

NOTES:

- IF A STRAP TYPE DOUBLER HAS BEEN INSTALLED BY THE MANUFACTURER AT THE SPLICE POINT BETWEEN THE FUSELAGE AND TAILBOOM, SEE IFS DRAWING 7-29-AS350 FOR INSTALLATION OF THIS DOUBLER
- IF STROBE POWERPACK IS IN THE 3 O'CLOCK POSITION, RELOCATE TO THE 2 O'CLOCK POSITION.
- RIVET LENGTHS MAYBE DETERMINED UPON INSTALLATION. INTERCHANGEABILITY BETWEEN MS20470AD RIVET AND CR3234 OR CR3243 RIVETS IS APPROVED
- LOCATE EXISTING RIVET PATTERN AS SHOWN AND POSITION DOUBLER.
- MARK AROUND DOUBLER, REMOVE DOUBLER AND REMOVE ANY RIVETS INSIDE MARKING.
- RE-POSITION DOUBLER, BACK DRILL DOUBLER AND CLECO IN PLACE.
- CUT OUT CENTER HOLE.
- MARK OUT 8 RIVET LOCATIONS EQUALLY SPACED IN LINE WITH TOP FWD AND AFT EXISTING RIVETS.
- NOTE: IF ANY EXISTING HOLE PATTERNS EXIST UNDER THE DOUBLER, USE THESE AS PATTERN FOR ADDED ROWS IN THE FOLLOWING STEPS.
- ADD A 2nd ROW OF 8 RIVETS EQUALLY SPACED APPROX. 1" DOWN IN LINE WITH FWD AND AFT EXISTING RIVETS. (IF THERE IS AN EXISTING ROW, USE THIS ROW AND EXTRA RIVETS). ALSO DRILL UPPER ANGLE PN: 261096 AND FILLER PN: 261094.
- MARK OUT 7 RIVET LOCATIONS EQUALLY SPACED ON BOTTOM ROW IN LINE WITH BOTTOM FWD AND AFT EXISTING RIVETS.
- ADD 2nd ROW OF 8 EQUALLY SPACED RIVETS APPROX. 1" UP. ALSO DRILL IN LOWER ANGLE PN: 261098 AND FILLER PN: 261095.
- ADD 3rd ROW OF 7 EQUALLY SPACED RIVETS .8" UP.
- SEAL DOUBLERS AND SCREEN WITH PRC AS NECESSARY FOR CORROSION PREVENTION.

RIVET LEGEND:

- ⊙ MS20470AD5-X RIVET EXISTING
- ⊕ MS20470AD5-X RIVET
- MS20470AD4-X RIVET
- MS20470AD4-X RIVET

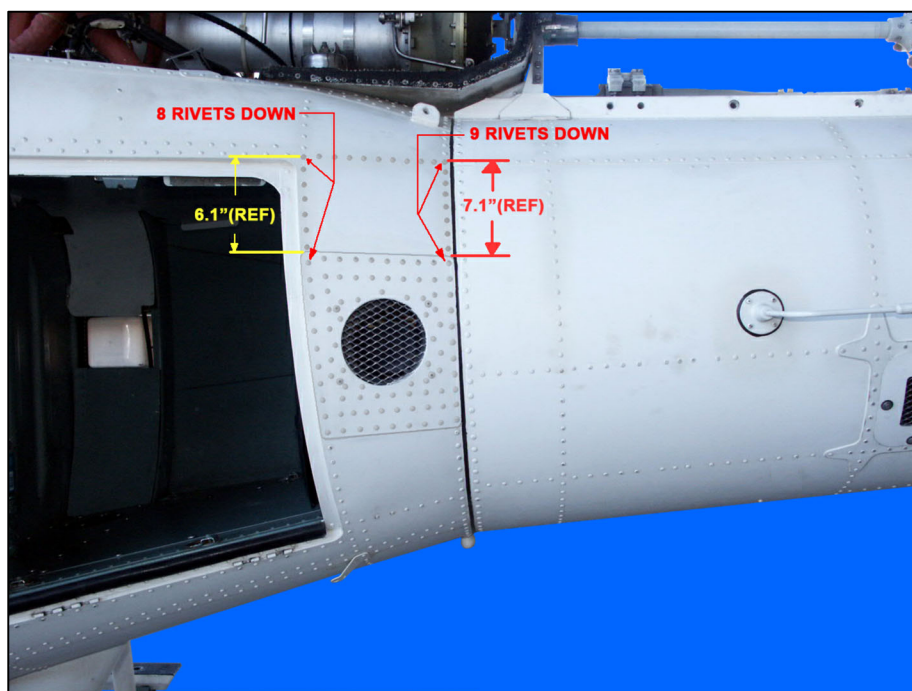

BAGGAGE DOOR OPENING
FWD ←

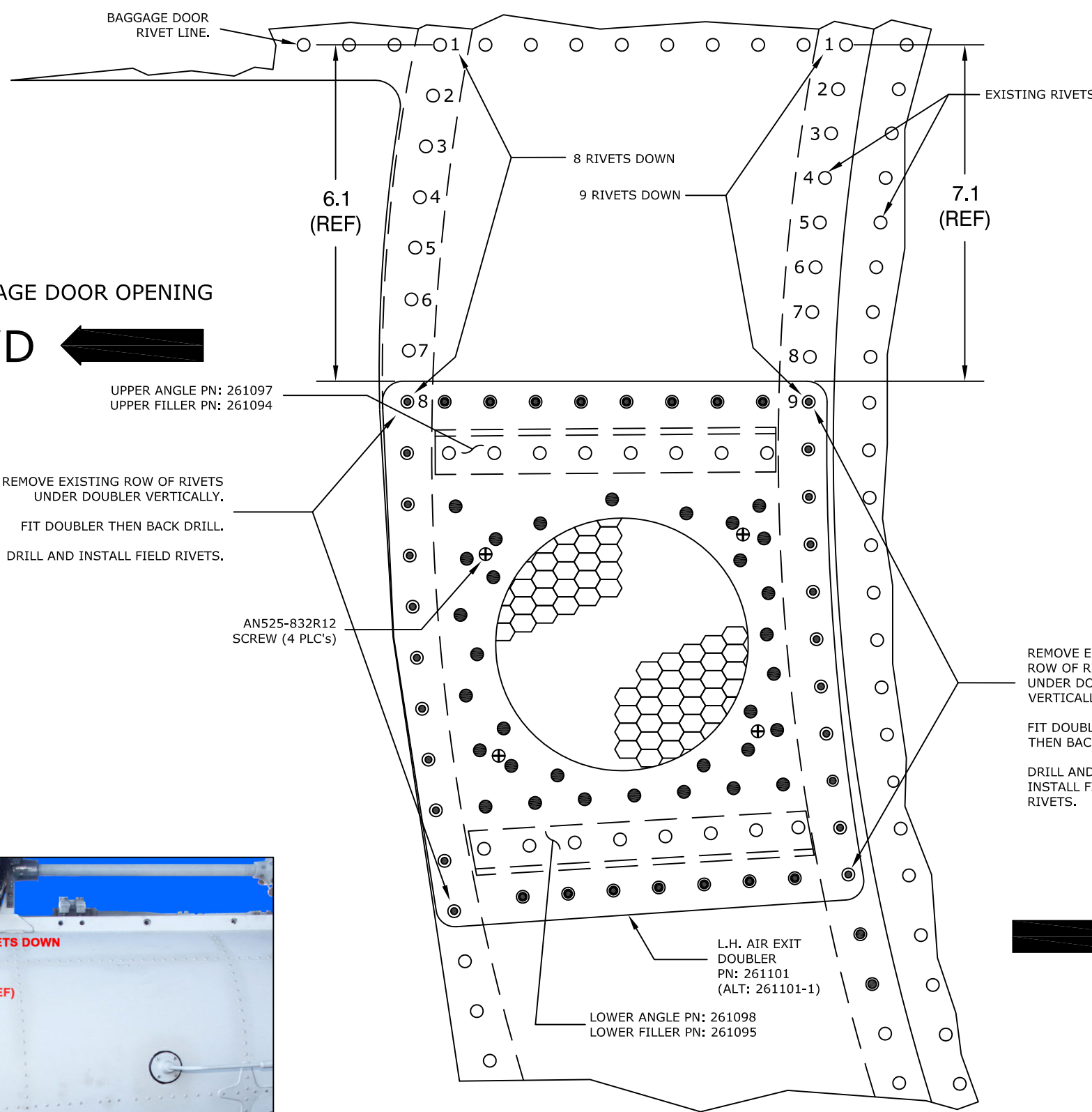

→ AFT

REVISION RECORD

REV	DATE	DESCRIPTION OF CHANGE	APPVD. BY	REV. BY
A	08/16/00	CONVERTED INTO AUTOCAD, REVISED DRAWING NO. WAS 7-AS355, SHEET 3 OF 5.		
B	04/03/02	REMOVED AS355 NOTES. REMOVED LINEAR DIMENSIONS FOR PLATE ALIGNMENT. ADDED RIVET COUNT FOR PLATE ALIGNMENT. REVISED TITLE BLOCK.		
C	01/03/07	CHANGED RIVET COUNT. ADDED REFERENCE DIMENSIONS FOR PLATE ALIGNMENT. ADDED NOTES 3 - 12.		JTYE
D	06/30/08	ADDED NEW NOTE 1., RENUMBERED FOLLOWING NOTES. ADDED ALT. DOUBLER PN: 261101-1. REVISED TITLE BLOCK.		JTYE
E	9/1/14	CHANGED TITLE BLOCK AND REVISION BLOCK.		AJC
F	08/04/23	INCORPORATED ECO 1231.		SGB

PROPRIETARY NOTICE

TO ALL PERSONS RECEIVING THIS DOCUMENT THIS DOCUMENT AND INFORMATION OR TECHNICAL DATA AND DESIGNS CONTAINED HEREIN ARE PROPRIETARY DATA AND EXCLUSIVE PROPERTY OF RSG PRODUCTS INC. AND IS DELIVERED ON THE EXPRESS CONDITION THAT NEITHER THIS DOCUMENT NOR THE INFORMATION CONTAINED HEREIN SHALL BE DISCLOSED TO OTHERS, REPRODUCED IN WHOLE OR IN PART, OR USED FOR THE MANUFACTURE OR FABRICATION OF PARTS FOR ANYONE OTHER THAN RSG PRODUCTS INC. WITHOUT WRITTEN CONSENT AND AUTHORIZATION, AND THAT NO RIGHT IS GRANTED TO DISCLOSE OR SO USE ANY INFORMATION CONTAINED IN SAD DOCUMENT. THIS RESTRICTION DOES NOT LIMIT THE RIGHT TO USE INFORMATION OBTAINED FROM ANOTHER SOURCE.

NEXT ASSY.

TOLERANCES EXCEPT AS SHOWN

.X: ±.1
.XX: ±.03
.XXX: ±.010
X.X": ±.5°
BREAK ALL SHARP EDGES .01
ALL DIMENSIONS IN INCHES UNLESS OTHERWISE STATED
DATE:

APPROVED BY:



TITLE:
L.H. AIR EXIT DOUBLER INSTALL

DRAWN BY: KML DATE: 11/10/96 REV.: F SCALE: N/A SHEET: 1 OF 1

APPLICATION: AS350 DWG. NO.: 7-23-AS350

NOTES:

1. IF A STRAP TYPE DOUBLER HAS BEEN INSTALLED BY THE MANUFACTURER AT THE SPLICE POINT BETWEEN THE FUSELAGE AND TAILBOOM, SEE IFS DRAWING 7-28-AS350 FOR INSTALLATION OF THIS DOUBLER
2. RIVET LENGTHS MAYBE DETERMINED UPON INSTALLATION, INTERCHANEABILITY BETWEEN MS20470AD RIVET AND CR3234 OR CR3243 RIVETS IS APPROVED.
3. SEAL DOUBLERS AND SCREEN WITH PRC AS NECESSARY FOR CORROSION PREVENTION.

RIVET LEGEND:

- ⊙ MS20470AD5-X RIVET EXISTING
- ⦿ MS20470AD5-X RIVET
- MS20470AD4-X RIVET
- MS20470AD4-X RIVET



AFT ←

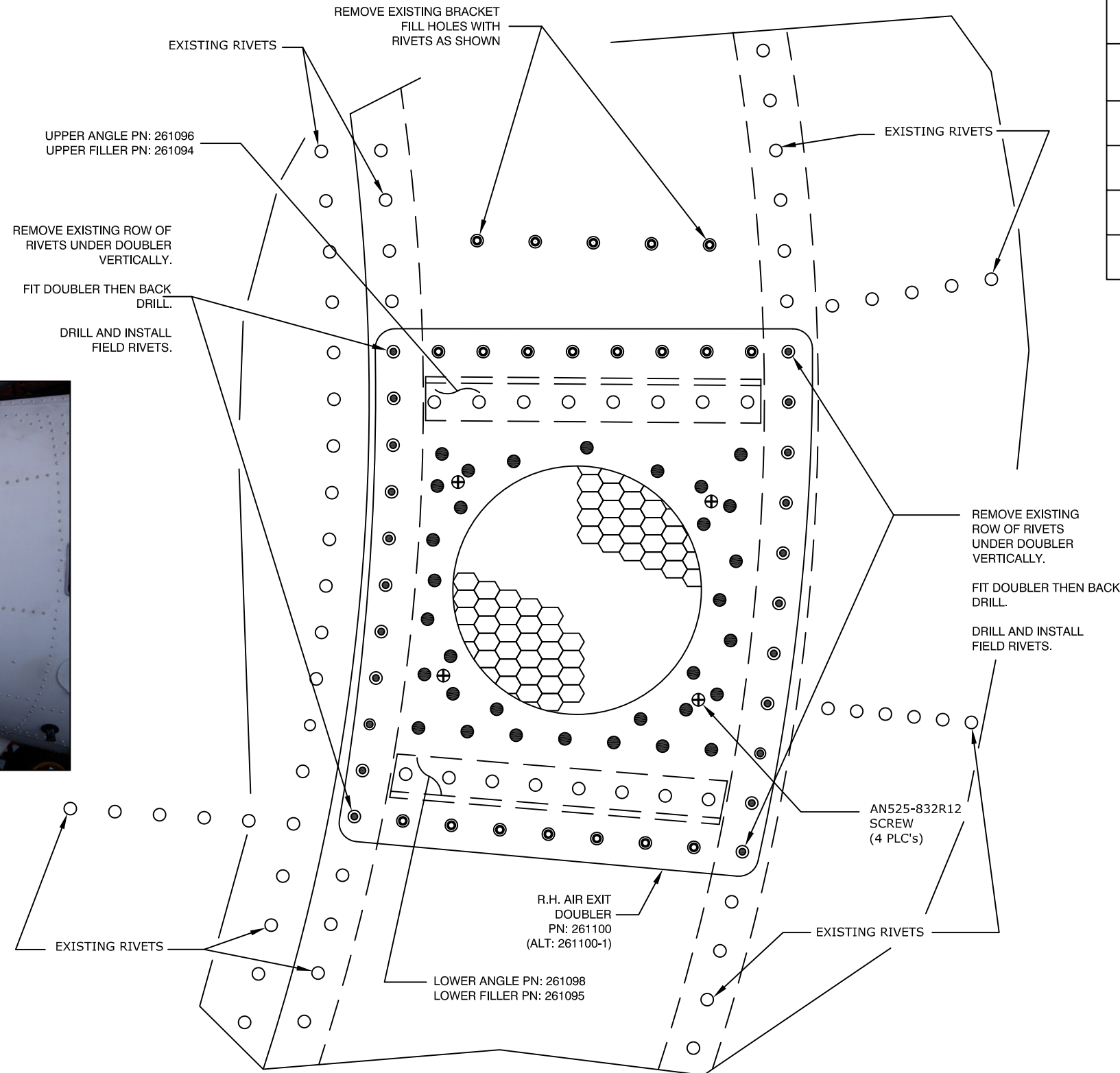

→ **FWD**

REVISION RECORD

REV	DATE	DESCRIPTION OF CHANGE	APPVD. BY	REV. BY
A	08/16/00	CONVERTED INTO AUTOCAD, REVISED DRAWING NO. WAS 7-AS355, SHEET 3 OF 5.		
B	04/03/02	REMOVED AS355 NOTES. REMOVED LINEAR DIMENSIONS FOR PLATE ALIGNMENT. ADDED RIVET COUNT FOR PLATE ALIGNMENT. REVISED TITLE BLOCK.		
C	01/03/07	REMOVED RIVET COUNT. ADDED REFERENCE PHOTO FOR PLATE ALIGNMENT.		JTYE
D	06/30/08	ADDED NEW NOTE 1., RENUMBERED FOLLOWING NOTES. ADDED ALT. DOUBLER PN: 261100-1. REVISED TITLE BLOCK.		JTYE
E	9/1/14	CHANGED TITLE BLOCK AND REVISION BLOCK.		AJC
F	08/04/23	INCORPORATED ECO 1232		SGB

PROPRIETARY NOTICE

TO ALL PERSONS RECEIVING THIS DOCUMENT THIS DOCUMENT AND INFORMATION OR TECHNICAL DATA AND DESIGNS CONTAINED HEREIN ARE PROPRIETARY DATA AND EXCLUSIVE PROPERTY OF RSG PRODUCTS INC. AND IS DELIVERED ON THE EXPRESS CONDITION THAT NEITHER THIS DOCUMENT NOR THE INFORMATION CONTAINED HEREIN SHALL BE DISCLOSED TO OTHERS, REPRODUCED IN WHOLE OR IN PART, OR USED FOR THE MANUFACTURE OR FABRICATION OF PARTS FOR ANYONE OTHER THAN RSG PRODUCTS INC. WITHOUT WRITTEN CONSENT AND AUTHORIZATION, AND THAT NO RIGHT IS GRANTED TO DISCLOSE OR SO USE ANY INFORMATION CONTAINED IN SAD DOCUMENT. THIS RESTRICTION DOES NOT LIMIT THE RIGHT TO USE INFORMATION OBTAINED FROM ANOTHER SOURCE.

NEXT ASSY.

TOLERANCES EXCEPT AS SHOWN

- .X: ±.1
- .XX: ±.03
- .XXX: ±.010
- X.X°: ±.5°
- BREAK ALL SHARP EDGES .01
- ALL DIMENSIONS IN INCHES UNLESS OTHERWISE STATED

APPROVED BY:

DATE:



TITLE:
R.H.AIR EXIT DOUBLER INSTALL

DRAWN BY: **CS** DATE: **11/10/95** REV.: **F** SCALE: **N/A** SHEET: **1 OF 1**

APPLICATION: **AS350** DWG. NO.: **7-24-AS350**

DOUBLER INSTALL

1. LOCATE DOUBLER ON TAIL BOOM, EQUALLY BETWEEN FRAMES. ENSURE THAT INNER, TOP EDGE OF DOUBLER CUT OUT IS PARALLEL TO HELICOPTER SKIN LAP. TRACE DOUBLER OUTLINE.
2. REMOVE ALL RIVETS IN FORWARD AND AFT VERTICAL ROWS COVERED BY DOUBLER.
3. BACK DRILL DOUBLER TO BOTH EXISTING VERTICAL ROWS OF RIVET HOLES.
4. CLECO DOUBLER IN PLACE.
5. ADD TOP AND BOTTOM ROW OF RIVETS ON INNER PERIMETER ON SAME SPACING AS VERTICAL ROWS OR AS SHOWN.
6. ADD NEW RIVETS AROUND OUTER PERIMETER OF DOUBLER, STAGGERING RIVETS BETWEEN INNER ROW.
7. MAINTAIN 2.0 DIAMETER EDGE DISTANCE ON ALL RIVETS, AT ALL LOCATIONS.
8. SEE LEGEND FOR RIVET SIZE, TYPE, AND LOCATION.
9. WHEN AN AMERICAN EUROCOPTER ACCESS PANEL, P/N: 355A23-2010-21, AND DOUBLER, P/N: 355A23-2010-20, IS INSTALLED THE INSTALLATION OF IFS DOUBLER P/N: 261012, CANNOT BE INSTALLED ON L.H. SIDE AS SHOWN. MODIFY AMERICAN EUROCOPTER ACCESS PANEL P/N: 355A23-2010-21 USING IFS SUPPLIED SCREEN, P/N: 080040, AS SHOWN IN VIEW A-A. REINSTALL MODIFIED ACCESS PANEL AS AN ALTERNATE AIR INTAKE ON LEFT SIDE OF TAIL BOOM.

NOTES:

INSTALL R.H. DOUBLER BEFORE L.H.

RIVET LENGTHS MAYBE DETERMINED UPON INSTALLATION, INTERCHANGEABILITY BETWEEN MS20470AD RIVET AND CR3242 OR CR3243 RIVETS IS APPROVED.

RIVET LEGEND:

- MS20470AD4-X RIVET (EXISTING, REMOVE, & REPLACE)
- MS20470AD4-X RIVET (NEW)

FWD ←

→ **AFT**

EXISTING RIVETS

STA. 5683

STA. 5932

EXISTING RIVETS

AN525-832R10 SCREW
AN970-3 WASHER
MS21044N08 NUT
(6 PLACES)

ADD RIVET AT EACH CORNER (4 PLACES)

CUTOUT A/C SKIN TO MATCH INSIDE OF DOUBLER AFTER COMPLETION OF RIVETS.

DOUBLER, AIR INLET
P/N 261013

AIR INLET DOUBLER, L.H.

REVISION RECORD

REV	DATE	DESCRIPTION OF CHANGE	APPVD. BY	REV. BY
A	08/16/00	REVISED DRAWING, WAS DRAWING NO. 7-AS355 SH 4 OF 5. ADDED NOTE 9. ADDED VIEW A-A.		
B	06/15/03	CONVERTED TO AUTOCAD, CHANGED TITLE BLOCK.		JTYE
C	02/14/09	CORRECTED RIVET LEGEND. REVISED TITLE BLOCK.	MLD	JTYE
D	9/1/14	CHANGED TITLE BLOCK AND REVISION BLOCK. CORRECTED HARDWARE PER ECO # 0281.		AJC
E	01/19/22	UPDATED VIEW A-A FOR INSTALLATION IMPROVEMENT FOR SCREEN P/N 080040 PER ECO 1014.		SGB

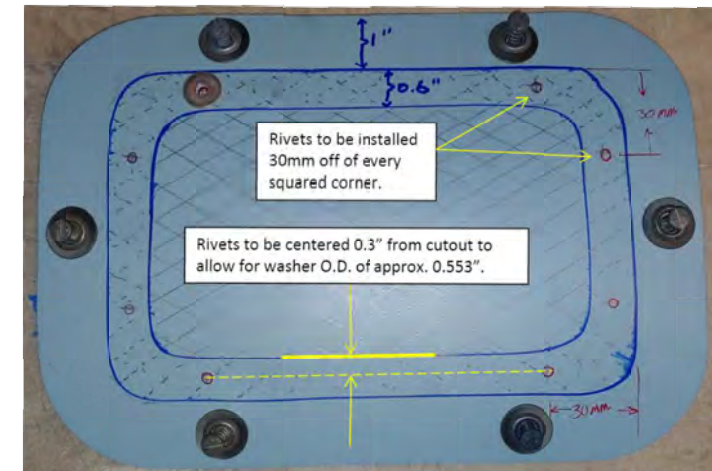

VIEW A-A

INSTALLATION INSTRUCTIONS:

1. CUT OUT ACCESS PANEL LEAVING 1.6 MIN MATERIAL AROUND EDGE.
2. TRIM SCREEN P/N 080040 TO MATCH CUTOUT IN TAILBOOM.
3. INSTALL SCREEN P/N 080040 ONTO AFT SIDE OF PANEL P/N 355A2320100201 USING (8) MBBN3012L4004 RIVETS AND (8) NFL23116AG040LE WASHERS.

PROPRIETARY NOTICE

TO ALL PERSONS RECEIVING THIS DOCUMENT THIS DOCUMENT AND INFORMATION OR TECHNICAL DATA AND DESIGNS CONTAINED HEREIN ARE PROPRIETARY DATA AND EXCLUSIVE PROPERTY OF RSG PRODUCTS INC. AND IS DELIVERED ON THE EXPRESS CONDITION THAT NEITHER THIS DOCUMENT NOR THE INFORMATION CONTAINED HEREIN SHALL BE DISCLOSED TO OTHERS, REPRODUCED IN WHOLE OR IN PART, OR USED FOR THE MANUFACTURE OR FABRICATION OF PARTS FOR ANYONE OTHER THAN RSG PRODUCTS INC. WITHOUT WRITTEN CONSENT AND AUTHORIZATION, AND THAT NO RIGHT IS GRANTED TO DISCLOSE OR SO USE ANY INFORMATION CONTAINED IN SAD DOCUMENT. THIS RESTRICTION DOES NOT LIMIT THE RIGHT TO USE INFORMATION OBTAINED FROM ANOTHER SOURCE.

NEXT ASSY.

TOLERANCES EXCEPT AS SHOWN

.X: ±.1
.XX: ±.03
.XXX: ±.010
X.X°: ±.5°
BREAK ALL SHARP EDGES .01
ALL DIMENSIONS IN INCHES UNLESS OTHERWISE STATED

APPROVED BY:

DATE:



TITLE:
INSTALLATION AIR INLET DOUBLER L.H.

DRAWN BY: CS DATE: 11/10/96 REV.: E SCALE: N/A SHEET: 1 OF 1

APPLICATION: AS350 DWG. NO.: 7-25-AS350

REVISION RECORD				
REV	DATE	DESCRIPTION OF CHANGE	APPVD. BY	REV. BY
A	08/16/00	REVISED DRAWING NO., WAS 7-AS 355 SHEET 5 OF 5.		
B	08/16/00	CONVERTED TO AUTOCAD, CHANGED TITLE BLOCK.		
C	02/14/09	CHANGED P/N: 261013 TO 261013-2. UPDATED TITLE BLOCK. CORRECTED RIVET LEGEND. CHANGED RIVET DESIGNATIONS ON DOUBLER INSTALL. REVISED TITLE BLOCK.		DWE
D	9/1/14	CHANGED TITLE BLOCK AND REVISION BLOCK. CORRECTED HARDWARE CALLOUT PER ECO # 0282		AJC

- DOUBLER INSTALL**
1. LOCATE DOUBLER ON TAIL BOOM, EQUALLY BETWEEN FRAMES. ENSURE THAT INNER, TOP EDGE OF DOUBLER CUT OUT IS PARALLEL TO HELICOPTER SKIN LAP. TRACE DOUBLER OUTLINE.
 2. REMOVE ALL RIVETS IN FORWARD AND AFT VERTICAL ROWS COVERED BY DOUBLER.
 3. BACK DRILL DOUBLER TO BOTH EXISTING VERTICAL ROWS OF RIVET HOLES.
 4. CLECO DOUBLER IN PLACE.
 5. ADD TOP AND BOTTOM ROW OF RIVETS ON INNER PERIMETER ON SAME SPACING AS VERTICAL ROWS OR AS SHOWN.
 6. ADD NEW RIVETS AROUND OUTER PERIMETER OF DOUBLER, STAGGERING RIVETS BETWEEN INNER ROW.
 7. MAINTAIN 2.0 DIAMETER EDGE DISTANCE ON ALL RIVETS, AT ALL LOCATIONS.
 8. SEE LEGEND FOR RIVET SIZE, TYPE, AND LOCATION.

NOTES:

INSTALL R.H. DOUBLER BEFORE L.H.

RIVET LENGTHS MAYBE DETERMINED UPON INSTALLATION. INTERCHANGEABILITY BETWEEN MS20470AD RIVET AND CR3242 OR CR3243 RIVETS IS APPROVED.

RIVET LEGEND:	
●	MS20470AD4-X RIVET (EXISTING, REMOVE, & REPLACE)
○	MS20470AD4-X RIVET (NEW)

AFT ←



FWD

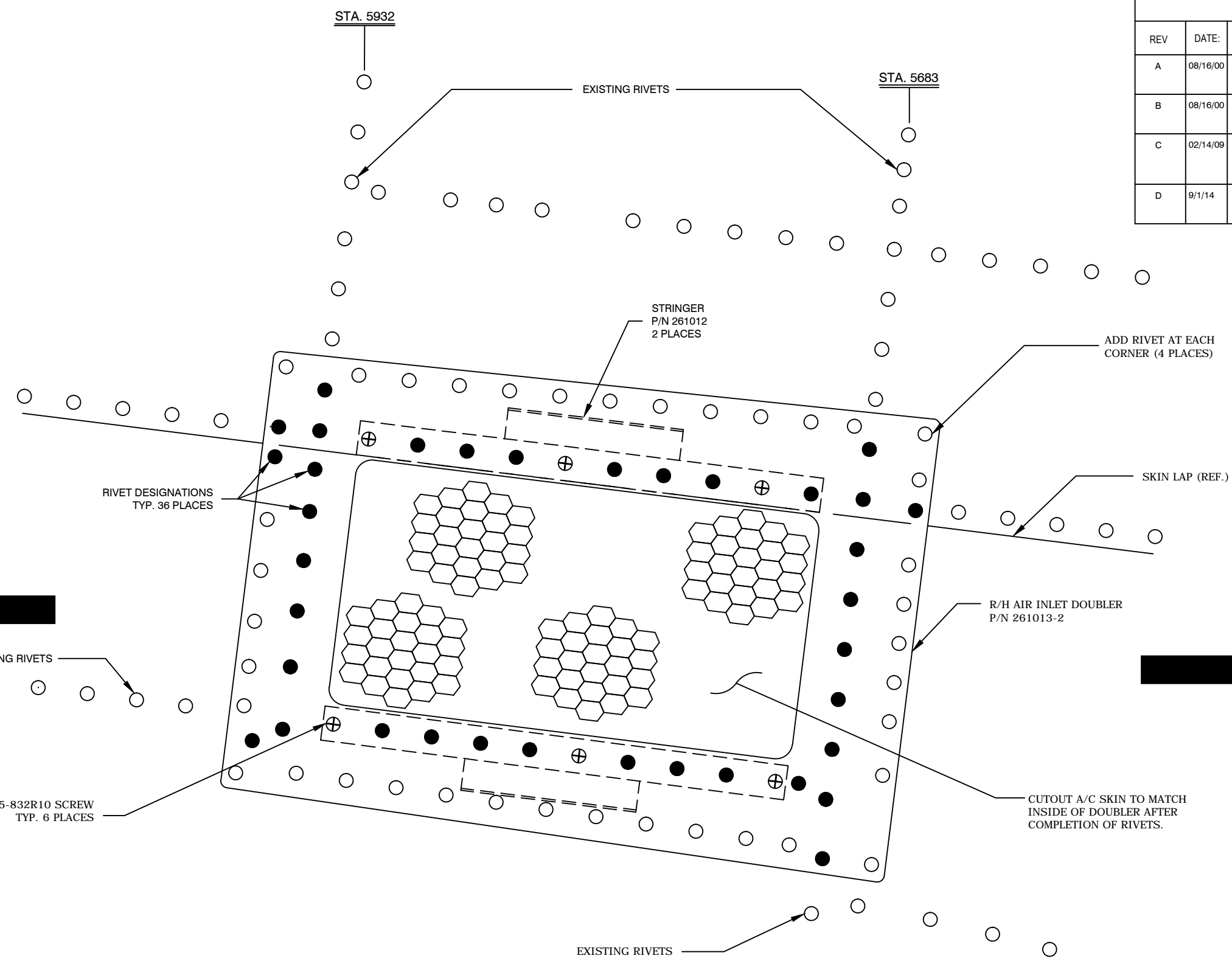

AIR INLET DOUBLER, R.H.

<p>PROPRIETARY NOTICE</p> <p>TO ALL PERSONS RECEIVING THIS DOCUMENT THIS DOCUMENT AND INFORMATION OR TECHNICAL DATA AND DESIGNS CONTAINED HEREIN ARE PROPRIETARY DATA AND EXCLUSIVE PROPERTY OF RSG PRODUCTS INC. AND IS DELIVERED ON THE EXPRESS CONDITION THAT NEITHER THIS DOCUMENT NOR THE INFORMATION CONTAINED HEREIN SHALL BE DISCLOSED TO OTHERS, REPRODUCED IN WHOLE OR IN PART, OR USED FOR THE MANUFACTURE OR FABRICATION OF PARTS FOR ANYONE OTHER THAN RSG PRODUCTS INC. WITHOUT WRITTEN CONSENT AND AUTHORIZATION, AND THAT NO RIGHT IS GRANTED TO DISCLOSE OR SO USE ANY INFORMATION CONTAINED IN SAD DOCUMENT. THIS RESTRICTION DOES NOT LIMIT THE RIGHT TO USE INFORMATION OBTAINED FROM ANOTHER SOURCE.</p>	NEXT ASSY.	TOLERANCES EXCEPT AS SHOWN							
		.X: ±.1 .XX: ±.03 .XXX: ±.010 X.X°: ±.5° BREAK ALL SHARP EDGES .01 ALL DIMENSIONS IN INCHES UNLESS OTHERWISE STATED		TITLE: INSTALLATION AIR INLET DOUBLER R.H.					
	APPROVED BY:		DATE:	<table border="1"> <tr> <td>DRAWN BY: KML</td> <td>DATE: 11/10/96</td> <td>REV.: D</td> <td>SCALE: N/A</td> <td>SHEET: 1 OF 1</td> </tr> </table>	DRAWN BY: KML	DATE: 11/10/96	REV.: D	SCALE: N/A	SHEET: 1 OF 1
	DRAWN BY: KML	DATE: 11/10/96	REV.: D	SCALE: N/A	SHEET: 1 OF 1				
			<table border="1"> <tr> <td>APPLICATION: AS350/355</td> <td>DWG. NO.: 7-26-AS350</td> </tr> </table>	APPLICATION: AS350/355	DWG. NO.: 7-26-AS350				
APPLICATION: AS350/355	DWG. NO.: 7-26-AS350								

REVISION RECORD				
REV	DATE	DESCRIPTION OF CHANGE	APPVD. BY	REV. BY
A	9/1/14	CHANGED TITLE BLOCK AND REVISION BLOCK.		AJC
B	01/19/22	CLARIFY NOTE 11 TO ENSURE SEALANT IS APPLIED FOR CORROSION RESISTANCE PER ECO 1026.		SGB
C	08/04/23	INCORPORATED ECO 1226.		SGB

- NOTES:
- THIS INSTALLATION IS APPLICABLE TO AIRCRAFT WITH STRAP TYPE DOUBLERS AT THE SPLICE POINT BETWEEN THE FUSELAGE AND TAILBOOM.
 - REMOVE EXISTING STRAP. DISCARD.
 - REMOVE EXISTING BRACKET INSIDE AND DISCARD.
 - LOCATE EXISTING RIVET PATTERN AS SHOWN AND POSITION DOUBLER.
 - MARK AROUND DOUBLER, REMOVE DOUBLER AND REMOVE ANY RIVETS INSIDE MARKING.
 - RE-POSITION DOUBLER, BACK DRILL DOUBLER AND CLECO IN PLACE.
 - CUT OUT CENTER HOLE. TRIM DOUBLER AS NECESSARY TO FIT.
 - ALSO DRILL UPPER ANGLE P/N: 261096 AND DRILL IN LOWER ANGLE P/N: 261098
 - INSTALL NEW STRAP P/N 261512 IN SAME LOCATION OVER NEW DOUBLER.
 - TRIM LENGTHS AS NECESSARY.
 - SEAL DOUBLERS AND SCREENS WITH PRC AS NECESSARY FOR CORROSION PREVENTION.
 - RIVET LENGTHS MAYBE DETERMINED UPON INSTALLATION, INTERCHANEABILITY BETWEEN MS20470AD RIVET AND CR3234 OR CR3243 RIVETS IS APPROVED.

RIVET LEGEND:	
●	MS20470E-X RIVET ALT: MS20470D-X RIVET
⊙	MS20470AD5-X RIVET EXISTING
●	MS20470AD5-X RIVET
○	MS20470AD4-X RIVET
⊙	MS20426AD4-X RIVET

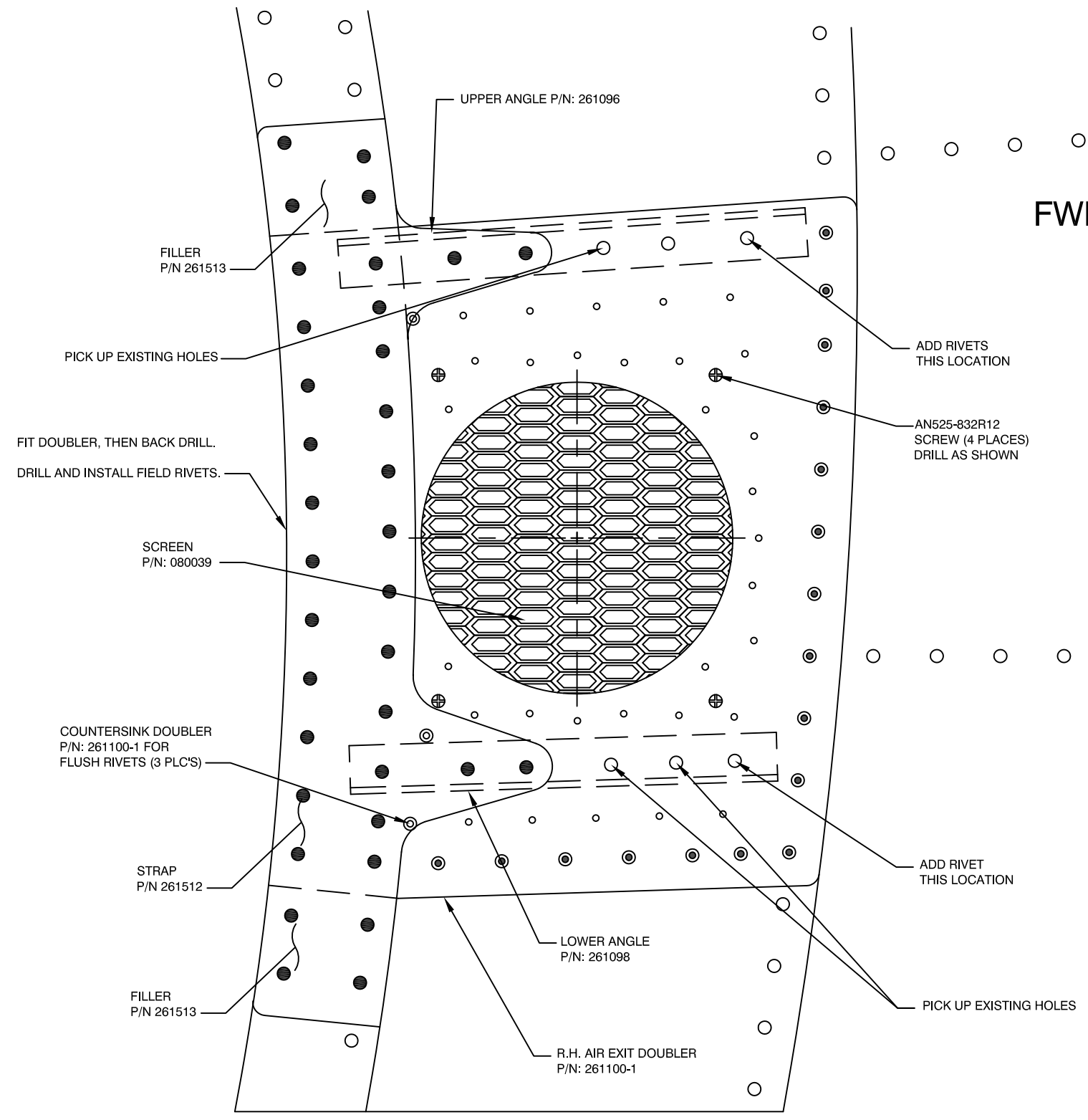

PROPRIETARY NOTICE TO ALL PERSONS RECEIVING THIS DOCUMENT THIS DOCUMENT AND INFORMATION OR TECHNICAL DATA AND DESIGNS CONTAINED HEREIN ARE PROPRIETARY DATA AND EXCLUSIVE PROPERTY OF RSG PRODUCTS INC. AND IS DELIVERED ON THE EXPRESS CONDITION THAT NEITHER THIS DOCUMENT NOR THE INFORMATION CONTAINED HEREIN SHALL BE DISCLOSED TO OTHERS, REPRODUCED IN WHOLE OR IN PART, OR USED FOR THE MANUFACTURE OR FABRICATION OF PARTS FOR ANYONE OTHER THAN RSG PRODUCTS INC. WITHOUT WRITTEN CONSENT AND AUTHORIZATION, AND THAT NO RIGHT IS GRANTED TO DISCLOSE OR SO USE ANY INFORMATION CONTAINED IN SAD DOCUMENT. THIS RESTRICTION DOES NOT LIMIT THE RIGHT TO USE INFORMATION OBTAINED FROM ANOTHER SOURCE.	NEXT ASSY.	TOLERANCES EXCEPT AS SHOWN
	APPROVED BY:	DATE:

RSG PRODUCTS INC.
A ROTORCRAFT SERVICES GROUP COMPANY

TITLE:
R.H. AIR EXIT DOUBLER INSTALL

DRAWN BY: MGV	DATE: 10/18/07	REV.: C	SCALE: N/A	SHEET: 1 OF 1
APPLICATION: AS350			DWG. NO.: 7-28-AS350	

NOTES:

1. THIS INSTALLATION IS APPLICABLE TO AIRCRAFT WITH STRAP TYPE DOUBLERS AT THE SPLICE POINT BETWEEN THE FUSELAGE AND TAILBOOM.
2. REMOVE EXISTING STRAP. DISCARD.
3. IF STROBE POWERPACK IS IN THE THREE O'CLOCK POSITION, RE-LOCATE TO THE 2 O'CLOCK POSITION.
4. LOCATE EXISTING RIVET PATTERN AS SHOWN AND POSITION DOUBLER.
5. MARK AROUND DOUBLER, REMOVE DOUBLER AND REMOVE ANY RIVETS INSIDE MARKING.
6. RE-POSITION DOUBLER, BACK DRILL DOUBLER AND CLECO IN PLACE.
7. CUT OUT CENTER HOLE. TRIM DOUBLER AS NECESSARY TO FIT.
8. ALSO DRILL UPPER ANGLE P/N: 261097 AND DRILL IN LOWER ANGLE P/N: 261098
9. INSTALL NEW STRAP P/N 261511 IN SAME LOCATION OVER NEW DOUBLER.
10. TRIM LENGTHS AS NECESSARY.
11. SEAL DOUBLERS AND SCREENS WITH PRC AS NECESSARY FOR CORROSION PREVENTION.
12. RIVET LENGTHS MAYBE DETERMINED UPON INSTALLATION, INTERCHANEABILITY BETWEEN MS20470AD RIVET AND CR3234 OR CR3243 RIVETS IS APPROVED.

RIVET LEGEND:

- MS20470E-X RIVET
ALT: MS20470D-X RIVET
- ⊙ MS20470AD5-X RIVET
- MS20470AD4-X RIVET
- MS20470AD4-X RIVET
- ⊙ MS20426AD4-X RIVET

BAGGAGE DOOR OPENING

FWD ←

REMOVE EXISTING ROW OF RIVETS UNDER DOUBLER VERTICALLY.
FIT DOUBLER, THEN BACK DRILL.
DRILL AND INSTALL FIELD RIVETS.

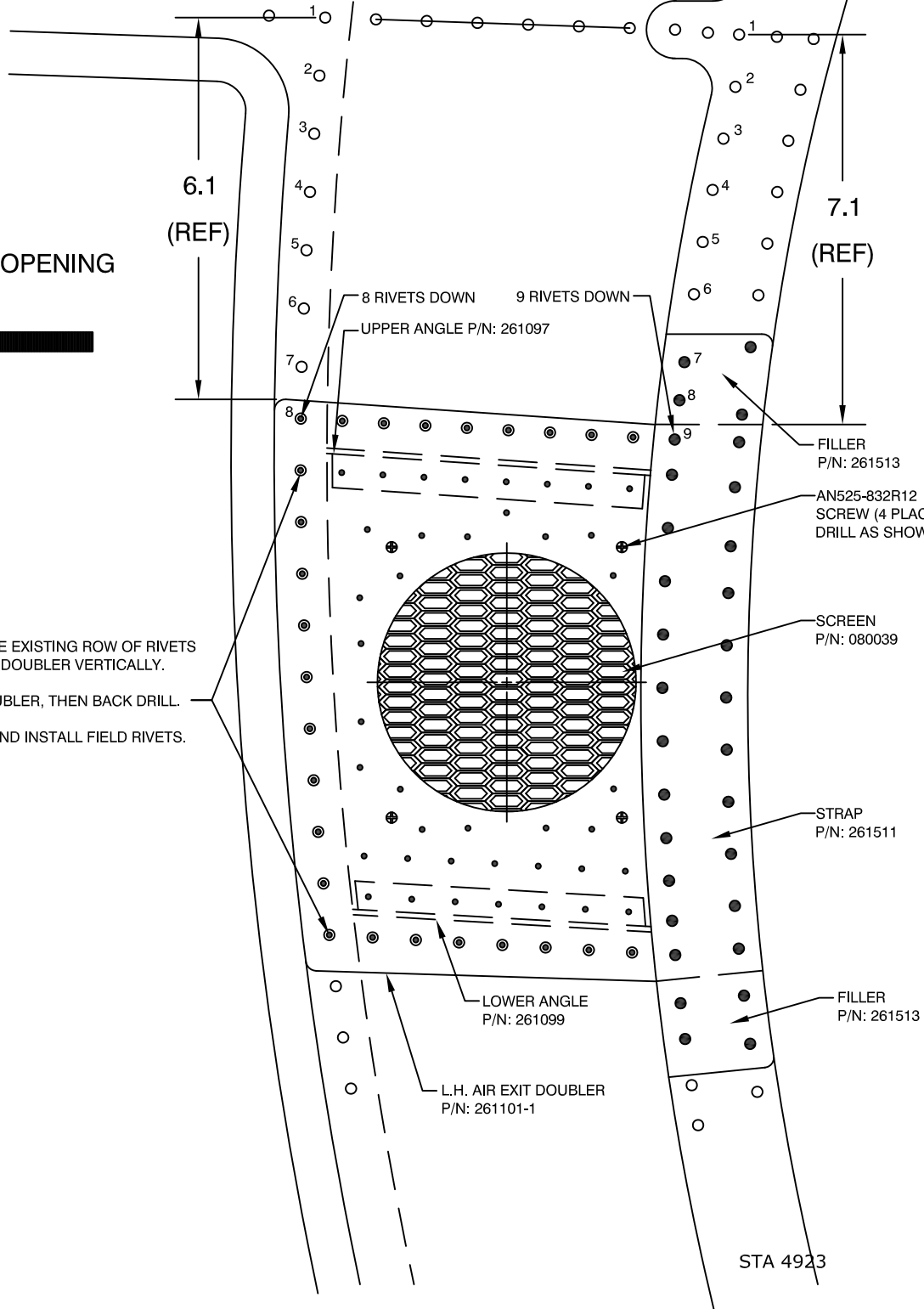

REVISION RECORD

REV	DATE	DESCRIPTION OF CHANGE	APPVD. BY	REV. BY
A	9/1/14	CHANGED TITLE BLOCK AND REVISION BLOCK.		AJC
B	01/19/22	CLARIFY NOTE 11 TO ENSURE SEALANT IS APPLIED FOR CORROSION PREVENTION PER ECO 1026.		SGB
C	08/04/23	INCORPORATED ECO 1228.		SGB

PROPRIETARY NOTICE

TO ALL PERSONS RECEIVING THIS DOCUMENT THIS DOCUMENT AND INFORMATION OR TECHNICAL DATA AND DESIGNS CONTAINED HEREIN ARE PROPRIETARY DATA AND EXCLUSIVE PROPERTY OF RSG PRODUCTS INC. AND IS DELIVERED ON THE EXPRESS CONDITION THAT NEITHER THIS DOCUMENT NOR THE INFORMATION CONTAINED HEREIN SHALL BE DISCLOSED TO OTHERS, REPRODUCED IN WHOLE OR IN PART, OR USED FOR THE MANUFACTURE OR FABRICATION OF PARTS FOR ANYONE OTHER THAN RSG PRODUCTS INC. WITHOUT WRITTEN CONSENT AND AUTHORIZATION, AND THAT NO RIGHT IS GRANTED TO DISCLOSE OR SO USE ANY INFORMATION CONTAINED IN SAD DOCUMENT. THIS RESTRICTION DOES NOT LIMIT THE RIGHT TO USE INFORMATION OBTAINED FROM ANOTHER SOURCE.

NEXT ASSY.

TOLERANCES EXCEPT AS SHOWN

.X: ±.1
.XX: ±.03
.XXX: ±.010
X.X": ±.5°
BREAK ALL SHARP EDGES .01
ALL DIMENSIONS IN INCHES UNLESS OTHERWISE STATED
DATE:

APPROVED BY:



TITLE:
L.H. AIR EXIT DOUBLER INSTALL

DRAWN BY: MGV DATE: 10/18/07 REV.: C SCALE: N/A SHEET: 1 OF 1

APPLICATION: AS350 DWG. NO.: 7-29-AS350

Step 7

Installation of Forward Evaporator

Installation of Forward Evaporator

STEP	PROCEDURE	MECH	INSP
7.1	Relocate NR digital indicator. Higher 12” min., and aft of pitot static lines, using assisting hardware. See note on drawing 4-21-AS350.		
7.2	Relocate warning horn up and forward as required.		
7.3	Position forward evaporator assembly, P/N 560025-O, as shown in drawing 4-21-AS350. Mark rivets to be drilled out and existing bolts that will be used to mount evaporator. Also mark location on inboard forward mount hole on floor as shown in note on drawing 4-21-AS350.		
7.4	Remove and drill out rivets and marked hole. Install nut plate on evaporator.		
7.5	Position doublers P/N 260373 and P/N 260373-1 as shown in drawing 4-21-AS350, drill and install as shown. Cut out center. Line hole with Caterpillar, bond to edge of metal.		
7.6	Do not install evaporator until Freon lines are connected.		
7.7	Install drain line from the evaporator out through the cabin floor. The existing hole normally found in the aircraft skin (right forward side) can be utilized. Cutting of the aircraft skin will not usually be required. “IF” no vacant hole is found, or more direct routing is required to allow for appropriate drainage, locate and drill a hole according to the detail “A” on drawing 4-21-AS350. Install grommet. Secure drain line and cut off at a negative angle.		
7.8	When connecting Freon lines, make sure you install sensing bulb on #10 line. Wrap cork tape around fittings. See drawing 4-21 AS350 “Expansion Valve Detail”. After all lines are attached install Fwd Evaporator with hardware per drawing 4-21-AS350.		

Air Distribution

STEP	PROCEDURE	MECH	INSP
7.9	<p><u>AIR DISTRIBUTION:</u></p> <p>Drawings 5-26-AS350, 5-10-AS350 and 5-21-AS350</p> <p>For config. -01: Locate the air outlets on the left and right underside of panel support bar as shown in drawing 5-26-AS350.</p> <p>For config. -02: Locate the air outlets on the left and right upper side of panel as shown in drawing 5-26-AS350.</p>		
7.10	<p>For config. -01: Install 2 each Air Outlet Assembly PN: 510259-3 per drawing 5-26-AS350 View A-A, sheet 1 of 3.</p> <p>For config. -02: Install 2 each Air Outlet Assembly PN's: 520156HP-01 and 520157HP-01 per drawing 5-26-AS350 sheet 2 of 3.</p>		
7.11	<p>After installation of air outlet assemblies, attach 2 ½" flex hoses from the assemblies to the evaporator. The hose to the right hand air outlet is very straight forward.</p> <p>The installation of the left side flexible air hose can vary according to the avionics package installed. In some aircraft, it is quite simple to route the hose aft of the radio stack through existing holes in the vertical sheet metal aircraft parts. In other aircraft, due to the type of radios installed, it will be necessary to cut a round hole in the vertical aircraft sheet metal components and route the flex hose through this hole after lining the edges with Caterpillar for protection against chafing of the hose.</p>		

NOTES:
 1. INSULATE EXPANSION VALVE WITH CORK TAPE.
 RELOCATE WARNING HORN UP & FORWARD, AS REQUIRED.
 NOTE B3 ONLY:
 RELOCATE NR DIGITAL INDICATOR MOUNTED NEAR FLOOR, ON RIGHT SIDE OF CONSOLE PANEL UP 12.0" MIN. FROM FLOOR AND AFT OF PITOT STATIC LINES USING EXISTING HARDWARE. REROUTE NR WIRE TO ACCOMMODATE NEW NR LOCATION.
 EXTREMELY IMPORTANT:
 FAILURE TO SECURE EXPANSION VALVE SENSING BULB TIGHTLY, TO THE RETURN LINE HOSE FITTING (#10) WITH A STAINLESS STEEL CLAMP (AND INSULATE SENSING BULB & LINE) WILL DRAMATICALLY DECREASE THE PERFORMANCE OF THE AFT EVAPORATOR (NOT FORWARD).

REVISION RECORD				
REV	DATE	DESCRIPTION OF CHANGE	APPVD. BY	REV. BY
F	01/03/07	CORRECTED FWD EVAP PN: 560025-1-O TO 560025-O. REVISED TITLE BLOCK.	IFS	JTYE
G	9/1/14	CHANGED TITLE BLOCK AND REVISION BLOCK.		AJC
H	01/19/22	ADDED CONFIGURATION VIEW PER ECO 0988. REMOVED ALT. P/N. CHANGED GROMMET IN NOTE FROM -135 TO -123 & LENGTHEN DRAIN HOSE FROM 1.00 TO 6.00 ON BOTH -01 & -02 CONFIG. PER ECO 1060. REPLACED CLAMP P/N 060037 WITH CLAMP P/N 6143114 PER ECO 1063.		SGB
J	08/04/23	INCORPORATED ECO'S 1183, 1185 AND 1224.		SGB

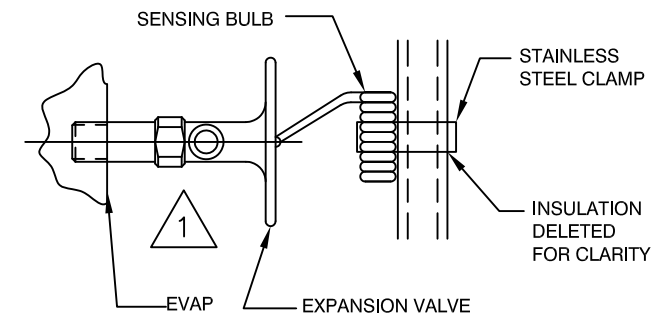
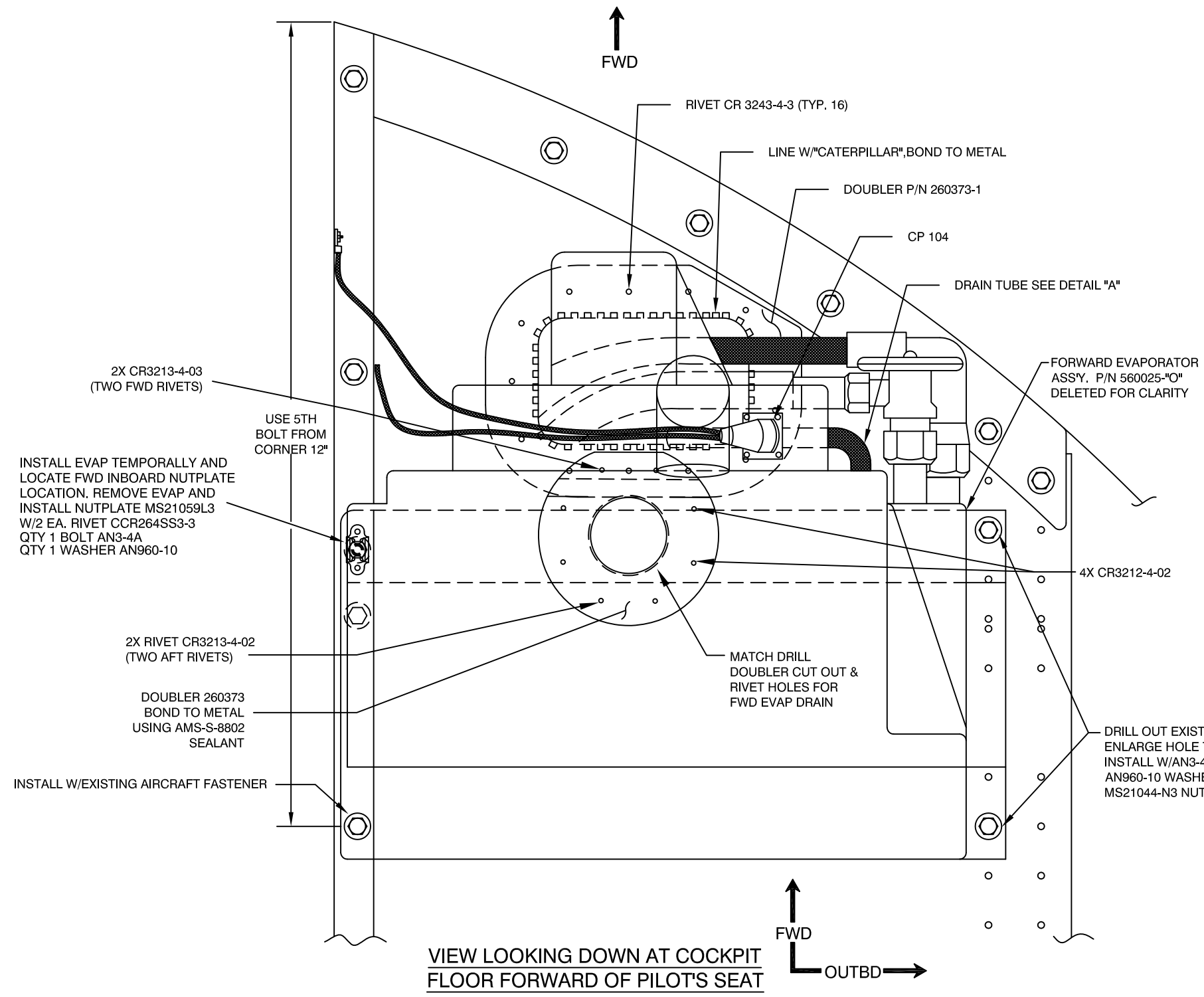

VIEW LOOKING DOWN AT COCKPIT FLOOR FORWARD OF PILOT'S SEAT

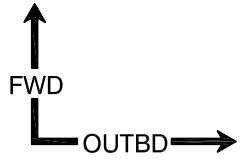

PROPRIETARY NOTICE TO ALL PERSONS RECEIVING THIS DOCUMENT THIS DOCUMENT AND INFORMATION OR TECHNICAL DATA AND DESIGNS CONTAINED HEREIN ARE PROPRIETARY DATA AND EXCLUSIVE PROPERTY OF RSG PRODUCTS INC. AND IS DELIVERED ON THE EXPRESS CONDITION THAT NEITHER THIS DOCUMENT NOR THE INFORMATION CONTAINED HEREIN SHALL BE DISCLOSED TO OTHERS, REPRODUCED IN WHOLE OR IN PART, OR USED FOR THE MANUFACTURE OR FABRICATION OF PARTS FOR ANYONE OTHER THAN RSG PRODUCTS INC. WITHOUT WRITTEN CONSENT AND AUTHORIZATION, AND THAT NO RIGHT IS GRANTED TO DISCLOSE OR SO USE ANY INFORMATION CONTAINED IN SAD DOCUMENT. THIS RESTRICTION DOES NOT LIMIT THE RIGHT TO USE INFORMATION OBTAINED FROM ANOTHER SOURCE.	NEXT ASSY.	TOLERANCES EXCEPT AS SHOWN						
		.X: ±.1 .XX: ±.03 .XXX: ±.010 X.X": ±.5° BREAK ALL SHARP EDGES .01 ALL DIMENSIONS IN INCHES UNLESS OTHERWISE STATED		TITLE: FORWARD EVAPORATOR INSTALL				
	APPROVED BY:	DATE:		DRAWN BY: JEL	DATE: 06/20/85	REV.: J	SCALE: N/A	SHEET: 1 OF 2
				APPLICATION: AS350	DWG. NO.: 4-21-AS350			

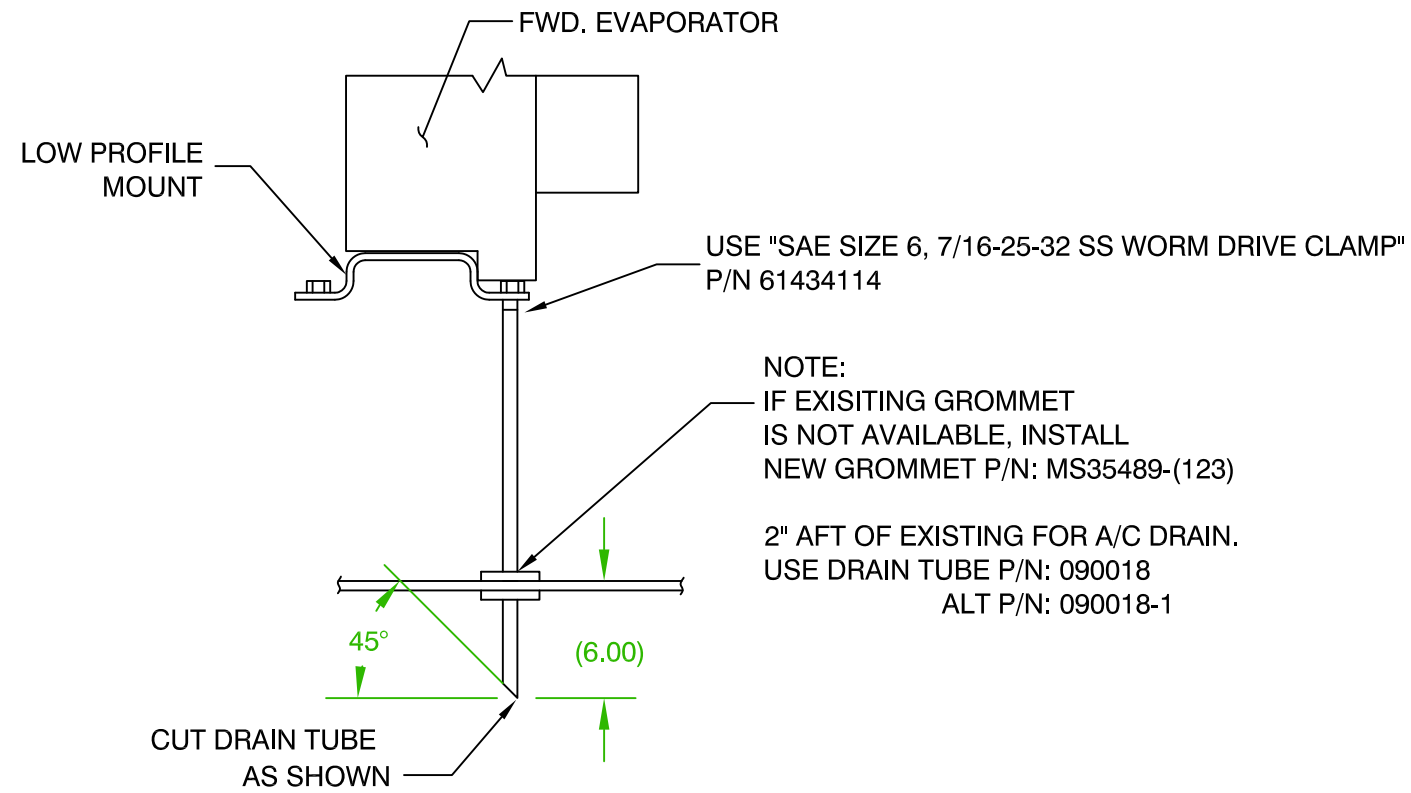

DETAIL A
FORWARD

-01, FWD. EVAP. ASSY.
(low profile config. used for aircraft w/ wipers)

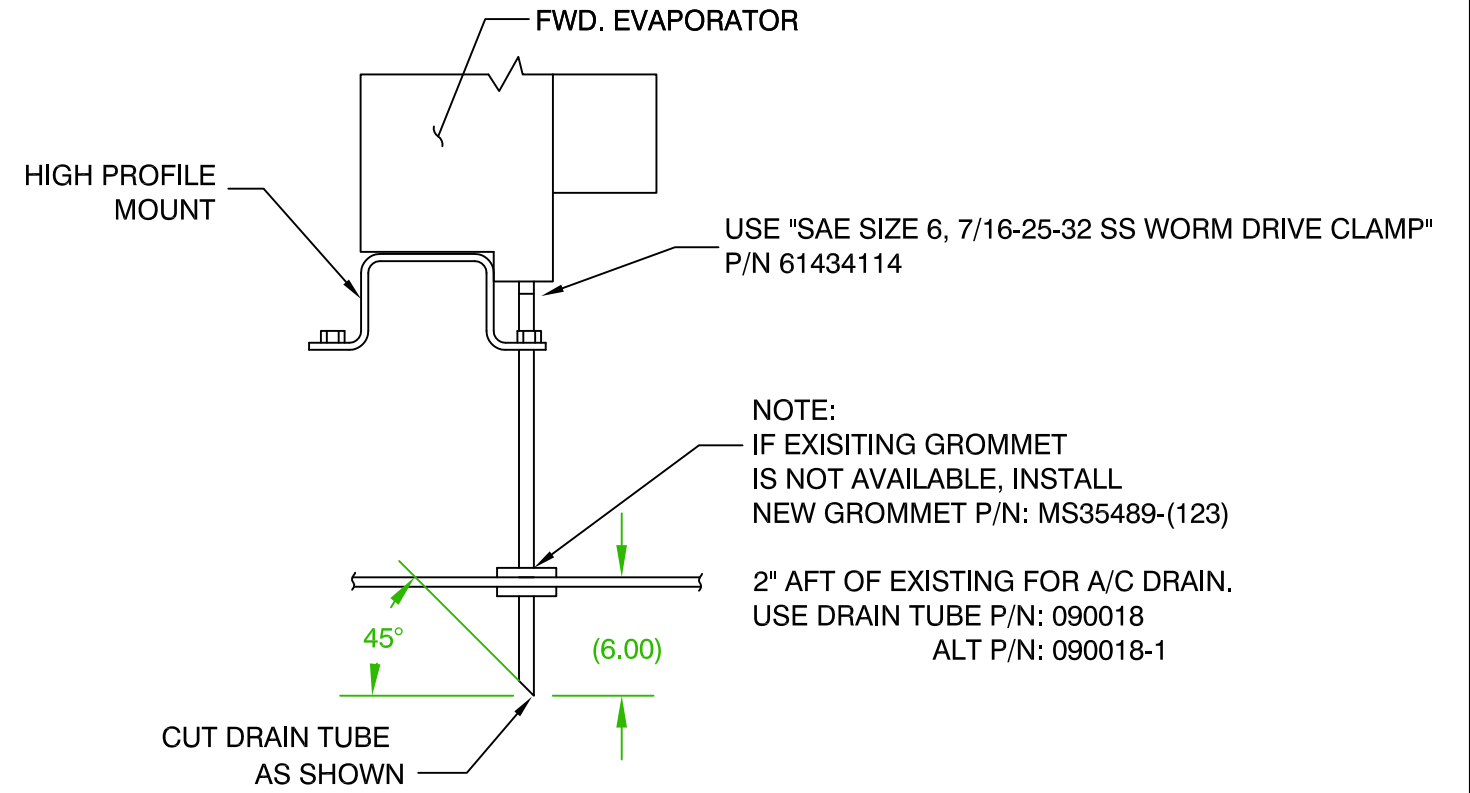

DETAIL A
FORWARD

-02, FWD. EVAP. ASSY.
(high profile config. used for aircraft w/o wipers)



TITLE:
FORWARD EVAPORATOR INSTALL

DRAWN BY: JEL	DATE: 06/20/85	REV.: J	SCALE: N/A	SHEET: 2 OF 2
------------------	-------------------	------------	---------------	------------------

APPLICATION: AS350	DWG. NO.: 4-21-AS350
-----------------------	-------------------------



ENGINEERING CHANGE ORDER

ECO No.	1259	SHT 1 OF 1
DWG No.	4-21-AS350	REV J
DWG No.		REV
DWG No.		REV
REF. STC No.	SH3509SW	

CHANGE CLASS:
 RECORD CHG. PARTS NOT AFFECTED NON-INTERCHANGEABLE PARTS
 INTERCHANGEABLE PARTS OTHER _____

EXISTING/IN-WORK STOCK DISPOSITION:
 RECORD CHG. PARTS NOT AFFECTED RE-WORK EXISTING STOCK
 SCRAP EXISTING STOCK OTHER BREAK IN AT NEXT BUILD

EFFECTIVITY:
 ALL UNITS THIS CUSTOMER LIMITED UNITS SPECIFIED
 ALL UNITS MFG'D AFTER THIS DATE OTHER ALL UNITS

DESCRIPTION OF CHANGE: ON SHEET 2: CHANGE REFERENCE FOR GROMMET FROM "(123)" TO "(72)"

WAS:

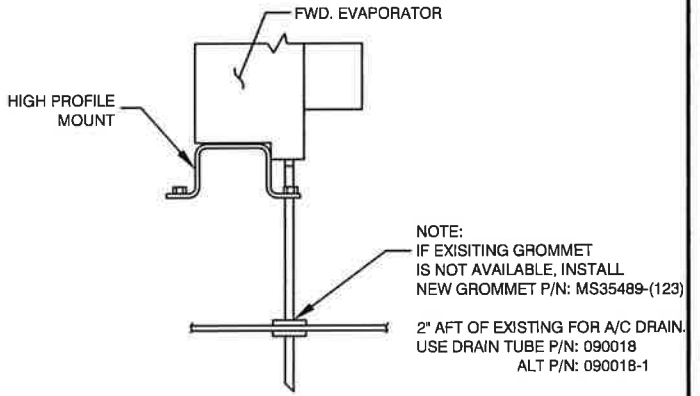
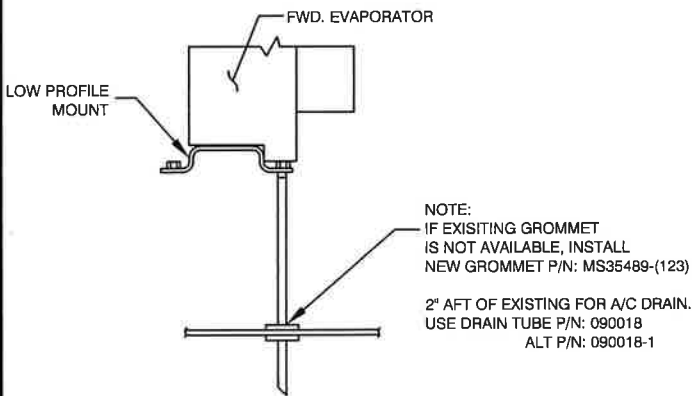

IS:

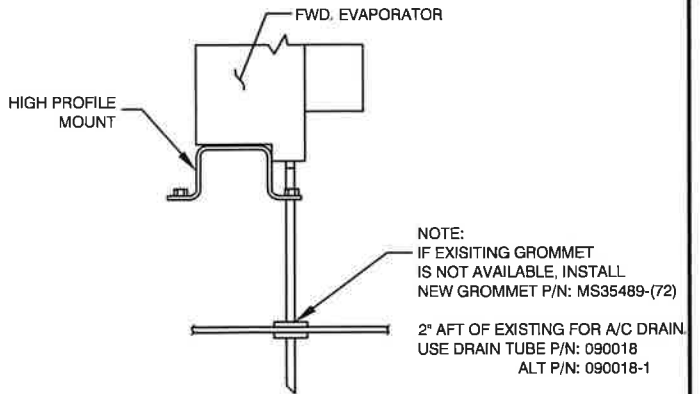
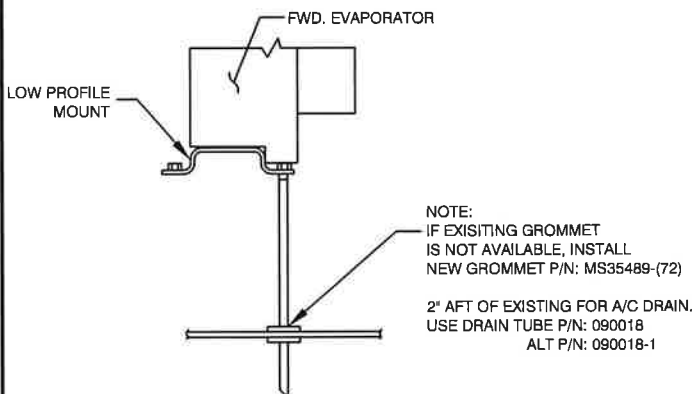

REMARKS:
MINOR CHANGES FOR PRODUCT IMPROVEMENT.

ENGINEERING REVIEW BOARD		
SIGNATURE	STAMP	DATE
	MRB04	9/25/2023
	QA22	10/2/2023
	P016	10/16/2023
INCORPORATION STATUS		
<input type="checkbox"/> IMMEDIATE <input checked="" type="checkbox"/> OUTSTANDING		



ENGINEERING
CHANGE
ORDER

ECO No.	1282	SHT 1 OF 1
DWG No.	4-21-AS350	REV J
DWG No.		REV
DWG No.		REV
REF. STC No.	SH3509SW	

CHANGE CLASS:

- RECORD CHG. PARTS NOT AFFECTED NON-INTERCHANGEABLE PARTS
 INTERCHANGEABLE PARTS OTHER _____

EXISTING/IN-WORK STOCK DISPOSITION:

- RECORD CHG. PARTS NOT AFFECTED RE-WORK EXISTING STOCK
 SCRAP EXISTING STOCK OTHER BREAK IN AT NEXT BUILD

EFFECTIVITY:

- ALL UNITS THIS CUSTOMER LIMITED UNITS SPECIFIED
 ALL UNITS MFG'D AFTER THIS DATE OTHER ALL UNITS

DESCRIPTION OF CHANGE: ADD ALT. RIGID DRAIN TUBE ASSY P/N TO SHEET 2 OF 2.

WAS:

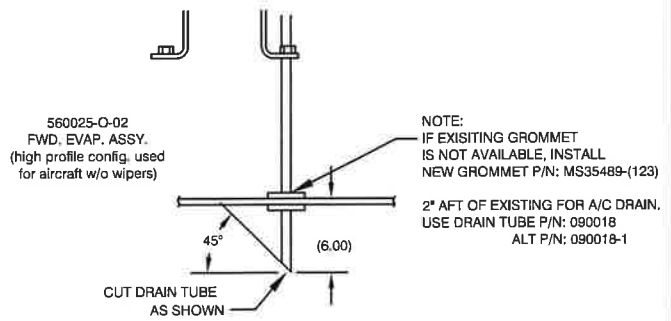
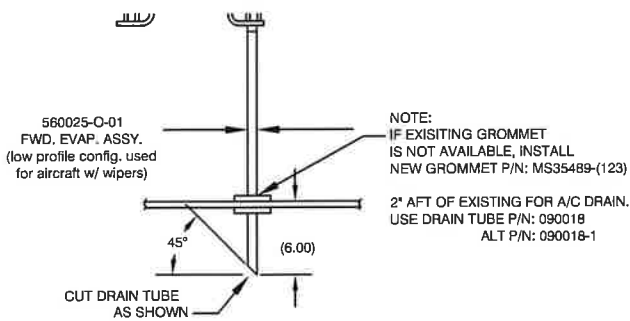

IS:

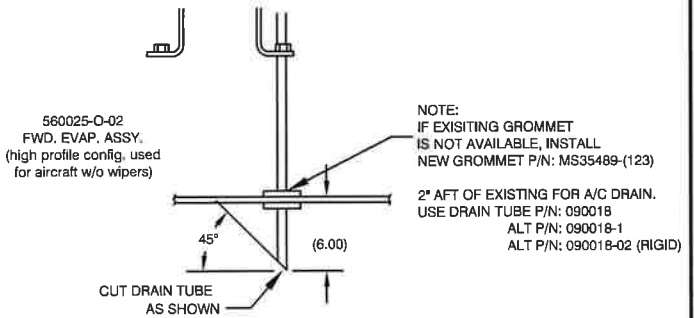
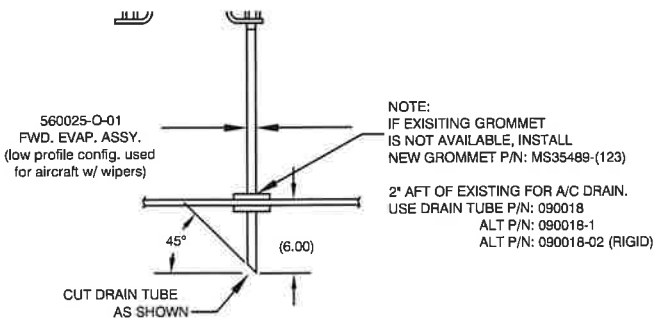

REMARKS: MINOR CHANGE.
ADDED ALT. P/N.

ENGINEERING REVIEW BOARD		
SIGNATURE	STAMP	DATE
	MRB04	2/12/2024
	QA22	2/12/2024
	P016	2/14/2024
INCORPORATION STATUS		
<input type="checkbox"/> IMMEDIATE <input checked="" type="checkbox"/> OUTSTANDING		

NOTES:

▷ ATTACH 2.5" DIAMETER DUCT TO ADAPTER AND SECURE WITH 2.5" BAND CLAMP. QTY. 1 EA. FOR L.H. AND R.H.

REVISION RECORD				
REV	DATE	DESCRIPTION OF CHANGE	APPVD. BY	REV. BY
A	03/12/13	CHANGE TITLE BLOCK AND REVISION BLOCK. ADDED -02 AIR OUTLET INSTALL AND 540044-8-02 SWITCH PANEL INSTALL PER ECO # 0642 & 0716		AJC
B	01/19/22	CHANGED VIEW TO ADD ALTERNATE LOCATION OF P/N: 540044-8-02 PER ECO 0957.		SGB
C	08/04/23	INCORPORATED ECO'S 1181 AND 1196.		SGB

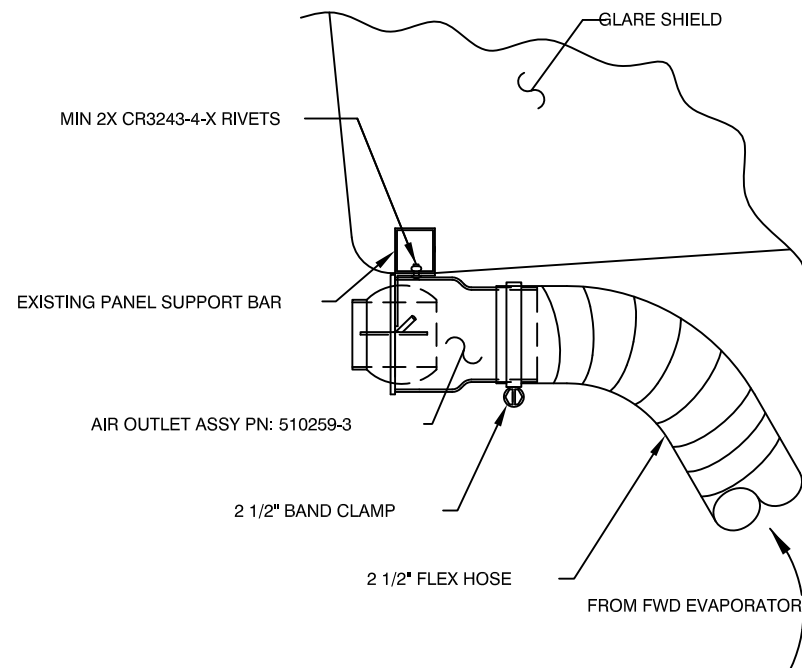
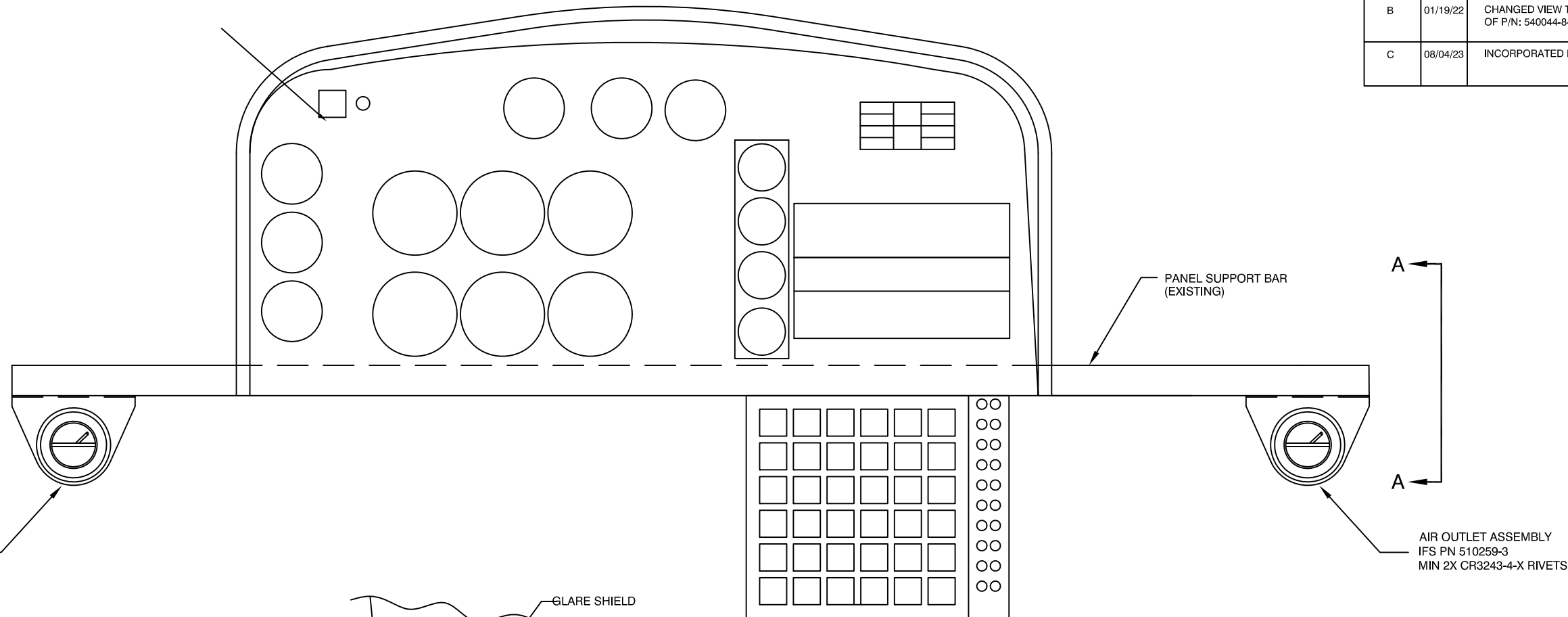

VIEW A-A

-01 AIR OUTLET INSTALLATION

<p>PROPRIETARY NOTICE</p> <p>TO ALL PERSONS RECEIVING THIS DOCUMENT THIS DOCUMENT AND INFORMATION OR TECHNICAL DATA AND DESIGNS CONTAINED HEREIN ARE PROPRIETARY DATA AND EXCLUSIVE PROPERTY OF RSG PRODUCTS INC. AND IS DELIVERED ON THE EXPRESS CONDITION THAT NEITHER THIS DOCUMENT NOR THE INFORMATION CONTAINED HEREIN SHALL BE DISCLOSED TO OTHERS, REPRODUCED IN WHOLE OR IN PART, OR USED FOR THE MANUFACTURE OR FABRICATION OF PARTS FOR ANYONE OTHER THAN RSG PRODUCTS INC. WITHOUT WRITTEN CONSENT AND AUTHORIZATION, AND THAT NO RIGHT IS GRANTED TO DISCLOSE OR SO USE ANY INFORMATION CONTAINED IN SAD DOCUMENT. THIS RESTRICTION DOES NOT LIMIT THE RIGHT TO USE INFORMATION OBTAINED FROM ANOTHER SOURCE.</p>	NEXT ASSY.	TOLERANCES EXCEPT AS SHOWN			
	APPROVED BY:	.X: ±.1 .XX: ±.03 .XXX: ±.010 X.X": ±.5° BREAK ALL SHARP EDGES .01 ALL DIMENSIONS IN INCHES UNLESS OTHERWISE STATED		TITLE: AIR DISTRIBUTION	
DRAWN BY: JTYE		DATE: 06/30/08	REV.: C	SCALE: N/A	SHEET: 1 OF 3
APPLICATION: AS350				DWG. NO.: 5-26-AS350	

8 7 6 5 4 3 2 1

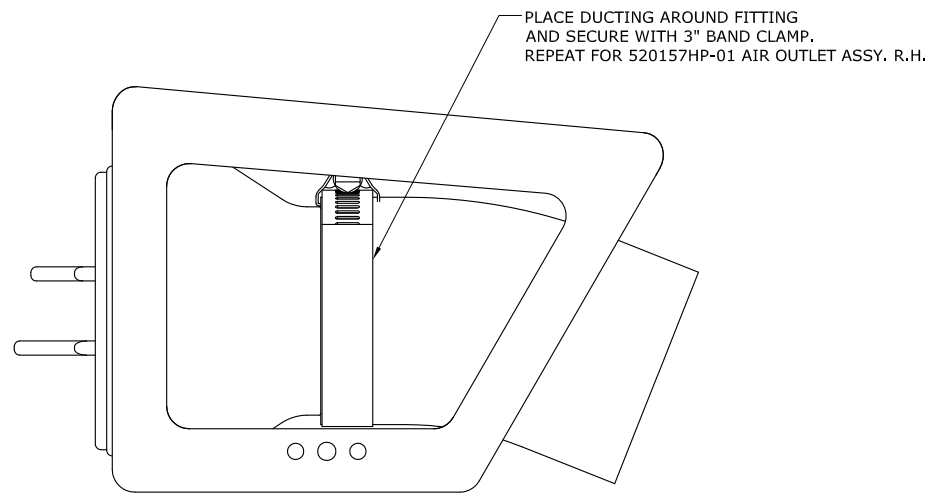

AIR OUTLET ASSY. L.H.
 P/N: 520156HP-01
 PLACE AIR OUTLET FLUSH WITH GLARE SHIELD.
 SLIDE AIR OUTLET DOWN ONTO Z MOUNT.
 MATCH DRILL NUTPLATE HOLE TO GLARE SHIELD.
 ATTACH USING 1X AN525-832R8.

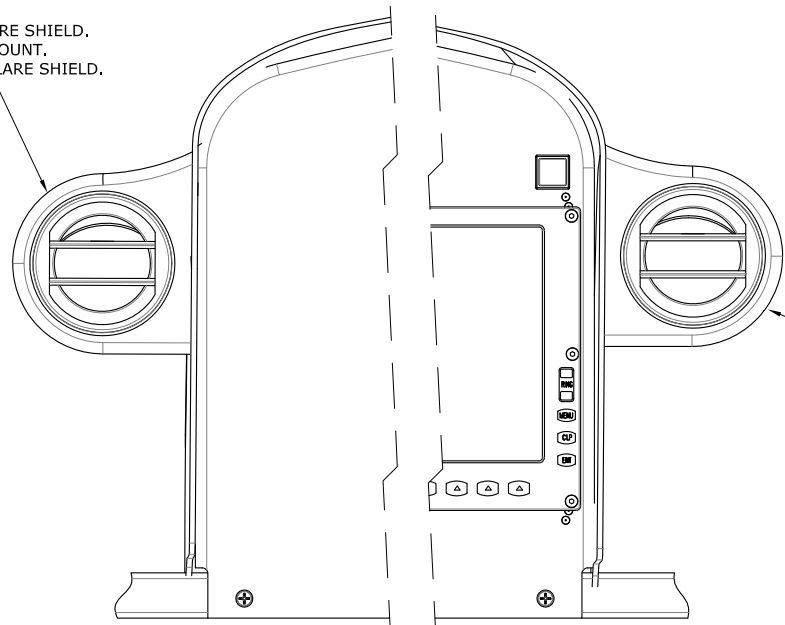

VENT MOUNT P/N: 261335HP-01
 LOCATE AS DIMENSIONED.
 MATCH DRILL 2X Ø.177 THRU.
 ATTACH USING 2X AN525-832R8
 AND 2X MS21042L08.
 REPEAT FOR RIGHT SIDE OF GLARE SHIELD.

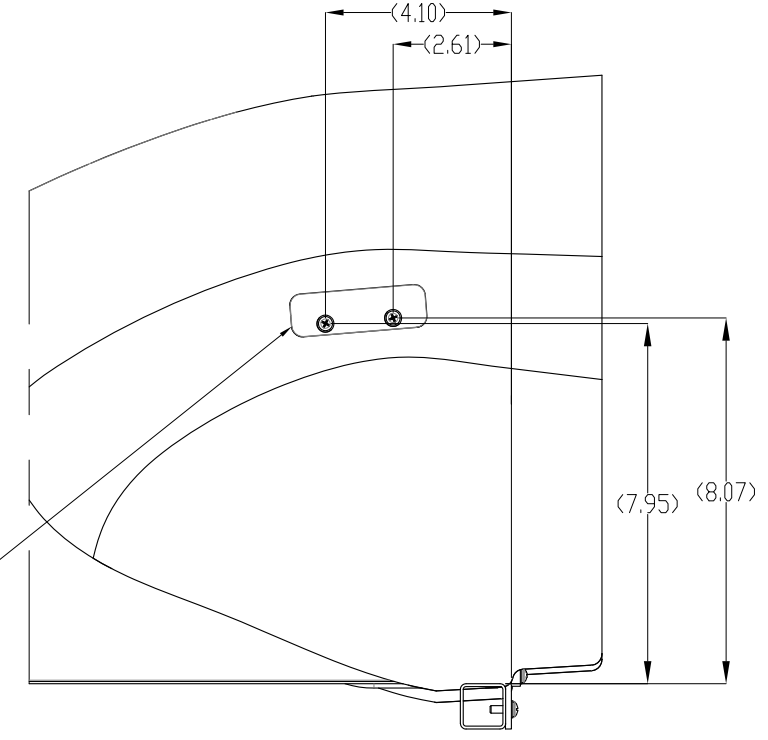

AIR OUTLET ASSY. R.H.
 P/N: 520157HP-01
 PLACE AIR OUTLET FLUSH WITH GLARE SHIELD.
 SLIDE AIR OUTLET DOWN ONTO Z MOUNT.
 MATCH DRILL NUTPLATE HOLE TO GLARE SHIELD.
 ATTACH USING 1X AN525-832R8.

SECTION B-B
 GLARE SHIELD HOLE REFERENCE
 AIR VENT REMOVED FOR CLARITY

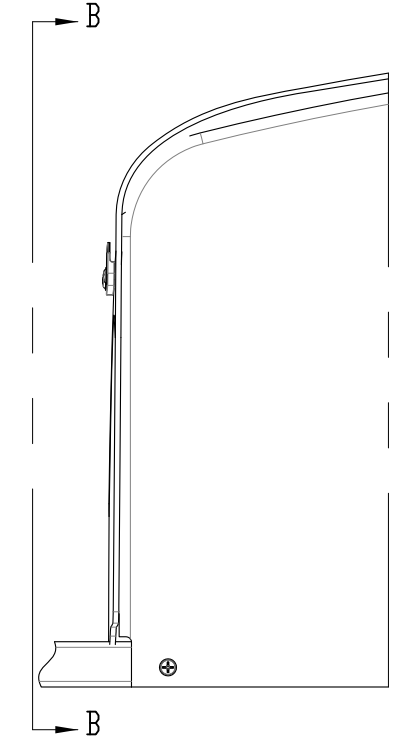

-02 AIR OUTLET INSTALLATION, ALT. ASSY.



TITLE: AIR DISTRIBUTION				
DRAWN BY: JT YE	DATE: 6/30/08	REV.: C	SCALE: N/A	SHEET: 2 OF 3
APPLICATION: AS 350			DWG. NO.: 5-26-AS350	

8 7 6 5 4 3 2 1

8 7 6 5 4 3 2 1

D
C
B
A

LOCATE 540044-8-02 ANYWHERE ON INSTRUMENT PANEL OR CENTER PEDESTAL. MATCH CUTOUT TO SWITCH ASSEMBLY. INSTALL 2X DZUS RAILS P/N: 261348HP USING 6X RIVET P/N MS20426AD4-7. COUNTERSINK AND TOUCH UP PAINT AS REQUIRED. FASTEN SWITCH PANEL TO DZUS RAILS.

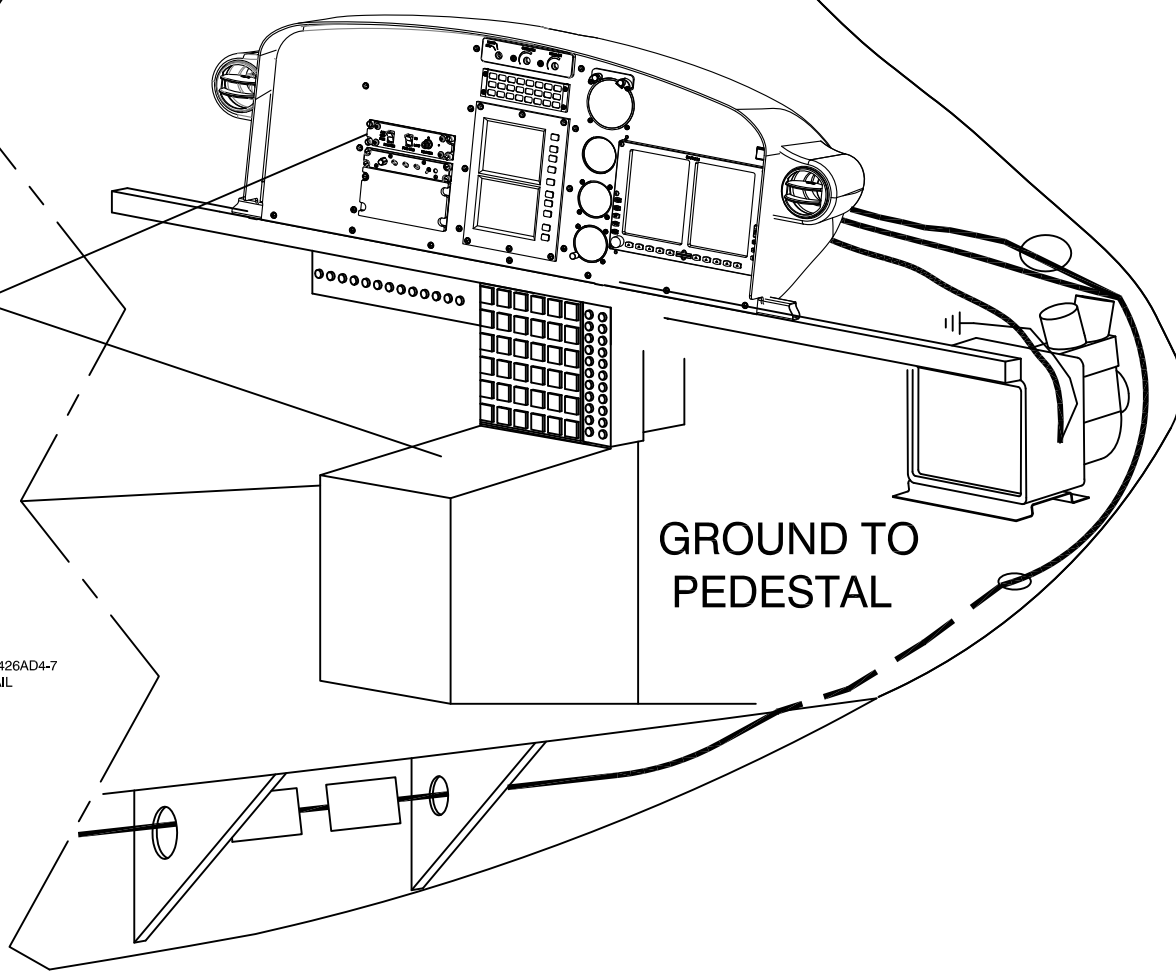
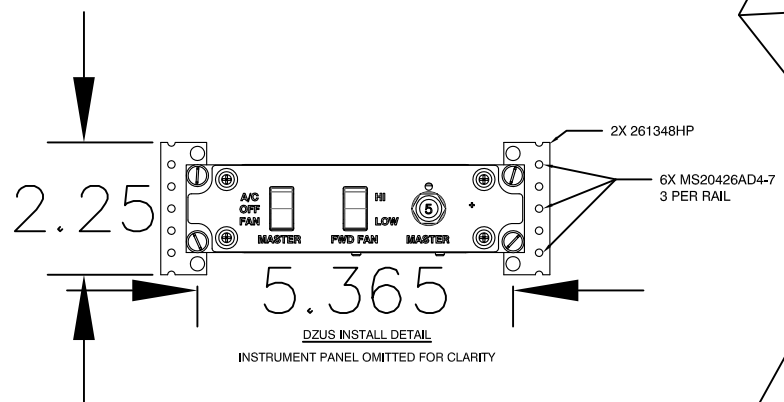

540044-8-02 SWITCH PANEL INSTALL

For installation of 540044-8-02: If AC control panel is relocated from the I-panel to the console then the dimming wire must also be relocated. Relocate wire IFS111C20 from the 131L1 Module to 133L3M1-E or any available location within the M1 module. Add a resistor (suggested value 3.3k ohm 1/2 W) as required to achieve proper lighting balance.



TITLE: AIR DISTRIBUTION				
DRAWN BY: JTYE	DATE: 6/30/08	REV.: C	SCALE: N/A	SHEET: 3 OF 3
APPLICATION: AS 350			DWG. NO.: 5-26-AS350	

8 7 6 5 4 3 2 1

8 7 6 5 4 3 2 1

REVISION RECORD				
REV	DATE	DESCRIPTION OF CHANGE	APPVD. BY	REV. BY
F	9/1/14	CHANGED TITLE BLOCK AND REVISION BLOCK, ADDED -02 VIEWS AND INSTRUCTIONS PER ECO # 0709.		AJC
G	01/19/22	ADDED NOTE TO TOP DETAIL VIEW C. REMOVED BOTTOM DETAIL C VIEW. MODIFY NOTE TO VIEW LOCATED IN ZN B1. CHANGED SCREW SIZE ON NOTE IN VIEW B-B PER ECO's 0817 & 0980.		SGB
H	08/04/23	INCORPORATED ECO 1177.		SGB

DETAIL D
ACCEPTABLE TO ELONGATE OPENING TO CENTER PEDESTAL UP TO 1" FOR PROPER FITTING OF FWD EVAP DUCT.

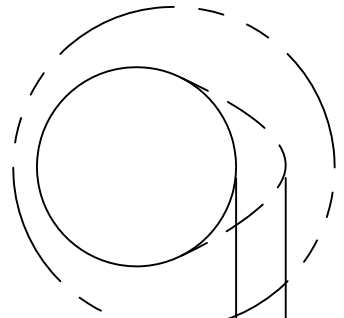

(1.00)

AIR DUCT CLOSURE ASSY PN 510092
REMOVE & DISCARD EXISTING FRESH AIR INLET INSTALL CLOSURE ASSY USING EXISTING HARDWARE

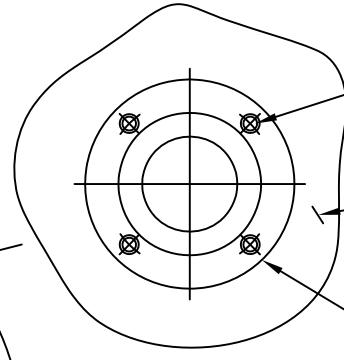
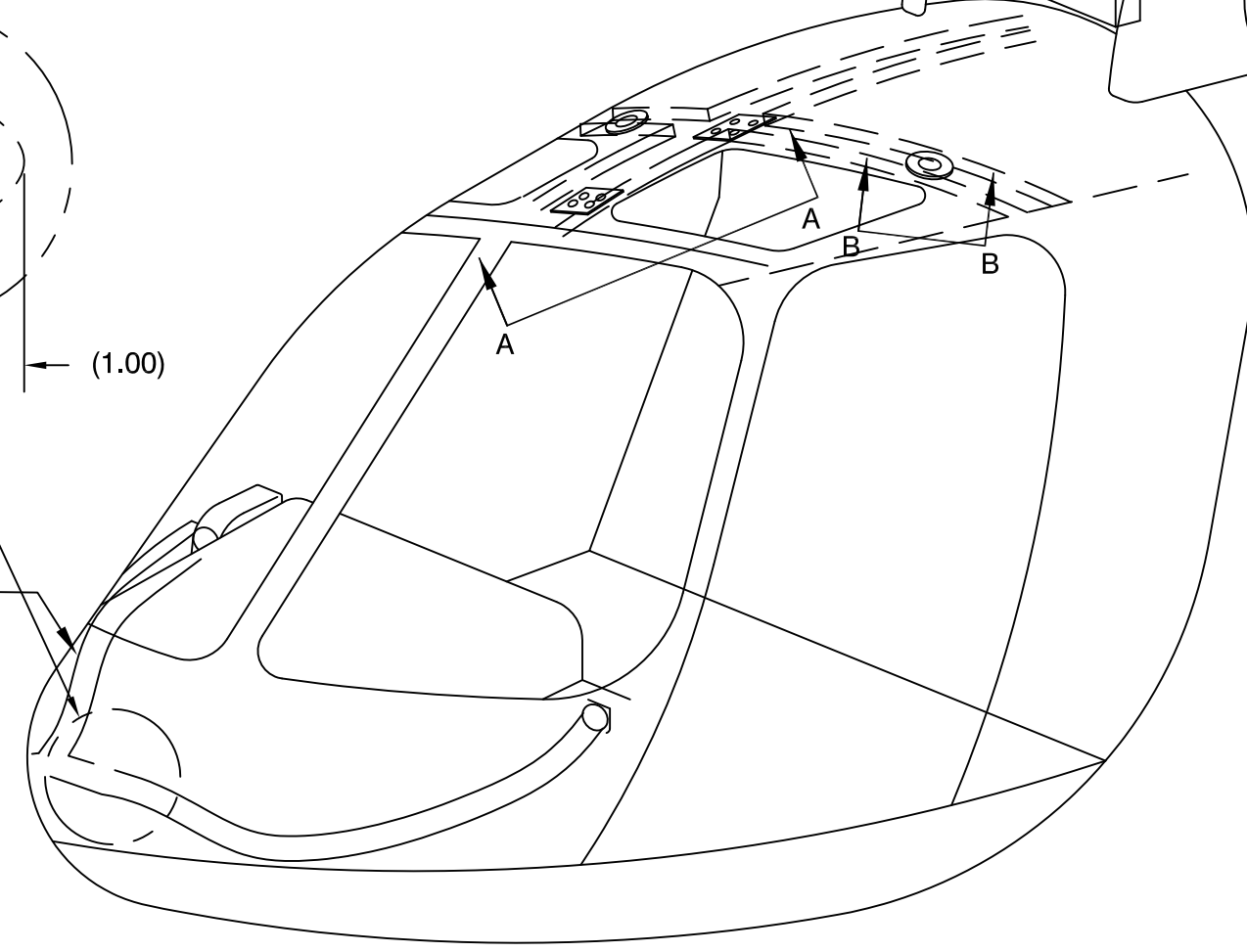

VIEW B-B

TAP EXISTING AIR OUTLET MOUNTS TO 8-32 UNF
INSTALL WEMAC USING SCREWS MS 24693-S53 (4)
SNAP ON DECOR RING NO 7194-1

TRIM HEADLINER AND CABIN STRUCTURE TO FIT WEMAC

ROTATE NEW WEMAC 90°
MATCH DRILL NEW HOLES (COUNTERSINK)
IN WEMAC TO MATCH AIR FRAME

WEMAC NO 2368-503 (CLEAR)
NOTE: APPLIES TO AIRCRAFT
W/SMALL ADH AIR OUTLETS

2 1/2" FLEX DUCT

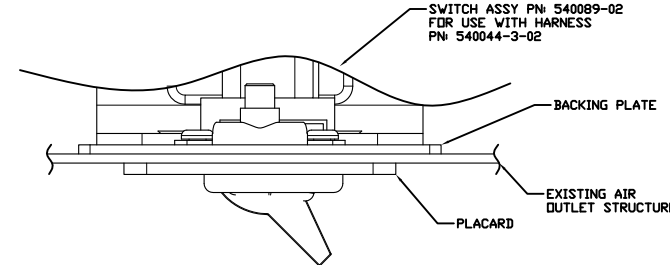

VIEW X-X

REMOVE SWITCH FROM REAR OF SWITCH ASSEMBLY
PRIOR TO INSTALL. MATCH DRILL SWITCH CUTOUT
AND SCREW HOLES. TRIM AS REQUIRED.

540089-02

SWITCH ASSY PN 540089-02
FOR USE WITH HARNESS
PN 540044-3-02

BACKING PLATE

EXISTING AIR
OUTLET STRUCTURE

PLACARD

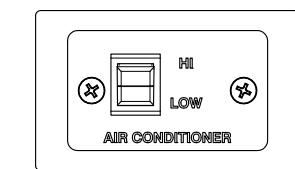
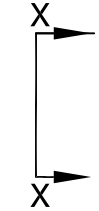

540089-02

LOCATE SWITCH ASSY AFT & LEFT
OR RIGHT OF
EXISTING AIR OUTLETS FOR 1995
MODELS & ON

<p>PROPRIETARY NOTICE</p> <p>TO ALL PERSONS RECEIVING THIS DOCUMENT THIS DOCUMENT AND INFORMATION OR TECHNICAL DATA AND DESIGNS CONTAINED HEREIN ARE PROPRIETARY DATA AND EXCLUSIVE PROPERTY OF RSG PRODUCTS INC. AND IS DELIVERED ON THE EXPRESS CONDITION THAT NEITHER THIS DOCUMENT NOR THE INFORMATION CONTAINED HEREIN SHALL BE DISCLOSED TO OTHERS, REPRODUCED IN WHOLE OR IN PART, OR USED FOR THE MANUFACTURE OR FABRICATION OF PARTS FOR ANYONE OTHER THAN RSG PRODUCTS INC. WITHOUT WRITTEN CONSENT AND AUTHORIZATION, AND THAT NO RIGHT IS GRANTED TO DISCLOSE OR SO USE ANY INFORMATION CONTAINED IN SAID DOCUMENT. THIS RESTRICTION DOES NOT LIMIT THE RIGHT TO USE INFORMATION OBTAINED FROM ANOTHER SOURCE.</p>	<p>NEXT ASSY.</p>	<p>TOLERANCES EXCEPT AS SHOWN</p> <p>.X: ±.1 .XX: ±.03 .XXX: ±.010 X.X": ±.5° BREAK ALL SHARP EDGES .01 ALL DIMENSIONS IN INCHES UNLESS OTHERWISE STATED</p>			
	<p>APPROVED BY:</p>	<p>DATE:</p>		<p>TITLE:</p> <p>AIR CONDITIONING OVERVIEW</p>	
	<p>DRAWN BY:</p> <p>JM</p>	<p>DATE:</p> <p>06/20/85</p>	<p>REV.:</p> <p>H</p>	<p>SCALE:</p> <p>N/A</p>	<p>SHEET:</p> <p>1 OF 1</p>
	<p>APPLICATION:</p> <p>AS350</p>	<p>DWG. NO.:</p> <p>5-10-AS350</p>			

8 7 6 5 4 3 2 1

REVISION RECORD				
REV	DATE	DESCRIPTION OF CHANGE	APPVD. BY	REV. BY
F	01/03/07	CORRECTED PN'S, ADDED PHOTO AND TRIMMING NOTATION. REVISED TITLE BLOCK.		JTYE
G	9/1/14	CHANGED TITLE BLOCK AND REVISION BLOCK.		AJC
H	08/04/23	INCORPORATED ECO'S 1078 AND 1116.		SGB

NOTE:
 STEPS #1 & #2 PERTAIN TO BOTH DOUBLER INSTALLATIONS
 INTERCHANGEABILITY BETWEEN MS20470 AD RIVETS & CR 3243 RIVETS ALLOWABLE, DIA AND LENGTH MAY BE DETERMINED BY THE INSTALLER

RIVET LEGEND	
○	-MS20470 AD4(IN NEW HOLE)
⊗	-CR 3243-4(IN NEW HOLE)
⊙	-CR 3243-4(IN EXISTING HOLE)
●	-MS20426AD4-X(FLUSH RIVET)

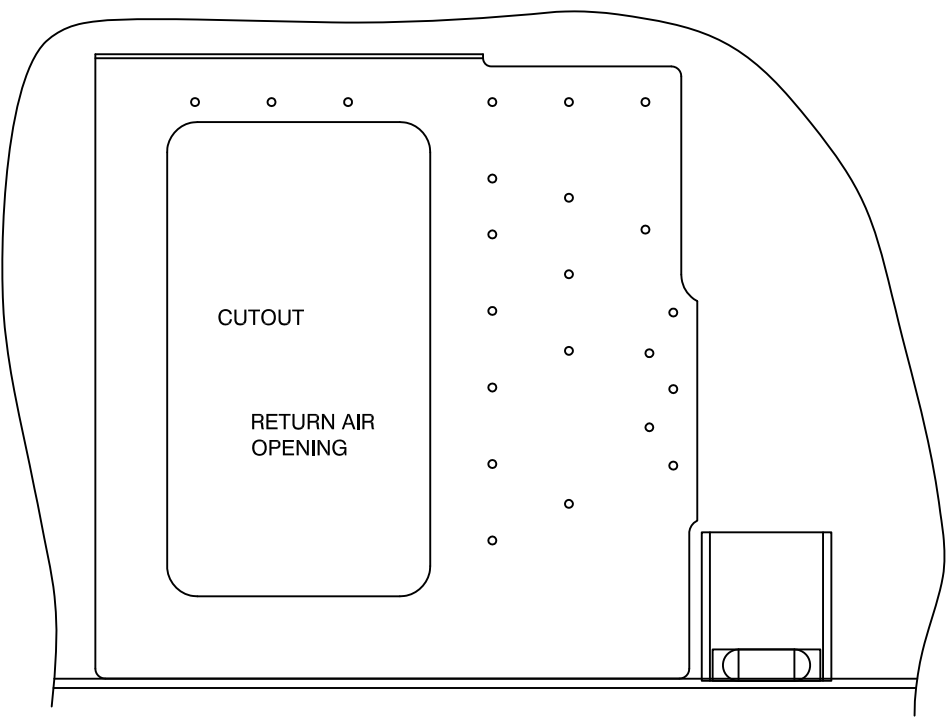

STEP 2
 MATCH DRILL DOUBLER TO AIRFRAME & AIRFRAME TO DOUBLER RIVET IN PLACE

STEP 3
 NOTE: ADD SCREEN SCREWS & SEAL EDGES

STEP 1
 NOTE: CUT OPENING IN INTERIOR AFT BULKHEAD PANEL TO MATCH RETURN AIR DOUBLER

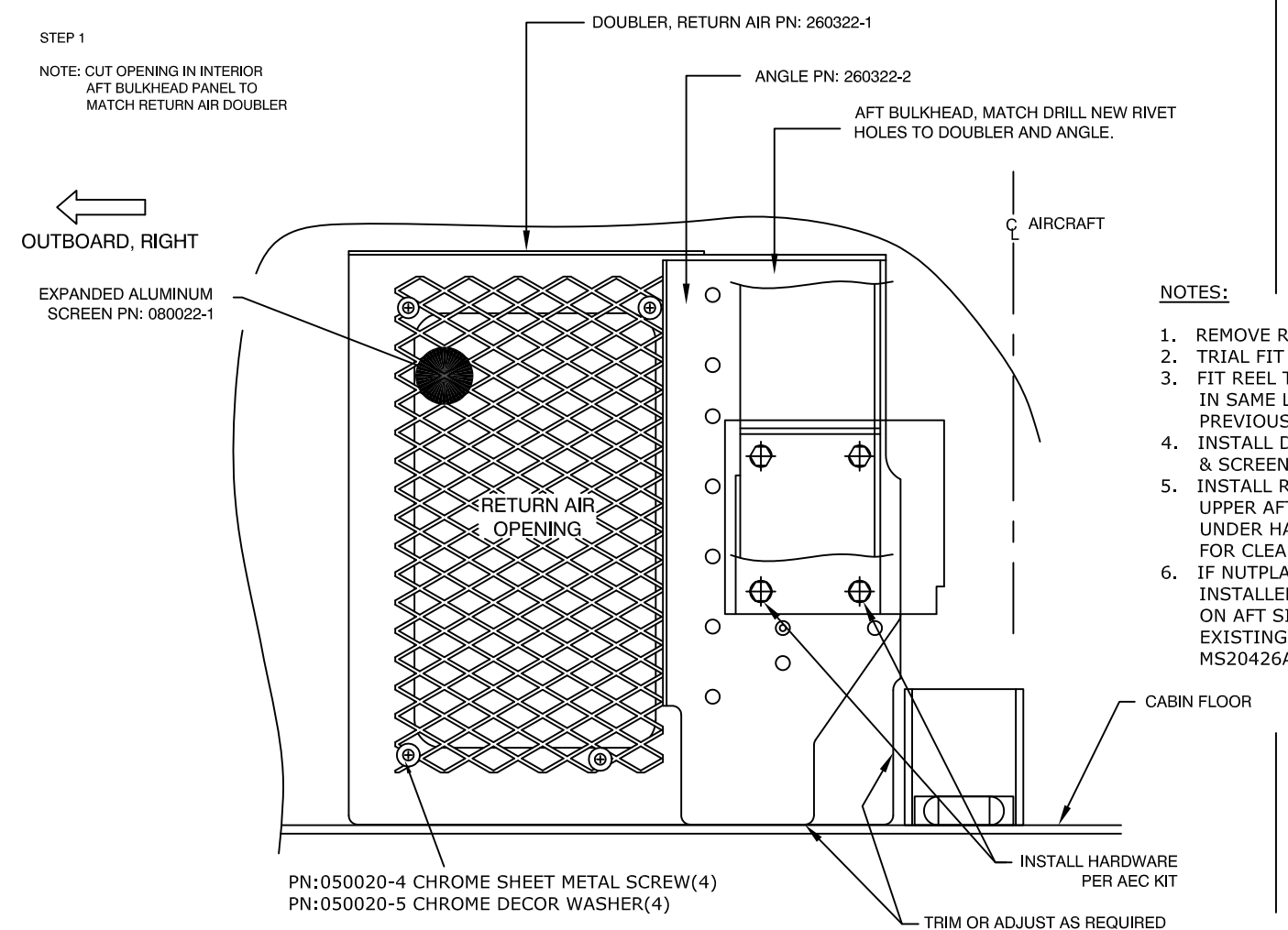

- NOTES:
1. REMOVE REEL
 2. TRIAL FIT DOUBLER ASSY
 3. FIT REEL TO DOUBLER ASSY IN SAME LOCATION AS PREVIOUSLY MOUNTED
 4. INSTALL DOUBLER ASSY & SCREEN
 5. INSTALL REEL, TRIMMING UPPER AFT TURNED LIP OF DOUBLER UNDER HARNESS, AS NECESSARY, FOR CLEARANCE
 6. IF NUTPLATES(TYP 4)ARE NOT INSTALLED, ADD PN MS21059-L3 ON AFT SIDE OF WALL, OR REINSTALL EXISTING NUT PLATES USING MS20426AD3-X OR CCR2645S3-X.

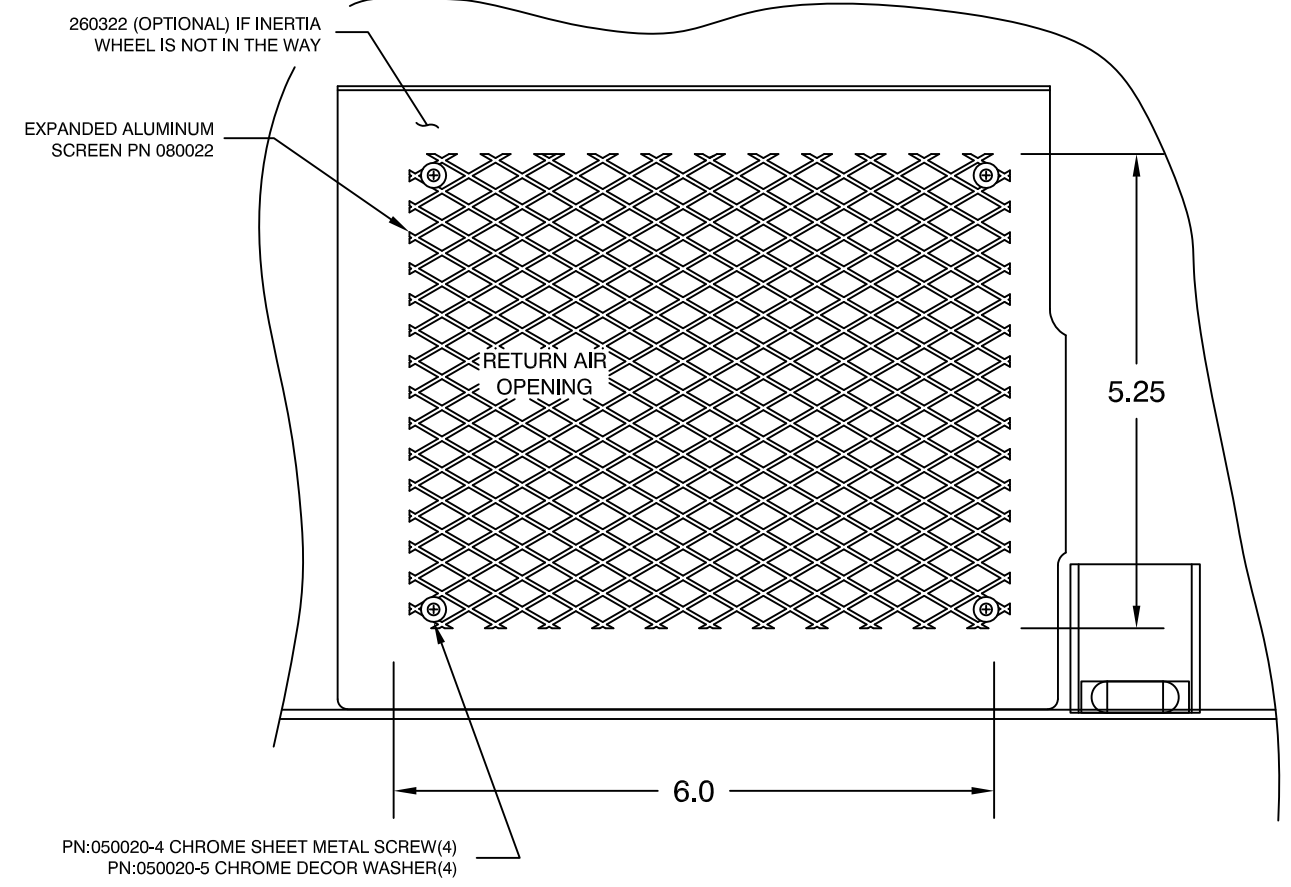

AFT CABIN BULKHEAD
 VIEW LOOKING AFT AT STA 106.29

PROPRIETARY NOTICE TO ALL PERSONS RECEIVING THIS DOCUMENT THIS DOCUMENT AND INFORMATION OR TECHNICAL DATA AND DESIGNS CONTAINED HEREIN ARE PROPRIETARY DATA AND EXCLUSIVE PROPERTY OF RSG PRODUCTS INC. AND IS DELIVERED ON THE EXPRESS CONDITION THAT NEITHER THIS DOCUMENT NOR THE INFORMATION CONTAINED HEREIN SHALL BE DISCLOSED TO OTHERS, REPRODUCED IN WHOLE OR IN PART, OR USED FOR THE MANUFACTURE OR FABRICATION OF PARTS FOR ANYONE OTHER THAN RSG PRODUCTS INC. WITHOUT WRITTEN CONSENT AND AUTHORIZATION, AND THAT NO RIGHT IS GRANTED TO DISCLOSE OR SO USE ANY INFORMATION CONTAINED IN SAD DOCUMENT. THIS RESTRICTION DOES NOT LIMIT THE RIGHT TO USE INFORMATION OBTAINED FROM ANOTHER SOURCE.	NEXT ASSY.	TOLERANCES EXCEPT AS SHOWN .X: ±.1 .XX: ±.03 .XXX: ±.010 X.X": ±.5" BREAK ALL SHARP EDGES .01 ALL DIMENSIONS IN INCHES UNLESS OTHERWISE STATED		
	APPROVED BY:	DATE:		TITLE: AIR DISTRIBUTION
	DRAWN BY: BP	DATE: 04/12/85		REV.: H
APPLICATION: AS350			DWG. NO.: 5-21-AS350	

Step 8

Installation of Compressor

Installation of Compressor

STEP	PROCEDURE	MECH	INSP
8.0	NOTE: MUST BE PERFORMED IN ACCORDANCE WITH CURRENT EUROCOPTER TECHNICAL DATA.		
8.1	Place a support on the transmission deck to support the engine drive while the shaft is disconnected for belt installation.		
8.2	Remove the cotter pins from the four pins holding the “Gimble Ring” at the Thomas coupling.		
8.3	Slide the “Gimble Ring” aft to gain access to the Thomas coupling.		
8.4	Remove the 6 bolts and Thomas coupling connecting the drive shaft and shift slightly aft.		
8.5	Install one (1) Compressor Drive belt.		
8.6	Reassemble the Thomas coupling per AEC Specifications. Torque and Safety Coupling!! Torque Mark all bolts.		
8.7	Add the remaining one (1) Compressor Drive belt to the spares/loose parts kit for future needs. NOTE: THE CURRENT BELT P/N 060018-1 HAS A SPECIFIC DIRECTION OF ROTATION. (See figure 1, page 3) NOTE: THE CURRENT BELT P/N 060005 HAS NO SPECIFIC DIRECTION OF ROTATION.		

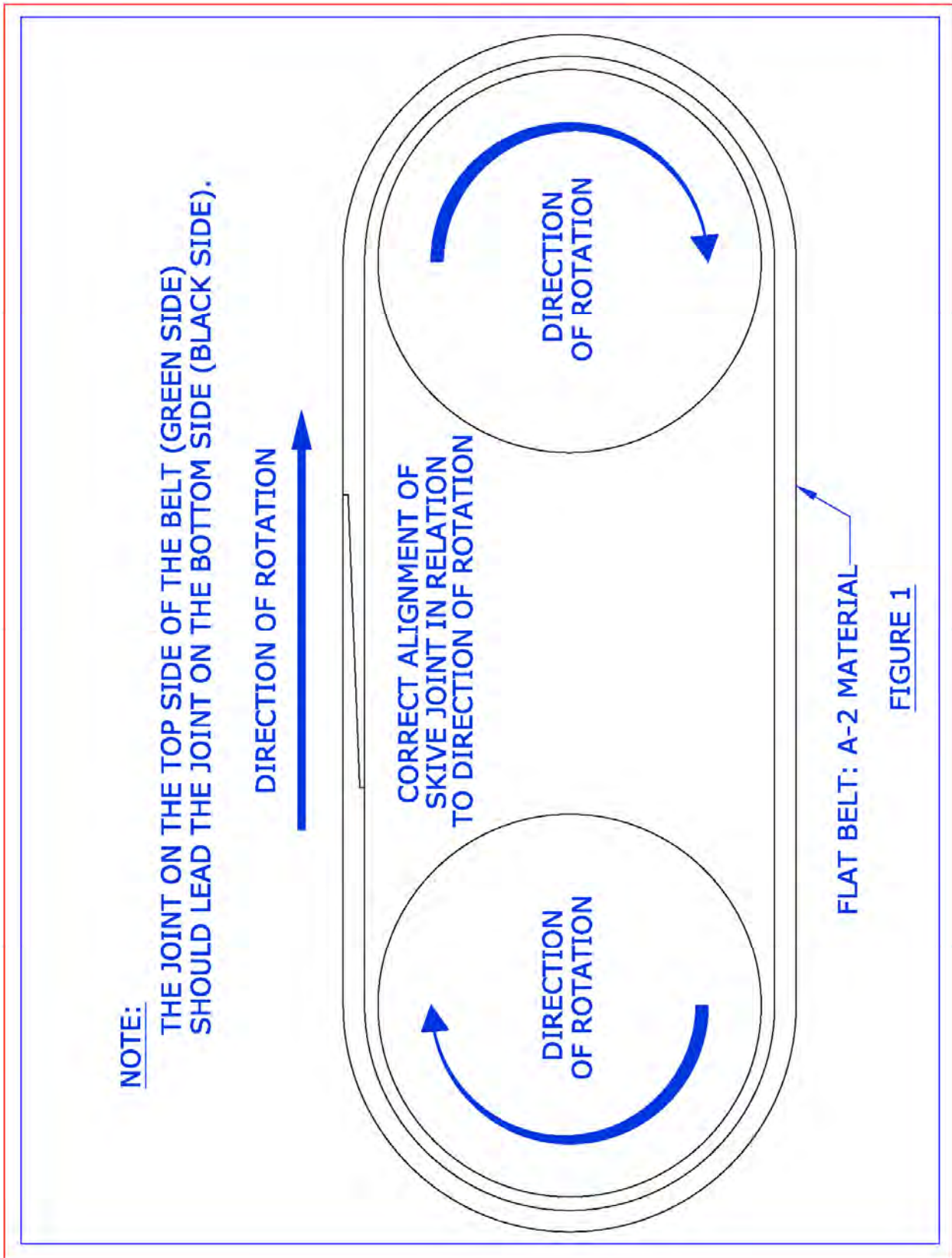
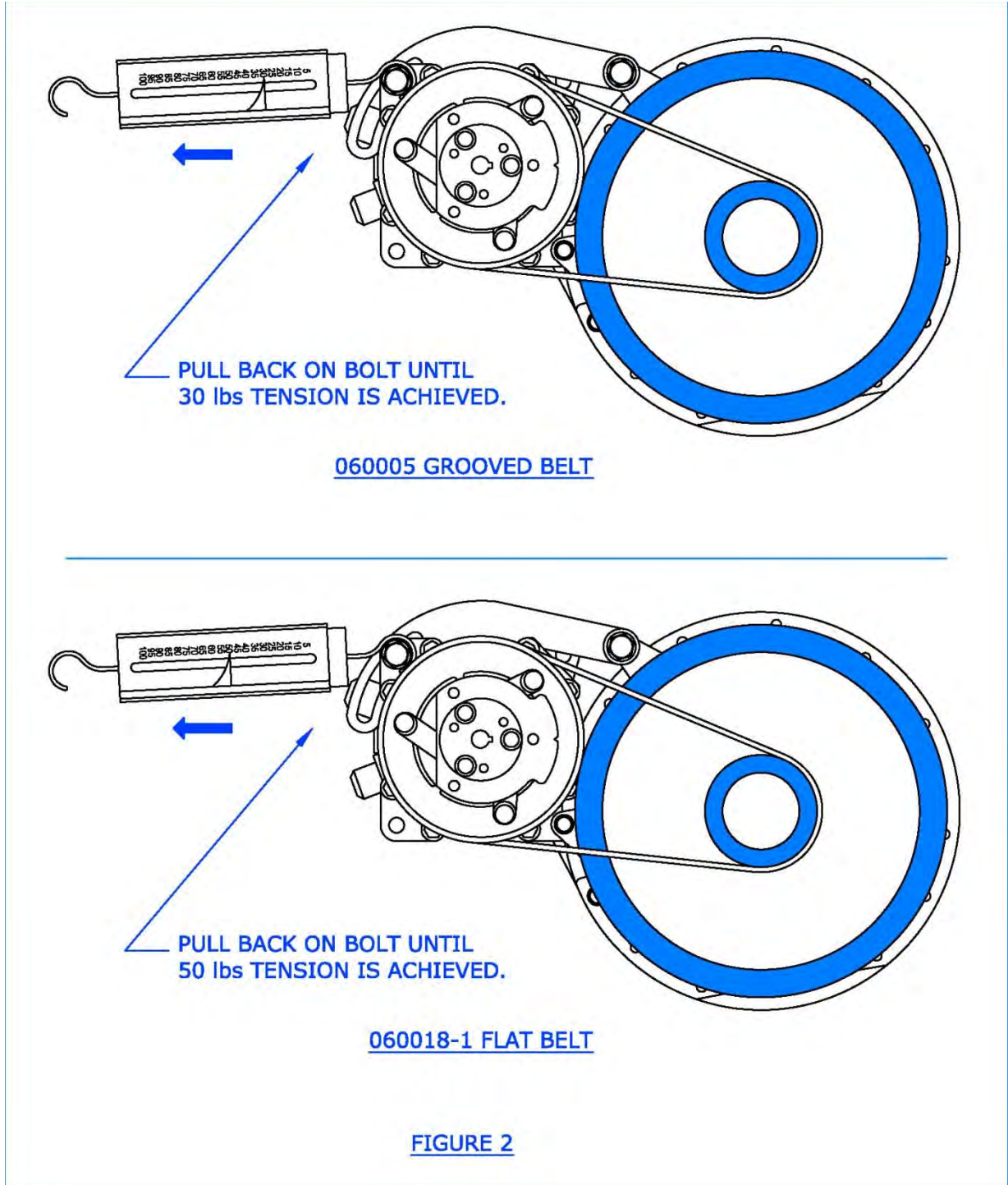

FIGURE 1

Installation of Compressor

STEP	PROCEDURE	MECH	INSP
8.8	Install the “Gimble Ring” pins and cotter pins. Remove supports.		
8.9	Installation of Bracket Kit P/N 350-11-031-02 in accordance with: 6-2-AS350, 6-12-AS350 and 6-21-AS350 or 6-3-AS350, 6-13-AS350 and 6-22-AS350.		
8.10	Install the Forward Compressor Bracket, Compressor Standoffs and Compressor per Drawings: 6-2-AS350, 6-12-AS350 and 6-21-AS350 or 6-3-AS350, 6-13-AS350 and 6-22-AS350		
8.11	Install the compressor drive belt on the drive pulley and the compressor clutch pulley. Tighten bolts at the adjustment arm assuring the belt proper amount of tension. Tighten the lower forward mounting bolt.		
8.12	This tension may be performed by either pull scale. (See Belt Tension Recommendation)		
8.13	50/30 lbs pull tension at tension adjustment bolt should provide adequate belt tension. (See figure 2, page 5)		
<p><u>BELT TENSION RECOMMENDATION:</u></p> <p>FLAT BELT P/N 060018-1 _____ TENSION TO 50lbs</p> <p>GROOVED BELT P/N 060005 _____ TENSION TO 30lbs</p>			

RSG Products Inc.
INSTALLATION OF COMPRESSOR – AS350 Air Conditioning



INSTALLATION INSTRUCTIONS:

KIT P/N: 350-00-011HP OR -031HP
(HIGH PERFORMANCE)

- 1) THE ABOVE TWO (2) KITS UTILIZE THE SANDEN SD-507 COMPRESSOR IFS PN: 590008 OR COMPRESSOR PN: 590008-1 IN LIEU OF THE SANDEN SD-505 IFS P/N: 590001-1-"O". AN INCREASE OF 2 CUBIC INCHES IN DISPLACEMENT IS ACHIEVED. BOTH UNITS HAVE THE SAME "FOOT PRINT". HOWEVER, THE SD-507 IS SLIGHTLY LONGER.
- 2) THE SAME BELT P/N's: 060018 OR 060018-1 ARE UTILIZED IN THIS INSTALLATION WITH COMPRESSOR PN: 590008. BELT P/N's: 060005 WILL BE UTILIZED WITH COMPRESSOR PN: 590008-1.
- 3) THE SAME COMPRESSOR MOUNT ASSEMBLY P/N: 530027-3, PIN P/N: 300095, AND COMPRESSOR STAND OFF P/N: 300067 ARE UTILIZED IN THIS INSTALLATIONS.
- 4) THE AFT, INBOARD COMPRESSOR MOUNTING POINT IS RELOCATED FORWARD BY PLACING TWO ALUMINIUM "BUSHINGS", P/N: 2610007 BETWEEN THE "STAND OFF" P/N: 300067 AND THE TRANSMISSION HOUSING. TWO (2) EACH AN4-15A BOLTS MUST BE UTILIZED IN LIEU OF THE AN4-11A FORMERLY USED.
- 6) THE FORWARD, UPPER INBOARD COMPRESSOR EAR IS ALIGNED WITH THE COMPRESSOR UNIT ASSEMBLY BY PLACING A "BUSHING", P/N 261008 BETWEEN THE AFT SIDE OF THE EAR AND THE MOUNT ASSEMBLY.
- 7) AN6-12A BOLTS ARE USED TO ENSURE BELT TENSION IN THE SAME MANNER AS WITH THE SD-505 COMPRESSOR. A MINIMUM THREAD PROTRUSION ON THE FORWARD UPPER BOLT REQUIRES THAT A STEEL SELF LOCKING NUT P/N: MS20364-624C MUST BE UTILIZED.

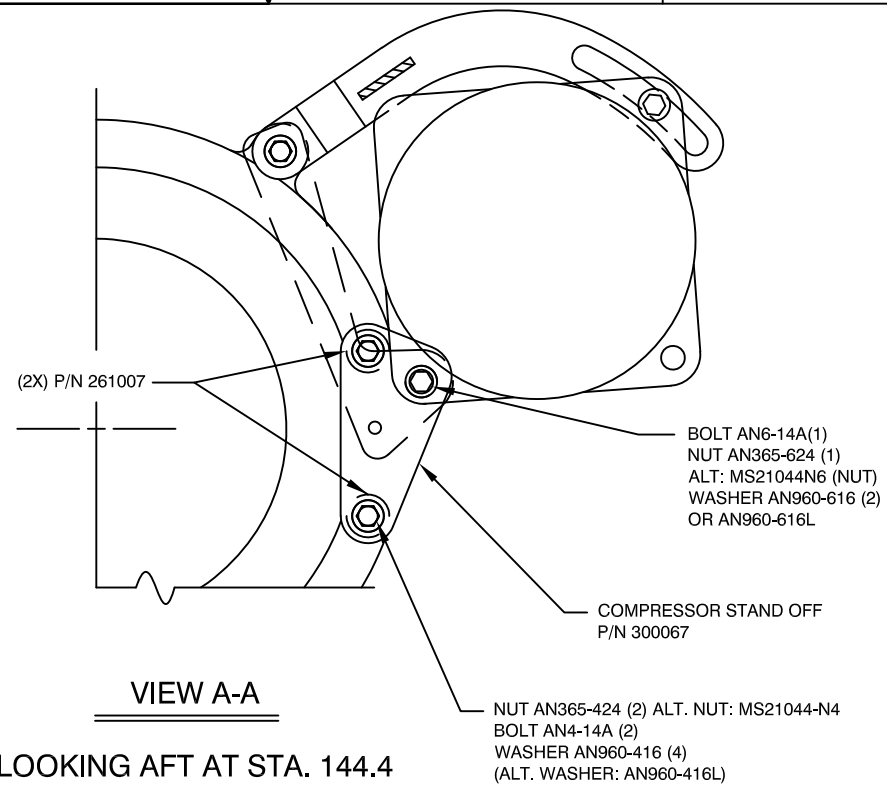

LOOKING AFT AT STA. 144.4

REVISION RECORD				
REV	DATE	DESCRIPTION OF CHANGE	APPVD. BY	REV. BY
A	08-16-00	REVISED DRAWING NUMBER, WAS 6-AS350 SHEET NUMBER WAS 1 OF 3.		
B	04/15/02	COMPUTERIZED, CHANGED TITLE BLOCK TO PAG. ADDED VIEW OF P/N 530100. CHANGED 530027-1 TO 530027-3.		
C	07/15/02	CHANGED PN: 261008 TO 2X PN: 261007, REVISED TITLE BLOCK.		
D	01/30/06	CHANGED BOLT, NAS1305-44 TO NAS1305-45 FOR EXTRA LENGTH. ADDED BELT PN 060018-1 TO ADDRESS LENGTH ISSUE. CHANGED NO. OF WASHERS ADDED "AS REQUIRED" TO WASHER NOTATION. ADDED COMPRESSOR PN: 590008-1 ADDED BELTS PN's 060005 AND 060006 FOR ALT. COMPRESSOR INSTALLATION. ADDED NOTATION TO CHANGE PULLEY ON TAIL ROTOR DRIVE SHAFT. REVISED APPLICABLE NOTATION.		JTYE
E	06/30/08	AEC PN: 350A351094 IS NOW PN: 350A35-1094-20. CORRECTED TO MATCH AEC IPC. REMOVED BELT PN: 060006, CORRECTED NOTE 2 TO MATCH. REVISED TITLE BLOCK.		JTYE
F	09/01/14	CHANGED TITLE BLOCK AND REVISION BLOCK.		AJC
G	01/19/22	ADDED ALTERNATE BOLT NAS6605-45 PER ECO 0941.		SGB

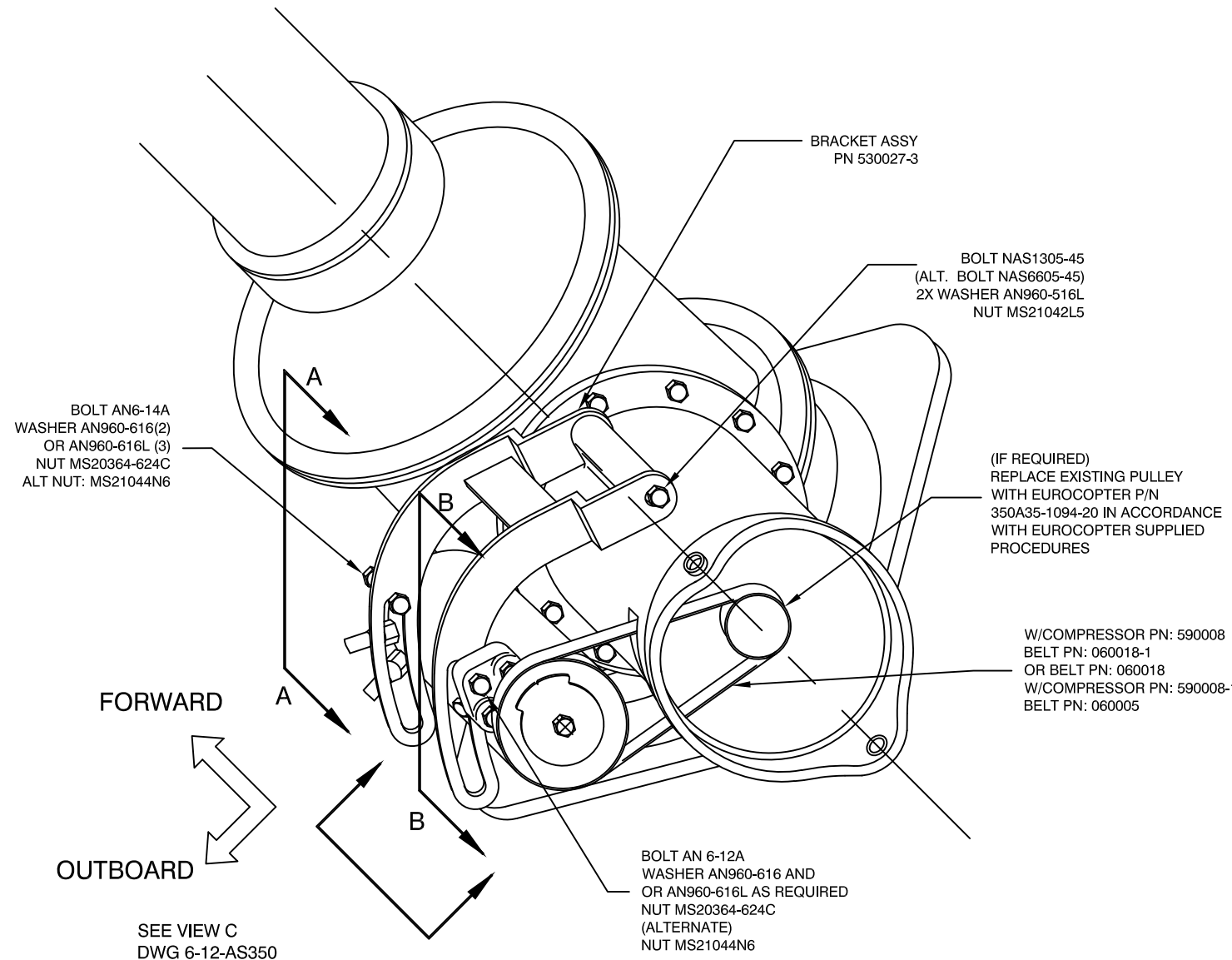

- UTILIZED WITH:**
1. AS 350 WITH OLDER TRANSMISSION HOUSING DESIGN.

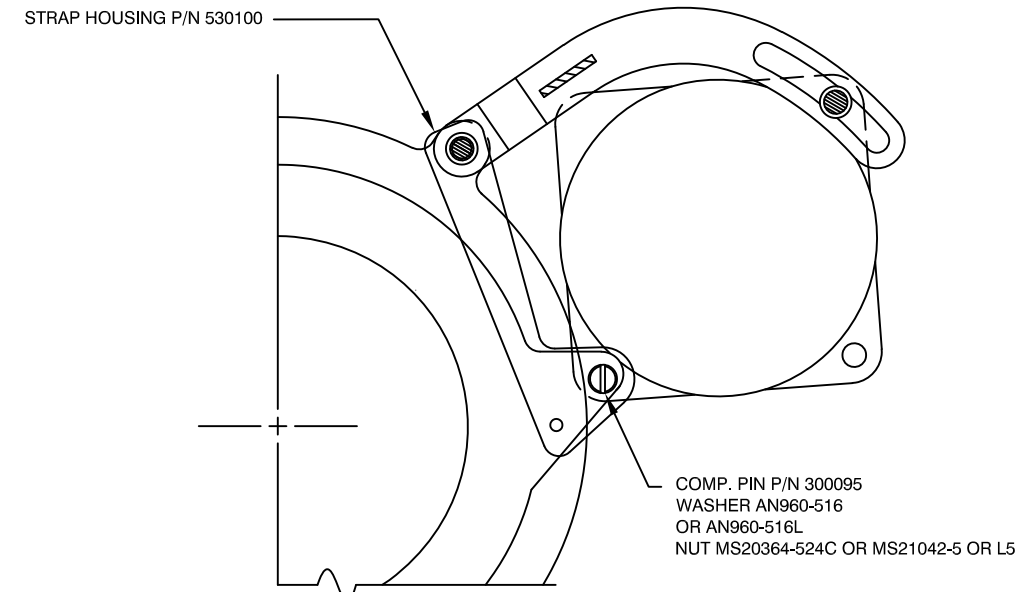

LOOKING AFT AT STA. 151.2

<p>PROPRIETARY NOTICE</p> <p>TO ALL PERSONS RECEIVING THIS DOCUMENT THIS DOCUMENT AND INFORMATION OR TECHNICAL DATA AND DESIGNS CONTAINED HEREIN ARE PROPRIETARY DATA AND EXCLUSIVE PROPERTY OF RSG PRODUCTS INC. AND IS DELIVERED ON THE EXPRESS CONDITION THAT NEITHER THIS DOCUMENT NOR THE INFORMATION CONTAINED HEREIN SHALL BE DISCLOSED TO OTHERS, REPRODUCED IN WHOLE OR IN PART, OR USED FOR THE MANUFACTURE OR FABRICATION OF PARTS FOR ANYONE OTHER THAN RSG PRODUCTS INC. WITHOUT WRITTEN CONSENT AND AUTHORIZATION, AND THAT NO RIGHT IS GRANTED TO DISCLOSE OR SO USE ANY INFORMATION CONTAINED IN SAID DOCUMENT. THIS RESTRICTION DOES NOT LIMIT THE RIGHT TO USE INFORMATION OBTAINED FROM ANOTHER SOURCE.</p>	<p>NEXT ASSY.</p>	<p>TOLERANCES EXCEPT AS SHOWN</p> <p>.X: ±.1 .XX: ±.03 .XXX: ±.010 X.X": ±.5° BREAK ALL SHARP EDGES .01 ALL DIMENSIONS IN INCHES UNLESS OTHERWISE STATED</p>		
	<p>APPROVED BY:</p>	<p>DATE:</p>		<p>TITLE: COMPRESSOR INSTALLATION</p>
	<p>DATE:</p>	<p>DATE:</p>		<p>DRAWN BY: BRP DATE: 11/10/96 REV.: G SCALE: N/A SHEET: 1 OF 1 APPLICATION: AS350 DWG. NO.: 6-2-AS350</p>

NOTES:

- UTILIZED ON AS350 WITH LATEST TRANSMISSION HOUSING DESIGN
- ALTERNATE FOR ITEM 16 COMPRESSOR IS P/N 590008 WHICH CAN ONLY BE USED WITH ITEM 7 ALTERNATE BELT P/N 060018-1.
- ENSURE PLANAR TOLERANCE BETWEEN THE TAIL ROTOR & COMPRESSOR PULLEY CENTERLINE IS ±.100 IN. ALIGNMENT CAN BE ADJUSTED BY CHANGING THE WASHER STACKUP BETWEEN ITEM 11 & GEAR BOX COUPLING CASE.
- REAM ITEM 10 BUSHING FOR PROPER FIT OF ITEM 12 PIN WITH RANGE .302 TO .359 IN.
- TENSION BELT TO F= 30 LBS. DEFLECTION AT CENTER OF THE BELT TO BE .10 IN. UNDER 5 LB LOAD.
- REPLACE EXISTING RING TERMINAL WITH ITEM 39 FOR USE WITH 1/4" HARDWARE ON BRACKET ASSEMBLY TO MOUNT GROUNDING STRAP ON ITEM 14. SEAL TERMINAL RING AND FASTENER WITH ITEM 38.
- COMPRESSOR BRACKET KIT P/N: 350-11-031-02. (SEE TABLE 1)

TABLE 1
COMPRESSOR BRACKET KIT P/N: 350-11-031-02

ITEM DESCRIPTION	PART NUMBER	QTY
COMPRESSOR MOUNT BRACKET	04-130-21-101-01	1
COMPRESSOR MOUNT TENSION BOLT	04-130-21-102-01	1
JAM NUT, DRILLED	04-130-21-104-01	2
COMPRESSOR CLAMP	04-130-21-105-01	2
BUSHING, SD 507	261007	2
COMPRESSOR STANDOFF	300067-1	1
UPPER COMPRESSOR SHIM	300363-2	2
COMPRESSOR PIN	300095	1
STRAP, HOUSING MOD ASSEMBLY	530100-1	1

REVISION RECORD				
REV	DATE:	DESCRIPTION OF CHANGE	APPVD. BY	REV. BY
D	09/01/14	CHANGED TITLE BLOCK AND REVISION BLOCK. ADDED AND CHANGED PART NUMBERS, DESCRIPTION AND QUANTITIES TO BOM PER ECO # 0568.		AJC
E	01/19/22	INCORPORATED ECO'S 0720, 0908, 0941 & 0982.		SGB
F	08/04/23	INCORPORATED ECO'S 1180 AND 1188.		SGB

SEE ECO 1290
SEE ECO 1300

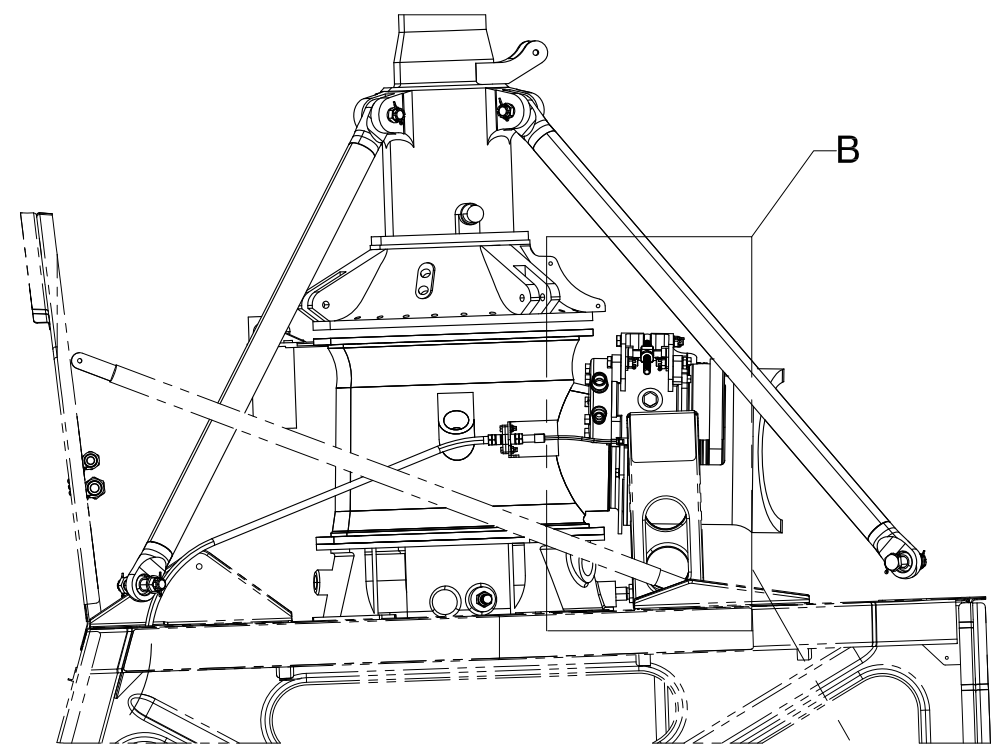
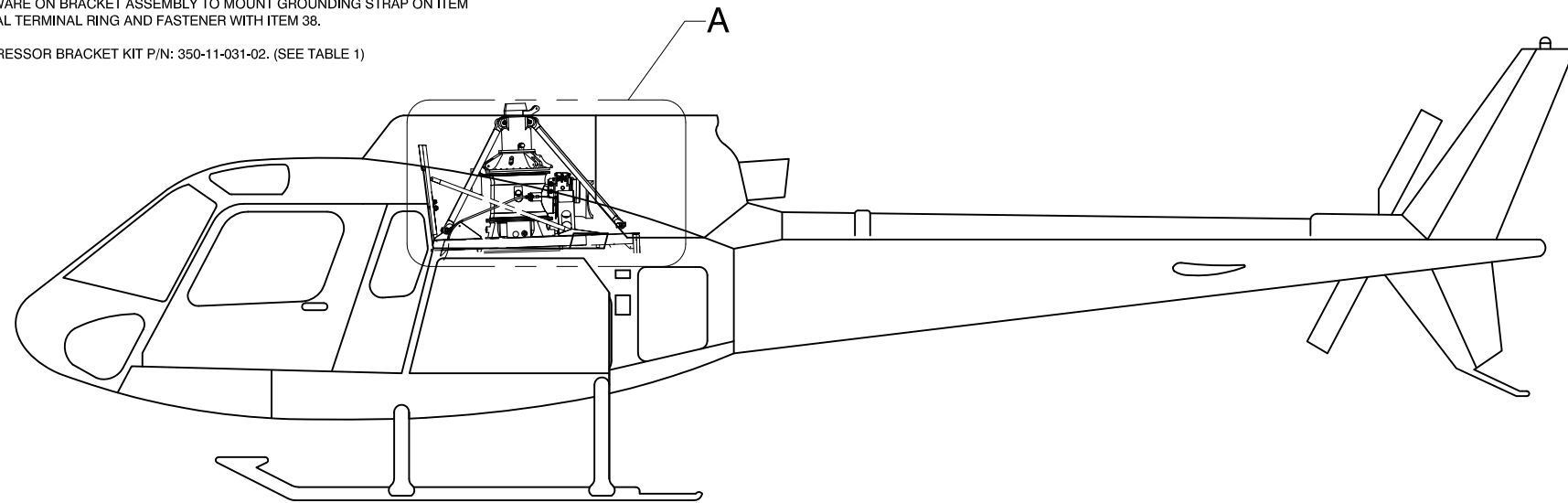

DETAIL A
(SOME A/C STRUCTURES REMOVED FOR CLARITY)
AFT →

1 REF OR 2 REF

QTY	QTY	ITEM	PART NUMBER	DESCRIPTION	VENDOR	WEIGHT
1	1	39	MS25036-150	RING TERMINAL		
A/R	A/R	38	PR 1440 B 1/2	SEALANT		
1	1	37	NAS1149DO416H	WASHER		
1	1	36	MS21042L4	NUT		
1	1	35	AN4-5A	BOLT		
	1	34	NAS1305-45	BOLT (ALT. NAS6605-45)		
6		33	NAS1149D0632H	WASHER		
2		32	NAS1149D0532H	WASHER		
	2	31	MS20364-624C	NUT (ALT. MS21044N6)		
	1	30	AN365-624	NUT (ALT. MS21044N6)		
4		29	MS21042L6	NUT		
2	2	28	MS21042L5	NUT (ALT. MS20364-524C)		
2	2	27	MS21042L4	NUT (ALT. AN365-424)		
A/R		26	MS20995C32	SAFETY WIRE		
2	A/R	25	AN960-616L	WASHER (ALT. AN960-616)		
1	3	24	AN960-516L	WASHER (ALT. AN960-516)		
4	4	23	AN960-416	WASHER (ALT. AN960-416L)		
1		22	AN6-33A	BOLT		
1	2	21	AN6-12	BOLT		
2		20	AN6-13A	BOLT		
	1	19	AN6-12A	BOLT		
1		18	AN5-34A	BOLT		
2	2	17	AN4-14A	BOLT		
1	1	16	590008-1	COMPRESSOR		12.85 LB
1	1	15	530100-1	STRAP HOUSING		
	1	14	530027-3	BRACKET ASSEMBLY		
1	1	13	300363-2	SHIM (ALT: 261155)		
1	1	12	300095	PIN		
1	1	11	300067-1	COMPRESSOR STAND OFF		
	1	10	261008	BUSHING		
2	2	9	261007	BUSHING		
1		8	2434K39	THREADED ROD END	McMASTER CARR	
1	1	7	060005	BELT		
2		6	04-130-21-105-01	COMPRESSOR CLAMP		
2		5	04-130-21-104-01	JAM NUT, DRILLED		
1	4	4	04-130-21-102-01	COMP MOUNT TENSION BOLT		
1	3	3	04-130-21-101-01	COMPRESSOR MOUNT BRACKET		0.52 LB
--		2	-02	COMPRESSOR INSTALLATION		
--		1	-01	COMPRESSOR INSTALLATION		

<p>PROPRIETARY NOTICE</p> <p>TO ALL PERSONS RECEIVING THIS DOCUMENT THIS DOCUMENT AND INFORMATION OR TECHNICAL DATA AND DESIGNS CONTAINED HEREIN ARE PROPRIETARY DATA AND EXCLUSIVE PROPERTY OF RSG PRODUCTS INC. AND IS DELIVERED ON THE EXPRESS CONDITION THAT NEITHER THIS DOCUMENT NOR THE INFORMATION CONTAINED HEREIN SHALL BE DISCLOSED TO OTHERS, REPRODUCED IN WHOLE OR IN PART, OR USED FOR THE MANUFACTURE OR FABRICATION OF PARTS FOR ANYONE OTHER THAN RSG PRODUCTS INC. WITHOUT WRITTEN CONSENT AND AUTHORIZATION, AND THAT NO RIGHT IS GRANTED TO DISCLOSE OR SO USE ANY INFORMATION CONTAINED IN SAID DOCUMENT. THIS RESTRICTION DOES NOT LIMIT THE RIGHT TO USE INFORMATION OBTAINED FROM ANOTHER SOURCE.</p>	<p>NEXT ASSY.</p>	<p>TOLERANCES EXCEPT AS SHOWN</p> <p>.X: ±.1 .XX: ±.03 .XXX: ±.010 X.X": ±.5° BREAK ALL SHARP EDGES .01 ALL DIMENSIONS IN INCHES UNLESS OTHERWISE STATED</p>			
	<p>APPROVED BY:</p>	<p>DATE:</p>		<p>TITLE: COMPRESSOR INSTALLATION</p>	
<p>DRAWN BY: S.THORNTON</p>		<p>DATE: 10/03/2012</p>	<p>REV.: F</p>	<p>SCALE: N/A</p>	<p>SHEET: 1 OF 3</p>
<p>APPLICATION: AS350</p>		<p>DWG. NO.: 6-3-AS350</p>			

NOTES:
(APPLICABLE TO -02 CONFIGURATION ONLY)

- 1 PERMISSIBLE TO USE ALTERNATE COTTER PIN TYPE HARDWARE:
BOLT ANX-XX, NUT AN310-X, COTTER PIN MS24665-XXX.
- 2 TIGHTEN BOTH NUTS AGAINST THE COMP MOUNT TENSION
BOLT. SAFETY WIRE NUTS USING ITEM 26 IAW MS33540.
- 3 OLD AND NEW COMPRESSOR MOUNT BRACKET
04-130-21-101-01 TO REPLACE 530027-3.

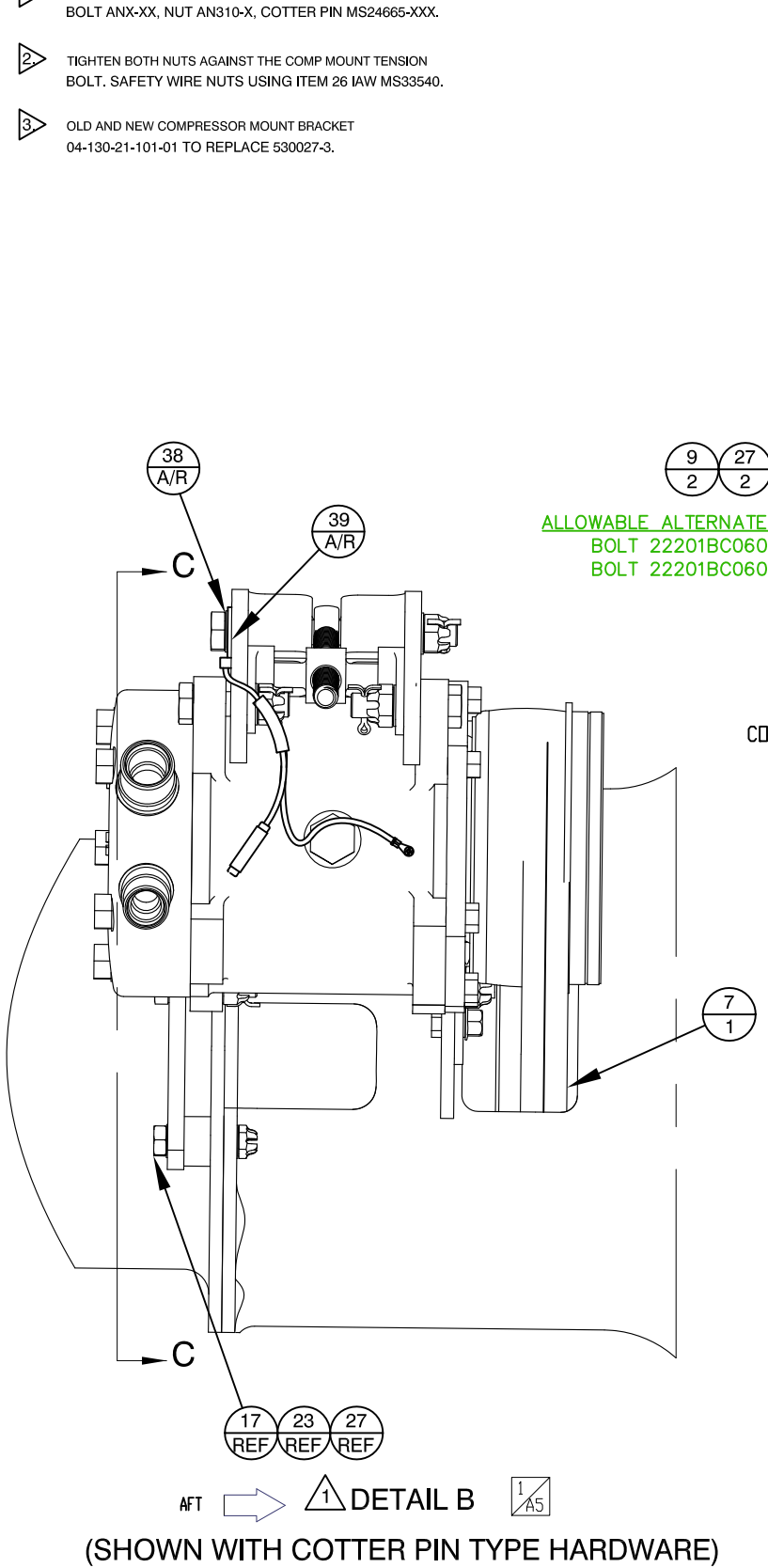

ALLOWABLE ALTERNATE METRIC HARDWARE
BOLT 22201BC060006L (X1)
BOLT 22201BC060027L (X2)

GEAR BOX
COUPLING CASE

PULLEY

SECTION C-C (VIEW LOOKING AFT)
(SHOWN WITH COTTER PIN TYPE HARDWARE)

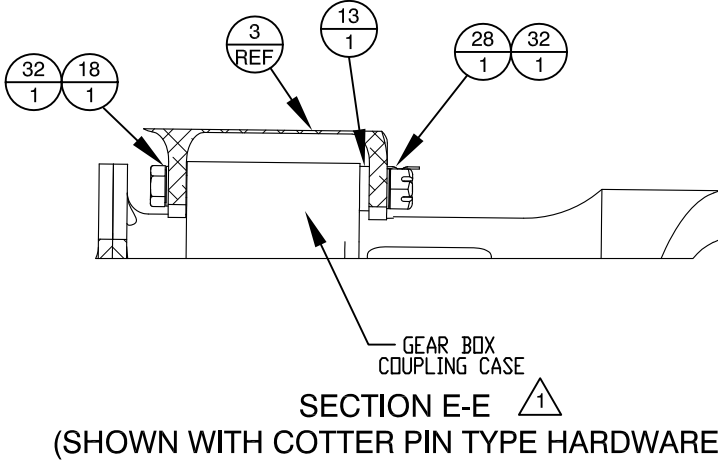
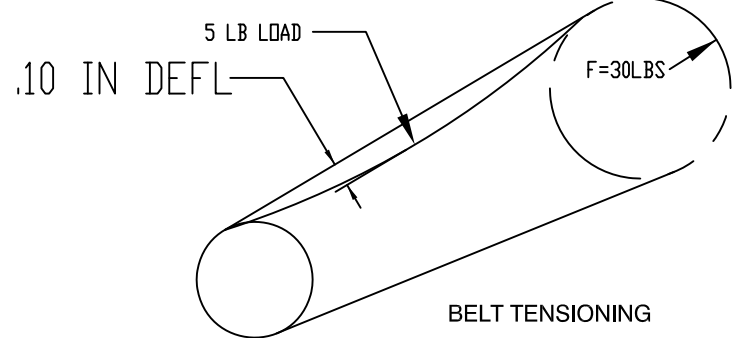

SECTION E-E (SHOWN WITH COTTER PIN TYPE HARDWARE)

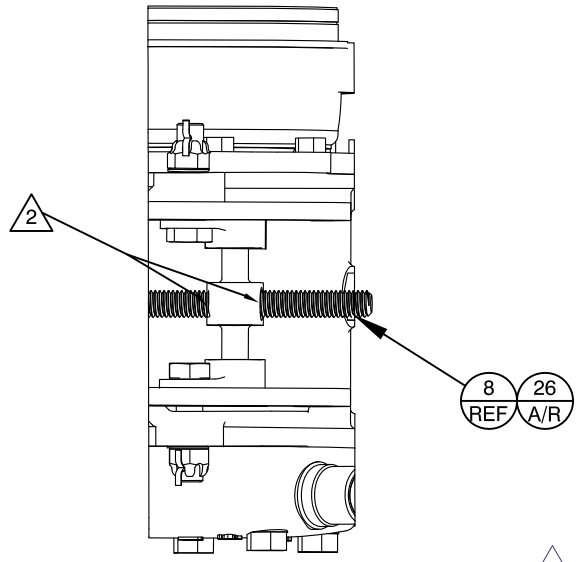

SECTION D-D (VIEW LOOKING DOWN)
(SHOWN WITH COTTER PIN TYPE HARDWARE)

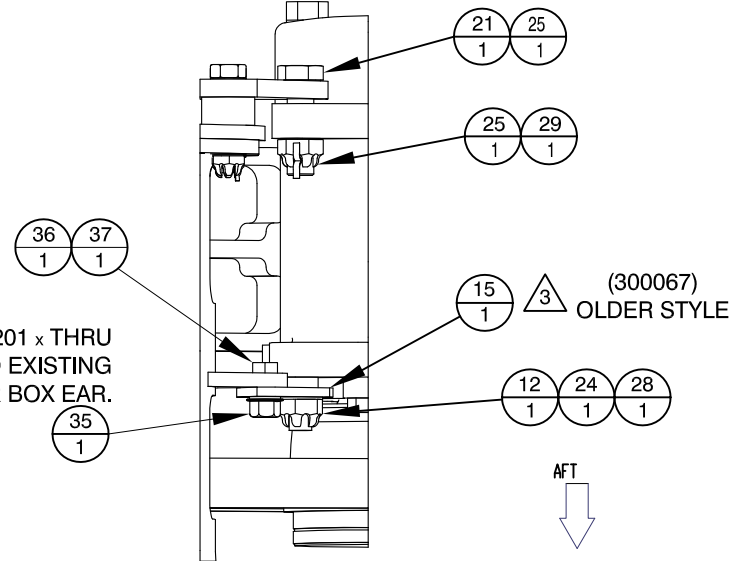

SECTION F-F (VIEW LOOKING UP.)
(SHOWN WITH COTTER PIN TYPE HARDWARE)

MATCH DRILL Ø.201 x THRU
ITEM 15 TO EXISTING
HOLE IN GEAR BOX EAR.

(300067) OLDER STYLE

-02



TITLE: COMPRESSOR INSTALLATION				
DRAWN BY: S. THORNTON	DATE: 10/03/2012	REV.:	SCALE: N/A	SHEET: 2 OF 3
APPLICATION: AS350				DWG. NO.:
				6-3-AS350

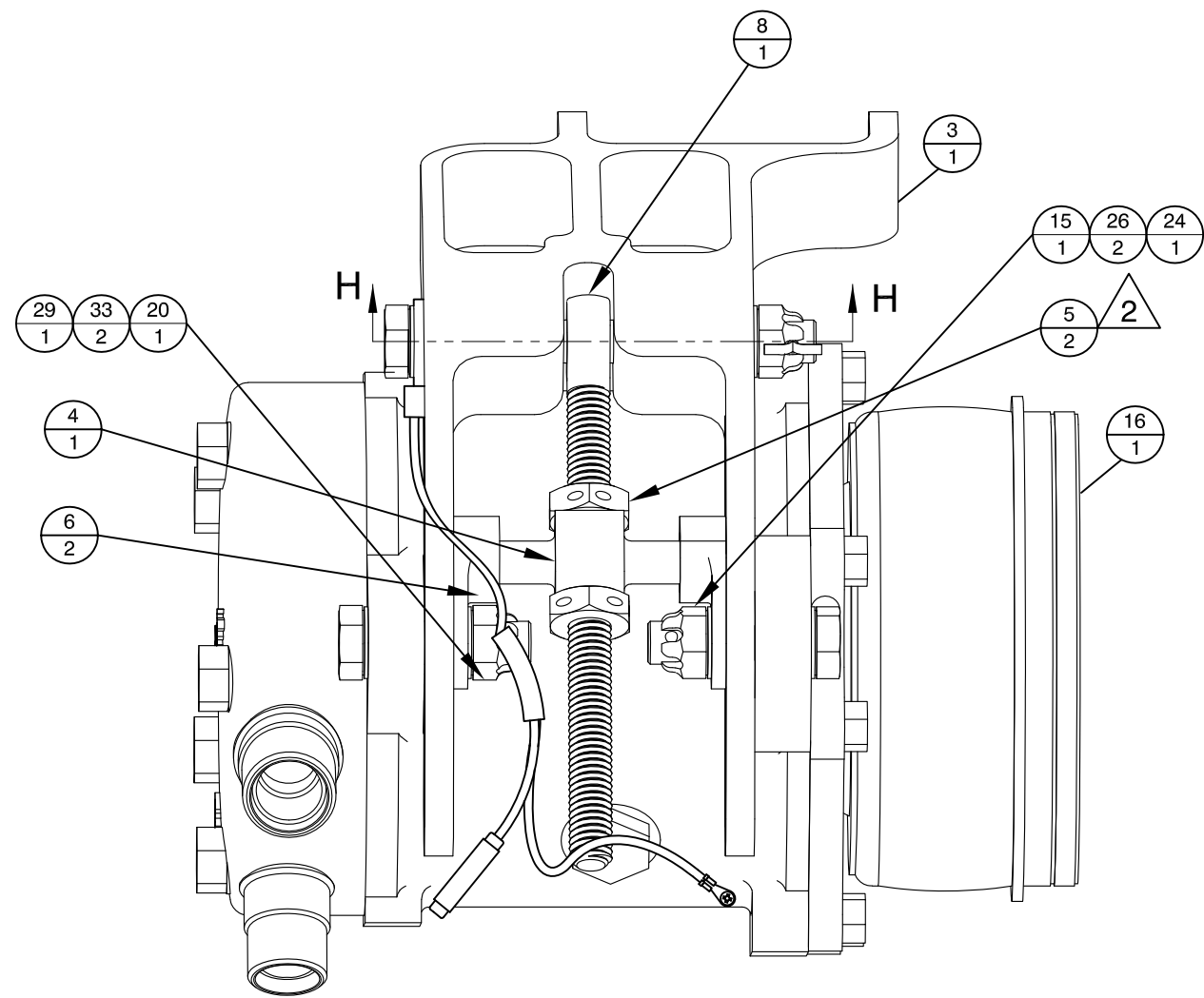

VIEW G-G $\triangle 1$
 (SHOWN WITH COTTER PIN TYPE HARDWARE)

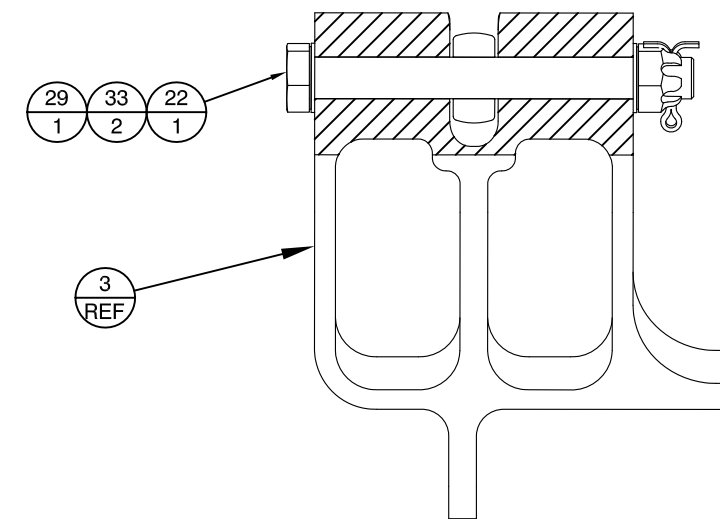

SECTION H-H $\triangle 1$
 (SHOWN WITH COTTER PIN TYPE HARDWARE)

-02 (CONTINUED)



TITLE: COMPRESSOR INSTALLATION				
DRAWN BY: S. THORNTON	DATE: 10/03/2012	REV.: F	SCALE: N/A	SHEET: 3 OF 3
APPLICATION: AS350			DWG. NO.: 6-3-AS350	



ENGINEERING CHANGE ORDER

ECO No.	1290	SHT	1	OF	1
DWG No.	6-3-AS350	REV	F		
DWG No.		REV			
DWG No.		REV			
REF. STC No.	SH3509SW				

CHANGE CLASS:
 RECORD CHG. PARTS NOT AFFECTED NON-INTERCHANGEABLE PARTS
 INTERCHANGEABLE PARTS OTHER _____

EXISTING/IN-WORK STOCK DISPOSITION:
 RECORD CHG. PARTS NOT AFFECTED RE-WORK EXISTING STOCK
 SCRAP EXISTING STOCK OTHER BREAK IN AT NEXT BUILD

EFFECTIVITY:
 ALL UNITS THIS CUSTOMER LIMITED UNITS SPECIFIED
 ALL UNITS MFG'D AFTER THIS DATE OTHER ALL UNITS

DESCRIPTION OF CHANGE: CORRECT ALT. PART NUMBERS FOR ITEMS 23, 24 AND 25.

WAS:

2	A/R	25	AN960-616L	WASHER (ALT. AN960-616)		
1	3	24	AN960-516L	WASHER (ALT. AN960-516)		
4	4	23	AN960-416	WASHER (ALT. AN960-416L)		
QTY	QTY	ITEM	PART NUMBER	DESCRIPTION	VENDOR	WEIGHT

IS:

2	A/R	25	AN960-616L	WASHER (ALT. NAS1149F0632P)		
1	3	24	AN960-516L	WASHER (ALT. NAS1149F0532P)		
4	4	23	AN960-416	WASHER (ALT. NAS1149F0463P)		
QTY	QTY	ITEM	PART NUMBER	DESCRIPTION	VENDOR	WEIGHT

REMARKS: MINOR CHANGE.
CORRECTED ALT. P/N'S.

ENGINEERING REVIEW BOARD		
SIGNATURE	STAMP	DATE
	MRB04	1/13/2024
	QA22 PO16	1/18/2024 1/18/2024
INCORPORATION STATUS		
<input type="checkbox"/> IMMEDIATE <input checked="" type="checkbox"/> OUTSTANDING		



ENGINEERING CHANGE ORDER

ECO No.	1300	SHT 1 OF 2
DWG No.	6-3-AS350	REV F
DWG No.		REV
DWG No.		REV

REF. STC No. **SH3509SW**

CHANGE CLASS:
 RECORD CHG. PARTS NOT AFFECTED NON-INTERCHANGEABLE PARTS
 INTERCHANGEABLE PARTS OTHER _____

EXISTING/IN-WORK STOCK DISPOSITION:
 RECORD CHG. PARTS NOT AFFECTED RE-WORK EXISTING STOCK
 SCRAP EXISTING STOCK OTHER BREAK IN AT NEXT BUILD

EFFECTIVITY:
 ALL UNITS THIS CUSTOMER LIMITED UNITS SPECIFIED
 ALL UNITS MFG'D AFTER THIS DATE OTHER ALL UNITS

DESCRIPTION OF CHANGE: ADD MISSING HARDWARE PARTS FOR COMPRESSOR BRACKET KIT TO TABLE 1.

WAS:

TABLE 1
COMPRESSOR BRACKET KIT P/N: 350-11-031-02

ITEM DESCRIPTION	PART NUMBER	QTY
COMPRESSOR MOUNT BRACKET	04-130-21-101-01	1
COMPRESSOR MOUNT TENSION BOLT	04-130-21-102-01	1
JAM NUT, DRILLED	04-130-21-104-01	2
COMPRESSOR CLAMP	04-130-21-105-01	2
BUSHING, SD 507	261007	2
COMPRESSOR STANDOFF	300067-1	1
UPPER COMPRESSOR SHIM	300363-2	2
COMPRESSOR PIN	300095	1
STRAP, HOUSING MOD ASSEMBLY	530100-1	1

REMARKS: MINOR CHANGE.
ADD MISSING PARTS.

ENGINEERING REVIEW BOARD		
SIGNATURE	STAMP	DATE
	MRB04	3/14/2024
	QA22	3/14/2024
	P016	3/15/2024
INCORPORATION STATUS		
<input type="checkbox"/> IMMEDIATE <input checked="" type="checkbox"/> OUTSTANDING		



ENGINEERING
CHANGE
ORDER

ECO No.	1300	SHT	2 OF 2
DWG No.	6-3-AS350	REV	F
DWG No.		REV	
DWG No.		REV	
REF. STC No.	SH3509SW		

IS:

TABLE 1
COMPRESSOR BRACKET KIT P/N: 350-11-031-02

ITEM DESCRIPTION	PART NUMBER	QTY	COMMENT
COMPRESSOR MOUNT BRACKET	04-130-21-101-01	1	
COMPRESSOR MOUNT TENSION BOLT	04-130-21-102-01	1	
JAM NUT, DRILLED	04-130-21-104-01	2	
COMPRESSOR CLAMP	04-130-21-105-01	2	
BUSHING, SD 507	261007	2	
COMPRESSOR STANDOFF	300067-1	1	
UPPER COMPRESSOR SHIM	300363-2	2	
COMPRESSOR PIN	300095	1	
STRAP, HOUSING MOD ASSEMBLY	530100-1	1	
THREADED ROD END	2434K39	1	
WASHER	NAS1149D0416H	1	OR NAS HARDWARE EQUIVALENT
WASHER	NAS1149D0635H	6	OR NAS HARDWARE EQUIVALENT
WASHER	NAS1149D0532H	2	OR NAS HARDWARE EQUIVALENT
WASHER	AN960-416	4	ALT (NAS1149F0463P)
WASHER	AN960-516L	1	ALT (NAS1149F0532P)
WASHER	AN960-616L	2	ALT (NAS1149F0632P)
NUT	MS21042-L5	2	ALT (MS20364-524C)
NUT	MS21042-L4	3	ALT (AN365-424)
NUT	MS21042L6	4	OR NAS HARDWARE EQUIVALENT
BOLT	AN4-5A	1	OR NAS HARDWARE EQUIVALENT
BOLT	AN4-14A	2	OR NAS HARDWARE EQUIVALENT
BOLT	AN5-34A	1	OR NAS HARDWARE EQUIVALENT
BOLT	AN6-13A	2	OR NAS HARDWARE EQUIVALENT
BOLT HEX DRIVE	AN6-12	1	OR NAS HARDWARE EQUIVALENT
BOLT	AN6-33A	1	OR NAS HARDWARE EQUIVALENT

REVISION RECORD				
REV	DATE	DESCRIPTION OF CHANGE	APPVD. BY	REV. BY
A	08/16/00	REVISED DRAWING NUMBER, WAS 6-AS350, SHEET No. WAS 2 OF 3.		
B	04/16/02	COMPUTERIZED, CLARIFIED NOTE, REVISED TITLE BLOCK.		
c	01/30/06	CHANGED NOTES, ADDED PRELOAD NOTE. ADDED SHIMMING NOTES.		JTYE
D	06/30/08	REVISED TITLE BLOCK.		JTYE
E	9/1/14	CHANGED TITLE BLOCK AND REVISION BLOCK. CORRECTED HARDWARE CALLOUT PER ECO # 0261.		AJC

NOTE:
DO NOT CUT TRANSMISSION
FLANGE-NOT REQUIRED

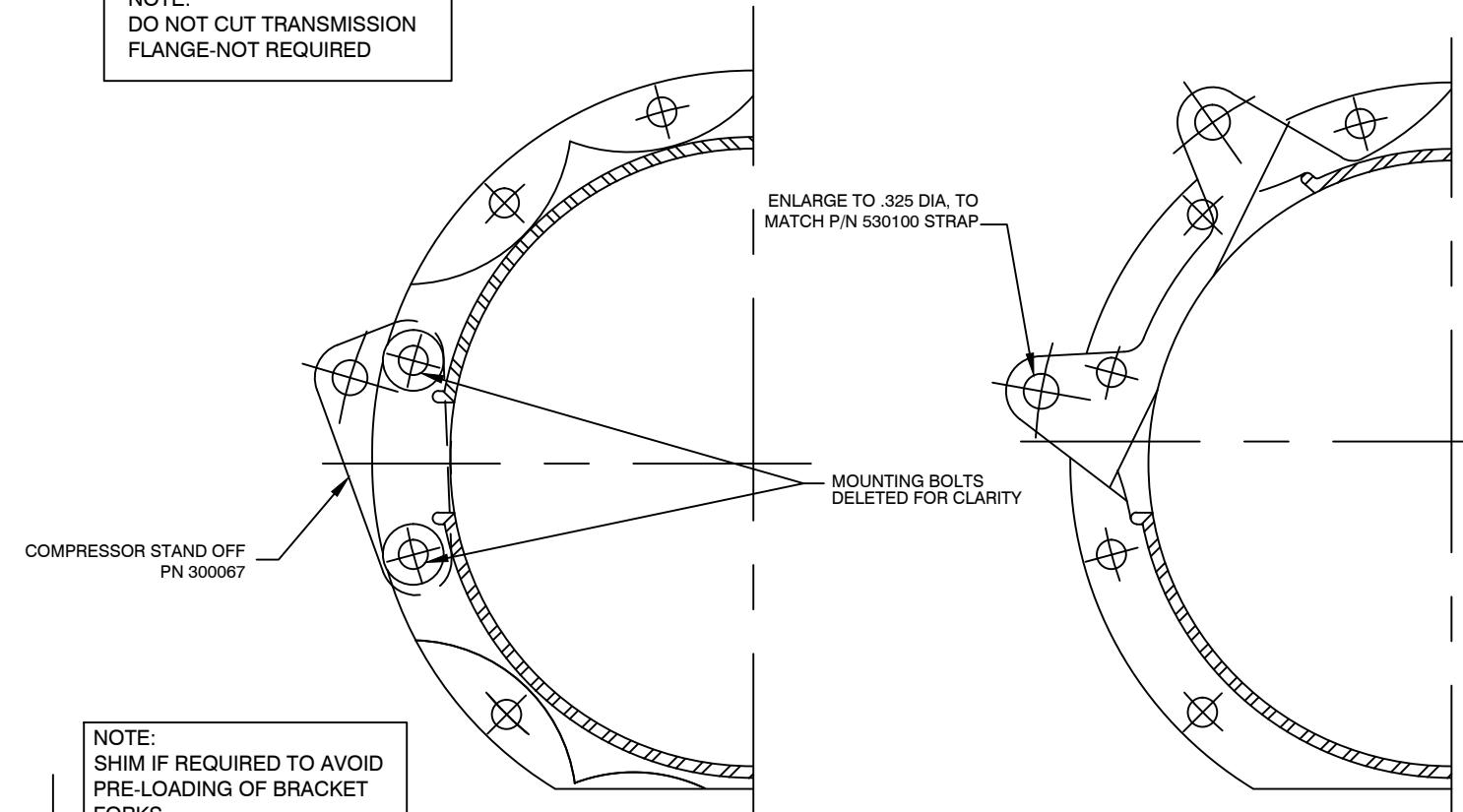

NOTE:
SHIM IF REQUIRED TO AVOID
PRE-LOADING OF BRACKET
FORKS.

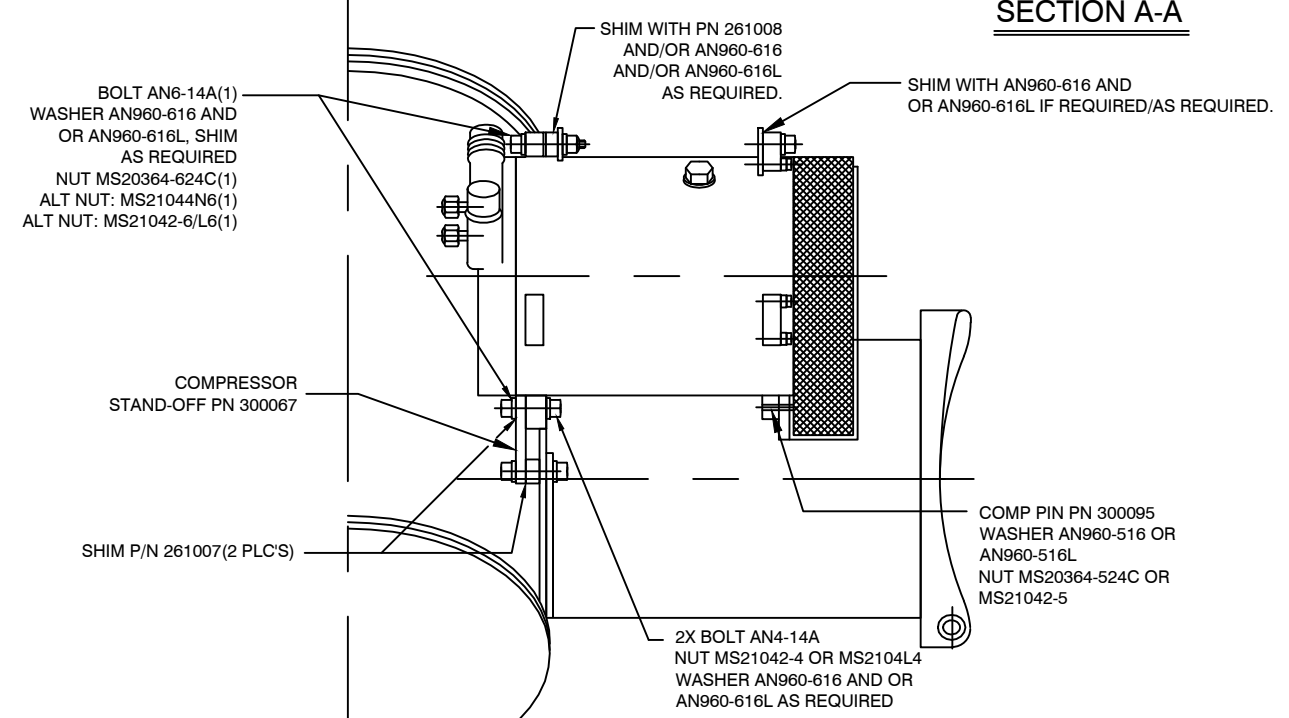

VIEW C
REF 6-2-AS350

FORWARD

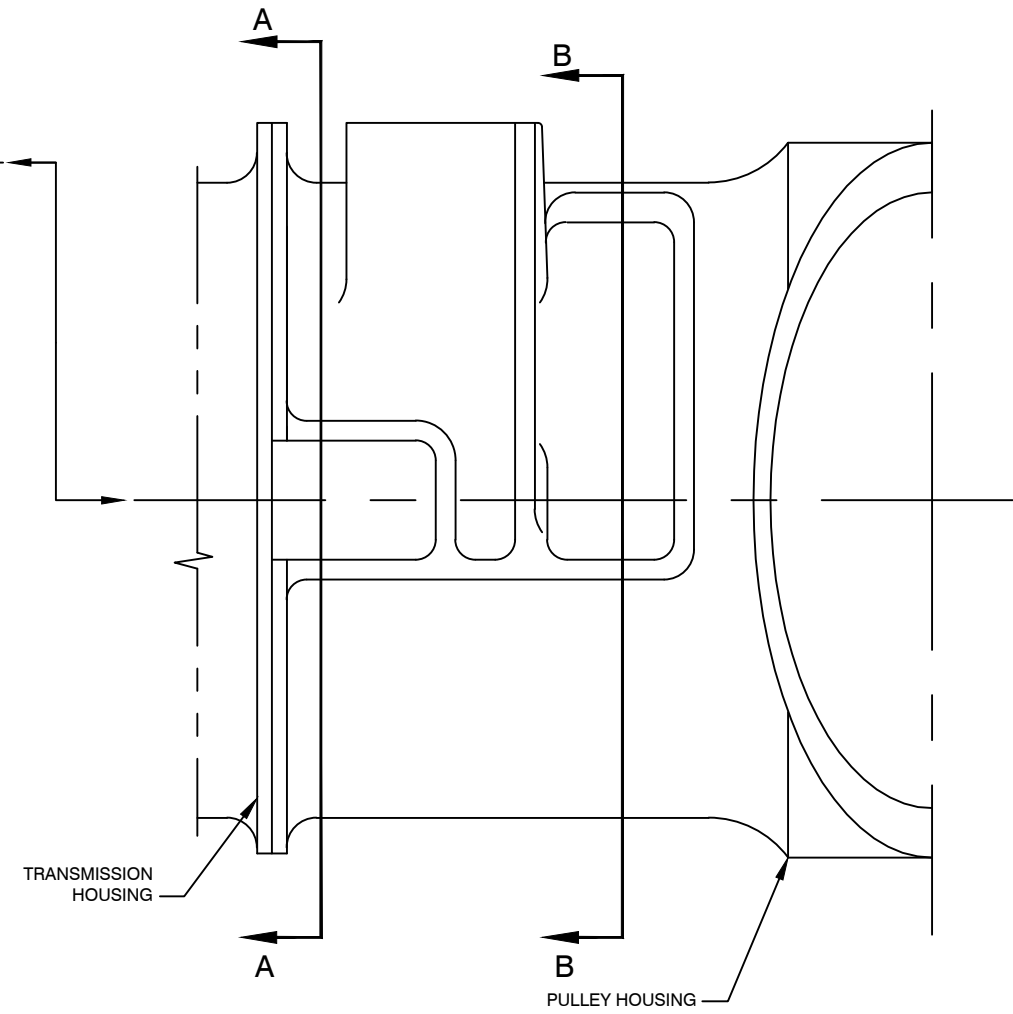

**FORWARD
VIEW LOOKING INBOARD**

PROPRIETARY NOTICE TO ALL PERSONS RECEIVING THIS DOCUMENT THIS DOCUMENT AND INFORMATION OR TECHNICAL DATA AND DESIGNS CONTAINED HEREIN ARE PROPRIETARY DATA AND EXCLUSIVE PROPERTY OF RSG PRODUCTS INC. AND IS DELIVERED ON THE EXPRESS CONDITION THAT NEITHER THIS DOCUMENT NOR THE INFORMATION CONTAINED HEREIN SHALL BE DISCLOSED TO OTHERS, REPRODUCED IN WHOLE OR IN PART, OR USED FOR THE MANUFACTURE OR FABRICATION OF PARTS FOR ANYONE OTHER THAN RSG PRODUCTS INC. WITHOUT WRITTEN CONSENT AND AUTHORIZATION, AND THAT NO RIGHT IS GRANTED TO DISCLOSE OR SO USE ANY INFORMATION CONTAINED IN SAD DOCUMENT. THIS RESTRICTION DOES NOT LIMIT THE RIGHT TO USE INFORMATION OBTAINED FROM ANOTHER SOURCE.	NEXT ASSY.	TOLERANCES EXCEPT AS SHOWN		
		.X: ±.1 .XX: ±.03 .XXX: ±.010 X.X°: ±.5° BREAK ALL SHARP EDGES .01 ALL DIMENSIONS IN INCHES UNLESS OTHERWISE STATED		TITLE: COMPRESS INSTALLATION
	APPROVED BY:	DATE:	DATE: 11/10/96	DRAWN BY: BT DATE: 11/10/96 REV.: E SCALE: N/A SHEET: 1 OF 1
				APPLICATION: AS350 DWG. NO.: 6-12-AS350

REVISION RECORD				
REV	DATE	DESCRIPTION OF CHANGE	APPVD. BY	REV. BY
A	01/30/06	CHANGED WASHER NOTES FOR PRE-LOADING OF BRACKET.		JTYE
B	06/30/08	REVISED TITLE BLOCK.		JTYE
C	9/1/14	CHANGED TITLE BLOCK AND REVISION BLOCK. CORRECTED HARDWARE CALLOUT PER ECO # 0261.		AJC

NOTE:
DO NOT CUT TRANSMISSION
FLANGE-NOT REQUIRED

BACKDRILL TO P/N 530100-1
WITH THIS HOLE USING Ø.250.

COMPRESSOR STAND OFF
PN 300067-1

NOTE:
SHIM IF REQUIRED TO AVOID
PRE-LOADING OF BRACKET
FORKS.

MOUNTING BOLTS
DELETED FOR CLARITY

530100-1
FLUSH TO
THIS EDGE.

FLUSH AGAINST
MACHINED EDGE.

SECTION A-A

SECTION B-B

BOLT AN6-14A(1)
WASHER AN960-616 AND
OR AN960-616L, SHIM
AS REQUIRED
NUT MS20364-624C(1)
ALT NUT: MS21044N6(1)
ALT NUT: MS21042-6/L6(1)

SHIM WITH PN 261008
AND/OR AN960-616
AND/OR AN960-616L
AS REQUIRED.

SHIM WITH AN960-616 AND
OR AN960-616L IF REQUIRED/AS REQUIRED.

COMPRESSOR
STAND-OFF PN 300067-1

SHIM P/N 261007(2 PLC'S)

COMP PIN PN 300095
WASHER AN960-516 OR
AN960-516L
NUT MS20364-524C OR
MS21042-5

2X BOLT AN4-14A
NUT MS21042-4 OR MS21042L4
WASHER AN960-616 AND OR
AN960-616L AS REQUIRED

UTILIZED WITH:

1. AS 350 WITH LATEST TRANSMISSION HOUSING DESIGN.

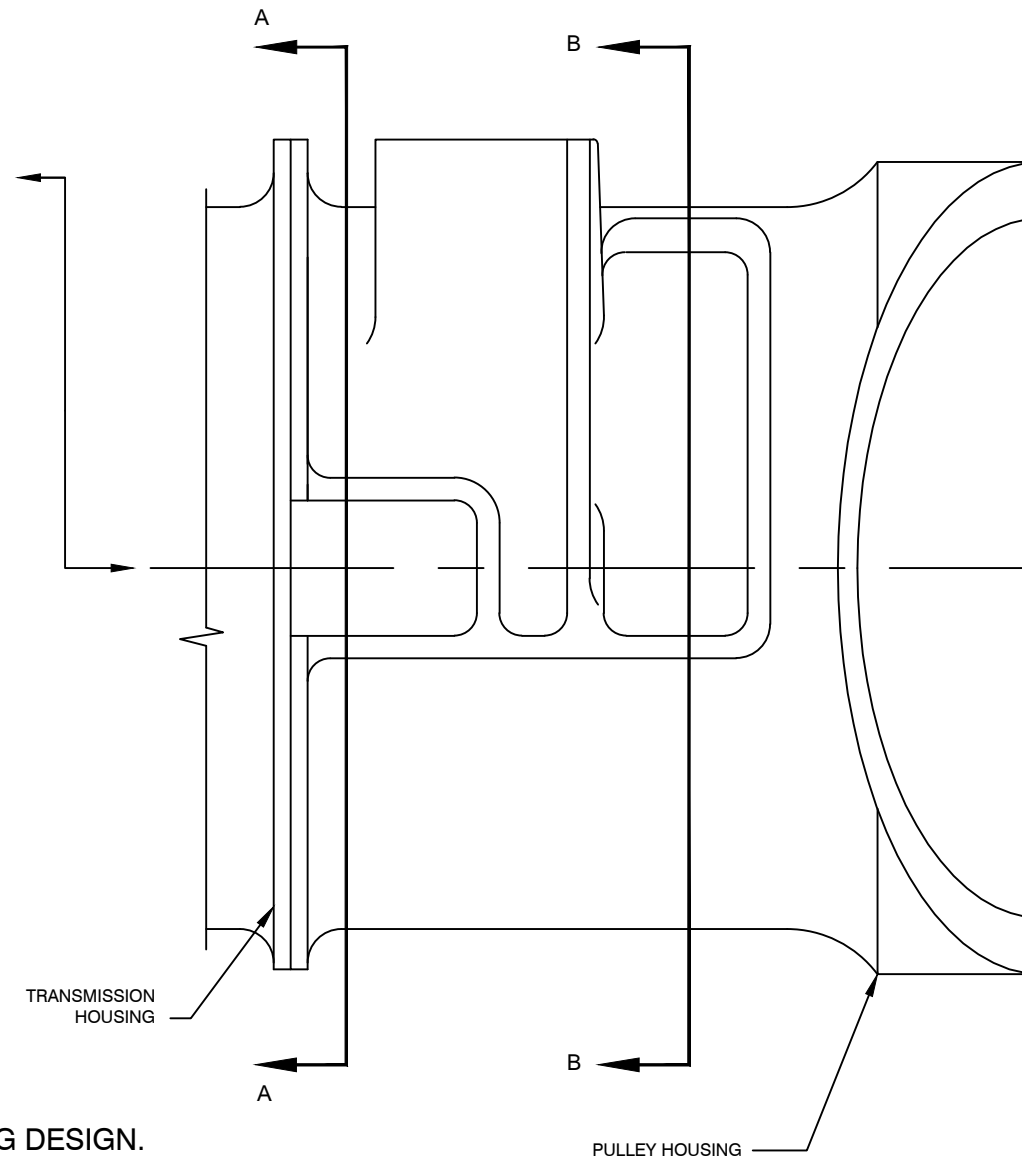

FORWARD
VIEW LOOKING INBOARD

VIEW C
REF 6-3-AS350

AFT

PROPRIETARY NOTICE TO ALL PERSONS RECEIVING THIS DOCUMENT THIS DOCUMENT AND INFORMATION OR TECHNICAL DATA AND DESIGNS CONTAINED HEREIN ARE PROPRIETARY DATA AND EXCLUSIVE PROPERTY OF RSG PRODUCTS INC. AND IS DELIVERED ON THE EXPRESS CONDITION THAT NEITHER THIS DOCUMENT NOR THE INFORMATION CONTAINED HEREIN SHALL BE DISCLOSED TO OTHERS, REPRODUCED IN WHOLE OR IN PART, OR USED FOR THE MANUFACTURE OR FABRICATION OF PARTS FOR ANYONE OTHER THAN RSG PRODUCTS INC. WITHOUT WRITTEN CONSENT AND AUTHORIZATION, AND THAT NO RIGHT IS GRANTED TO DISCLOSE OR SO USE ANY INFORMATION CONTAINED IN SAD DOCUMENT. THIS RESTRICTION DOES NOT LIMIT THE RIGHT TO USE INFORMATION OBTAINED FROM ANOTHER SOURCE.	NEXT ASSY.	TOLERANCES EXCEPT AS SHOWN		
	APPROVED BY:	.X: ±.1 .XX: ±.03 .XXX: ±.010 X.X": ±.5° BREAK ALL SHARP EDGES .01 ALL DIMENSIONS IN INCHES UNLESS OTHERWISE STATED		TITLE: COMPRESSOR INSTALLATION
		DATE:		DRAWN BY: JTYE DATE: 05/28/03 REV.: C SCALE: N/A SHEET: 1 OF 1
				APPLICATION: AS350 DWG. NO.: 6-13-AS350

INSTALLATION INSTRUCTIONS:

KIT P/N: 350-00-01, -011, -031, -011HP, AND -031HP

- 1) THE ABOVE KITS UTILIZE THE SANDEN SD-505 OR SD-507 COMPRESSOR (SEE DRAWING 350-00-011HP OR -031HP FOR DETAILS OF SD-507 INSTALLATION)..
- 2) IN EARLY 1997 IT WAS NOTICED BY AMERICAN EUROCOPTER AND LATER EUROCOPTER CANADA, LTD. THAT A FEW AS350 MODELS WERE ARRIVING WITH A DIFFERENT "ENGINE TO MAIN GEAR BOX COUPLING CASING", COMMONLY CALLED A "HOUSING", INSTALLED. THE PART NUMBER SHOWN IN THE EUROCOPTER IPC WAS: 350A35-1104-03. THIS COMPONENT HAS "EARS" EXTENDING OFF THE "HOUSING", ON BOTH SIDES, 37 mm IN LENGTH (SEE VIEW "A").

THE NEW "HOUSING " PART NUMBER IS 350A08-1635-21. IT HAS ONE EAR ON THE LEFT SIDE THAT IS ONLY 25 mm LONG.
(SEE VIEW "B")

THE 25 mm LONG EAR WILL NOT ALLOW AN INTEGRATED FLIGHT SYSTEMS, INC. SD-505 OR SD-507 COMPRESSOR TO BE INSTALLED IN ITS USUAL LOCATION.
- 3) THE "LOGICAL ANSWER" WAS TO LOCATE THE "MOUNTING POINT" OF THE COMPRESSOR(S) SO THAT A DIFFERENT LENGTH BELT, ETC. WOULD NOT BE REQUIRED..
- 4) ONLY TWO (2) PART CHANGES WERE REQUIRED TO ALLOW ITEM 3 TO OCCUR.
 - a. COMPRESSOR MOUNT ASSEMBLY 530027-1 WAS CHANGED TO -2 (.125 WIDER AT THE TOP MOUNTING POINT).
 - b. A NEW COMPONENT, NOT PREVIOUSLY USED, "STRAP, HOUSING MOD. ASSEMBLY", P/N: 530100 IS UTILIZED TO LOCATE THE COMPRESSOR MOUNTING POINT BACK TO ITS ORIGINAL LOCATION.
 - c. A AN3-5A BOLT AND ASSOCIATED HARDWARE SECURES THE "STRAP" TO THE "HOUSING".
- 5) IN SOME CASES IT MAY BE NECESSARY TO REMOVE A SMALL AMOUNT OF MATERIAL FROM THE OUTER EDGE OF THE 25 mm EAR TO ALLOW THE "NEW" IFS COMPONENT TO LAY IN ITS PROPER LOCATION. THIS IS DUE TO THE "SHIM" WELDED ON THE FORWARD SIDE OF THE COMPONENT WHICH ALLOWS ALIGNMENT TO THE COMPRESSOR EAR. ANY PAINT REMOVED FROM THE "HOUSING" EAR MUST BE TOUCHED UP BEFORE INSTALLING THE IFS PARTS.
- 6) IF AERO AIRE OR OTHER SIMILAR TYPE A/C COMPRESSOR HAS BEEN PREVIOUSLY INSTALLED PER VIEW "B" or "C", IT MAY BE NECESSARY TO FOLLOW THE STEPS IN ITEM 5 FOR CORRECT CLEARANCE.

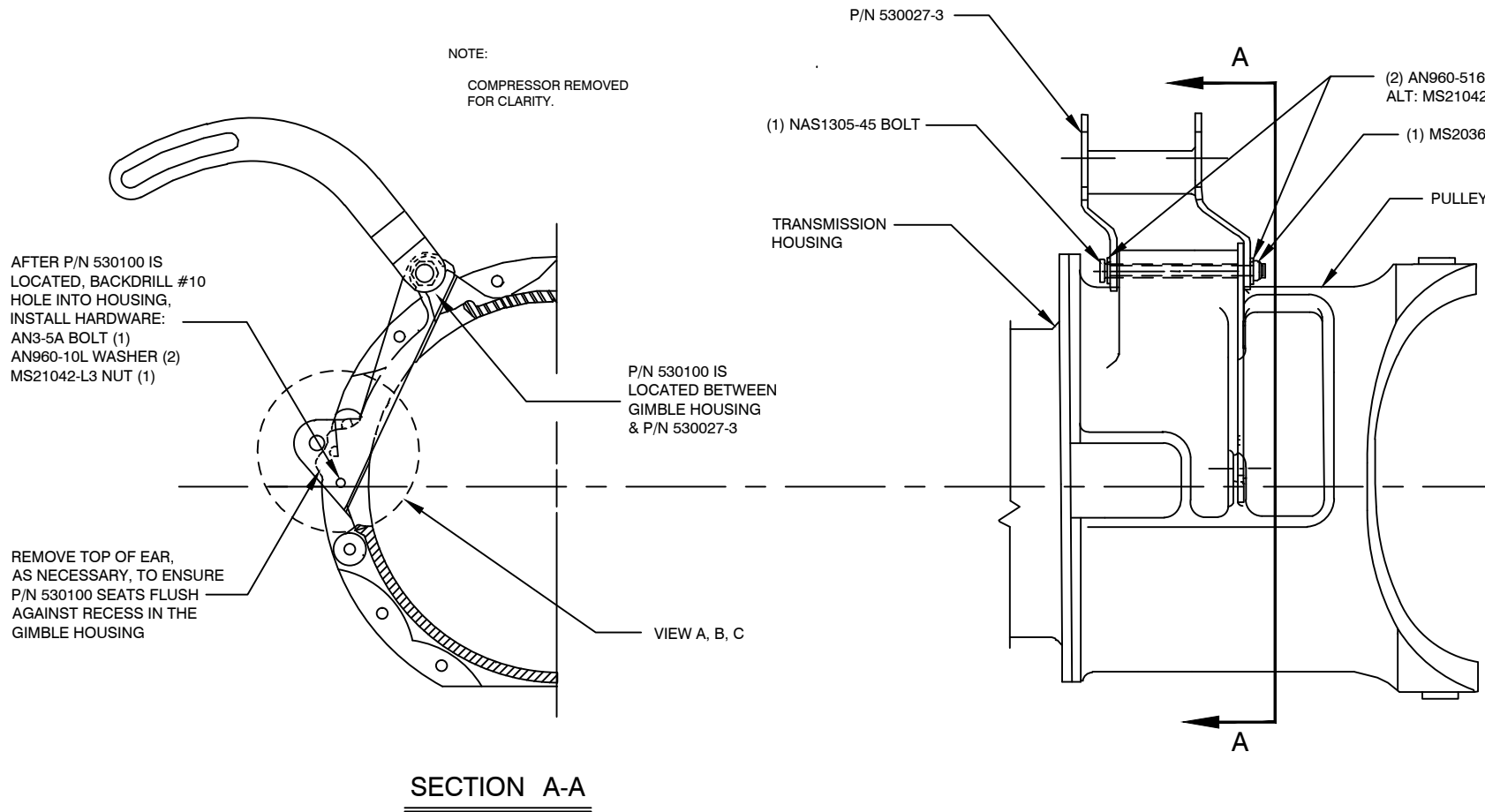

REVISION RECORD				
REV	DATE:	DESCRIPTION OF CHANGE	APPVD. BY	REV. BY
A	08/16/00	REDRAWN INTO AUTOCAD, REVISED DRAWING No. WAS 6-AS350; SHEET No. WAS 3 OF 3. ADDED ITEMS 6 TO "INSTRUCTIONS". CHANGED "CASING" TO "HOUSING". ADDED VIEW A, B AND C.		
B	05/08/02	REVISED TITLE BLOCK. CHANGED 530027-2 TO 530027-3. CONVERTED TO AUTOCAD.		
C	01/30/06	CHANGED NAS1305-44 BOLT TO NAS1305-45 FOR LENGTH.		JTYE
D	06/30/08	REVISED TITLE BLOCK.		JTYE
E	9/1/14	CHANGED TITLE BLOCK AND REVISION BLOCK.		AJC

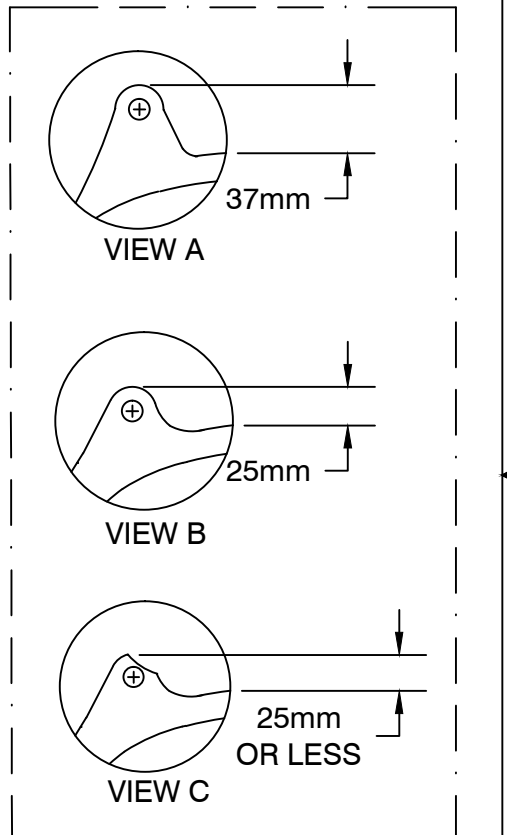

VIEW LOOKING INBOARD
← FORWARD →

<p>PROPRIETARY NOTICE</p> <p>TO ALL PERSONS RECEIVING THIS DOCUMENT THIS DOCUMENT AND INFORMATION OR TECHNICAL DATA AND DESIGNS CONTAINED HEREIN ARE PROPRIETARY DATA AND EXCLUSIVE PROPERTY OF RSG PRODUCTS INC. AND IS DELIVERED ON THE EXPRESS CONDITION THAT NEITHER THIS DOCUMENT NOR THE INFORMATION CONTAINED HEREIN SHALL BE DISCLOSED TO OTHERS, REPRODUCED IN WHOLE OR IN PART, OR USED FOR THE MANUFACTURE OR FABRICATION OF PARTS FOR ANYONE OTHER THAN RSG PRODUCTS INC. WITHOUT WRITTEN CONSENT AND AUTHORIZATION, AND THAT NO RIGHT IS GRANTED TO DISCLOSE OR SO USE ANY INFORMATION CONTAINED IN SAD DOCUMENT. THIS RESTRICTION DOES NOT LIMIT THE RIGHT TO USE INFORMATION OBTAINED FROM ANOTHER SOURCE.</p>	<p>NEXT ASSY.</p>	<p>TOLERANCES EXCEPT AS SHOWN</p> <p>.X: ±.1 .XX: ±.03 .XXX: ±.010 X.X°: ±.5° BREAK ALL SHARP EDGES .01 ALL DIMENSIONS IN INCHES UNLESS OTHERWISE STATED</p>		
	<p>APPROVED BY:</p>	<p>DATE:</p>		<p>TITLE: COMPRESSOR INSTALLATION</p>
	<p>DATE:</p>	<p>DATE:</p>	<p>DATE:</p>	<p>DRAWN BY: KLM</p> <p>DATE: 11/10/96</p> <p>REV.: E</p> <p>SCALE: N/A</p> <p>SHEET: 1 OF 1</p>
	<p>DATE:</p>	<p>DATE:</p>	<p>DATE:</p>	<p>APPLICATION: AS350</p> <p>DWG. NO.: 6-21-AS350</p>

REVISION RECORD				
REV	DATE	DESCRIPTION OF CHANGE	APPVD. BY	REV. BY
A	01/30/06	CHANGED NAS1305-44 BOLT TO NAS1305-45 FOR LENGTH. ADDED ALT. COMPRESSOR SHIMS. REMOVED BEVELED EDGE NOTATION FOR ALIGNMENT.		JTYE
B	06/30/08	REVISED TITLE BLOCK.		JTYE
C	9/1/14	CHANGED TITLE BLOCK AND REVISION BLOCK.		AJC

NOTE:
COMPRESSOR REMOVED FOR CLARITY.

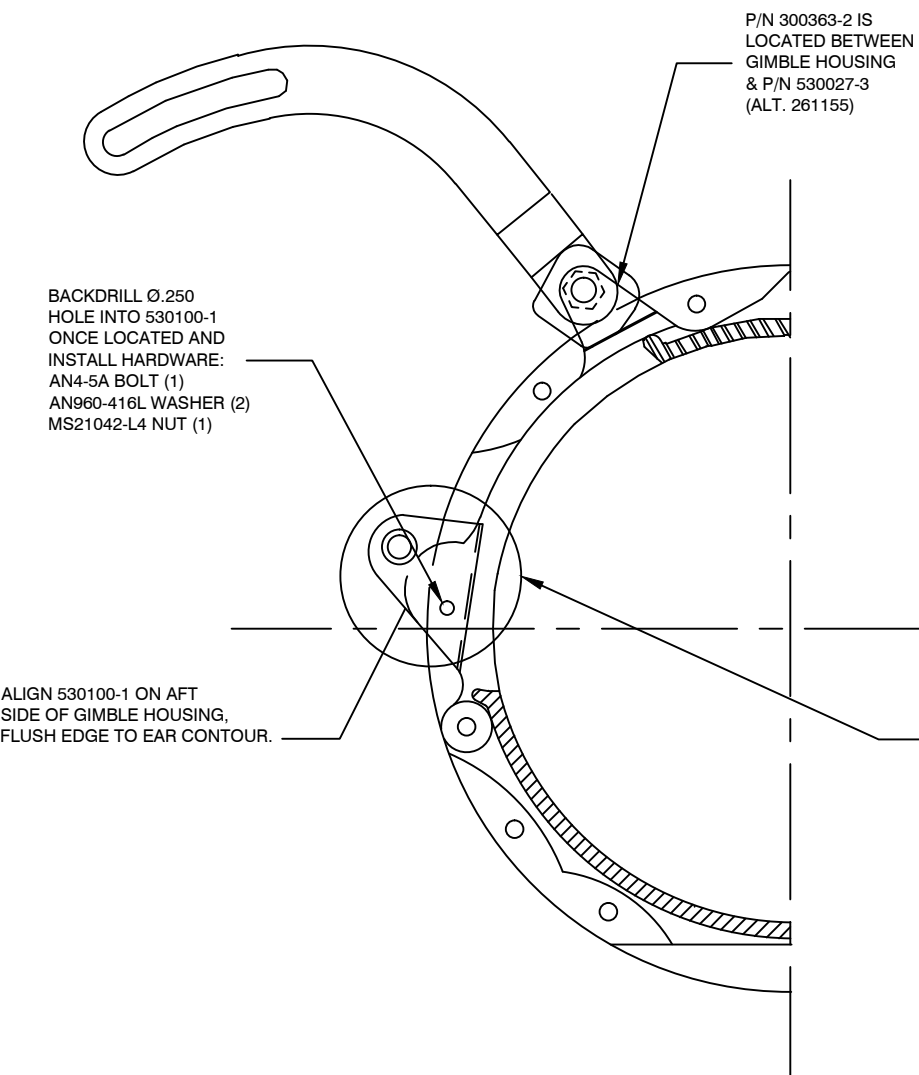

SECTION A-A

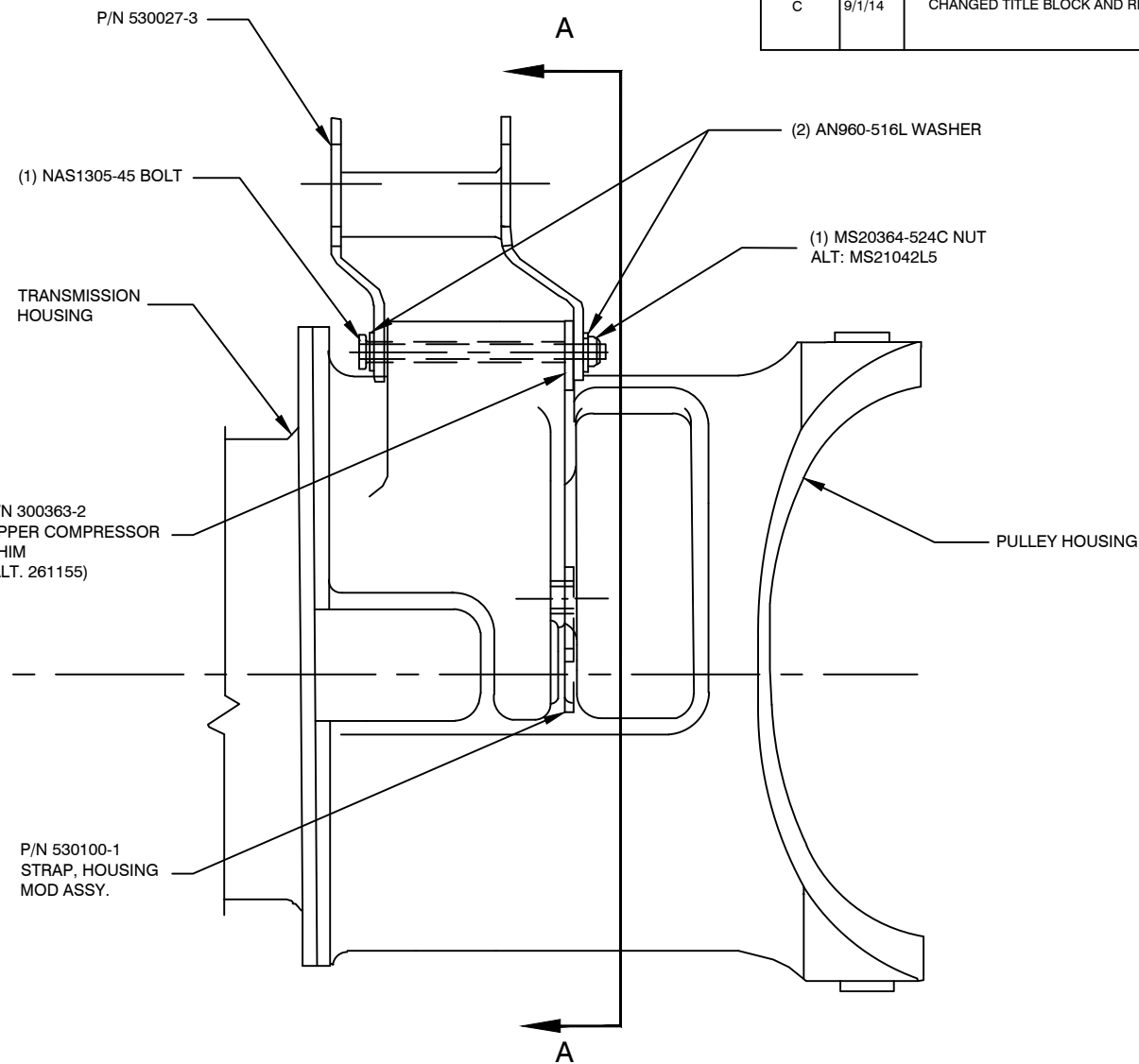

VIEW LOOKING INBOARD
FORWARD

UTILIZED WITH:

- AS 350 WITH LATEST TRANSMISSION HOUSING DESIGN.

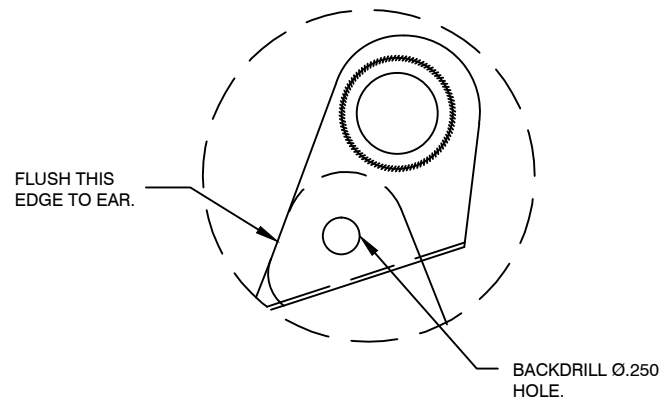

DETAIL A
NOT TO SCALE

PROPRIETARY NOTICE TO ALL PERSONS RECEIVING THIS DOCUMENT THIS DOCUMENT AND INFORMATION OR TECHNICAL DATA AND DESIGNS CONTAINED HEREIN ARE PROPRIETARY DATA AND EXCLUSIVE PROPERTY OF RSG PRODUCTS INC. AND IS DELIVERED ON THE EXPRESS CONDITION THAT NEITHER THIS DOCUMENT NOR THE INFORMATION CONTAINED HEREIN SHALL BE DISCLOSED TO OTHERS, REPRODUCED IN WHOLE OR IN PART, OR USED FOR THE MANUFACTURE OR FABRICATION OF PARTS FOR ANYONE OTHER THAN RSG PRODUCTS INC. WITHOUT WRITTEN CONSENT AND AUTHORIZATION, AND THAT NO RIGHT IS GRANTED TO DISCLOSE OR SO USE ANY INFORMATION CONTAINED IN SAD DOCUMENT. THIS RESTRICTION DOES NOT LIMIT THE RIGHT TO USE INFORMATION OBTAINED FROM ANOTHER SOURCE.	NEXT ASSY.	TOLERANCES EXCEPT AS SHOWN		
		.X: ±.1 .XX: ±.03 .XXX: ±.010 X.X°: ±.5° BREAK ALL SHARP EDGES .01 ALL DIMENSIONS IN INCHES UNLESS OTHERWISE STATED		TITLE: COMPRESSOR INTALLATION
	APPROVED BY:		DATE:	DRAWN BY: JTYE DATE: 05/28/03 REV.: C SCALE: N/A SHEET: 1 OF 1
				APPLICATION: AS350 DWG. NO.: 6-22-AS350

Step 9

Installation of Electrical

Installation of Electrical

STEP	PROCEDURE	MECH	INSP
9.1	Remove Battery Closeout panel. Re-position existing DZUS Receptacle Bracket on top of shelf, °180 to face down below shelf. Relocate Ng fuse on shelf (if installed) to existing hole near bottom of vertical channel. Relocate existing DZUS receptacle on the vertical support member 2” inches down, in order for upper shelf to clear when lowered for electrical panel installation/removal. Remove the (4) rivets that attach to the right end of the shelf to the vertical support member and enlarge the rivet holes on both the shelf and the vertical member to accept #10 hardware.		
9.2	Locate the electrical box, P/N 540028-C-1-A, on the support shelf and match drill three each #10 holes per drawing 2-19-AS350. Install the electrical box using three ea. AN3-4A Bolts, 3 ea. AN960-10 Washers. (Refer to drawing 7-2-AS350 for optional location of electrical box and components associated)		
9.3	Re-attach shelf using 4 ea. AN525-10R8 Screws, 8 ea. AN960-10 Washers and 4 ea. MS21044-N3 Nuts per drawing 2-19-AS350.		
9.4	Install and route the electrical harness: P/N 540044-3 config. -01 or -02, per drawings 2-19-AS350, 2-16-AS350 and 2-25-AS350.		
9.5	Install and route electrical harness P/N 540045-1 using 1 ea. 8 x #10 Ring Terminal and ANL-50 Limiter (not incl.).		
9.6	Install Instrument Panel Switch P/N 540044-8 config. -01 or -02, per drawing 5-26-AS350.		
9.7	Install aft switch assembly P/N 540089 config. -01 or -02, per drawings 5-10-AS350, 2-19-AS350, 2-16-AS350 and 2-25-AS350		

**Electrical Checkout Procedures
For The Air Conditioning System
Installation Manual for
350-00-031-HP
AEC Basic Version**

NOTE:

These procedures are to be performed upon completion of **STEPS 9.1 thru 9.7** as instructed in **Section 9** of the **Installation Manual 350-00-031-HP** and after all wiring has been verified (rang out) from point to point using an ohm meter.

This test is to only be performed prior to charging air conditioner with Freon. **If unit is charged, skip step 7 and go onto step 8.**

All power is removed from aircraft until directed to do so.

At the time of this writing, units are now installed with a 50 AMP fuse and not a 50 AMP circuit breaker as depicted in the drawing.

REFFERANCE DRAWINGS:

ELECTRICAL ROUTING 2-19-AS350

ELECTRICAL DIAGRAM 2-16-AS350 (For Dual Condenser Blower installation Sheet 1)

ELECTRICAL DIAGRAM 2-25-AS350 (For Dual Condenser Blower installation Sheet 1 and 2)

EQUIPMENT REQUIRED:

PORTABLE VOLT/OHM METTER
20 AWG JUMPER WIRES,

ELECTRICAL TEST:

- 1) Locate and disconnect connectors **CP100** from the **Electrical Box Assembly** located in the aft cargo bay as depicted on drawing **2-19-AS350**.
- 2) Ensure that the **50 AMP** fuse, located on the existing **Master Electrical Panel** is de-energized and that all circuit breakers (**15,20, and 1 AMP**) on the **Electrical Box Assembly** PN. **540028-C-2-A** are de-energized.
- 3) Apply power to the aircraft. Using the Volt/Ohm meter, verify that contact **#1** of **CP100** has 0 volts DC.
- 4) Remove power from the aircraft. Energize the **50 AMP** fuse, located on the existing **Master Electrical Panel**. Return power to the aircraft and verify that contact **#1** of **CP100** now has 28 VDC.

- 5) Remove power from the aircraft, de-energize the **50 AMP** fuse and re-connect connector **CP100**.
- 6) Energize the **50 AMP** fuse. Ensure that the **Air Conditioner Master** (part number **540044-8-02** assembly mounted in cockpit) **Power Switch** is in the “**OFF**” position and that the **5 AMP** circuit breaker is de-energized. Apply power to the aircraft.
- 7) **Perform this step on non-charged units. If charged, go to step 8.** Locate the **Low Pressure** switch (p/n 050107) and the **High Pressure** switch (p/n 090004). Using jumper wires, bypass both the **Low Pressure** switch and **High Pressure** switch by attaching a jumper lead to each connecting terminals; one for the **Low Pressure** switch and another for the **High Pressure** switch. Apply power to the aircraft.
- 8) Energize both condenser **20 AMP** circuit breakers and **1 AMP** circuit breaker on the **Electrical Box Assembly**. Energize the **5 AMP** breaker on the **Air Conditioner Master Panel** and place the **Master Air Conditioner** switch to the “**ON**” position. Verify that the **Air Conditioner Compressor** clutch engages.
- 9) Energize the **15 AMP** evap circuit breaker, both condenser **20 AMP** circuit breakers, **20 AMP** evap circuit breaker, and **1 AMP** circuit breaker on the **Electrical Box Assembly**. Verify that the **Forward Fan Motor** for the evaporator is “**ON**” and that the speed can be controlled using the **Hi/Lo** switch on the **Air Conditioner Master Panel**. Verify that the **Condenser Blower** motor comes “**ON**” after approximately 15 seconds.
- 10) Verify that the **Fan Motor** speeds on **AFT Evaporator Fan Motor** (using the **AFT SWITCH**) and the **FORWARD Evaporator Fan Motor** (using the **FORWARD SWITCH**) work correctly.
- 11) Place the **Master Air Conditioner Switch** to the “**OFF**” position and de-energize the **5 AMP** breaker on the **Air Conditioner Master Panel**. Remove power to the aircraft. De-energize the **15 AMP** evap circuit breaker, both condenser **20 AMP** circuit breakers, **20 AMP** evap circuit breaker, **1 AMP** circuit breaker and **50 AMP** fuse. Remove the jumpers installed on the **High Pressure** and **Low Pressure** switches.

NOTE: If equipped with a Vehicle & Engine Management Display (VEMD), the "Penalty" needs to be set for RFMS section 5.0, Performance Data.

NOTES:

USE EXISTING LIGHTENING HOLES ONLY FOR ALL ROUTING OR SECURE WIRES TO EXISTING BUNDLES OR REFRIGERATION HOSE USING TY-WRAPPS, STAND-OFFS, AND SPACERS BLOCKS AS REQUIRED.

1. LOCATION OF PRESSURE SWITCHES WHEN R-134a IS UTILIZED.
2. ON B3 MODELS IFS WIRE ROUTING MUST BE ACCORDANCE WITH THIS DRAWING.
3. INSTALL IFS104C14 TO LOW PRESSURE SWITCH. (BLUE LEADS)
4. INSTALL IFS108B20 AND IFS108D20 TO HIGH PRESSURE SWITCH. (BLACK LEADS)
5. REMOVE BATTERY CLOSEOUT PANEL. REPOSITION EXISTING DZUS RECEPTACLE BRACKET ON TOP OF SHELF, 180 DEGREES TO FACE DOWN BELOW SHELF.
6. RELOCATE Ng FUSE ON SHELF (IF INSTALLED) TO EXISTING HOLE NEAR BOTTOM OF VERTICAL CHANNEL. RELOCATE EXISTING DZUS RECEPTACLE ON THE VERTICAL SUPPORT MEMBER 2 INCHES DOWN, IN ORDER FOR UPPER SHELF TO CLEAR WHEN LOWERED FOR ELECTRICAL BOX INSTALLATION/REMOVAL.
7. REMOVE THE (4) RIVETS THAT ATTATCH TO THE RIGHT END OF SHELF TO VERTICAL SUPPORT MEMBER. ENLARGE RIVET HOLES ON FRONT END OF SHELF AND VERTICAL SUPPORT TO ACCOMMODATE #10 FASTENERS. LOCATE ELECTRICAL PANEL ON SHELF AND BACK DRILL THREE (3) EACH #10 HOLES TO MATCH NUT PLATE ON BOTTOM OF ELECTRICAL PANEL ASSEMBLY.
8. ATTACH ELECTRICAL PANEL ASSEMBLY TO SHELF USING AN3-4A BOLT AND AN960-10 WASHER, IN THREE (3) PLACES.
9. REATTACH END OF SHELF TO VERTICAL SUPPORT USING AN525-10R8 SCREW, AN960-10 WASHER, AND MS21044-N3 NUT IN FOUR (4) PLACES.
10. CUT CLOSEOUT PANEL LEVEL WITH THE TOP OF THE UPPER SHELF. RELOCATE DZUS FASTENERS TO MATCH NEW LOCATION OF DZUS RECEPTALS. REINSTALL CLOSEOUT PANEL. ROUTE AND SUPPORT WIRING HARNESSES IAW AC43.13-1B, CHAPTER 11 SECTION 8, PARAGRAPH 11-96.
11. CLAMP WIRING HARNESS IAW AC43.13-1B, CHAPTER 11, SECTION 11, PARAGRAPH 11-146.
12. CLAMP AND ROUTE WIRES AROUND MOVABLE CONTROLS IAW AC43.13-1B, CHAPTER 11, SECTION 9, PARAGRAPH 11-125.
13. WIRING AND HARNESS TO BE SEPARATED IAW AC43.13-1B, CHAPTER 11, SECTION 8, PARAGRAPH 11-105 AND 11-106.
14. INSTALL SERVICE LOOPS AT HARNESS TERMINATIONS IAW AC43.13-1B, CHAPTER 11, SECTION 9, PARAGRAPH 11-139.
15. INSTALL GROUNDING CONNECTION AND BONDING IAW AC43.13-1B, CHAPTER 11, SECTION 15, PARAGRAPH 11-186 AND 11-189.
16. COVER ALL KNIFE CONNECTOR CONNECTIONS WITH PROPER HEATSHRINK TUBING SIZE. HEATSHRINK TUBING TO BE SECURED WITH LACING CORD OR SMALL TIE WRAPS. WHEN INSTALLING ON B3 E MODEL REFER TO OPTIONAL LOCATION FOR ELECTRICAL CONTROL BOX & COMPONENTS ASSOCIATED SHOWN ON DRAWING No. 7-2-AS350 SHEET 3 OF 3.

REVISION RECORD

REV	DATE:	DESCRIPTION OF CHANGE	APPVD. BY	REV. BY
A	06/15/03	DWG. NUMBER WAS 2-7-AS350. IS NOW 2-19-AS350.		
B	03/31/09	CHANGED AFT TRANSITION ELBOW PN: 520036-2 TO ALTERNATE, 520036-3 IS NOW PRIMARY. ADDED ALT. RESISTOR ASSEMBLY PN: 540020. REVISED TITLE BLOCK.		
C	09/01/14	CHANGED TITLE BLOCK AND REVISION BLOCK. INCORPORATED ECO 0284 & 0711.		AJC
D	01/19/22	REMOVE RESISTOR & ASSOCIATED COMPONENTS. ADDED & REMOVED PART NUMBERS TO NOTE CALL OUTS. UPDATED L,H FORWARD AIR OUTLETS. ADDED NOTES 11-17. ADDED FLAG NOTE 18 TO NOTE SECTION & VIEW PER ECO'S 0765 & 0815.		SGB

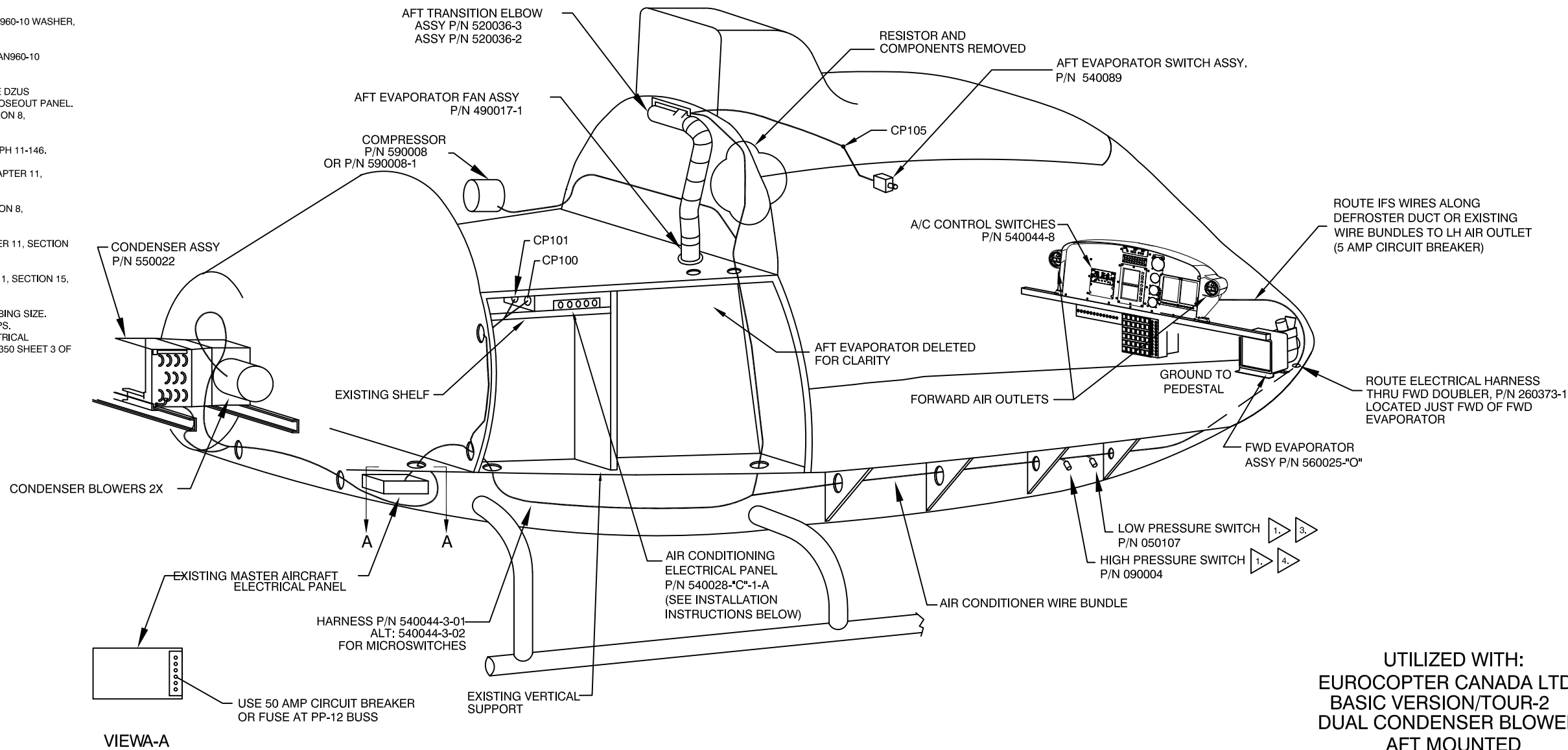

UTILIZED WITH:
EUROCOPTER CANADA LTD
BASIC VERSION/TOUR-2
DUAL CONDENSER BLOWER
AFT MOUNTED

<p>PROPRIETARY NOTICE</p> <p>TO ALL PERSONS RECEIVING THIS DOCUMENT THIS DOCUMENT AND INFORMATION OR TECHNICAL DATA AND DESIGNS CONTAINED HEREIN ARE PROPRIETARY DATA AND EXCLUSIVE PROPERTY OF RSG PRODUCTS INC. AND IS DELIVERED ON THE EXPRESS CONDITION THAT NEITHER THIS DOCUMENT NOR THE INFORMATION CONTAINED HEREIN SHALL BE DISCLOSED TO OTHERS, REPRODUCED IN WHOLE OR IN PART, OR USED FOR THE MANUFACTURE OR FABRICATION OF PARTS FOR ANYONE OTHER THAN RSG PRODUCTS INC. WITHOUT WRITTEN CONSENT AND AUTHORIZATION, AND THAT NO RIGHT IS GRANTED TO DISCLOSE OR SO USE ANY INFORMATION CONTAINED IN SAID DOCUMENT. THIS RESTRICTION DOES NOT LIMIT THE RIGHT TO USE INFORMATION OBTAINED FROM ANOTHER SOURCE.</p>	<p>NEXT ASSY.</p>	<p>TOLERANCES EXCEPT AS SHOWN</p> <p>.X: ±.1 .XX: ±.03 .XXX: ±.010 X.X": ±.5" BREAK ALL SHARP EDGES .01 ALL DIMENSIONS IN INCHES UNLESS OTHERWISE STATED</p>	<p>RSG PRODUCTS INC. A ROTORCRAFT SERVICES GROUP COMPANY</p>			
	<p>APPROVED BY:</p>	<p>DATE:</p>		<p>DATE:</p>		
<p>TITLE: ELECTRICAL ROUTING</p>		<p>DRAWN BY: JTJE</p>	<p>DATE: 08/19/02</p>	<p>REV.: D</p>	<p>SCALE: N/A</p>	<p>SHEET: 1 OF 1</p>
<p>APPLICATION: AS350</p>		<p>DWG. NO.:</p>		<p>2-19-AS350</p>		

NOTES:

- ALL WIRE MIL-W-22759/16.
ALL WIRE 14ga UNLESS OTHERWISE SPECIFIED.
- FUSES MAY BE USED, P/N 100FU01-050 (50AMP).
- LOCATE #8 WIRE AT T4, T5, T6, OR T7 (INSTALL 50 AMP FUSE IF NOT PRESENT, SEE NOTE 2)
- WHEN ALL EUROCOPTER FUSES OR C/B LOCATIONS ARE UTILIZED, A "AUX" CURRENT LIMITER BASE P/N FU1541-501, BRACKET/SUPPLY BAR AND CURRENT LIMITER MAY BE INSTALLED AT F9 OR F10 PER EUROCOPTERS COMPONENT MAINTENANCE MANUAL. IFS P/N FOR LIMITER BASE IS 050023. IFS P/N FOR LIMITER, 50 AMP IS 050015-2.
- RFI CORP. EMI FILTER MODEL NUMBER 13619-RF16883.
- FOR BACKLIGHTING, MODELS B2/B3, CONNECT TO 131-L1, ANY AVAILABLE PIN.
- ROUTE AND SUPPORT WIRING HARNESSES IAW AC43.13-1B, CHAPTER 11 SECTION 8, PARAGRAPH 11-96.
- CLAMP WIRING HARNESS IAW AC43.13-1B, CHAPTER 11, SECTION 11, PARAGRAPH 11-146.
- CLAMP AND ROUTE WIRES AROUND MOVABLE CONTROLS IAW AC43.13-1B, CHAPTER 11, SECTION 9, PARAGRAPH 11-125.
- WIRING AND HARNESS TO BE SEPARATED IAW AC43.13-1B, CHAPTER 11, SECTION 8, PARAGRAPH 11-105 AND 11-106.
- INSTALL SERVICE LOOPS AT HARNESS TERMINATIONS IAW AC43.13-1B, CHAPTER 11, SECTION 9, PARAGRAPH 11-139.
- INSTALL GROUNDING CONNECTION TO THE CHASSIS AND BONDING IAW AC43.13-1B, CHAPTER 11, SECTION 15, PARAGRAPH 11-186 AND 11-189.
- COVER ALL KNIFE CONNECTOR CONNECTIONS WITH PROPER HEATSHRINK TUBING SIZE. HEATSHRINK TUBING TO BE SECURED WITH LACING CORD OR SMALL TIE WRAPS.

REVISION RECORD

REV	DATE	DESCRIPTION OF CHANGE	APPVD. BY	REV. BY
A	05/10/99	ADDED ALTERNATE BLOWER, IFS P/N 050143. EVAP BREAKER WAS 15 AMP, IS 20. ADDED NOTES 4, 5, & 6. CHANGED LOCATION OF "LOW" SWITCH. WAS PP-2, IS PP-12		
B	08/16/00	REVISED DRAWING NUMBER, WAS 2-AS 350; SHEET NUMBER WAS 2 OF 3. CHANGED NOTE 1. NOTE 2 WAS NOTE 5. NOTE 3 WAS NOTE 6 ADDED NOTE 4. DELETED NOTE 2. ADDED ALTERNATE BLOWER P/N 050180.		
C	03/18/01	CONVERTED TO AUTOCAD.		
D	01/03/07	ADDED ALTERNATE RESISTOR ASSY PN: 540020. IS SAME RESISTOR WITH PRE LABELED LEADS. REDRAWN TO REFLECT AS350 INSTALLATION, PREVIOUSLY DRAWN FOR AS355. CHANGED TITLE BLOCK.		
E	03/31/09	REMOVED ALTERNATE BLOWER P/N 050180, ADDED LISTING OF INTERCHANGEABLE BLOWERS. ADDED JUMPER CONFIGURATION NOTATION. REVISED TITLE BLOCK.		
F	09/01/14	REVISED TITLE BLOCK AND REVISION BLOCK. INCORPORATED ECO# 0285		AJC
G	01/19/22	REVISED NOTES & UPDATED WIRING LAYOUT FOR THE USE OF MICROSWITCHES & BRUSHLESS AFT MOTORS. REMOVED RESISTOR & ADDED OPTIONAL EMI FILTERS PER ECO 1023.		SGB

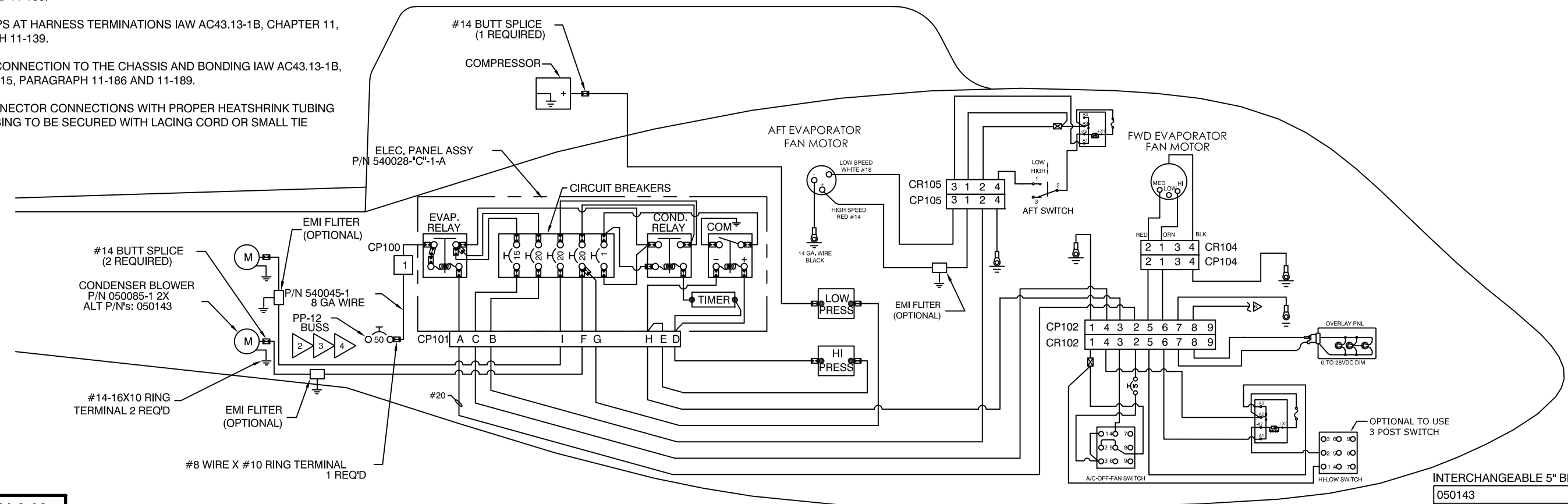

For installation of 540044-8-02:
If AC control panel is relocated from the I-panel to the console then the dimming wire must also be relocated. Relocate wire IFS111C20 from the 131L1 Module to 133L3M1-E or any available location within the M1 module. Add a resistor (suggested value 3.3k ohm 1/2 W) as required to achieve proper lighting balance.

AS350
ELECTRICAL WIRING DIAGRAM
DUAL CONDENSER BLOWERS
AFT MOUNTED

PROPRIETARY NOTICE
TO ALL PERSONS RECEIVING THIS DOCUMENT THIS DOCUMENT AND INFORMATION OR TECHNICAL DATA AND DESIGNS CONTAINED HEREIN ARE PROPRIETARY DATA AND EXCLUSIVE PROPERTY OF RSG PRODUCTS INC. AND IS DELIVERED ON THE EXPRESS CONDITION THAT NEITHER THIS DOCUMENT NOR THE INFORMATION CONTAINED HEREIN SHALL BE DISCLOSED TO OTHERS, REPRODUCED IN WHOLE OR IN PART, OR USED FOR THE MANUFACTURE OR FABRICATION OF PARTS FOR ANYONE OTHER THAN RSG PRODUCTS INC. WITHOUT WRITTEN CONSENT AND AUTHORIZATION, AND THAT NO RIGHT IS GRANTED TO DISCLOSE OR SO USE ANY INFORMATION CONTAINED IN SAID DOCUMENT. THIS RESTRICTION DOES NOT LIMIT THE RIGHT TO USE INFORMATION OBTAINED FROM ANOTHER SOURCE.

NEXT ASSY.
TOLERANCES EXCEPT AS SHOWN
.X: ±.1
.XX: ±.03
.XXX: ±.010
X.X: ±.5"
BREAK ALL SHARP EDGES .01
ALL DIMENSIONS IN INCHES UNLESS OTHERWISE STATED
DATE:
APPROVED BY:

RSG PRODUCTS INC.
A ROTORCRAFT SERVICES GROUP COMPANY

TITLE:
ELECTRICAL DIAGRAM

DRAWN BY: MAH	DATE: 11/10/96	REV.: G	SCALE: N/A	SHEET: 1 OF 1
APPLICATION: AS350			DWG. NO.: 2-16-AS350	

INTERCHANGEABLE 5" BLOWERS

050143
050085-1
IFSS 050143 DCB
IFSS 050143-3 DCB

- NOTES:
- SEE 2-5-AS350 SH 1 OF 1 FOR WIRE SPLICE LOC.
 - WIRE SPEC. MIL-W-22759/16.
 - RFI CORPORATION EMI FILTER MODEL NUMBER 13619-RF16883.
 - FOR BACKLIGHTING, MODELS B2/B3, CONNECT TO 131-L1, ANY AVAILABLE PIN.
 - ROUTE AND SUPPORT WIRING HARNESSES IAW AC43.13-1B, CHAPTER 11, SECTION 8, PARAGRAPH 11-96.
 - CLAMP WIRING HARNESS IAW AC43.13-1B, CHAPTER 11, SECTION 11, PARAGRAPH 11-146.
 - CLAMP AND ROUTE WIRES AROUND MOVABLE CONTROLS IAW AC43.13-1B, CHAPTER 11, SECTION 9, PARAGRAPH 11-125.
 - WIRING HARNESS TO BE SEPARATED IAW AC43.13-1B, CHAPTER 11, SECTION 8, PARAGRAPH 11-105 AND 11-106.
 - INSTALL SERVICE LOOPS AT HARNESS TERMINATIONS IAW AC43.13-1B, CHAPTER 11, SECTION 9, PARAGRAPH 11-139.

- INSTALL GROUNDING CONNECTION AND BONDING IAW AC43.13-1B, CHAPTER 11, SECTION 15, PARAGRAPH 11-186 AND 11-189.
- COVER ALL KNIFE CONNECTOR CONNECTIONS WITH PROPER HEATSHRINK TUBING SIZE. HEATSHRINK TUBING TO BE SECURED WITH LACING CORD OR SMALL TIE WRAPS.

REVISION RECORD				
REV	DATE	DESCRIPTION OF CHANGE	APPVD. BY	REV. BY
A	5/10/99	WAS PP-2 BUSS, IS PP-12 BUSS. EVAP BREAKER WAS 15 AMP, IS 20 AMP. CHANGED LOCATION OF LOW PRESSURE SWITCH.		
B	6/16/00	REVISED DRAWING NUMBER. WAS 2-AS350. SHEET NUMBER WAS 3 OF 3.		
C	3/24/01	CONVERTED TO AUTOCAD.		
D	5/10/99	REDRAWN FOR CLARITY. PRESSURE SWITCHES NOW SHOWN IN CLOSED POSITION. CP103 JUMPER NOTATION ADDED. REVISED TITLE BLOCK.	MLD	JTYE
E	9/1/14	ADDED EMI FILTERS TO CONDENSERS AND AFT EVAP. CHANGED WIRE GAUGES. ADDED SPLICES, ADDED RELAYS FOR MICROSWITCHES PER ECO # 0699.		SJ
F	01/19/22	SHEET 1 OF 2: ADDED NOTES 5-11 TO MEET AC43.13-1B. SHEET 2 OF 2: REMOVE RESISTOR & COMPONENTS ASSOCIATED WITH IT. REVISE CALLOUT NOTES BY ADDING, REMOVING OR UPDATE P/N'S. UPDATE L.H. FORWARD AIR OUTLETS. WIRES "IFS111C14" & "IFS111B14" WILL NOW BE "IFS111C20" & "IFS111B20".		SGB

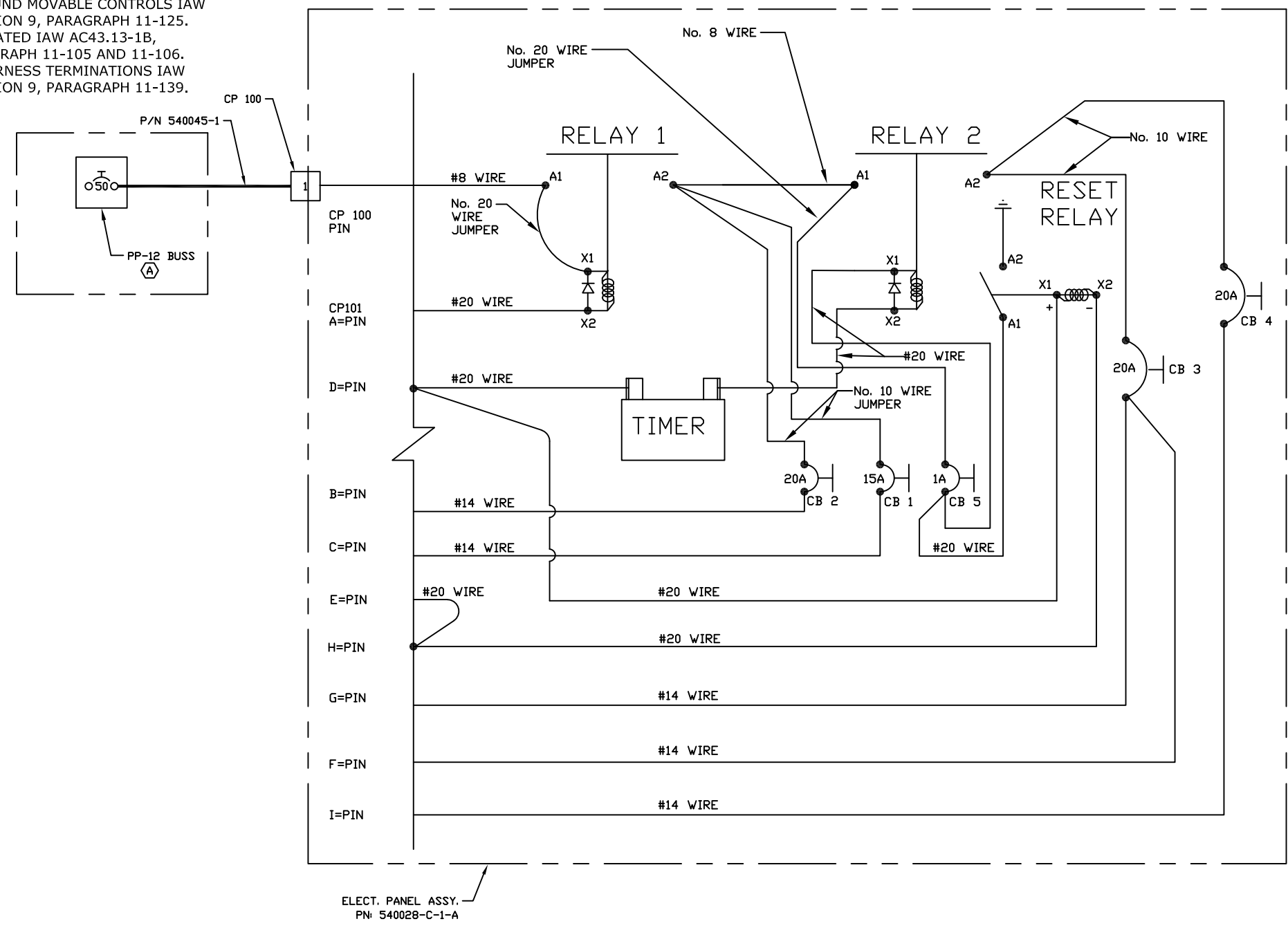

AS350
ELECTRICAL WIRING DIAGRAM
DUAL CONDENSER BLOWER

PROPRIETARY NOTICE

TO ALL PERSONS RECEIVING THIS DOCUMENT THIS DOCUMENT AND INFORMATION OR TECHNICAL DATA AND DESIGNS CONTAINED HEREIN ARE PROPRIETARY DATA AND EXCLUSIVE PROPERTY OF RSG PRODUCTS INC. AND IS DELIVERED ON THE EXPRESS CONDITION THAT NEITHER THIS DOCUMENT NOR THE INFORMATION CONTAINED HEREIN SHALL BE DISCLOSED TO OTHERS, REPRODUCED IN WHOLE OR IN PART, OR USED FOR THE MANUFACTURE OR FABRICATION OF PARTS FOR ANYONE OTHER THAN RSG PRODUCTS INC. WITHOUT WRITTEN CONSENT AND AUTHORIZATION, AND THAT NO RIGHT IS GRANTED TO DISCLOSE OR SO USE ANY INFORMATION CONTAINED IN SAID DOCUMENT. THIS RESTRICTION DOES NOT LIMIT THE RIGHT TO USE INFORMATION OBTAINED FROM ANOTHER SOURCE.

NEXT ASSY.

TOLERANCES EXCEPT AS SHOWN

.X: ±.1
 .XX: ±.03
 .XXX: ±.010
 X.X: ±.5"
 BREAK ALL SHARP EDGES .01
 ALL DIMENSIONS IN INCHES UNLESS OTHERWISE STATED

DATE:

APPROVED BY:

PRODUCTS INC.
 A ROTORCRAFT SERVICES GROUP COMPANY

TITLE:
ELECTRICAL DIAGRAM

DRAWN BY: MAH	DATE: 11/10/96	REV.: F	SCALE: N/A	SHEET: 1 OF 2
APPLICATION: AS350			DWG. NO.: 2-25-AS350	

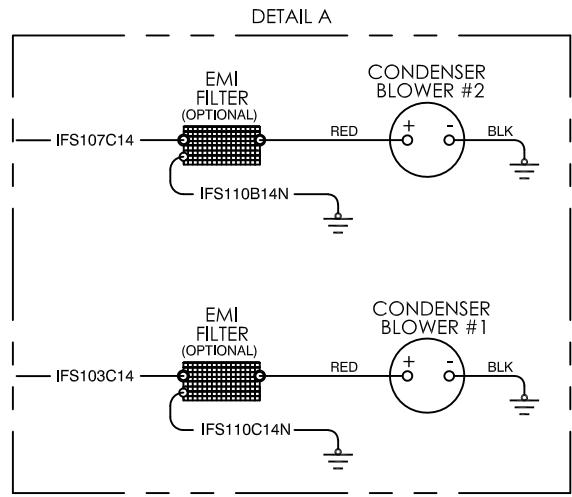
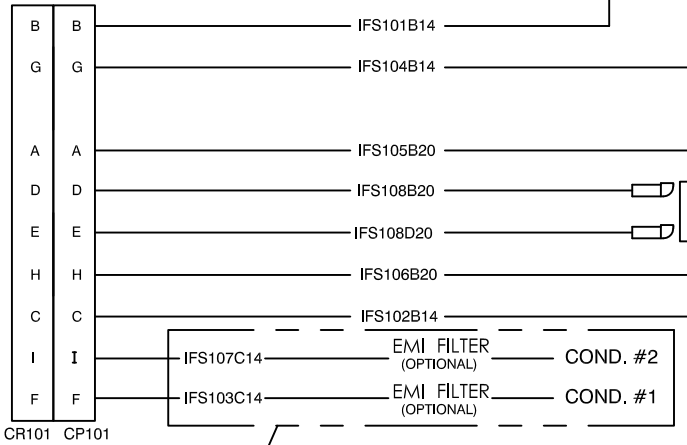
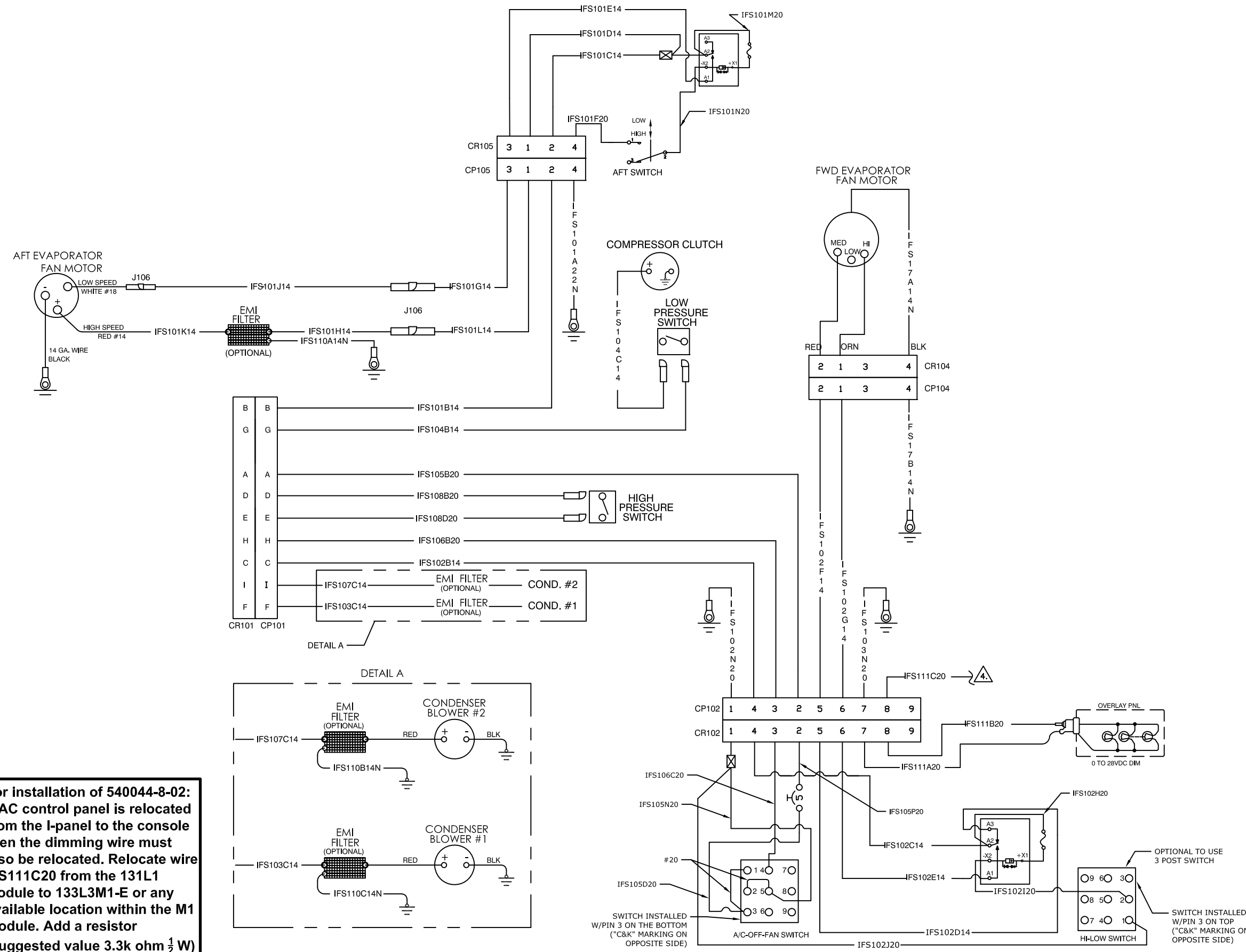

For installation of 540044-8-02:
 If AC control panel is relocated from the I-panel to the console then the dimming wire must also be relocated. Relocate wire IFS111C20 from the 131L1 Module to 133L3M1-E or any available location within the M1 module. Add a resistor (suggested value 3.3k ohm 1/2 W) as required to achieve proper lighting balance.

PRODUCTS INC.
 A ROTORCRAFT SERVICES GROUP COMPANY

TITLE: **ELECTRICAL DIAGRAM**

DRAWN BY: MAH	DATE: 11/10/96	REV.: F	SCALE: N/A	SHEET: 2 OF 2
APPLICATION: AS350			DWG. NO.: 2-25-AS350	

INSTRUCTIONS:

1. PLACE MOUNTING CHANNEL AS HIGH AS POSSIBLE. INSPECT FOR EXISTING RIVETS THAT MIGHT HOLD CHANNEL OFF DECK.
2. TRIM/NOTHC CHANNEL AROUND RIVETS.
3. RE-FIT BEFORE MATCH DRILLING AS IN (4).
4. MATCH DRILL COND. FAN MT CHAN TO EXISTING MOUNT ANGLE INSTALL RIVETS CR 3243-4-X

5. TRIM ELBOW FLANGE AS NECESSARY TO ACCOMMODATE CONTROL BOX ON BRUSHLESS MOTORS.
6. NOTE: FOR -031 A/C CONFIG KIT; FABRICATE CIRCULAR COVER WITH .040 THK 2024-T3 TO CLOSE OUT HOLE UTILIZED FOR -011 CONFIG. A/C KIT FOR BLOWER MOTOR MOUNT LOCATION.

RELOCATE FASTENER TO LOWER RIGHT. (SEE 8-11-AS350, SHEET 1 OF 1, BAGGAGE COMPARTMENT MOD FOR ACTUAL LOCATION)

AN3-5A(3)
AN960-10(6)
MS21044-N3(3)
LOCATE NUT ON FWD SIDE

AN3-3A(5)
AN960-10(10)
AN365-1032(5)
ALT NUT MS21044-N3
OR OEM SECONDARY
BATTERY SHELF HARDWARE

BAT COMP SHELF PN 260333
OR OEM SECONDARY BATTERY SHELF

RELOCATE FASTENERS TO
MATCH COMPARTMENT COVER
(TYP 2 PL)

16.5 FLOOR

REINSTALL EXISTING BATTERY SHELF

ADD FILLER
PN 260862

CONDENSER EXH ELBOW ASSY
PN 520032-1 (TRIM EX. ELBOW
TO FIT AROUND CONTROL BOX
ON BRUSHLESS MOTOR)

8" BAND CLAMP

SCREW AN 507-1032 R10(6)
WASHER AN 960-10(6)
NUT MS21044-N3(6)

CONDENSER FAN PN 050084
ALT BLOWER PN 050084-6
ALT BLOWER PN IFSS 050084-7-2

NAS 603-12P SCREW(4)
AN 960-10 WASHER(4)
ALT: NAS620-10 WASHER(4)
REQUIRED WITH IFSS 050084-7-2, IFSS050084-7-3

BAT COMP SHELF ANG FWD
PN 260335

RIVET CR 3243-4-3(4)

COND FAN MTG CHANNEL
PN 260148 OR -3
REPLACES AEROSPATILE
ASSY 2105000001

MATCH EXISTING HOLES
IN BATTERY SUPPORT AND
INSTALL EXISTING HARDWARE

HOLE FOR EXISTING CIRCUIT BREAKER
OR FUSE(ENLARGE, AS REQUIRED)

COND DRAIN HOLE

BACK DRILL INSTALL W/
MS20470 AD4-AR

STATION 140.2

FAN CHANNEL BASE
ANGLE PN 260020

RIGHT BAGGAGE COMPARTMENT

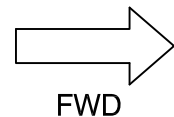

<p>PROPRIETARY NOTICE</p> <p>TO ALL PERSONS RECEIVING THIS DOCUMENT THIS DOCUMENT AND INFORMATION OR TECHNICAL DATA AND DESIGNS CONTAINED HEREIN ARE PROPRIETARY DATA AND EXCLUSIVE PROPERTY OF RSG PRODUCTS INC. AND IS DELIVERED ON THE EXPRESS CONDITION THAT NEITHER THIS DOCUMENT NOR THE INFORMATION CONTAINED HEREIN SHALL BE DISCLOSED TO OTHERS, REPRODUCED IN WHOLE OR IN PART, OR USED FOR THE MANUFACTURE OR FABRICATION OF PARTS FOR ANYONE OTHER THAN RSG PRODUCTS INC. WITHOUT WRITTEN CONSENT AND AUTHORIZATION, AND THAT NO RIGHT IS GRANTED TO DISCLOSE OR SO USE ANY INFORMATION CONTAINED IN SAID DOCUMENT. THIS RESTRICTION DOES NOT LIMIT THE RIGHT TO USE INFORMATION OBTAINED FROM ANOTHER SOURCE.</p>	<p>NEXT ASSY.</p>	<p>TOLERANCES EXCEPT AS SHOWN</p> <p>.X: ±.1 .XX: ±.03 .XXX: ±.010 X.X": ±.5" BREAK ALL SHARP EDGES .01 ALL DIMENSIONS IN INCHES UNLESS OTHERWISE STATED</p>			
	<p>APPROVED BY:</p>	<p>DATE:</p>		<p>TITLE: CONDENSER INSTALL</p>	
<p>DRAWN BY: BRP</p>		<p>DATE: 05/25/95</p>	<p>REV.: I</p>	<p>SCALE: N/A</p>	<p>SHEET: 1 OF 4</p>
<p>APPLICATION: AS350</p>		<p>DWG. NO.: 7-2-AS350</p>			

REVISION RECORD

REV	DATE	DESCRIPTION OF CHANGE	APPVD. BY	REV. BY
A	03/27/91	ADDED CP102 AND CP103, INTEGRATED FLIGHT WAS CONSOLIDATED AIRE, TITLE BLOCK WAS CAS, IS IFS.		
B	08/16/00	REVISED DRAWING NUMBER, WAS 5-AS 350; SHEET NUMBER WAS 1 OF 3, ADDED NOTE.		
C	04/12/02	COMPUTERIZED, REVISED TITLE BLOCK.		
D	01/03/07	CORRECTED DRAWING No. REF. WAS 8-AS350, SHEET 1 OF 2. IS 8-11-AS350 SHEET 1 OF 2.		
E	06/30/08	ADDED NOTE 5, REVISED TITLE BLOCK. ADDED TRIM ANNOTATION TO COND. ELBOW ASSY. ADDED INTERCHANGEABLE BLOWERS.		JTYE
F	03/04/10	DELETED BLOWER P/N: IFSS 050084-7 WITH BLOWER P/N: IFSS 050084-7-2.		JM
G	04/08/10	DELETED BLOWER P/N: IFSS 050084-7-1 WITH BLOWER P/N: IFSS 050084-7-3.		JM
H	9/1/14	CHANGED TITLE BLOCK AND REVISION BLOCK. CORRECTED HARDWARE CALLOUT & ADDED SHEET 3 WITH MOUNTING CONFIG. PER ECO # 0289 & 0536		AJC
I	01/19/22	ADDED FLAG NOTE 6 FOR CONFIG. -031 A/C KIT. MODIFIED DIMENSION & NOTES FOR PARTS & HARDWARE. REFLECT FLAG NOTE TO VIEW. FOR SHEET 3 OF 4: MODIFIED OPTIONAL LOCATION HARDWARE CALLOUT. ADDED VIEW OF ALTERNATE LOCATION FOR ELECTRICAL BOX INSTALL IF USING EXISTING OEM CHANNEL. ADDED SHEET 4 OF 4 TO SHOW RELOCATION OF EXISTING DATA TAG FOR AIRBUS INSTALLATION. ADDED VIEW AND NOTES. PER ECO'S 0823, 0956, 0985 AND 1019.		SGB

INTERCHANGEABLE 7" BLOWERS

050084-1
050084-4
050084-6
050084-7
610000 BRUSHLESS
620000 BRUSHLESS
630000
640000
IFSS 050084-1
IFSS 050084-4
IFSS 050084-6
IFSS 050084-6-1
IFSS 050084-7 BRUSHLESS
IFSS 050084-7-1 BRUSHLESS
IFSS 050084-7-2 BRUSHLESS
IFSS 050084-7-3 BRUSHLESS

NOTE:
 INTERCHANGABILITY BETWEEN MS20470AD RIVETS AND CR3243 RIVETS ALLOWABLE. DIAMETER AND LENGTH MAY BE DETERMINED BY INSTALLER.

SINGLE CONDENSER BLOWER
 ENVIRO SYSTEMS INC
 ALT BLOWER: PN 050084-6
 ALT BLOWER: PN 050084-7
 AIR MOVERS, LLC

NOTE A:
 USE CAUTION TO AVOID DAMAGE TO EXISTING WIRE BUNDLE WHEN INSTALLING SHELF

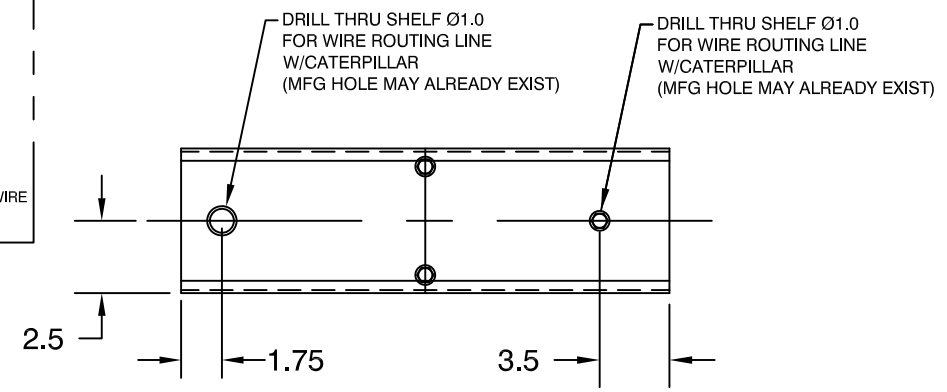

VIEW C-C
 LOOKING UP

FORWARD →

OUTBOARD ↓

FORWARD ↑

← INBOARD

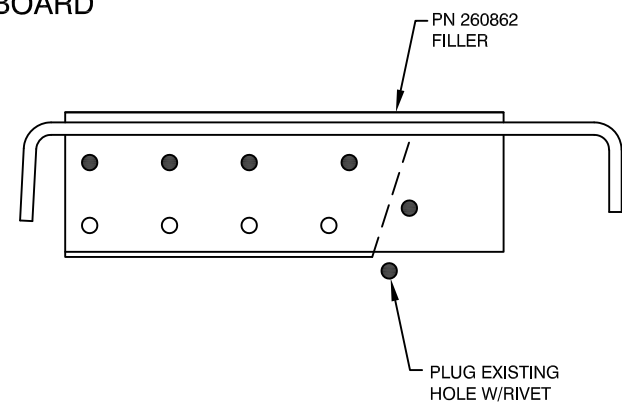

VIEW D-D
 LOOKING DOWN

- CR3243-4-3 RIVET DRILL THRU NEW PART FROM ABOVE USE #27 DRILL
- ⊗ CR3243-4-3 RIVET BACK DRILL #27 HOLE THRU EXISTING HOLE INTO NEW PART
- CR3243-4-4 BACK DRILL #27 THRU EXISTING HOLE

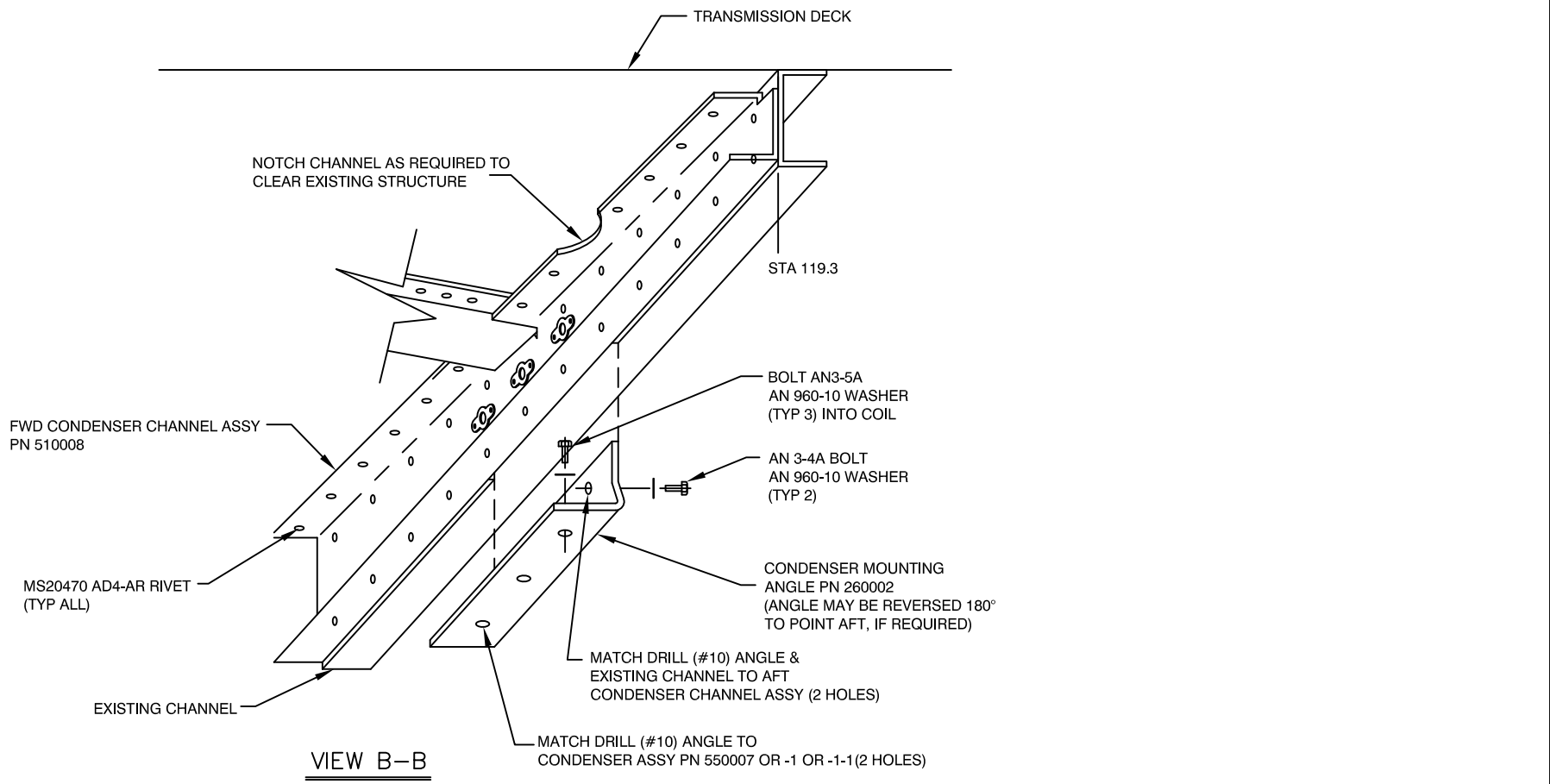

VIEW B-B

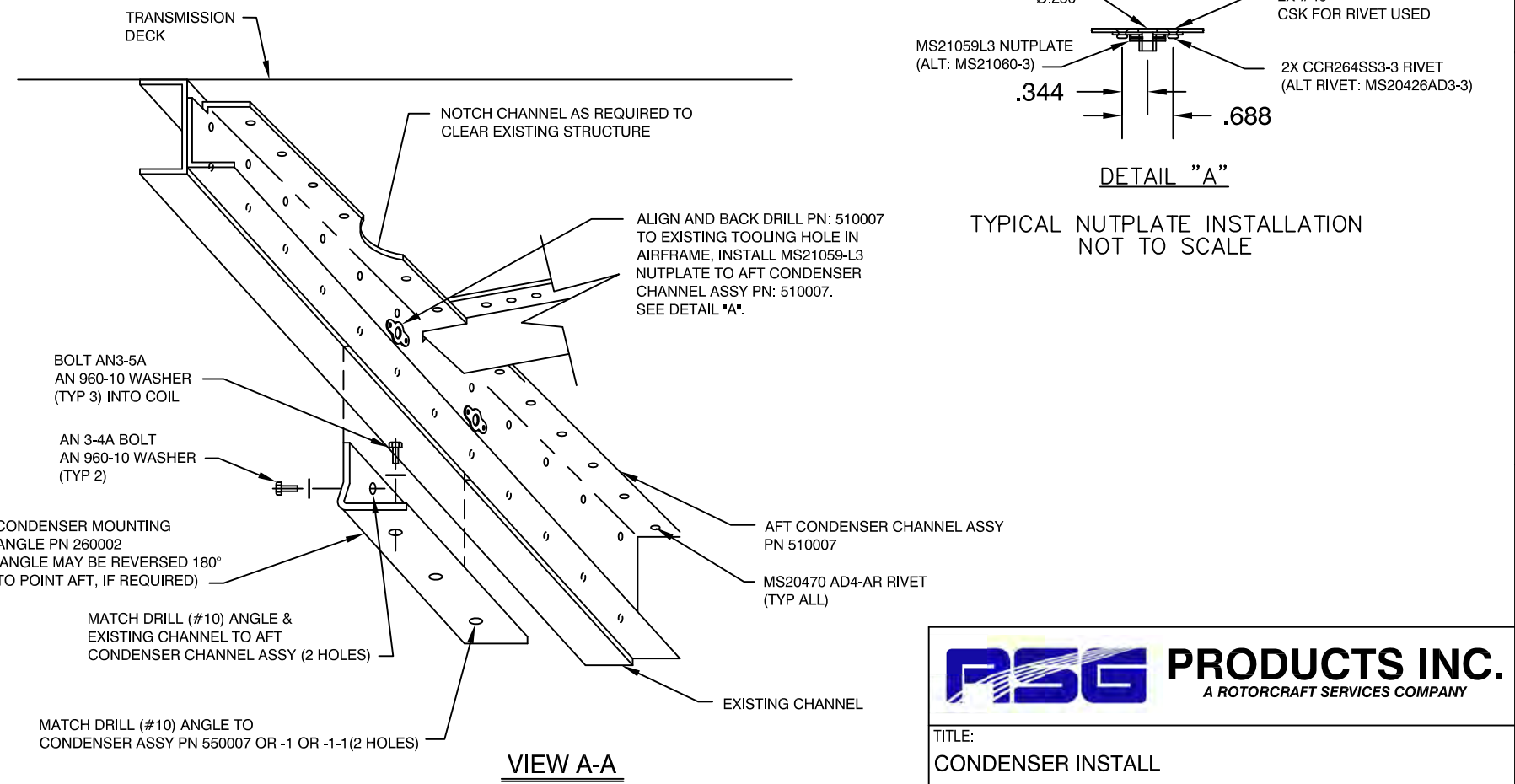

VIEW A-A

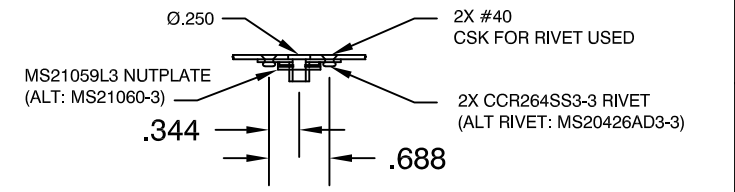

DETAIL "A"

TYPICAL NUTPLATE INSTALLATION
 NOT TO SCALE



TITLE: CONDENSER INSTALL				
DRAWN BY: BRP	DATE: 05/25/95	REV.: I	SCALE: N/A	SHEET: 2 OF 4
APPLICATION: AS350			DWG. NO.: 7-2-AS350	

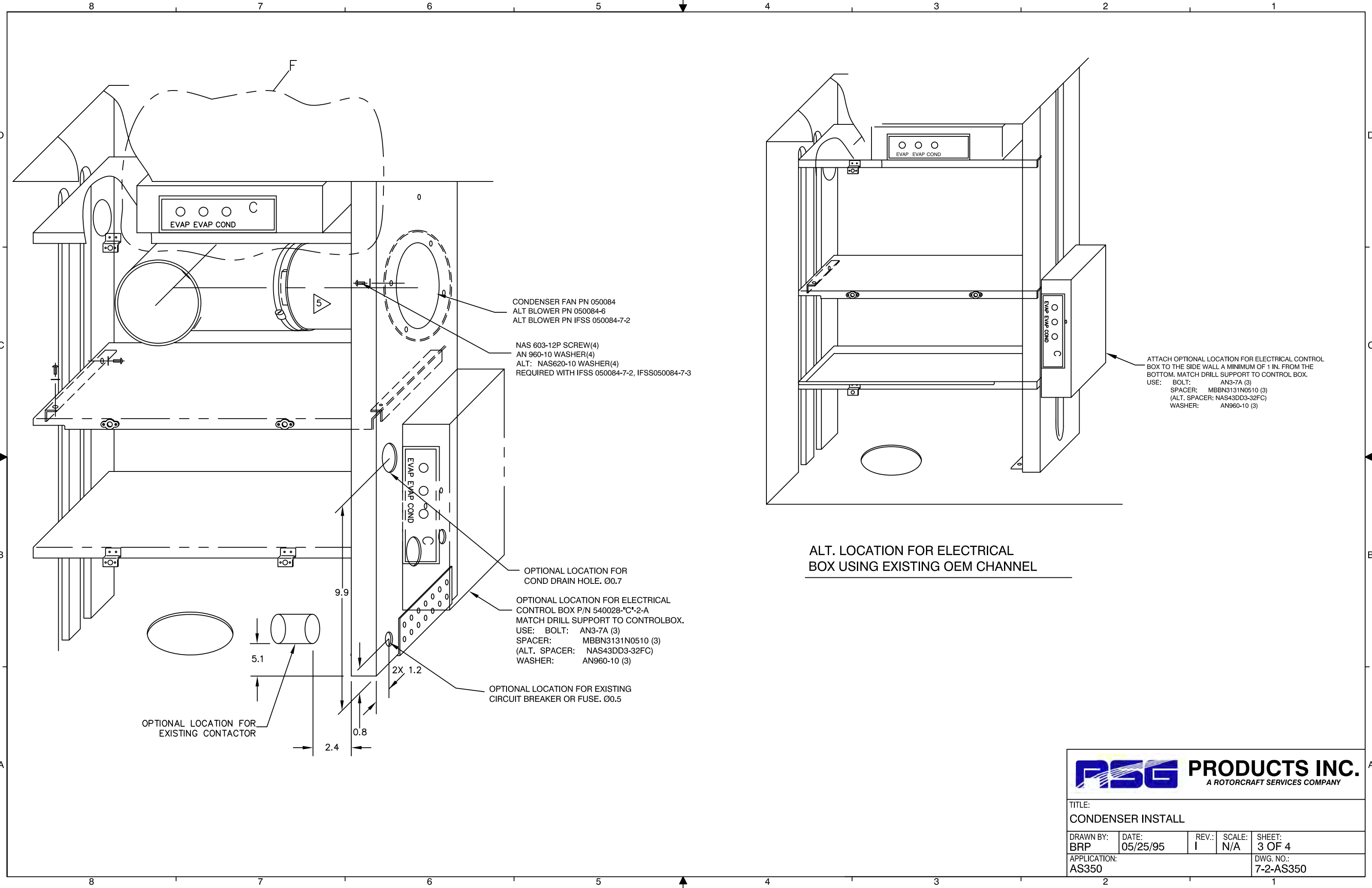

EVAP EVAP COND

CONDENSER FAN PN 050084
 ALT BLOWER PN 050084-6
 ALT BLOWER PN IFSS 050084-7-2

NAS 603-12P SCREW(4)
 AN 960-10 WASHER(4)
 ALT: NAS620-10 WASHER(4)
 REQUIRED WITH IFSS 050084-7-2, IFSS050084-7-3

OPTIONAL LOCATION FOR COND DRAIN HOLE. Ø0.7

OPTIONAL LOCATION FOR ELECTRICAL CONTROL BOX P/N 540028-"C"-2-A
 MATCH DRILL SUPPORT TO CONTROLBOX.
 USE: BOLT: AN3-7A (3)
 SPACER: MBBN3131N0510 (3)
 (ALT. SPACER: NAS43DD3-32FC)
 WASHER: AN960-10 (3)

OPTIONAL LOCATION FOR EXISTING CIRCUIT BREAKER OR FUSE. Ø0.5

OPTIONAL LOCATION FOR EXISTING CONTACTOR

EVAP EVAP COND

EVAP EVAP COND

ATTACH OPTIONAL LOCATION FOR ELECTRICAL CONTROL BOX TO THE SIDE WALL A MINIMUM OF 1 IN. FROM THE BOTTOM. MATCH DRILL SUPPORT TO CONTROL BOX.
 USE: BOLT: AN3-7A (3)
 SPACER: MBBN3131N0510 (3)
 (ALT. SPACER: NAS43DD3-32FC)
 WASHER: AN960-10 (3)

ALT. LOCATION FOR ELECTRICAL BOX USING EXISTING OEM CHANNEL



TITLE: CONDENSER INSTALL				
DRAWN BY: BRP	DATE: 05/25/95	REV.: I	SCALE: N/A	SHEET: 3 OF 4
APPLICATION: AS350			DWG. NO.: 7-2-AS350	

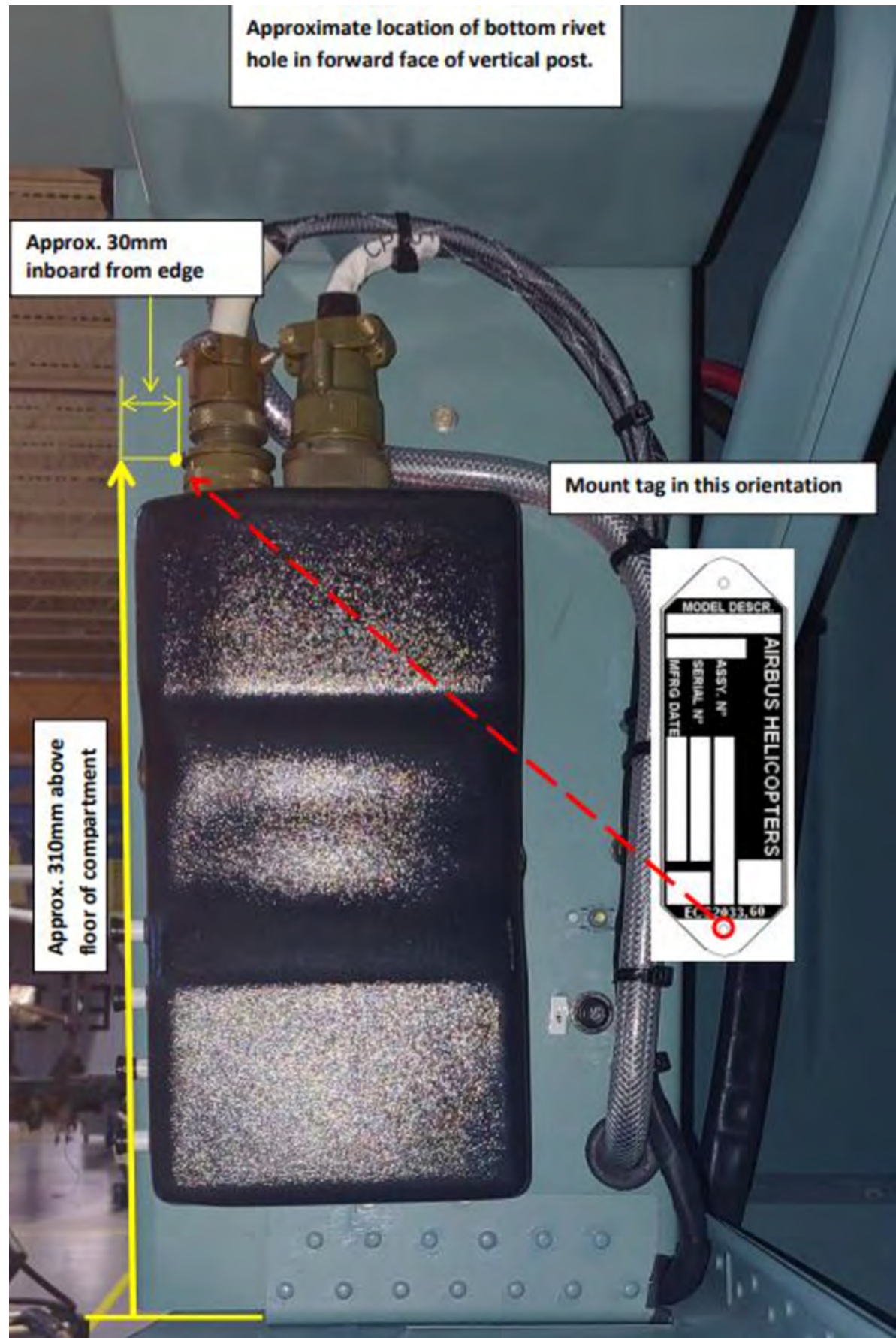

REMOVE DATA TAG ECS 2033.60 FROM TC VERTICAL POST IN RH BAGGAGE COMPARTMENT. INSTALL TAG ON FORWARD FACE OF RSG P/N 260148-3. MAINTAIN ORIGINAL ORIENTATION WHEN MOUNTING. TAG TO BE MOUNTED USING TWO (2) MS20470AD4-5 RIVETS.



TITLE: CONDENSER INSTALL				
DRAWN BY: BRP	DATE: 05/25/95	REV.: I	SCALE: N/A	SHEET: 4 OF 4
APPLICATION: AS350			DWG. NO.: 7-2-AS350	

Step 10

Installation of Hoses

RSG Products Inc.
 INSTALLATION OF HOSES – AS350 Air Conditioning

Installation of hoses

STEP	PROCEDURE	MECH	INSP
10.1	Review Install Drawings 3-5-AS350 and 3-15-AS350.		
10.2	<u>WARNING: Before connecting hoses, be sure all fittings have R134 approved “O” Rings installed.</u>		
10.3	Route evaporator return line hose assembly #10 suction hose (tee fitting above deck), P/N 570087-O-A from the upper transmission deck down through the right side baggage compartment, through the existing opening in the baggage compartment floor, under the floor forward to the forward evaporator. The short length of hose connects to the Aft evaporator return fitting above the transmission deck. The longer length above the transmission deck is routed against the cabin back wall to the compressor suction fitting located on the left side of the transmission.		
10.4	Route the evaporator expansion valve supply line high pressure hose assembly #6, P/N 570072-O-A from the baggage department down through the existing opening in the baggage compartment floor, under the floor forward to the forward evaporator. The tee fitting connects to the “out” or supply fitting on the dryer bottle. The short length to the evaporator.		
10.5	Clamp the coil on the end of the expansion valve to the return hose fitting (#10 large line) with a 1-inch band clamp. Assure the fitting is clean where the coil is clamped. Insulate the coil completely with cork tape, P/N 070078-0, PER DRAWING NO. 3-5-A350		
10.6	Route THE CONDENSER SUPPLY LINE HOSE ASSEMBLY #8, P/N 570070-O-A from the compressor discharge fitting against the cabin back wall to the right side of the transmission deck. Route down the same opening in the transmission deck as the return hose was routed. Connect to cone condenser. Route hose assembly #6, P/N 570067-O-A, along beside #8 line as shown in Drawing No. 3-5-AS350.		

Installation of Hoses

STEP	PROCEDURE	MECH	INSP
10.7	Install drier mount bracket, P/N 260123-2 per Drawing No. 3-5-AS350 and drier bottle, P/N 090016-5.		
10.8	Do not connect drier bottle up until all lines are connected and you are ready to vacuum down system.		
10.9	Connect high and low pressure switches. Be sure to connect the correct wire to each switch. Low pressure switch P/N 050107, High pressure switch, P/N 90004.		

REVISION RECORD				
REV	DATE	DESCRIPTION OF CHANGE	APPVD. BY	REV. BY
C	09/1/14	CHANGED TITLE BLOCK AND REVISION BLOCK. INCORPORATED ECO # 0279 AND 0509.		AJC
D	08/04/23	INCORPORATED ECO'S 1091 AND 1184.		SGB

SEE ECO 1297
SEE ECO 1299

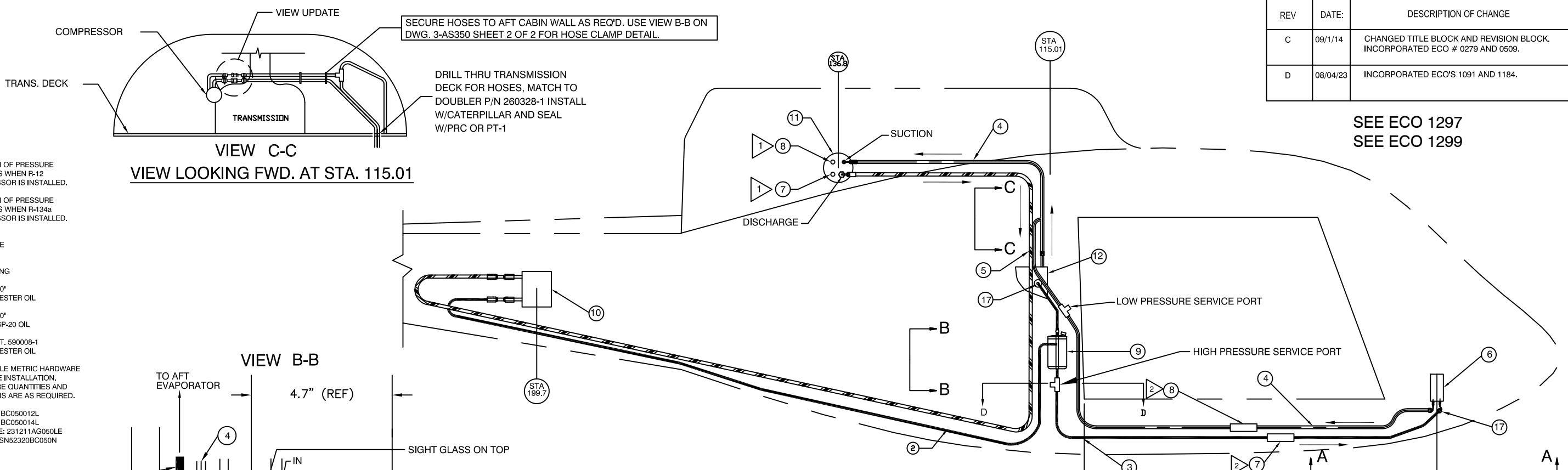

- NOTES:
- 1 LOCATION OF PRESSURE SWITCHES WHEN R-12 COMPRESSOR IS INSTALLED.
 - 2 LOCATION OF PRESSURE SWITCHES WHEN R-134a COMPRESSOR IS INSTALLED.
 - 3 590001 R-12 FLARE
 - 4 590001-10" R-12 10" RING
 - 5 590001-1-0" R-134a W/ESTER OIL
 - 6 590001-2-0" R134a W/SP-20 OIL
 - 7 590008 ALT. 590008-1 R-134a W/ESTER OIL
 - 8 4. ALLOWABLE METRIC HARDWARE FOR HOSE INSTALLATION. HARDWARE QUANTITIES AND LOCATIONS ARE AS REQUIRED.
 - 9 VIS: 22201BC050012L
 - 10 VIS: 22201BC050014L
 - 11 RONDELLE: 231211AG050LE
 - 12 ECROU: ASN52320BC050N

VIEW C-C
VIEW LOOKING FWD. AT STA. 115.01

VIEW B-B

VIEW D-D
VIEW LOOKING DOWN

VIEW A-A
VIEW LOOKING UP

QTY	ITEM	PART NUMBER	DESCRIPTION
12	22	MS20470AD4	RIVET
3	21	090094	#10 O-RING
3	20	090093	#8 O-RING
5	19	090092	#6 O-RING
1	18	060036	3 INCH BAND CLAMP
2	17	090002-O	EXPANSION VALVE
1	16	260123-2	RECEIVER DRIER MOUNT
2	15	MS21044-N3	NUT
4	14	AN960-10	WASHER
2	13	AN3-5A	BOLT
1	12	560010-O-5	AFT EVAPORATOR
1	11	590008	COMPRESSOR 24 VDC R-134a O-RING (590008-1)
1	10	5500022	CONDENSER
1	9	090016-5	RECEIVER DRIER BOTTLE
1	8	050107	LOW PRESSURE SWITCH
1	7	090004	HIGH PRESSURE SWITCH
1	6	560025-O	FORWARD EVAPORATOR
1	5	570070-O-A	HOSE ASSY COMPRESSOR TO CONDENSER
1	4	570087-O-A	HOSE ASSY FWD EVAPORATOR TO AFT EVAPORATOR
1	3	570072-O-A	HOSE ASSY. AFT EVAP TO FWD. EVAP TO REC./DRIER
1	2	570067-O-A	HOSE ASSY. COND. TO REC./DRIER

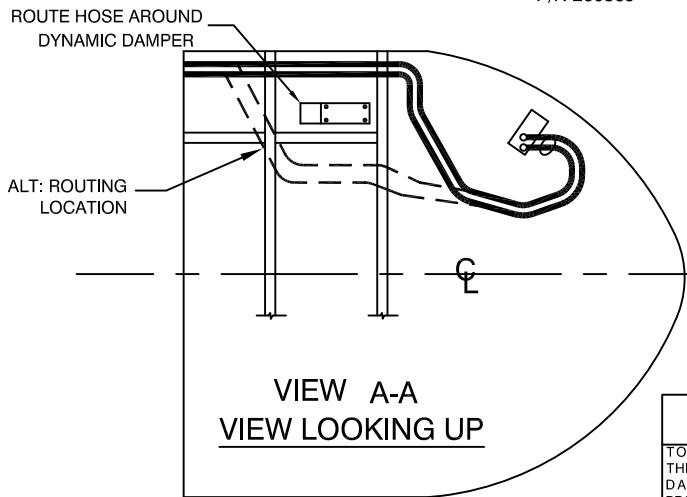
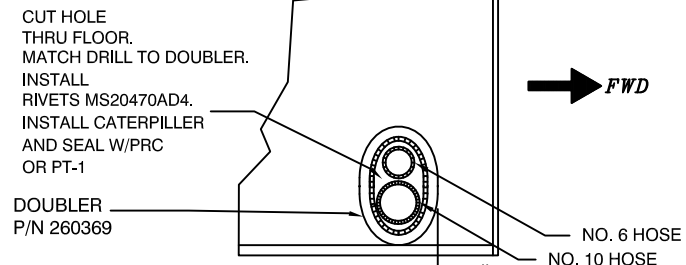

- NOTES:
- ALTERNATE HOSE:
1991-ON NEOPRE BARRIER TYPE
- #6 P/N 090078
 - #8 P/N 090079
 - #10 P/N 090080
- 1995-ON NEOPRENE REDUCED BARRIER TYPE
- #6 P/N 090089
 - #8 P/N 090090
 - #10 P/N 090091
- FERRULES FOR ABOVE
- #6 P/N 090081
 - #8 P/N 090082
 - #10 P/N 090083

MUST USE ATCO REDUCED BARRIER TYPE FITTINGS & ATCO CRIMPER P/N 3700 OR MASTERCOOL P/N 71500

PROPRIETARY NOTICE

TO ALL PERSONS RECEIVING THIS DOCUMENT THIS DOCUMENT AND INFORMATION OR TECHNICAL DATA AND DESIGNS CONTAINED HEREIN ARE PROPRIETARY DATA AND EXCLUSIVE PROPERTY OF RSG PRODUCTS INC. AND IS DELIVERED ON THE EXPRESS CONDITION THAT NEITHER THIS DOCUMENT NOR THE INFORMATION CONTAINED HEREIN SHALL BE DISCLOSED TO OTHERS, REPRODUCED IN WHOLE OR IN PART, OR USED FOR THE MANUFACTURE OR FABRICATION OF PARTS FOR ANYONE OTHER THAN RSG PRODUCTS INC. WITHOUT WRITTEN CONSENT AND AUTHORIZATION, AND THAT NO RIGHT IS GRANTED TO DISCLOSE OR SO USE ANY INFORMATION CONTAINED IN SAD DOCUMENT. THIS RESTRICTION DOES NOT LIMIT THE RIGHT TO USE INFORMATION OBTAINED FROM ANOTHER SOURCE.

APPROVED BY:

NEXT ASSY.

TOLERANCES EXCEPT AS SHOWN

.X: ±.1
.XX: ±.03
.XXX: ±.010
X.X": ±.5"
BREAK ALL SHARP EDGES .01
ALL DIMENSIONS IN INCHES UNLESS OTHERWISE STATED

DATE:

RSG PRODUCTS INC.
A ROTORCRAFT SERVICES GROUP COMPANY

TITLE:
PLUMBING DIAGRAM

DRAWN BY: N.DEAN DATE: 11/01/99 REV.: D SCALE: N/A SHEET: 1 OF 1

APPLICATION: AS350 DWG. NO.: 3-5-AS350



ENGINEERING CHANGE ORDER

ECO No. 1297 SHT 1 OF 1

DWG No. 3-5-AS350 REV D

DWG No. REV

DWG No. REV

REF. STC No. SH3509SW

CHANGE CLASS:
 RECORD CHG. PARTS NOT AFFECTED NON-INTERCHANGEABLE PARTS
 INTERCHANGEABLE PARTS OTHER _____

EXISTING/IN-WORK STOCK DISPOSITION:
 RECORD CHG. PARTS NOT AFFECTED RE-WORK EXISTING STOCK
 SCRAP EXISTING STOCK OTHER BREAK IN AT NEXT BUILD

EFFECTIVITY:
 ALL UNITS THIS CUSTOMER LIMITED UNITS SPECIFIED
 ALL UNITS MFG'D AFTER THIS DATE OTHER ALL UNITS

DESCRIPTION OF CHANGE: CORRECT TYPO FOR NOTE IN ZN D6.

WAS:

SECURE HOSES TO AFT CABIN WALL AS REQ'D. USE VIEW B-B ON DWG. 3-AS350 SHEET 2 OF 2 FOR HOSE CLAMP DETAIL.

IS:

SECURE HOSES TO AFT CABIN WALL AS REQ'D. USE VIEW B-B ON DWG. 3-15-AS350 SHEET 1 OF 1 FOR HOSE CLAMP DETAIL.

REMARKS: MINOR CHANGE.
CORRECT TYPO.

ENGINEERING REVIEW BOARD		
SIGNATURE	STAMP	DATE
	MRB04	3/4/2024
	QA22 P016	3/5/2024 3/5/2024
INCORPORATION STATUS		
<input type="checkbox"/> IMMEDIATE <input checked="" type="checkbox"/> OUTSTANDING		



ENGINEERING CHANGE ORDER

ECO No.	1299	SHT 1 OF 2
DWG No.	3-5-AS350	REV D
DWG No.		REV
DWG No.		REV

REF. STC No. **SH3509SW**

EFFECTIVITY:
 ALL UNITS THIS CUSTOMER LIMITED UNITS SPECIFIED
 ALL UNITS MFG'D AFTER THIS DATE OTHER ALL UNITS

CHANGE CLASS:
 RECORD CHG. PARTS NOT AFFECTED NON-INTERCHANGEABLE PARTS
 INTERCHANGEABLE PARTS OTHER _____

EXISTING/IN-WORK STOCK DISPOSITION:
 RECORD CHG. PARTS NOT AFFECTED RE-WORK EXISTING STOCK
 SCRAP EXISTING STOCK OTHER BREAK IN AT NEXT BUILD

DESCRIPTION OF CHANGE: ADD INSTALLATION NOTE TO VIEW C-C FOR P/N: 04-130-21-107-01 X2. ALSO ADD DETAIL E FOR INSTALLATION OF P/N: 04-130-21-107-01 X2. ONLY SHOWING WHAT CHANGED FOR CLARITY.

WAS:

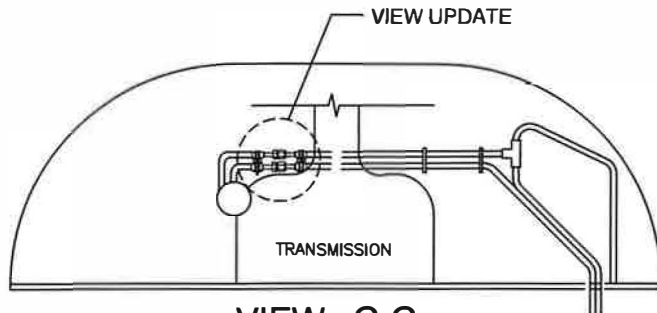

VIEW C-C
VIEW LOOKING FWD. AT STA. 115.01

REMARKS: MINOR CHANGE.
 ADD NOTE AND DETAIL FOR VIEW C-C.

ENGINEERING REVIEW BOARD		
SIGNATURE	STAMP	DATE
<i>[Signature]</i>	MRB04	4/3/2024
<i>[Signature]</i>	QA22	4/3/2024
<i>[Signature]</i>	P016	4/3/2024

INCORPORATION STATUS
 IMMEDIATE OUTSTANDING



ENGINEERING
CHANGE
ORDER

ECO No. 1299	SHT 2 OF 2
DWG No. 3-5-AS350	REV D
DWG No.	REV
DWG No.	REV
REF. STC No. SH3509SW	

IS:

ATTACH P/N 04-130-21-107-01 BRACKET
TO WALL & SECURE HOSES AS REQ'D.
LOCATE FOR BEST FIT. SEE VIEW B-B
ON DWG. 3-15-AS350 FOR HOSE CLAMP
DETAIL. USE HOSE CLAMP
MS21919WDG11 FOR #8 HOSE AND
MS21919WDG12 FOR #10 HOSE

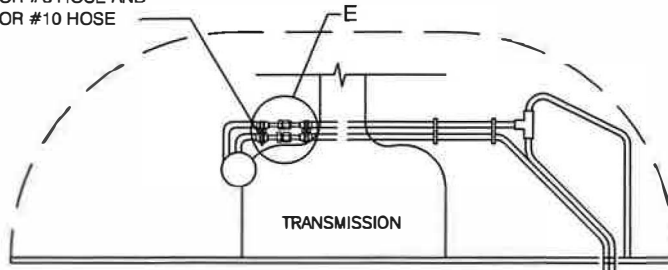

VIEW C-C
VIEW LOOKING FWD. AT STA. 115.01

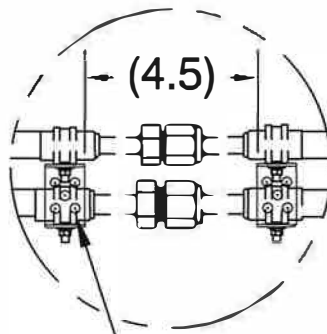

5X MATCH DRILL Ø.128 WALL TO P/N:
04-130-21-107-01 BRACKET. INSTALL
MS20470AD4-0 RIVETS.

DETAIL E

REVISION RECORD				
REV	DATE	DESCRIPTION OF CHANGE	APPVD. BY	REV. BY
A	05/06/02	CONVERTED TO AUTOCAD.		
B	09/09/09	REVISED TITLE BLOCK.		
C	9/1/14	CHANGED TITLE BLOCK AND REVISION BLOCK.		AJC

NOTE:
 USE EXISTING LIGHTENING HOLES ONLY FOR ALL ROUTING (PREFERRED).
 INSTALL PER VIEW B-B OR ALTERNATE VIEW B-B OR VIEW C-C
 EXTREMELY IMPORTANT
 FAILURE TO SECURE EXPANSION VALVE SENSING BULB, TIGHTLY, TO THE RETURN LINE HOSE FITTING (#10) WITH A STAINLESS STEEL CLAMP (AND INSULATE SENSING BULB & LINE) WILL DRAMATICALLY DECREASE THE PERFORMANCE OF THE AFT EVAPORATOR (NOT FORWARD).

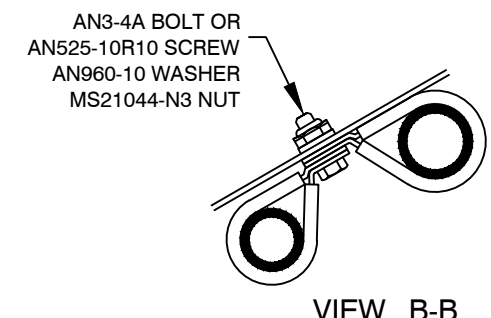
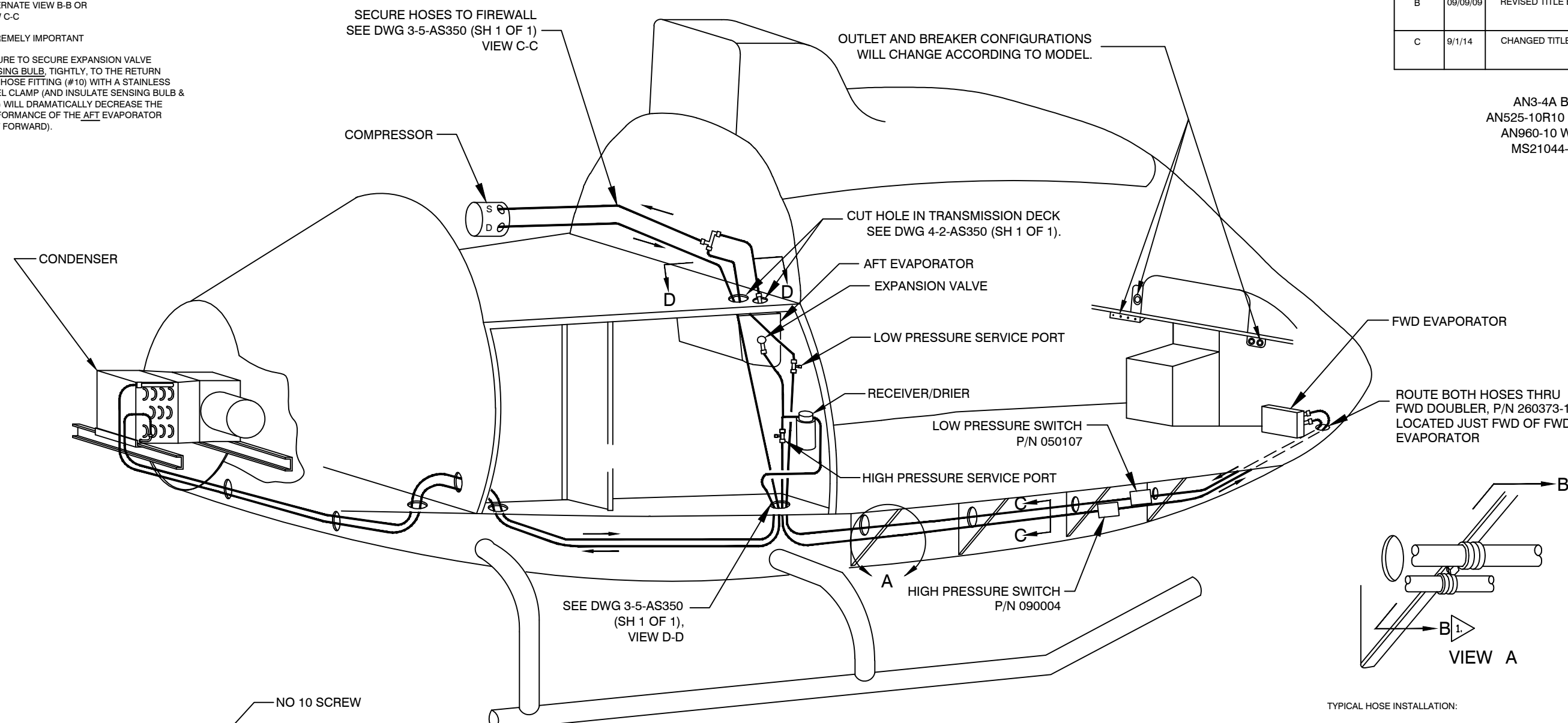

1. ALTERNATE: P/N LHMS-S10D MOUNT USE #10 SCREW OR AN3 BOLT WITH TIE WRAP & ZZCR4HM BLOCK IF DESIRED (SEE VIEW B-B "ALTERNATE")

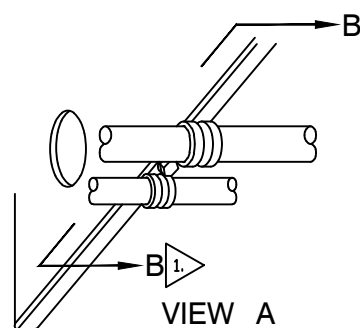

TYPICAL HOSE INSTALLATION:
 FOR #6 HOSE ATTACH WITH ADEL CLAMP MS21919DG10 & HARDWARE AS SHOWN
 FOR #8 HOSE ATTACH WITH ADEL CLAMP MS21919DG11 & HARDWARE AS SHOWN
 FOR #10 HOSE ATTACH WITH ADEL CLAMP MS21919DG12 & HARDWARE AS SHOWN
 NOTE: INWARD PLACEMENT OF CLAMPS TO FACILITATE INSTALLATION USING ONLY ONE SCREW, WASHER, & NUT SET-UP.

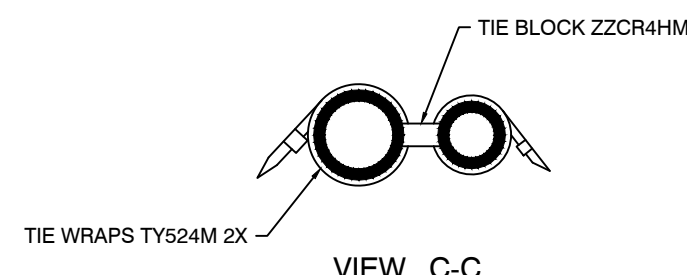
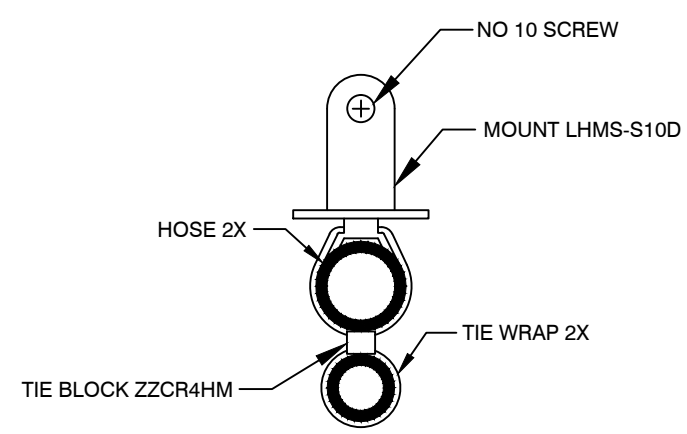

PROPRIETARY NOTICE TO ALL PERSONS RECEIVING THIS DOCUMENT THIS DOCUMENT AND INFORMATION OR TECHNICAL DATA AND DESIGNS CONTAINED HEREIN ARE PROPRIETARY DATA AND EXCLUSIVE PROPERTY OF RSG PRODUCTS INC. AND IS DELIVERED ON THE EXPRESS CONDITION THAT NEITHER THIS DOCUMENT NOR THE INFORMATION CONTAINED HEREIN SHALL BE DISCLOSED TO OTHERS, REPRODUCED IN WHOLE OR IN PART, OR USED FOR THE MANUFACTURE OR FABRICATION OF PARTS FOR ANYONE OTHER THAN RSG PRODUCTS INC. WITHOUT WRITTEN CONSENT AND AUTHORIZATION, AND THAT NO RIGHT IS GRANTED TO DISCLOSE OR SO USE ANY INFORMATION CONTAINED IN SAD DOCUMENT. THIS RESTRICTION DOES NOT LIMIT THE RIGHT TO USE INFORMATION OBTAINED FROM ANOTHER SOURCE.	NEXT ASSY.	TOLERANCES EXCEPT AS SHOWN
	APPROVED BY:	.X: ±.1 .XX: ±.03 .XXX: ±.010 X.X": ±.5° BREAK ALL SHARP EDGES .01 ALL DIMENSIONS IN INCHES UNLESS OTHERWISE STATED DATE:

TITLE: PLUMBING ROUTING	
DRAWN BY: MAH	DATE: 11/01/99
REV.: C	SCALE: N/A
SHEET: 1 OF 1	DWG. NO.: 3-15-AS350

Step 11

Paperwork



DATE:
08/04/2023

DOC No.:
IFSE-0007

REV:
F-1

PAGE:
97 of 99

TITLE:
Air Conditioning System Installation Instructions For Continued
Airworthiness for Airbus Helicopters AS-350 B, C, D, D1, B1, B2, B3, BA &
EC-130 B4

PERTAINS TO KIT #350-00-031
Weight (#) X Arm (") = Moment ("#)

ITEM	WEIGHT (#)	ARM (")	MOMENT ("#)
Forward Evaporator Assembly	13.50	19.00	256.50
Forward Air Outlets	.50	31.32	15.66
Aft Evaporator and Return Air	11.50	120.00	1380.00
Aft Evaporator Blower	5.00	120.85	604.25
Condenser Assy. & Mount w/ Dual condenser blowers and closeout panel	40.00	201.80	8072.00
Compressor and Mount	17.00	147.80	2512.60
Electrical Relay Panes	4.0	153.70	614.80
Refrigerant, Hoses and Fittings	7.50	76.90	576.75
Sub Total: (Air Conditioner)	99.00		14032.56



United States of America
Department of Transportation
Federal Aviation Administration

Supplemental Type Certificate

Number: SH3509SW

This certificate issued to: RSG Products Inc.
440 West Lane Suite 100
Saginaw TX, 76131

Certifies that the change in the type design for the following product with the limitations and conditions therefore as specified hereon meets the airworthiness requirements of 27 of Federal Aviation Regulations

Original Product *Make:* Airbus Helicopters
Type Certificate Number: H9EU *Model:* AS350 B, B1, B2, B3, BA, C, D, D1;
Description of Type Design Change: EC130B4

Installation of a Single and Dual Condenser Blower Air Conditioning System in accordance with Integrated Flight Systems (IFS) Master Drawing List (MDL), Document No. DL-9 (Vapor Cycle Air Conditioning System with Belt Driven Compressor Utilizing Refrigerant R134a), Rev. T, dated 09/01/2014, or later FAA approved revision.

(See continuation sheet 3 of 3)

Limitations and Conditions:

The installer must determine whether this design change is compatible with previously approved modifications. If the holder agrees to permit another person to use this certificate to alter a product, the holder must give the other person written evidence of that permission.

This certificate and the supporting data which is the basis for approval shall remain in effect until surrendered, suspended, revoked, or a termination date is otherwise established by the Administrator of the Federal Aviation Administration.

Date of Application: September 10, 1984 *Date Reissued:* April 30, 1991; August 22, 2001; October 23, 2008; August 26, 2011; November 29, 2021
Date of Issuance: September 20, 1985 *Date Amended:* February 11, 1999; February 9, 2009; February 23, 2009; November 5, 2010; September 14, 2015

By Direction of the Administrator

SARAH F COX Digitally signed by SARAH F COX
Date: 2021.12.06 08:09:25 -06'00'

Signature: Jim Grigg
Title: Manager, Fort Worth ACO Branch
Compliance & Airworthiness Division
Aircraft Certification Service

Any alteration of this certificate is punishable by a fine of not exceeding \$1,000, or imprisonment not exceeding 3 years, or both. This certificate may be transferred or made available to third persons by licensing agreements in accordance with 14 CFR 21.47. Possession of this Supplemental Type Certificate (STC) document by persons other than the STC holder does not constitute rights to the design data nor to alter an aircraft, aircraft engine, or propeller. The STC's supporting documentation (drawings, instructions, specifications, flight manual supplements, etc.) is the property of the STC holder. An STC holder who allows a person to use the STC to alter an aircraft, aircraft engine, or propeller must provide that person with written permission acceptable to the FAA. (Ref. 14 CFR 21.120).



United States of America
Department of Transportation
Federal Aviation Administration
Supplemental Type Certificate

Number: SH3509SW

INSTRUCTIONS: The transfer endorsement below may be used to notify the appropriate FAA Aircraft Certification Office of the transfer of this Supplemental Type Certificate. The FAA will reissue the certificate in the name of the transferee and forward it to him.

Transfer Endorsement

Transfer the ownership of Supplemental Type Certificate Number: _____

To (Name and address of transferee):

From (Name and address of grantor):

Extent of Authority (if licensing agreement):

Date of transfer:

Signature of grantor: _____

Any alteration of this certificate is punishable by a fine of not exceeding \$1,000, or imprisonment not exceeding 3 years, or both. This certificate may be transferred or made available to third persons by licensing agreements in accordance with 14 CFR 21.47. Possession of this Supplemental Type Certificate (STC) document by persons other than the STC holder does not constitute rights to the design data nor to alter an aircraft, aircraft engine, or propeller. The STC's supporting documentation (drawings, instructions, specifications, flight manual supplements, etc.) is the property of the STC holder. An STC holder who allows a person to use the STC to alter an aircraft, aircraft engine, or propeller must provide that person with written permission acceptable to the FAA. (Ref. 14 CFR 21.120).



United States of America
Department of Transportation
Federal Aviation Administration

Supplemental Type Certificate

(Continuation Sheet)

Number: SH3509SW

Date of Issuance: September 20, 1985

Date Reissued: November 29, 2021

Description of Type Design Change

For Single Condenser Configurations the following FAA Approved Flight Manual Supplements (FMSs) and revisions, or later FAA approved revisions, are required accordingly:

AS350B, C, D, D1: FMS 19-350-21-002-011, Rev. D, dated 11/17/2014.
AS350B1: FMS 19-350-21-004-011, Rev. C, dated 11/17/2014.
AS350B2: FMS 19-350-21-006-011, Rev. B, dated 11/17/2014.
AS350B3: FMS 19-350-21-008-011, Rev. B, dated 11/17/2014.
AS350BA: FMS 19-350-21-010-011, Rev. B, dated 11/17/2014.
EC130B4: FMS dated 2/6/04.

For Dual Condenser Configurations the following FAA approved FMSs and revisions, or later FAA approved revisions, are required accordingly:

AS350B, C, D, D1: FMS 19-350-21-001-031, Rev. D, dated 11/17/2014.
AS350B1: FMS 19-350-21-003-031, Rev. C, dated 11/17/2014.
AS350B2: FMS 19-350-21-005-031, Rev. B, dated 11/17/2014.
AS350B3: FMS 19-350-21-007-031, Rev. B, dated 11/17/2014.
AS350BA: FMS 19-350-21-009-031, Rev. B, dated 08/18/2015.

Instructions for Continued Airworthiness, IFS Document No. IFSE-0007, Rev. C, dated 8/12/2010, or later revision is required.

-----END-----

Any alteration of this certificate and/or the Type Certificate Data Sheet is punishable by a fine not exceeding \$1,000, or imprisonment not exceeding 3 years, or both. This certificate may be transferred or made available to third persons by licensing agreements in accordance with Title 14 of the Code of Federal Regulations, part 21, section 21.47 (14 CFR 21.47). A transfer must be endorsed as provided on the reverse hereof. A Type Certificate holder who allows a person to use the Type Certificate to manufacture a new aircraft, aircraft engine, or propeller must provide that person with a written licensing agreement acceptable to the FAA. (Ref. 14 CFR 21.55).

Foreign Applicability for STC SH3509SW
can be found on the Customer Support
page using the link below:

<https://rotorcraftservices.com/wp-content/uploads/2023/10/SH3509SW-AS350-EC130.pdf>



DRAWING NUMBER	DRAWING TITLE	# OF PAGES	DRAWING DATE	REVISION	DESCRIPTION	AS 350	EC130B4	SIZE	NEW/RVSD
1-0-AS350	AIR CONDITIONING CONFIGURATION CONTROL	2	01/19/22	D	AS 350	X		B	TO REV. D
1-0-EC130	AIR CONDITIONING CONFIGURATION CONTROL	1	09/01/14	B	EC 130 B4		X	B	TO REV. B
1-00-EC130	CONFIGURATION AND ADD OPTIONS	1	09/01/14	B	EC 130 B4		X	B	TO REV. B
1-1-AS350	AIR CONDITIONING OVERVIEW	1	09/01/14	G	CORPORATE VERSION	X		B	TO REV. G
1-2-AS350	AIR CONDITIONING OVERVIEW	1	09/01/14	D	EMS-2 VERSION	X		B	TO REV. D
1-3-AS350	AIR CONDITIONING OVERVIEW	1	01/19/22	F	ECL TOUR-2 VERSION	X		B	TO REV. F
1-4-AS350	AIR CONDITIONING OVERVIEW	1	09/01/14	D	ECL TOUR-1 VERSION	X		B	TO REV. D
1-5-AS350	AIR CONDITIONING OVERVIEW	1	08/04/23	F	AFT MOUNTED CONDENSER	X		B	TO REV. F
1-6-AS350	AIR CONDITIONING OVERVIEW	1	09/01/14	B	LAW ENFORCEMENT	X		B	TO REV. B
1-7-AS350	AIR CONDITIONING OVERVIEW	1	01/19/22	C	ECL TOUR 1	X		B	TO REV. C
1-8-AS350	AIR CONDITIONING OVERVIEW	1	09/01/14	B	EMS 1	X		B	TO REV. B
1-1-EC130	AIR CONDITIONING OVERVIEW	1	09/01/14	B	EC130		X	B	TO REV. B
2-00-AS350	ELECTRICAL ROUTING	1	09/01/14	B	AS350	X		B	TO REV. B
2-1-AS350	ELECTRICAL ROUTING	1	09/01/14	F	SINGLE CONDENSER BLOWER	X		B	TO REV. F
2-2-AS350	ELECTRICAL ROUTING	1	09/01/14	D	EMS-2 VERSION	X		B	TO REV. D
2-3-AS350	ELECTRICAL ROUTING	1	01/19/22	E	SINGLE COND/ECL/TOUR	X		B	TO REV. E
2-4-AS350	ELECTRICAL ROUTING	1	01/19/22	E	DUAL AFT/ECL TOUR	X		B	TO REV. E
2-5-AS350	ELECTRICAL ROUTING	1	09/01/14	D	DUAL COND. BLOWER/AFT MOUNT	X		B	TO REV. C
2-6-AS350	ELECTRICAL ROUTING	1	09/01/14	C	DUAL COND/SIDE MOUNT	X		B	TO REV. C
2-8-AS350	ELECTRICAL ROUTING	1	09/01/14	C	CORP. TOUR 2, EMS AND LAW ENF.	X		B	TO REV. C
2-9-AS350	ELECTRICAL ROUTING	1	09/01/14	B	EMS/ LAW ENFORCEMENT	X		B	TO REV. B
2-10-AS350	ELECTRICAL ROUTING	1	09/01/14	B	EMS-1	X		B	TO REV. B
2-11-AS350	ELECTRICAL DIAGRAM	1	01/19/22	L	ADDED EMI-RFI FILTERS	X		B	TO REV. L
2-13-AS350	ELECTRICAL DIAGRAM	1	01/19/22	I	ADDED EMI-RFI FILTER	X		B	TO REV. I
2-14-AS350	ELECTRICAL DIAGRAM	1	01/19/22	E	AFT MOUNTED/ECL TOUR	X		B	TO REV. E
2-16-AS350	ELECTRICAL DIAGRAM	1	01/19/22	G	DUAL COND. BLOWER/AFT MOUNT	X		B	TO REV. G
2-19-AS350	ELECTRICAL ROUTING	1	01/19/22	D	ECL TOUR 2	X		B	TO REV. D
2-21-AS350	ELECTRICAL DIAGRAM	1	01/19/22	G	SINGLE COND BLOWER	X		B	TO REV. G
2-23-AS350	ELECTRICAL DIAGRAM	1	01/19/22	F	SINGLE COND/ECL TOUR 1	X		B	TO REV. F
2-24-AS350	ELECTRICAL DIAGRAM	1	01/19/22	E	DUAL AFT/ECL TOUR 1	X		B	TO REV. E
2-25-AS350	ELECTRICAL DIAGRAM	1	01/19/22	F	DUAL COND BLOWER	X		B	TO REV. F
2-29-AS350	ELECTRICAL ROUTING	1	01/19/22	C	ECL TOUR 2	X		B	TO REV. C
2-1-EC130	ELECTRICAL ROUTING	1	08/04/23	C	EC130		X	B	TO REV. C
2-3-EC130	ELECTRICAL DIAGRAM	1	09/01/14	B	EC130		X	B	TO REV. B
3-4-AS350	PLUMBING DIAGRAM	1	08/04/23	E	AFT EVAP/SIDE MOUNT	X		B	TO REV. E
3-5-AS350	PLUMBING DIAGRAM	1	08/04/23	D	ALT AFT EVAP/AFT MOUNT	X		B	TO REV. D
3-14-AS350	PLUMBING ROUTING	1	09/01/14	C	AFT EVAP/SIDE MOUNT	X		B	TO REV. C
3-15-AS350	PLUMBING DIAGRAM	1	09/01/14	C	ALT AFT EVAP/AFT MOUNT	X		B	TO REV. C
3-1-EC130	PLUMBING DIAGRAM	1	09/01/14	B	PLUMBING DIAGRAM		X	B	TO REV. B
3-2-EC130	PLUMBING ROUTING	1	09/01/14	B	PLUMBING DIAGRAM		X	B	TO REV. B
4-3-AS350	AFT EVAP INSTALL	2	08/04/23	F	AFT EVAPORATOR	X		B	TO REV. F
4-13-AS350	AFT EVAP INSTALL	1	08/04/23	D	AFT EVAPORATOR INSTALL	X		B	TO REV. D
4-21-AS350	FWD EVAP INSTALL	1	08/04/23	J	FWD EVAPORATOR INSTALL	X		B	TO REV. J
4-1-EC130	AFT EVAP INSTALL	2	08/04/23	D	AFT EVAPORATOR INSTALL		X	B	TO REV. D
4-2-EC130	AFT EVAP INSTALL	1	09/01/14	B	AFT EVAPORATOR INSTALL		X	B	TO REV. B
4-3-EC130	FWD EVAP INSTALL	2	09/01/14	B	FWD EVAPORATOR INSTALL		X	B	TO REV. B
4-4-EC130	FWD DRAIN HOSE INSTALL	1	09/01/14	A	FWD DRAIN HOSE INSTALL		X	B	TO REV. A
5-1-AS350	AIR DISTRIBUTION	1	09/01/14	E	CORPORATE	X		B	TO REV. E
5-2-AS350	AIR DISTRIBUTION	1	09/01/14	E	EMS 2	X		B	TO REV. E
5-4-AS350	AIR DISTRIBUTION	1	01/19/22	F	ECL TOUR VERSION	X		B	TO REV. F
5-5-AS350	AIR DISTRIBUTION	1	09/01/14	D	ECL TOUR 2	X		B	TO REV. D
5-6-AS350	AIR DISTRIBUTION	1	09/01/14	B	EMS-1	X		B	TO REV. B
5-9-AS350	AIR CONDITIONING OVERVIEW	1	09/01/14	E	LAW ENFORCEMENT	X		B	TO REV. E
5-10-AS350	AIR CONDITIONING OVERVIEW	1	08/04/23	H	EMS-1	X		B	TO REV. H
5-11-AS350	AIR DISTRIBUTION	1	09/01/14	E	EMS-2/LAW ENFORCEMENT	X		B	TO REV. E

RSG PRODUCTS INC.
 440 West Ln
 Suite 100
 Saginaw TX 76131



Drawing List DL-9 Rev V
 August 04, 2023

DRAWING NUMBER	DRAWING TITLE	# OF PAGES	DRAWING DATE	REVISION	DESCRIPTION	AS 350	EC130B4	SIZE	NEW/RVSD
5-12-AS350	AIR DISTRIBUTION	1	09/01/14	E	MULTIPLE	X		B	TO REV. E
5-21-AS350	AIR DISTRIBUTION	1	08/04/23	H	EMS/ LAW ENFORCEMENT	X		B	TO REV. H
5-22-AS350	AIR DISTRIBUTION	1	09/01/14	C	ECL TOUR	X		B	TO REV. C
5-24-AS350	AIR DISTRIBUTION	1	09/01/14	B	LAW ENFORCEMENT	X		B	TO REV. B
5-25-AS350	AIR DISTRIBUTION	1	09/01/14	B	ECL TOUR 1	X		B	TO REV. B
5-26-AS350	AIR DISTRIBUTION	1	08/04/23	C	AEC BASIC CONFIGURATION	X		B	TO REV. C
5-1-EC130	AIR DISTRIBUTION	1	01/19/22	D	EC130		X	B	TO REV. D
5-2-EC130	AIR DISTRIBUTION	1	09/01/14	B	EC130		X	B	TO REV. B
5-3-EC130	AIR DISTRIBUTION	1	09/01/14	C	EC130		X	B	TO REV. C
5-4-EC130	A/C INSTURMENTATION CONFIGURATIONS	1	01/19/22	C	EC 130 B4		X	B	TO REV. C
6-2-AS350	COMPRESSOR INSTALL	1	01/19/22	G	HP COMPRESSOR	X		B	TO REV. G
6-3-AS350	COMPRESSOR INSTALL	1	08/04/23	F	HP COMPRESSOR NEWER B3,B4	X		B	TO REV. F
6-12-AS350	COMPRESSOR INSTALL	1	09/01/14	E	HP COMPRESSOR	X		B	TO REV. E
6-13-AS350	COMPRESSOR INSTALL	1	09/01/14	C	HP COMPRESSOR NEWER B3,B4	X	X	B	TO REV. C
6-21-AS350	COMPRESSOR INSTALL	1	09/01/14	E	BRACKET INSTALLATION	X		B	TO REV. E
6-22-AS350	COMPRESSOR INSTALL	1	09/01/14	C	HP COMPRESSOR NEWER B3,B4	X	X	B	TO REV. C
6-1-EC130	COMPRESSOR INSTALLATION	1	01/19/22	D	COMPRESSOR INSTALLATION		X	B	TO REV. D
6-2-EC130	COMPRESSOR INSTALLATION	1	09/01/14	B	COMPRESSOR INSTALLATION		X	B	TO REV. B
6-3-EC130	COMPRESSOR INSTALLATION	1	09/01/14	B	COMPRESSOR INSTALLATION		X	B	TO REV. B
6-5-EC130	BELT TENSION	1	09/01/14	B	EC 130 B4		X	B	TO REV. B
7-2-AS350	CONDENSER INSTALL	2	01/19/22	I	ADDED BLOWERS	X		B	TO REV. I
7-11-AS350	CONDENSER INSTALL	1	09/01/14	D	RIGHT SIDE BAGGAGE	X		B	TO REV. D
7-22-AS350	CONDENSER INSTALL	1	08/04/23	F	AFT CONDENSER INSTALL	X		B	TO REV. F
7-23-AS350	LH AIR EXIT DOUBLER INSTALL	1	08/04/23	F	AFT MOUNTED CONDENSER	X		B	TO REV. F
7-24-AS350	RH AIR EXIT DOUBLER INSTALL	1	08/04/23	F	AFT MOUNTED CONDENSER	X		B	TO REV. F
7-25-AS350	INSTALL AIR INLET DOUBLER LH	1	01/19/22	E	AFT MOUNTED CONDENSER	X		B	TO REV. E
7-26-AS350	INSTALL AIR INLET DOUBLER RH	1	09/01/14	D	AFT MOUNTED CONDENSER	X		B	TO REV. D
7-28-AS350	R.H. AIR EXIT DOUBLER INSTALL	1	08/04/23	C	AFT MOUNTED CONDENSER	X		B	TO REV. C
7-29-AS350	L.H. AIR EXIT DOUBLER INSTALL	1	08/04/23	C	AFT MOUNTED CONDENSER	X		B	TO REV. C
7-1-EC130	AFT CONDENSER INSTALLATION	1	09/01/14	B	AFT CONDENSER INSTALL		X	B	TO REV. B
7-2-EC130	AFT CONDENSER EXHAUST INSTALLATION	1	09/01/14	B	AFT CONDENSER INSTALL		X	B	TO REV. B
7-3-EC130	INSTALLATION AIR INLET DOUBLER	1	09/01/14	B	AIR INLET DOUBLER		X	B	TO REV. B
8-2-AS350	BAGGAGE COMPARTMENT MOD.	1 OF 2	08/0423	H	AIR INTAKE	X		B	TO REV. H
8-2-AS350	BAGGAGE COMPARTMENT MOD.	2 OF 2	08/04/23	G	AIR INTAKE	X		B	TO REV. G
8-11-AS350	BAGGAGE COMPARTMENT MOD.	1	01/19/22	F	EMS/ LAW ENFORCEMENT	X		B	TO REV. F
8-1-EC130	ELECTRIC BOX SHELF	1	09/01/14	C	EC130		X	B	TO REV. C
8-2-EC130	ELECT. BOX VERTICAL INSTALLATION	1	09/01/14	B	AS 350, EC 130 B4	X	X	B	TO REV. B
MANUFACTURE DRAWINGS									
020011-"O"	CONDENSOR COIL	1	09/01/14	D			X	B	TO REV. D
020024-"O"-1	CONDENSOR COIL	1	08/04/23	G		X		B	TO REV. G
020027-"O"-4	EVAPORATOR COIL	1	01/19/22	F		X	X	B	TO REV. F
020031-"O"-1	EVAPORATOR COIL	1	01/19/22	D		X	X	B	TO REV. D
020044-"O"	CONDENSOR COIL	1	08/04/23	E		X		B	TO REV. E
030011	LOUVER (MOD)	1	09/01/14	B		X		B	TO REV. B
030021-1	PLASTIC WEMAC, BLACK	1	01/19/22	C		X		B	TO REV. C
030021-2	WEMAC MODIFIED	1	09/01/14	C		X		B	TO REV. C
040001-1	BLOWER HOUSING	1	08/04/23	E		X		B	TO REV. E
040002-1	MOTOR COVER PLATE	1	09/01/14	D		X		B	TO REV. D
040002-4	BLOWER COVER MODIFICATION	1	09/01/14	C		X		B	TO REV. C
040003	VENTURI RING	1	01/19/22	E		X		B	TO REV. E
040003-1	VENTURI RING	1	09/01/14	D		X		B	TO REV. D
050007-1	SWITCH BUTTON "A/C-OFF-FAN"	1	09/01/14	C		X	X	B	TO REV. C
050007-3	SWITCH BUTTON	1	09/01/14	C		X	X	B	TO REV. C

RSG PRODUCTS INC.
 440 West Ln
 Suite 100
 Saginaw TX 76131



Drawing List DL-9 Rev V
 August 04, 2023

DRAWING NUMBER	DRAWING TITLE	# OF PAGES	DRAWING DATE	REVISION	DESCRIPTION	AS 350	EC130B4	SIZE	NEW/RVSD
050007-4	SWITCH BUTTON	1	09/01/14	C		X	X	B	TO REV. C
050052-1	BLOWER MOTOR MODIFIED, RH	1	08/04/23	D		X		B	TO REV. D
050084-6	7" VANE AXIAL BLOWER ASSEMBLY	3	09/01/14	E		X	X	B	TO REV. E
050143	5" VANE AXIAL BLOWER ASSEMBLY	1	09/01/14	C		X	X	B	TO REV. C
050145	MOTOR 28 VDC	1	09/01/14	B		X	X	B	TO REV. B
070069	STANDOFF	1	09/01/14	B		X	X	B	TO REV. B
080007	EVAPORATOR COVER SCREEN	1	09/01/14	C			X	B	TO REV. C
080008	FRESH AIR SCREEN	1	09/01/14	A			X	B	TO REV. A
080010	AFT RETURN AIR SCREEN	1	09/01/14	D			X	B	TO REV. D
080011	CONDENSER EXHAUST SCREEN	1	09/01/14	B			X	B	TO REV. B
080012	CONDENSER COVER SCREEN	1	09/01/14	B			X	B	TO REV. B
080020	SCREEN, CONDENSER INLET	1	09/01/14	D		X		B	TO REV. D
080021	SCREEN, CONDENSER EXHAUST	1	09/01/14	E		X		B	TO REV. E
080022	RETURN AIR SCREEN	1	09/01/14	E		X		B	TO REV. E
080022-1	RETURN AIR SCREEN	1	08/04/23	F		X		B	TO REV. F
080024	RETURN AIR SCREEN FWD. EVAP	1	09/01/14	E		X		B	TO REV. E
080035	SCREEN, CONDENSER INLET	1	09/01/14	D		X		B	TO REV. D
080039	AIR OUTLET SCREEN	1	09/01/14	D		X		B	TO REV. D
080040	AIR INLET SCREEN	1	09/01/14	E		X		B	TO REV. E
110008	AFT RETURN AIR SCREEN DOUBLER	1	09/01/14	A			X	B	TO REV. A
110009	SERVO COVER (FRESH AIR)	1	09/01/14	B			X	B	TO REV. B
110010	CONDENSER COVER	1	09/01/14	A			X	B	TO REV. A
110011	INNER EXHAUST RING CONDENSER	1	01/19/22	C			X	B	TO REV. C
110012	OUTER EXHAUST RING CONDENSER	1	01/19/22	C			X	B	TO REV. C
110013	NIPPLE (FRESH AIR)	1	09/01/14	A			X	B	TO REV. A
110015	RETURN AIR DUCT	1	08/04/23	D			X	B	TO REV. D
110016	AIR OUTLET ADAPTER LOWER	1	09/01/14	A			X	B	TO REV. A
110017	AIR OUTLET ADAPTER UPPER	1	09/01/14	A			X	B	TO REV. A
110018	INNER CLOSEOUT SKIRT	1	01/19/22	B			X	B	TO REV. B
110019	OUTER CLOSEOUT SKIRT	1	01/19/22	B			X	B	TO REV. B
120019	PLACARD, SWITCH	2	09/01/14	F		X		B	TO REV. F
120019-1	PLACARD AFT CABIN	1	09/01/14	F		X		B	TO REV. F
120020	PLACARD DUAL ROCKER SWITCH	1	09/01/14	B		X		B	TO REV. B
120021	PLACARD	1	09/01/14	E		X		B	TO REV. E
120024	PLACARD, AC MASTER	1	09/01/14	F		X		B	TO REV. F
120025	CIRCUIT BREAKER PLACARD	1	09/01/14	C		X		B	TO REV. C
120085-1	A/C MASTER PLACARD	1	09/01/14	A		X		B	TO REV. A
120087	BATTERY COVER DECAL	1	09/01/14	C		X		B	TO REV. C
120104	AIR DUCT CLOSURE DECAL	1	09/01/14	C		X		B	TO REV. C
120105	SWITCH PLACARD	1	09/01/14	C		X		B	TO REV. C
120105-1	SWITCH PLACARD	1	09/01/14	B		X	X	B	TO REV. B
120106	PLACARD, CIRCUIT BREAKER	1	09/01/14	C		X	X	B	TO REV. C
120106-1	PLACARD, CIRCUIT BREAKER	1	09/01/14	A			X	B	TO REV. A
120107	PLACARD, CIRCUIT BREAKER	1	09/01/14	E		X		B	TO REV. E
120117	REFRIGERANT LABEL	1	08/04/23	D		X	X	B	TO REV. D
120152	A/C MASTER PLACARD	1	09/01/14	A			X	B	TO REV. A
120214	FREON SERVICING STICKER	1	09/01/14	A		X	X	B	TO REV. A
250022	FWD. LOUVER HOUSING R.H. OUTER	1	09/01/14	E		X		B	TO REV. E
250022-1	FWD. LOUVER HOUSING R.H. INNER	1	01/19/22	F		X		B	TO REV. F
250022-2	FWD. LOUVER HOUSING R.H. INNER	1	09/01/14	D		X		B	TO REV. D
250036	FWD. LOUVER HOUSING L.H. OUTER	1	09/01/14	D		X		B	TO REV. D
250037	FWD. LOUVER HOUSING L.H. INNER	1	09/01/14	D		X		B	TO REV. D
250148	SPACER, AIR DUCT CLOSURE CHANNEL	1	09/01/14	D		X		B	TO REV. D
250148-1	SPACER AIR DUCT CLOSURE CHANNEL	1	09/01/14	D		X		B	TO REV. D



DRAWING NUMBER	DRAWING TITLE	# OF PAGES	DRAWING DATE	REVISION	DESCRIPTION	AS 350	EC130B4	SIZE	NEW/RVSD
250149	RETURN AIR DUCT	1	09/01/14	E		X		B	TO REV. E
250157	FWD. EVAPORATOR WYE INNER	1	09/01/14	E		X		B	TO REV. E
250158	FWD. EVAPORATOR WYE OUTER	1	09/01/14	D		X		B	TO REV. D
250160	AFT EVAPORATOR FAN ELBOW, INNER	1	09/01/14	B		X		B	TO REV. B
250161	AFT EVAPORATOR FAN ELBOW, OUTER	1	09/01/14	B		X		B	TO REV. B
250164	ELECTRICAL BOX COVER	1	09/01/14	G		X	X	B	TO REV. G
250165	AFT EVAP. HOUSING	1	09/01/14	C		X		B	TO REV. C
250165-1	AFT EVAP. HOUSING	1	09/01/14	C		X	X	B	TO REV. C
250166	RETURN AIR CONNECTOR	1	08/04/23	J		X		B	TO REV. J
250168	MOTOR SHROUD	1	09/01/14	F		X		B	TO REV. F
250168-1	MOTOR SHROUD	1	09/01/14	E		X		B	TO REV. E
250174	FWD. EVAP. ENCLOSURE	1	01/19/22	G		X		B	TO REV. G
250175	AFT EVAP HOUSING DRAIN	1	01/19/22	H		X	X	B	TO REV. H
250176-1	FWD.EVAP. FWD. ENCLOSURE	1	08/04/23	F		X		B	TO REV. F
250176-2	FEW. EVAP. REMOVABLE COVER	1	09/01/14	C		X		B	TO REV. C
250188	CONDENSER COVER, FORWARD	1	09/01/14	C		X		B	TO REV. C
250188-1	CONDENSER HOUSING CLOSEOUT	1	09/01/14	A		X		B	TO REV. A
250239-1	SCREEN RETAINER COND. EXHAUST	1	09/01/14	B		X		B	TO REV. B
250239-2	SCREEN RETAINER COND. EXHAUST	1	09/01/14	C		X		B	TO REV. C
250254	AIR TUBE	1	09/01/14	C		X		B	TO REV. C
250254-1	AIR TUBE	1	09/01/14	C		X		B	TO REV. C
250269	COND. HOUSING	1	01/19/22	F		X		B	TO REV. F
250272	AFT EVAP. ELBOW / INNER	1	09/01/14	E		X		B	TO REV. E
250273	AFT EVAP. ELBOW / OUTER	1	09/01/14	E		X		B	TO REV. E
250292	CONDENSER AIR INTAKE	1	01/19/22	D		X		B	TO REV. D
250299	VENT ADAPTER	1	09/01/14	E		X		B	TO REV. E
250301	AFT BAGGAGE CLOSEOUT PANEL	1	09/01/14	B		X		B	TO REV. B
250311	EVAP. MOTOR SHIM PLATE	1	09/01/14	B		X		B	TO REV. B
250314	INNER COVER	1	01/19/22	C		X		B	TO REV. C
250316-1	AIR OUTLET HOUSING, R.H.	1	09/01/14	C		X		B	TO REV. C
250319-1	AIR TUBE	1	09/01/14	C		X	X	B	TO REV. C
250324	AIR EXIT COLLAR	1	09/01/14	B		X		B	TO REV. B
250355	AFT EVAP HOUSING	1	09/01/14	E			X	B	TO REV. E
250370	FILLER	1	09/01/14	D		X	X	B	TO REV. D
250393	FWD EVAPORATOR ENCLOSURE	1	09/01/14	A			X	B	TO REV. A
250394	REMOVABLE COVER	1	08/04/23	B			X	B	TO REV. B
250402	AFT TRANSITION ELBOW	1	08/04/23	G		X		B	TO REV. G
250408	RIGHT HAND AIR TUBE	1	09/01/14	C		X		B	TO REV. C
250409	LEFT HAND AIR TUBE	1	09/01/14	B		X		B	TO REV. B
250431	AIR TUBE	1	09/01/14	B		X		B	TO REV. B
250440	AIR DISTRIBUTION MANIFOLD NOZZLE FWD	1	09/01/14	B			X	B	TO REV. B
250441	AIR DISTRIBUTION MANIFOLD LOWER	1	09/01/14	A			X	B	TO REV. A
250442	AIR DISTRIBUTION MANIFOLD UPPER	1	09/01/14	A			X	B	TO REV. A
250443	AIR DISTRIBUTION MANIFOLD NOZZLE, REAR	1	09/01/14	B			X	B	TO REV. B
250444	CONDENSER EXHAUST TUBE	1	09/01/14	A			X	B	TO REV. A
250445	AIR OUTLET LEFT SIDE	1	09/01/14	B			X	B	TO REV. B
250446	AIR OULET RIGHT SIDE	1	09/01/14	B			X	B	TO REV. B
250447	AIR OUTLET LEFT SIDE	1	09/01/14	A			X	B	TO REV. A
250448	AIR OUTLET MOUNT RIGHT SIDE	1	09/01/14	A			X	B	TO REV. A
250449	FWD EVAPORATOR HOUSING ASSY	1	09/01/14	B			X	B	TO REV. B
250450	EVAP COVER ASSEMBLY ENCLOSURE	1	09/01/14	A			X	B	TO REV. A
250458	AIR DISTRIBUTION BAFFLE	1	09/01/14	A			X	B	TO REV. A
260002	COND. MTG. ANGLE	1	09/01/14	D		X		B	TO REV. D
260004	COND. MTG. SUPPORT FWD	1	09/01/14	D		X		B	TO REV. D



DRAWING NUMBER	DRAWING TITLE	# OF PAGES	DRAWING DATE	REVISION	DESCRIPTION	AS 350	EC130B4	SIZE	NEW/RVSD
260005	COND. MTG. SUPPORT SPACER	1	08/04/23	F		X		B	TO REV. F
260006	COND. MTG. SUPPORT SPACER	1	01/19/22	E		X		B	TO REV. E
260007	COND. MOUNTING SUPPORT AFT	1	09/01/14	F		X		B	TO REV. F
260008	COND. MTG. SUPPORT SPACER	1	09/01/14	D		X		B	TO REV. D
260009	COND. MTG. SUPPORT SPACER	1	08/04/23	G		X		B	TO REV. G
260020	FAN CHANNEL BASE ANGLE	1	09/01/14	D		X		B	TO REV. D
260123-2	MOUNT RECEIVER / DRIER	2	08/04/23	D		X	X	B	TO REV. D
260148	CONDENSER FAN MOUNT	1	08/04/23	E		X		B	TO REV. E
260148-3	CONDENSER FAN MOUNT	1	08/04/23	D		X		B	TO REV. D
260216	AIR DUCT CLOSURE CHANNEL	1	09/01/14	F		X		B	TO REV. F
260234	AIR DUCT CLOSURE INSERT	1	09/01/14	E		X		B	TO REV. E
260321	CONDENSER FAN MOUNT RING	1	09/01/14	E		X		B	TO REV. E
260322	DOUBLER, RETURN AIR	1	08/04/23	D		X		B	TO REV. D
260322-1	DOUBLER, RETURN AIR	1	08/04/23	F		X		B	TO REV. F
260322-2	ANGLE	1	08/04/23	F		X		B	TO REV. F
260325	AFT. EVAP. CLOSEOUT, FWD.	1	08/04/23	F		X	X	B	TO REV. F
260325-1	AFT. EVAP. CLOSEOUT, FWD.	1	08/04/23	B		X	X	B	TO REV. B
260326	EVAP. CLOSEOUT, AFT.	1	08/04/23	F		X	X	B	TO REV. F
260327	AFT EVAP. CLOSEOUT INBOARD	1	08/04/23	F		X	X	B	TO REV. F
260327-1	AFT EVAP. CLOSEOUT OUTBOARD	1	08/04/23	F		X	X	B	TO REV. F
260328-1	AFT EVAP. FAN DOUBLER	1	08/04/23	F		X		B	TO REV. F
260333	BATTERY COMP. SHELF	1	09/01/14	F		X		B	TO REV. F
260335	BATTERY COMPARTMENT SHELF ANGLE FWD	1	09/01/14	E		X		B	TO REV. E
260339	ANGLE BATTERY COVER	1	08/04/23	E		X		B	TO REV. E
260343	ELECTRICAL BOX BODY	1	08/04/23	E		X		B	TO REV. E
260343-1	ELECTRICAL BOX BODY	1	08/04/23	E		X	X	B	TO REV. E
260344	ELECTRICAL BOX SHIM	1	08/04/23	E		X	X	B	TO REV. E
260344-1	ELEC. BOX ANGLE	1	08/04/23	E		X	X	B	TO REV. E
260350	UPPER CLOSEOUT, AFT EVAPORATOR	1	08/04/23	F		X	X	B	TO REV. F
260351	AFT SWITCH BACKING PLATE	1	08/04/23	F		X		B	TO REV. F
260354	ANGLE, RETURN AIR CONNECTOR	1	08/04/23	F		X		B	TO REV. F
260369	HOSE DOUBLER, BAG COMP.	1	09/01/14	G		X		B	TO REV. G
260372	FWD. EVAP. ANGLE	1	09/01/14	D		X		B	TO REV. D
260373	DOUBLER	1	08/04/23	E		X		B	TO REV. E
260373-1	DOUBLER	1	08/04/23	G		X	X	B	TO REV. G
260486-1	FWD EVAP SUPPORT VERTICAL	1	09/01/14	C			X	B	TO REV. C
260862	FILLER	1	08/04/23	D		X		B	TO REV. D
260863	FWD. EVAP. MOUNT	1	08/04/23	E		X		B	TO REV. E
260863-1	FWD. EVAP. MOUNT	1	08/04/23	C		X		B	TO REV. C
260915	RING	1	08/04/23	D			X	B	TO REV. D
260947	TURNING VANE	1	08/04/23	D		X		B	TO REV. D
260951	ANGLE	1	01/19/22	D		X		B	TO REV. D
260951-1	ANGLE	1	01/19/22	D		X		B	TO REV. D
260952	CLIP	1	08/04/23	D		X		B	TO REV. D
260953	CLIP	1	08/04/23	D		X		B	TO REV. D
261006	ANGLE	1	09/01/14	C		X		B	TO REV. C
261006-1	ANGLE R.H. LOWER WEMAC MOUNT	1	09/01/14	B		X		B	TO REV. B
261006-2	ANGLE	1	09/01/14	B		X		B	TO REV. B
261006-3	ANGLE	1	08/04/23	B		X		B	TO REV. B
261007	BUSHING, SD-507	1	01/19/22	E		X	X	B	TO REV. E
261008	BUSHING, SD-507	1	08/04/23	F		X	X	B	TO REV. F
261012	STRINGER, OUTBOARD	1	08/04/23	C		X		B	TO REV. C
261013	L/H AIR INLET DOUBLER	1	08/04/23	D		X		B	TO REV. D
261013-2	R/H AIR INLET DOUBLER	1	08/04/23	C		X		B	TO REV. C



DRAWING NUMBER	DRAWING TITLE	# OF PAGES	DRAWING DATE	REVISION	DESCRIPTION	AS 350	EC130B4	SIZE	NEW/RVSD
261014	STRAP	1	08/04/23	C		X		B	TO REV. C
261071	CLOSEOUT PANEL	1	08/04/23	E		X		B	TO REV. E
261072	CLOSEOUT PANEL DOUBLER	1	08/04/23	E		X	X	B	TO REV. E
261074	PLATE, BACK	1	08/04/23	D		X		B	TO REV. D
261075	CLOSEOUT, TOP/BOTTOM	1	08/04/23	C		X		B	TO REV. C
261076	FILLER	1	08/04/23	D		X		B	TO REV. D
261077	ANGLE CLOSEOUT	1	08/04/23	D		X		B	TO REV. D
261078	CLOSEOUT, SIDE	1	08/04/23	C		X		B	TO REV. C
261079	MOTOR MOUNT	1	08/04/23	E		X		B	TO REV. E
261080	CHANNEL, SUPPORT, FORWARD	1	08/04/23	C		X		B	TO REV. C
261081	CHANNEL, SUPPORT, AFT	1	08/04/23	C		X		B	TO REV. C
261082	ANGLE	1	08/04/23	C		X		B	TO REV. C
261083	BAFFLE	1	08/04/23	C		X		B	TO REV. C
261086-1	SWITCH PLATE	1	09/01/14	B		X	X	B	TO REV. B
261086-2	SWITCH PLATE	1	09/01/14	D		X		B	TO REV. D
261087	ANGLE	1	08/04/23	C		X		B	TO REV. C
261089-1	WEMAC MOUNT	1	08/04/23	D		X		B	TO REV. D
261094	FILLER STRIP UPPER	1	08/04/23	C		X		B	TO REV. C
261095	FILLER STRIP LOWER	1	08/04/23	C		X		B	TO REV. C
261096	ANGLE UPPER RH	1	08/04/23	D		X		B	TO REV. D
261097	ANGLE UPPER LH	1	08/04/23	D		X		B	TO REV. D
261098	ANGLE LOWER RH	1	08/04/23	D		X		B	TO REV. D
261099	ANGLE LOWER LH	1	08/04/23	D		X		B	TO REV. D
261100	RH AIR EXIT DOUBLER	1	08/04/23	D		X		B	TO REV. D
261100-1	RH AIR EXIT DOUBLER	2	08/04/23	B		X		B	TO REV. B
261101	LH AIR EXIT DOUBLER	1	08/04/23	D		X		B	TO REV. D
261101-1	LH AIR EXIT DOUBLER	2	08/04/23	B		X		B	TO REV. B
261107	RELAY STRAP	1	08/04/23	D		X	X	B	TO REV. D
261107-2	RELAY STRAP	1	09/01/14	A			X	B	TO REV. A
261176	FAN BLADE HUB	1	09/01/14	C		X	X	B	TO REV. C
261299	TRANSITION ELBOW STRAP	1	08/04/23	E		X		B	TO REV. E
261333HP	VENT HOUSING	2	08/04/23	B		X			TO REV. B
261335HP	VENT MOUNT	1	09/01/14	NC		X			TO REV. NC
261336HP	BACK PLATE	1	09/01/14	NC		X			TO REV. NC
261346HP	MOUNTING PLATE	1	09/01/14	NC		X			TO REV. NC
261347HP	RELAY BRACKET	1	09/01/14	NC		X			TO REV. NC
261348HP	DZUS RAIL, SWITCH ASSEMBLY	1	09/01/14	NC		X			TO REV. NC
261351	CLIP (FRESH AIR DOOR)	1	09/01/14	B			X	B	TO REV. B
261352	HINGE DOOR	1	09/01/14	C			X	B	TO REV. C
261353	SERVO MOUNT	1	09/01/14	B			X	B	TO REV. B
261354	DOOR	1	09/01/14	B			X	B	TO REV. B
261355	FWD EVAP SUPPORT LOWER	1	01/19/22	B			X	B	TO REV. B
261356	FWD EVAP SUPPORT UPPER	1	01/19/22	B			X	B	TO REV. B
261357	FWD EVAP MOUNT SHIM	1	09/01/14	B			X	B	TO REV. B
261358	NUT PLATE STRIP FORWARD EVAPORATOR	1	09/01/14	A			X	B	TO REV. A
261359	DOOR HANDLE	1	09/01/14	B			X	B	TO REV. B
261360	FWD BRACE CONDENSER	1	09/01/14	A			X	B	TO REV. A
261361	AFT BRACE CONDENSER	1	08/04/23	C			X	B	TO REV. C
261362	MOUNT PLATE	1	09/01/14	A			X	B	TO REV. A
261363	FWD EVAP MOUNT PLATE	1	08/04/23	B			X	B	TO REV. B
261364	CONDENSER MOUNT LEFT & RIGHT	1	09/01/14	A			X	B	TO REV. A
261365	SERVO MOUNT PLATE	1	09/01/14	B			X	B	TO REV. B
261366	CONDENSER BODY	1	09/01/14	A			X	B	TO REV. A
261367	CONDENSER ANGLE LEFT	1	08/04/23	C			X	B	TO REV. C



DRAWING NUMBER	DRAWING TITLE	# OF PAGES	DRAWING DATE	REVISION	DESCRIPTION	AS 350	EC130B4	SIZE	NEW/RVSD
261367-1	CONDENSER ANGLE RIGHT	1	08/04/23	B			X	B	TO REV. B
261368	AFT MANIFOLD BRACKET	1	09/01/14	B			X	B	TO REV. B
261369	AIR VALVE BODY	1	08/04/23	C			X	B	TO REV. C
261370	R.H. FAN DOUBLER	1	09/01/14	B			X	B	TO REV. B
261371	R.H. FAN DOUBLER SHIM	1	09/01/14	B			X	B	TO REV. B
261374	AFT MANIFOLD BRACKET BASE	1	09/01/14	A			X	B	TO REV. A
261375	ELECTRICAL BOX SHELF	1	09/01/14	B			X	B	TO REV. B
261377	AC MASTER PLATE	1	09/01/14	A			X	B	TO REV. A
261511	L.H. STRAP	1	08/04/23	B		X		B	TO REV. B
261512	R.H. STRAP	1	08/04/23	B		X		B	TO REV. B
261513	FILLER	1	08/04/23	B		X		B	TO REV. B
261585	RESISTOR MOUNT	1	09/01/14	A		X	X	B	TO REV. A
300066	PULLEY MODIFIED	1	09/01/14	C		X		B	TO REV. C
300066-1	PULLEY MODIFIED	1	09/01/14	A		X		B	TO REV. A
300067	COMPRESSOR STAND OFF	1	01/19/22	G		X		B	TO REV. G
300067-1	COMPRESSOR STAND OFF	1	01/19/22	B		X	X	B	TO REV. B
300068-1	COMPRESSOR MOUNT, ARM	1	09/01/14	C		X		B	TO REV. C
300068-2	ARM, COMPRESSOR MOUNT	1	09/01/14	B		X	X	B	TO REV. B
300068-3	ARM COMPRESSOR MOUNT	1	09/01/14	D		X	X	B	TO REV. D
300069-1	ARM, COMP. MT.	1	09/01/14	C		X	X	B	TO REV. C
300069-2	ARM COMPRESSOR MOUNT	1	09/01/14	D		X	X	B	TO REV. D
300070-1	GUSSET	1	09/01/14	D		X	X	B	TO REV. D
300095	COMPRESSOR PIN	1	09/01/14	D		X	X	B	TO REV. D
300329	SPACER TUBE	1	09/01/14	E		X	X	B	TO REV. E
300355	PULLEY MODIFIED	1	09/01/14	D		X		B	TO REV. D
300355-2	PULLEY MODIFIED	1	08/04/23	F		X		B	TO REV. F
300363	COMPRESSOR HOUSING SUPPORT	1	09/01/14	D		X		B	TO REV. D
300363-1	COMP. HOUSING SUPPORT LOWER	1	09/01/14	A		X	X	B	TO REV. A
300363-2	COMPRESSOR SHIM UPPER	1	09/01/14	A		X	X	B	TO REV. A
300364	COMPRESSOR HOUSING BUSHING	1	01/19/22	D		X	X	B	TO REV. D
300396	5 GROOVE PULLEY	1	08/04/23	D			X	B	TO REV. D
490015	BLOWER HOUSING ASSY	1	09/01/14	C		X		B	TO REV. C
490015-1	BLOWER HOUSING ASSY	1	08/04/23	F		X		B	TO REV. F
490016-1	FWD. BLOWER ASSEMBLY	1	08/04/23	E		X		B	TO REV. E
490017-1	AFT EVAPORATOR FAN	1	08/04/23	G		X		B	TO REV. G
500001	LEFT SIDE AIR OUTLET ASSEMBLY	1	09/01/14	B			X	B	TO REV. B
500002	RIGHT SIDE AIR OUTLET ASSEMBLY	1	09/01/14	B			X	B	TO REV. B
500008-1	LOUVER ASSEMBLY, RH	1	09/01/14	E		X		B	TO REV. E
500010-1	LOUVER HOUSING ASSY. R.H.	1	09/01/14	F		X		B	TO REV. F
500011-1	LOUVER HOUSING ASSY. L.H.	1	09/01/14	F		X		B	TO REV. F
500018	AIR OUTLET ASSY, RH	1	01/19/22	E		X		B	TO REV. E
500018-1	AIR OUTLET ASSY, RH	1	01/19/22	D		X		B	TO REV. D
500018-2	AIR OUTLET ASSY, L/H	1	09/01/14	D		X		B	TO REV. D
500033	INNER COVER ASSEMBLY	1	09/01/14	B		X		B	TO REV. B
510007	AFT. CHANNEL COND. SUPPORT ASSEMBLY	1	08/04/23	E		X		B	TO REV. E
510008	FWD COND. CHANNEL ASSEMBLY	1	01/19/22	E		X		B	TO REV. E
510091	COND. FAN MOUNT RING ASSEMBLY	1	09/01/14	E		X		B	TO REV. E
510091-2	COND. FAN MOUNT RING ASSY	1	09/01/14	C		X	X	B	TO REV. C
510092	AIR DUCT CLOSURE ASSEMBLY	1	09/01/14	C		X		B	TO REV. C
510099	UPPER CLOSEOUT, AFT EVAPORATOR ASSY	1	09/01/14	D		X	X	B	TO REV. D
510200	BOX ASSY	1	09/01/14	D		X		B	TO REV. D
510200-1	BOX ASSY	1	09/01/14	C		X	X	B	TO REV. C
510233	RING ASSEMBLY	1	09/01/14	B			X	B	TO REV. B
510259	AIR OUTLET ASSEMBLY	1	09/01/14	D		X		B	TO REV. D



DRAWING NUMBER	DRAWING TITLE	# OF PAGES	DRAWING DATE	REVISION	DESCRIPTION	AS 350	EC130B4	SIZE	NEW/RVSD
510259-1	AIR OUTLET ASSEMBLY, LOWER	1	09/01/14	C		X		B	TO REV. C
510259-2	AIR OUTLET ASSEMBLY	1	09/01/14	C		X		B	TO REV. C
510259-3	AIR OUTLET ASSEMBLY	1	09/01/14	A		X		B	TO REV. A
510261	ANGLE RETURN AIR CONECTOR ASSY	1	09/01/14	C		X		B	TO REV. C
510265	BATTERY COMP. SHELF ANGLE FWD ASSY.	1	09/01/14	C		X		B	TO REV. C
510266	RETURN AIR DOUBLER ASSEMBLY	1	09/01/14	C		X		B	TO REV. C
510283	CLOSEOUT, BOTTOM ASSEMBLY	1	09/01/14	C		X		B	TO REV. C
510284	CLOSEOUT, SIDE ASSEMBLY	1	09/01/14	C		X		B	TO REV. C
510372	CLIP ASSEMBLY (FRESH AIR)	1	09/01/14	A			X	B	TO REV. A
510373	NUT PLATE STRIP ASSY FWD EVAP	1	09/01/14	A			X	B	TO REV. A
510374	SERVO MOUNT SHELF ASSY	1	08/04/23	C			X	B	TO REV. C
510375	SERVO MOUNT FRAME ASSEMBLY	1	09/01/14	A			X	B	TO REV. A
510376	ASSEMBLY (FRESH AIR DOOR)	1	08/04/23	C			X	B	TO REV. C
510377	FRESH AIR ASSY (METAL)	1	09/01/14	B			X	B	TO REV. B
510378HP	OVERLAY ASSEMBLY	1	09/01/14	NC		X			TO REV. NC
510379	FWD EVAP SUPPORT ASSY UPPER	1	09/01/14	A			X	B	TO REV. A
510380	FWD EVAP SUPPORT ASSY LOWER	1	09/01/14	A			X	B	TO REV. A
510381	MOUNT PLATE ASSEMBLY	1	01/19/22	B			X	B	TO REV. B
510384	ELECT BOX MOUNT ASSEMBLY	1	09/01/14	A		X	X	B	TO REV. A
510463	RESISTOR MOUNT ASSEMBLY	1	09/01/14	A		X	X	B	TO REV. A
520001	CONDENSER EXHAUST ASSEMBLY	1	09/01/14	A			X	B	TO REV. A
520002	AIR DISTRIBUTION MANIFOLD ASSY	1	08/04/23	D			X	B	TO REV. D
520003-130	AIR DIST. MANIFOLD ASSY COMP	1	09/01/14	C			X	B	TO REV. C
520004-130	CONDENSER ASSY	1	09/01/14	B			X	B	TO REV. B
520005	MANIFOLD NOZZLE ASSEMBLY	1	08/04/23	E			X	B	TO REV. E
520032-1	CONDENSER EXHAUST ELBOW	1	09/01/14	B		X		B	TO REV. B
520033	EVAPORATOR WYE ASSEMBLY	1	09/01/14	C		X		B	TO REV. C
520033-1	FWD EVAP WYE ASSY	1	08/04/23	D		X		B	TO REV. D
520034	AFT EVAPORATOR FAN ELBOW ASSY.	1	09/01/14	B		X		B	TO REV. B
520036-3	AFT TRANSITION ELBOW ASSEMBLY	1	08/04/23	E		X		B	TO REV. E
520052-1	SCREEN ASSEMBLY COND. EXHAUST	1	09/01/14	C		X		B	TO REV. C
520052-2	SCREEN ASSY- COND. EXHAUST	1	09/01/14	C		X		B	TO REV. C
520061	AFT EVAPORATOR FAN ELBOW ASSY.	1	09/01/14	D		X		B	TO REV. D
520071	CONDENSER AIR INTAKE ASSY	1	09/01/14	B		X		B	TO REV. B
520071-1	CONDENSER AIR INTAKE ASSY	1	08/04/23	D		X		B	TO REV. D
520073	FWD. EVAP. REMOVABLE COVER ASSY.	1	08/04/23	C		X		B	TO REV. C
520120	AIR OUTLET ADAPTER ASSEMBLY	1	09/01/14	B			X	B	TO REV. B
520156HP	AIR VENT ASSEMBLY L.H.	1	08/04/23	A		X			TO REV. A
520157HP	AIR VENT ASSEMBLY R.H.	1	09/01/14	NC		X			TO REV. NC
530027-1	SD-505 COMPRESSOR MOUNT ASSY	1	09/01/14	D		X		B	TO REV. D
530027-2	SD-505 COMPRESSOR MOUNT ASSY	1	09/01/14	B		X		B	TO REV. B
530027-3	COMPRESSOR MOUNT ASSY	1	09/01/14	F		X	X	B	TO REV. F
530084	VENTURI RING ASSY.	1	09/01/14	B		X		B	TO REV. B
530100	STRAP, HOUSING MOD ASSY	1	09/01/14	D		X		B	TO REV. D
530100-1	STRAP, HOUSING MOD ASSY	1	09/01/14	B		X	X	B	TO REV. B
540007	FRESH AIR INTAKE ASSEMBLY	2	08/04/23	E			X	B	TO REV. E
540008	FRESH AIR SERVO WIRING DIAGRAM	1	09/01/14	B			X	B	TO REV. B
540008-1	FRESH AIR SERVO CIRCUIT BOARD ASSY/DIAG	1	01/19/22	C			X	B	TO REV. C
540009	ELECTRICAL BOX ASSY	1	08/04/23	E			X	B	TO REV. E
540010	HARNESS ASSEMBLY	1	09/01/14	A			X	B	TO REV. A
540011	SWITCH ASSEMBLY	1	01/19/22	C			X	B	TO REV. C
540012	PANEL MOUNT SWITCH ASSEMBLY	1	09/01/14	A			X	B	TO REV. A
540020	RESISTOR ASSEMBLY	1	09/01/14	A		X	X	B	TO REV. A
540028-C	ELECTRICAL BOX ASSEMBLY	1	09/01/14	C		X		B	TO REV. C



DRAWING NUMBER	DRAWING TITLE	# OF PAGES	DRAWING DATE	REVISION	DESCRIPTION	AS 350	EC130B4	SIZE	NEW/RVSD
540028-"C"-1	ELECTRICAL BOX ASSEMBLY	1	09/01/14	B		X		B	TO REV. B
540028-"C"-1-A	ELECTRICAL BOX ASSEMBLY	1	08/04/23	F		X		B	TO REV. F
540028-"C"-2	ELECTRICAL BOX ASSEMBLY	1	09/01/14	C		X		B	TO REV. C
540028-"C"-2-A	ELECTRICAL BOX ASSEMBLY	2	08/04/23	F		X		B	TO REV. F
540044	HARNESS ASSEMBLY	1	09/01/14	C		X		B	TO REV. C
540044-2	HARNESS ASSEMBLY	1	09/01/14	C		X		B	TO REV. C
540044-3	HARNESS ASSEMBLY	1	08/04/23	J		X		B	TO REV. J
540044-4	HARNESS ASSEMBLY	1	08/04/23	H		X		B	TO REV. H
540044-5	HARNESS ASSEMBLY	2	01/19/22	F		X		B	TO REV. F
540044-6	HARNESS ASSEMBLY	1	01/19/22	E		X		B	TO REV. E
540044-7	HARNESS ASSEMBLY	1	09/01/14	C		X		B	TO REV. C
540044-8	INSTRUMENT PANEL SWITCH	1	01/19/22	D		X		B	TO REV. D
540044-9	5 AMP CIRCUIT BREAKER ASSY	1	09/01/14	B		X		B	TO REV. B
540045-1	HARNESS ASSEMBLY	1	01/19/22	D		X	X	B	TO REV. D
540056	ELECT. BOX VERTICAL MOUNTING ASSY	1	09/01/14	A		X	X	B	TO REV. A
540089	AFT EVAPORATOR SWITCH ASSY	1	01/19/22	E		X		B	TO REV. E
550002-"O"	COND. COIL ASSY	1	09/01/14	E		X		B	TO REV. E
550002-"O"-1	COND. COIL ASSY	1	09/01/14	C		X		B	TO REV. C
550003-"O"	AFT CONDENSER ASSY	3	01/19/22	C			X	B	TO REV. C
550004-"O"	CONDENSER COIL ASSY	1	09/01/14	A			X	B	TO REV. A
550007-1	COND. ASSEMBLY	1	08/04/23	G		X		B	TO REV. G
550022	COND. ASSEMBLY	1	08/04/23	J		X		B	TO REV. J
560004	FORWARD EVAPORATOR ASSEMBLY	2	09/01/14	B			X	B	TO REV. B
560005	FWD EVAPORATOR COIL ASSEMBLY	1	08/04/23	C			X	B	TO REV. C
560006	FWD EVAP COIL HOUSING ASSY	1	01/19/22	C			X	B	TO REV. C
560010-"O"-5	AFT EVAPORATOR ASSEMBLY	1	08/04/23	F		X		B	TO REV. F
560012-"O"-3	AFT EVAPORATOR COIL ASSEMBLY	1	01/19/22	E		X	X	B	TO REV. E
560016-"O"	COIL ASSEMBLY FWD	1	09/01/14	B		X		B	TO REV. B
560016-"O"-1	AFT EVAPORATOR ASSEMBLY	1	08/04/23	D			X	B	TO REV. D
560025-"O"	FWD. EVAP. ASSY.	1	08/04/23	G		X		B	TO REV. G
560052-"O"	COIL ASSY FORWARD	1	01/19/22	E		X		B	TO REV. E
570020-"O"-A	HOSE ASSEMBLY, COND. TO REC/ DRIER	1	09/01/14	C		X		B	TO REV. C
570021-"O"-A	HOSE ASSY. FWD. EVAP. TO AFT EVAP	1	09/01/14	C		X		B	TO REV. C
570022-"O"-A	HOSE ASSY. EVAP. TO EVAP.	1	09/01/14	C		X		B	TO REV. C
570023-"O"-A	HOSE ASSEMBLY, COMP. SUCTION	1	09/01/14	C		X		B	TO REV. C
570024-"O"-A	HOSE ASSY, COMPRESSOR DISCHARGE	1	09/01/14	E		X		B	TO REV. E
570067-"O"-A	HOSE ASSY, COND TO REC/DRIER	1	09/01/14	D		X		B	TO REV. D
570070-"O"-A	HOSE ASSY, COMPRESSOR TO COND	1	09/01/14	D		X	X	B	TO REV. D
570071-"O"-A	HOSE ASSY, FWD EVAP. TO AFT EVAP.	1	09/01/14	B		X		B	TO REV. B
570072-"O"-A	HOSE ASSY, EVAP TO EVAP	1	01/19/22	E		X		B	TO REV. E
570087-"O"-A	HOSE ASS, FWD EVAP. TO AFT EVAP	1	01/19/22	F		X		B	TO REV. F
570103	HIGH PRESSURE HOSE, #6 ASSEMBLY	1	09/01/14	B			X	B	TO REV. B
570104	CONDENSER TO REC DRYER #6 ASSY	1	09/01/14	B			X	B	TO REV. B
570105	RETURN HOSE #10 ASSEMBLY	1	09/01/14	B			X	B	TO REV. B
580000	5" HUB & PROPELLER ASSY	1	09/01/14	C		X		B	TO REV. C
590001-1-"O"	SD-505 COMPRESSOR ASSEMBLY	1	09/01/14	C		X		B	TO REV. C
590008	COMPRESSOR ASSEMBLY	1	08/04/23	E		X	X	B	TO REV. E
590008-1	COMPRESSOR ASSEMBLY	1	08/04/23	D		X	X	B	TO REV. D
590010	MOTOR 28 VDC MODIFIED	1	09/01/14	D		X		B	TO REV. D
600002	FRESH AIR ASSMBLY	1	01/19/22	C			X	B	TO REV. C
04-130-21-101	COMPRESSOR MOUNT BRACKET	1	05/18/12	A		X	X	B	TO REV. A
04-130-21-102	COMPRESSOR MOUNT TENSION BOLT	1	01/19/22	A		X	X	B	TO REV. A
04-130-21-104	JAM NUT, DRILLED	1	04/30/12	NC		X	X	B	TO REV. NC
04-130-21-105	COMPRESSOR CLAMP	1	04/30/12	NC		X	X	B	TO REV. NC

RSG PRODUCTS INC.
 440 West Ln
 Suite 100
 Saginaw TX 76131



Drawing List DL-9 Rev V
 August 04, 2023

DRAWING NUMBER	DRAWING TITLE	# OF PAGES	DRAWING DATE	REVISION	DESCRIPTION	AS 350	EC130B4	SIZE	NEW/RVSD
04-130-21-107	HOSE DISCONNECT BRACKET	1	04/30/12	NC		X	X	B	TO REV. NC
IFSS 050084-7-2	7" DC BRUSHLESS BLOWER ASSEMBLY	1	01/19/22	E		X	X	B	TO REV. E
IFSS 050084-7-3	7" DC BRUSHLESS BLOWER ASSEMBLY	1	01/19/22	E		X	X	B	TO REV. E
IFSS 261323	3-PIN CONNECTOR W/COLLAR ASSY	1	01/19/22	C		X	X	B	TO REV. C
IFSS 540126-1	CONTROLLER ASSEMBLY	1	01/19/22	C		X	X	B	TO REV. C
IFSS 261319	CURVED BASE MOUNT	1	01/19/22	B		X	X	B	TO REV. B
IFSS 261314-1	CURVED BASE MOUNT ASSY	1	01/19/22	B		X	X	B	TO REV. B
IFSS 040021	7" BLOWER HOUSING, STEEL	1	01/19/22	C		X	X	B	TO REV. C
IFSS 050193	MOOG DC BRUSHLESS MOTOR	3	01/19/22	B		X	X	B	TO REV. B
IFSS 040020	7" HOUSING, SINGLE FLANGE WITH BEAD, STEEL	1	08/04/23	D		X	X	B	TO REV. D
IFSS 040019	7" PROPELLER - MOOG	1	01/19/22	B		X	X	B	TO REV. B
IFSS 050176-1	7" PROPELLER HUB	1	01/19/22	B		X	X	B	TO REV. B
IFSS 540131	CONTROLLER	1	01/19/22	B		X	X	B	TO REV. B
IFSS 510362	MOUNTING PLATE ASSEMBLY	1	01/19/22	B		X	X	B	TO REV. B
IFSS 261322	FLAT CONTROLLER MOUNTING PLATE	1	09/01/14	A		X	X	B	TO REV. A
IFSS 110008	CONTROLLER COVER	1	09/01/14	A		X	X	B	TO REV. A
IFSS 300398	PROP ADAPTER	1	09/01/14	A		X	X	B	TO REV. A
IFSS 300396	KEY	1	09/01/14	A		X	X	B	TO REV. A
IFSS 261318	STANDOFF	1	09/01/14	A		X	X	B	TO REV. A
IFSS 120128	FAA/PMA PLACARD	1	09/01/14	A		X	X	B	TO REV. A
IFSS 120123	MANUFACTURERS PLACARD	1	09/01/14	A		X	X	B	TO REV. A
IFSS 120124	MANUFACTURERS PLACARD	1	09/01/14	A		X	X	B	TO REV. A
IFSS 050143-2 DCB	5" DC BRUSHLESS 2 SPEED BLOWER ASSEMBLY	1	08/04/23	C		X	X	B	TO REV. C
IFSS 050143-3 DCB	5" DC BRUSHLESS SINGLE SPEED BLOWER ASSE	1	08/04/23	C		X	X	B	TO REV. C
IFSS 250371	PROPELLER	2	08/04/23	A		X	X	B	TO REV. A
IFSS 580000	5" HUB & PROPELLER ASSY	2	08/04/23	A		X	X	B	TO REV. A
IFSS 540125	CONTROLLER/COVER ASSEMBLY	1	08/04/23	A		X	X	B	TO REV. A
IFSS 261176	HUB, FAN BLADE	2	08/04/23	B		X	X	B	TO REV. B
IFSS 050187	CONTROLLER	1	08/04/23	B		X	X	B	TO REV. B
IFSS 261306	AFT MOTOR COVER	1	08/04/23	A		X	X	B	TO REV. A
IFSS 040016	5" AXIAL HOUSING	1	08/04/23	A		X	X	B	TO REV. A
IFSS 040017	STANDOFF	1	08/04/23	A		X	X	B	TO REV. A
PURCHASE PARTS DRAWINGS									
010001-1	COMPRESSOR SD-505	1	09/01/14	C		X		B	TO REV. C
010001-1-O	COMPRESSOR SD-505	1	09/01/14	C		X		B	TO REV. C
010001-2-O	COMPRESSOR SD-505	1	09/01/14	B		X		B	TO REV. B
010001-3-O	COMPRESSOR SD-505	1	09/01/14	C		X		B	TO REV. C
010004	COMPRESSOR SD-507 (SE-507)	1	09/01/14	B		X	X	B	TO REV. B
010004-1	COMPRESSOR ASSY SD-507	1	09/01/14	B		X	X	B	TO REV. B
010004-3	COMPRESSOR	1	08/04/23	C		X		B	TO REV. C
010011	BEARING	1	09/01/14	B		X	X	B	TO REV. B
010012	CLUTCH PLATE SD-505	1	09/01/14	B		X	X	B	TO REV. B
010013	CLUTCH PLATE, SD-505	1	09/01/14	B		X	X	B	TO REV. B
010014	CLUTCH PLATE, SD-507	1	09/01/14	B		X	X	B	TO REV. B
010015	CLUTCH PLATE, SD-507	1	09/01/14	C		X	X	B	TO REV. C
030010	LOUVER	1	09/01/14	B		X		B	TO REV. B
030010-1	LOUVER	1	09/01/14	B		X		B	TO REV. B
030012-1	WEMAC-BLACK	1	09/01/14	B		X	X	B	TO REV. B
030012-3	WEMAC, BLACK WITH ADAPTER	1	09/01/14	A		X		B	TO REV. A
030021	PLASTIC WEMAC, BLACK	1	09/01/14	B		X	X	B	TO REV. B
040001	BLOWER HOUSING	1	09/01/14	C		X		B	TO REV. C
040002	COVER PLATE	1	09/01/14	C		X		B	TO REV. C



DRAWING NUMBER	DRAWING TITLE	# OF PAGES	DRAWING DATE	REVISION	DESCRIPTION	AS 350	EC130B4	SIZE	NEW/RVSD
040003	VENTURI RING	1	09/01/14	D		X		B	TO REV. D
040004-8	FAN WHEEL CW	1	08/04/23	D		X		B	TO REV. D
040004-9	FAN WHEEL CW	1	09/01/14	B		X		B	TO REV. B
050000	SWITCH W/BUTTON	1	09/01/14	D		X	X	B	TO REV. D
050001	SWITCH W/O BUTTON	1	09/01/14	C		X	X	B	TO REV. C
050002	SWITCH	1	09/01/14	C		X	X	B	TO REV. C
050006	SWITCH W/O BUTTON	1	09/01/14	D		X	X	B	TO REV. D
050006-2	SWITCH W/BUTTON	1	09/01/14	D		X	X	B	TO REV. D
050007	SWITCH BUTTON	1	09/01/14	C		X	X	B	TO REV. C
050008	RELAY 24VDC SPST	1	09/01/14	C		X	X	B	TO REV. C
050019-7	RELAY 24VDC SPST	1	09/01/14	B		X	X	B	TO REV. B
050024-2	RESISTOR 100W 2 OHM	1	09/01/14	F		X	X	B	TO REV. F
050026	TIMER	1	09/01/14	C		X	X	B	TO REV. C
050031	BRUSH	1	09/01/14	B		X	X	B	TO REV. B
050032	BRUSH CAP	1	09/01/14	B		X	X	B	TO REV. B
050033	COIL, 24 VDC	1	01/19/22	C		X	X	B	TO REV. C
050034	COIL, 24 VDC	1	09/01/14	B		X	X	B	TO REV. B
050035	BRUSH	1	09/01/14	B		X	X	B	TO REV. B
050038	BRUSH	1	09/01/14	B		X	X	B	TO REV. B
050043	BRUSH	1	09/01/14	B		X	X	B	TO REV. B
050044	CIRCUIT BOARD FRESH AIR	3	09/01/14	B			X	B	TO REV. B
050052	MOTOR 24VDC DBL. SHAFT	1	01/19/22	E		X		B	TO REV. E
050068	12V REGULATOR	1	09/01/14	C		X	X	B	TO REV. C
050084	FAN, VANE AXIAL, 24 VDC, 7"	3	09/01/14	B		X	X	B	TO REV. B
050107	SWITCH, LOW PRESSURE	1	09/01/14	E		X	X	B	TO REV. E
050108	PLUG, 4 PIN	1	09/01/14	B		X	X	B	TO REV. B
050109	4 PIN RECEPTACLE	1	09/01/14	B		X	X	B	TO REV. B
050110	CABLE CLAMP KIT SHELL SIZE = 11	1	09/01/14	D		X	X	B	TO REV. D
050111	PLUG, 9 PIN	1	09/01/14	C		X		B	TO REV. C
050112	RECEPTACLE, 9 PIN	1	09/01/14	C		X		B	TO REV. C
050113	CABLE CLAMP KIT SHELL SIZE = 13	1	09/01/14	B		X		B	TO REV. B
050114	RECEPTACLE IN LINE	1	09/01/14	C		X		B	TO REV. C
050115	PLUG, CANNON	1	09/01/14	C		X	X	B	TO REV. C
050116	RECEPTACLE SINGLE PIN	1	09/01/14	B		X	X	B	TO REV. B
050117	CABLE CLAMP	1	09/01/14	C		X	X	B	TO REV. C
050118	PLUG	1	09/01/14	C		X	X	B	TO REV. C
050119	RECEPTACLE	1	09/01/14	C		X	X	B	TO REV. C
050131	RESET RELAY	1	09/01/14	C		X	X	B	TO REV. C
050132	SERVO	1	09/01/14	D		X	X	B	TO REV. D
050134	CLEVIS ROD ASSY	1	09/01/14	B		X	X	B	TO REV. B
050137	RESET RELAY	1	09/01/14	B		X	X	B	TO REV. B
050144	BRUSH	1	09/01/14	B		X	X	B	TO REV. B
060004	5" DUCT	1	02/04/08	A		X	X	B	TO REV. A
060005	4 GROOVE BELT	1	08/04/23	D		X	X	B	TO REV. D
060006	5 GROOVE BELT	1	09/01/14	B		X	X	B	TO REV. B
060018	FLAT BELT	1	08/04/23	E		X		B	TO REV. E
060018-1	FLAT BELT	1	08/04/23	C		X		B	TO REV. C
060025	2 1/2" DUCT	1	09/01/14	B		X	X	B	TO REV. B
060036	3" BAND CLAMP	1	01/19/22	C		X	X	B	TO REV. C
060037	1" BAND CLAMP	1	08/04/23	C		X	X	B	TO REV. C
070005	DRAIN TUBING	1	09/01/14	B		X	X	B	TO REV. B
070076	ALUMINUM FOIL TAPE	1	09/01/14	B		X	X	B	TO REV. B
070077	.25 HEATSHRINK	1	09/01/14	B		X	X	B	TO REV. B
070077-1	.125 HEATSHRINK	1	09/01/14	B		X	X	B	TO REV. B



DRAWING NUMBER	DRAWING TITLE	# OF PAGES	DRAWING DATE	REVISION	DESCRIPTION	AS 350	EC130B4	SIZE	NEW/RVSD
070077-2	.375 HEATSHRINK	1	09/01/14	B		X	X	B	TO REV. B
070077-3	.50 HEATSHRINK	1	09/01/14	B		X	X	B	TO REV. B
070078	FOAM INSULATION TAPE	1	08/04/23	C		X	X	B	TO REV. C
070078-O	PT-1 CORK INSULATION TAPE	1	09/01/14	A		X	X	B	TO REV. A
070087	LINKAGE	1	09/01/14	B		X	X	B	TO REV. B
080005	SCREEN EM-3	1	08/04/23	D		X	X	B	TO REV. D
080006	1/2 X 1/2 .047 SCREEN	1	09/01/14	B		X	X	B	TO REV. B
080048	SCREEN	1	09/01/14	C		X	X	B	TO REV. C
090002	EXPANSION VALVE	1	09/01/14	B		X		B	TO REV. B
090002-"O"	EXPANSION VALVE	1	09/01/14	C		X	X	B	TO REV. C
090002-2	EXPANSION VALVE	1	09/01/14	B		X		B	TO REV. B
090004	HIGH PRESSURE SWITCH	1	08/04/23	E		X	X	B	TO REV. E
090004-1	HIGH PRESSURE SWITCH	1	09/01/14	B		X	X	B	TO REV. B
090016-2	RECIEVER/DRIER	1	09/01/14	C		X		B	TO REV. C
090016-5	RECIEVER / DRIER	1	08/04/23	E		X	X	B	TO REV. E
090018	DRAIN TUBE 3/8" I.D.	1	09/01/14	C		X	X	B	TO REV. C
090018-1	DRAIN TUBE 1/2" I.D.	1	09/01/14	C		X	X	B	TO REV. C
090089	#6 NYLON BARRIER HOSE	1	08/04/23	C		X	X	B	TO REV. C
090090	#8 NYLON BARRIER HOSE	1	08/04/23	C		X	X	B	TO REV. C
090091	#10 NYLON BARRIER HOSE	1	01/19/22	C		X	X	B	TO REV. C
090092	6# R134A O-RING	1	01/19/22	D		X	X	B	TO REV. D
090093	8# R134A O-RING	1	01/19/22	D		X	X	B	TO REV. D
090094	10# R134A O-RING	1	01/19/22	D		X	X	B	TO REV. D
09-STD-21-101	#10 FITTING STRAIGHT MALE	1	08/04/23	B		X		B	TO REV. B
100100	DRAIN NIPPLE 3/8"	1	09/01/14	B		X	X	B	TO REV. B
100100-1	DRAIN NIPPLE 1/2"	1	09/01/14	C		X	X	B	TO REV. C
100126-"O"	5/8" X #10 X 90 FEMALE O-RING	1	09/01/14	B		X	X	B	TO REV. B
100127-"O"	5/8" X #10 X 45 FEMALE O-RING	1	09/01/14	B		X	X	B	TO REV. B
100128-"O"	5/8" X #10 X STRIGHT FEMALE O-RING	1	08/04/23	C		X	X	B	TO REV. C
100129-"O"	1/2" X #8 X 90 FEMALE O-RING	1	08/04/23	D		X	X	B	TO REV. D
100130-"O"	1/2" X #8 X 45 FEMALE O-RING	1	08/04/23	C		X	X	B	TO REV. C
100131-"O"	1/2" X #8 X STRAIGHT FEMALE O-RING	1	01/19/22	C		X	X	B	TO REV. C
100132-"O"	3/8" X #6 X 90 FEMALE O-RING	1	01/19/22	C		X	X	B	TO REV. C
100133-"O"	3/8" X #6 X 45 FEMALE O-RING	1	09/01/14	B		X	X	B	TO REV. B
100134-"O"	3/8" X #6 STRAIGHT FEMALE O-RING	1	08/04/23	C		X	X	B	TO REV. C
100135	#6 X #6 SPLICE W/R134A SERVICE PORT	1	08/04/23	C		X	X	B	TO REV. C
100136	#10 X #10 X INLINE W/R134A SERVICE PORT	1	09/01/14	B		X	X	B	TO REV. B
100137-"O"	3/8" #6 TEE FITTING	1	09/01/14	D		X	X	B	TO REV. D
100140	5/8" X #10 X 90 FEMALE FLARE	1	09/01/14	B		X		B	TO REV. B
100141	#10 X #10 X #10 TEE SPLICER	1	09/01/14	B		X	X	B	TO REV. B
100143	#6 X #6 X #6 T SPLICER	1	09/01/14	B		X	X	B	TO REV. B
100144	3/8" X #6 SPLICE W.SIGHT GLASS	1	09/01/14	B		X		B	TO REV. B
100147-"O"	1/2 X #6 X STRIAGHT FEMALE O-RING	1	09/01/14	B		X		B	TO REV. B
100148	10 X 10 INLINE W/SCHRADER	1	09/01/14	B		X	X	B	TO REV. B
100149	#6 X #6 SPLICE SCHRADER	1	08/04/23	C		X	X	B	TO REV. C
100162	#10 TEE FITTING	1	01/19/22	D		X		B	TO REV. D
120117	REFRIGERANT LABEL	1	09/01/14	C		X	X	B	TO REV. C
120203	MOTOR AIR FLOW STICKER	1	09/01/14	A		X	X	B	TO REV. A
120204	RSG PRODUCTS INC. ID TAG	1	08/04/23	C		X	X	B	TO REV. C
250371	PROPELLER	1	09/01/14	B		X	X	B	TO REV. B

FLIGHT MANUAL
SUPPLEMENTS
FOR
AS350B, B1, B2, B3, C, D AND D1
ARE
LOCATED
AT:

www.rotorcraftservices.com/customer-support/

Step 12

Continued Airworthiness

ASG

PRODUCTS INC.

Air Conditioning System Installation

Instructions for Continued Airworthiness
for
Airbus Helicopters AS-350 B, C, D, D1, B1, B2, B3, BA &
EC-130 B4

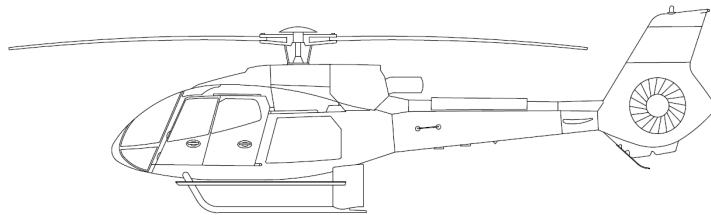
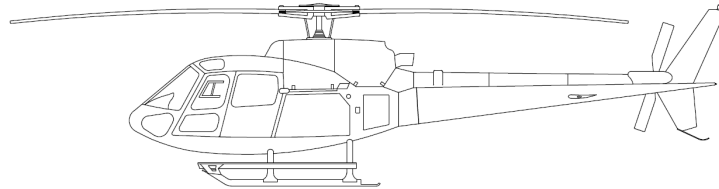

FAA Project Number: SA3109RC-R
STC Number: SH3509SW



DATE:
08/04/2023

DOC No.:
IFSE-0007

REV:
F-1

PAGE:
ii of vii

TITLE:
Air Conditioning System Installation Instructions For Continued Airworthiness for Airbus Helicopters AS-350 B, C, D, D1, B1, B2, B3, BA & EC-130 B4

LOG OF REVISIONS

Instructions for Continued Airworthiness for the Airbus Helicopters AS-350 B, C, D, D1, B, B1, B2, B3, BA and EC-130 B4 Air Conditioning System Installation have been reviewed and found to be acceptable to the Administrator. For the purpose of these Instructions for Continued Airworthiness (ICA), acceptable to the Administrator means the ICA contains the applicable requirements specified in Appendix A to Federal Aviation Regulations Part 27, as appropriate, do not contain any incorrect terminology or incorrect references, and contain a Cover Page, Log of Accepted Revisions, Revision Control Procedure and Record of Temporary Revisions, a list of Effective Pages, and a Table of Contents. Changes to this document will be distributed to owners of the kits within 10 days after the revision is approved. Changes to this document will be indicated by a revision letter in the header, in the Record of Revisions, and on the List of Effective Pages. Contact RSG Products by mail at 440 West Lane Suite 100, Saginaw, TX, 76131. Or by phone at 817-624-6600.

REV	Date	Description	Written By	Checked By	FAA Approval	Approval Date
-	05/03/10	Original Issue	E. Sherrill	P. Ban		
A	06/11/10	Incorporated FAA redlines	E. Sherrill	K. Sheridan		
B	08/08/10	Revised to add Brushless Motor part information, page 87	E. Sherrill	P. Ban		
C	08/12/10	Incorporated FAA redlines	E. Sherrill	P. Ban		
C-1	12/11/13	Revised Chapter 5, 100 hour inspection to change belt on condition. Changed Name.	A. Weidler	S. Weidler		
C-2	09/17/14	Revised Chapter 12 and 21. Removed paragraphs 7 - 9 of Section 12-10-02.d. Removed sight glass troubleshooting information Section 21-00-06 under symptoms.	A. Cuellar	S. Weidler		
C-3	09/30/14	Revised chapter 5 to increase inspection interval to 150 Hours +/- 15	S. Weidler	S. Weidler		
D	11/19/14	Changed Template. Changed Mfr. Name. Was: Eurocopter, Is: Airbus Helicopters. Updated parts list with newer configurations. Parts list is now	S. Johnson	S. Thornton		



DATE:
08/04/2023

DOC No.:
IFSE-0007

REV:
F-1

PAGE:
iii of vii

TITLE:
Air Conditioning System Installation Instructions For Continued
Airworthiness for Airbus Helicopters AS-350 B, C, D, D1, B1, B2, B3, BA &
EC-130 B4

		under Chapter 31. Updated electrical and plumbing diagrams and install drawings. Updated annual/150-hour inspection program in sections 05-00-00 and 05-10-00.				
E	01/12/17	Remove 50 hour inspection table and added Component Overhaul/Replacement schedule for blower motors. Remove, add and update images for Sections 11-00-00, 21-00-00, & 21-10-00	A. Cuellar	S. Weidler		
F	01/19/22	Update to include changes made for MDL Rev U. Change amount of refrigerant to paragraph 1 and 5 on page 18 of 99. Added acceptance criteria to table 5-01 item 8	S. Brewer	K. Musgraves		
F-1	08/04/23	Change time delay of "4 to 8 seconds" to "15 seconds" on page 28 of 99. Updated Weight and Balance information on pages 97, 98 and 99 of 99. Update also includes changes made for MDL Rev V.	S. Brewer	K. Musgraves		

Typed signatures indicate approval. Handwritten signature approvals of this document are on file at RSG Products Inc.



DATE:
08/04/2023

DOC No.:
IFSE-0007

REV:
F-1

PAGE:
v of vii

TITLE:
Air Conditioning System Installation Instructions For Continued
Airworthiness for Airbus Helicopters AS-350 B, C, D, D1, B1, B2, B3, BA &
EC-130 B4

LIST OF EFFECTIVE PAGES

LIST OF REVISIONS	Revision A	December 06, 2012
	Revision B	February 27, 2013
	Revision C	May 14, 2013
	Revision D	November 19, 2014
	Revision E	January 12, 2017
	Revision F	January 19, 2022

LIST OF EFFECTIVE PAGES

<u>TITLE</u>	<u>PAGES</u>	<u>REV.No</u>
Cover	i	D
Log of Revisions	ii	D
Record of Temporary Revisions	iv	D
List of Effective Pages	v	D
Table of Contents	vi - vii	D
Chapter 1 Introduction	1	D
Chapter 4 Airworthiness Limitation	2	D
Chapter 5 Continued Airworthiness Inspections and Overhaul	3 - 9	E1
Chapter 6 Dimensions and Access	10 - 12	D
Chapter 11 Markings and Placards	13	E
Chapter 12 Servicing Maintenance Practices	14 - 30	D
Chapter 20 Standard Practices	31 - 43	E1
Chapter 21 Air Conditioning	44 - 59	E
Chapter 31 Illustrated Parts List	60 - 83	D
Chapter 98 Wiring Diagrams and Plumbing Schematics	84 - 96	D
Appendix A Weight and Balance	97 - 99	D



DATE:
08/04/2023

DOC No.:
IFSE-0007

REV:
F-1

PAGE:
vi of vii

TITLE:
Air Conditioning System Installation Instructions For Continued
Airworthiness for Airbus Helicopters AS-350 B, C, D, D1, B1, B2, B3, BA &
EC-130 B4

Table of Contents

LOG OF REVISIONS.....	ii
RECORD OF TEMPORARY REVISIONS.....	iv
LIST OF EFFECTIVE PAGES.....	v
Chapter 1	1
Section 01-00-00 Introduction	1
Chapter 4	2
Section 04-00-00 Airworthiness Limitations	2
Chapter 5	3
Section 05-00-00 Continued Airworthiness Inspection	3
Section 05-10-00 Continued Airworthiness Scheduled Inspection	6
Chapter 6	10
Section 06-00-00 Dimensions and Access.....	10
Chapter 11	13
Section 11-00-00 Placards and Markings.....	13
Chapter 12	14
Section 12-00-00 Servicing Maintenance Practices.....	14
Section 12-10-00 Charging Practices.....	15
Section 12-20-00 Clutch Servicing Practices	20
Section 12-30-00 System Leak Check.....	26
Section 12-40-00 Fitting Torque Procedures	27
Section 12-50-00 Normal Operation Functional Test.....	28
Section 12-60-00 Belt Tension Procedure.....	29
Section 12-70-00 Drive Belt Change Procedure	30
Chapter 20	31
Section 20-00-00 Standard Practices.....	31
Section 20-10-00 Torques Maintenance Practices	32
Section 20-30-00 Painting Maintenance Practices.....	37



DATE:
08/04/2023

DOC No.:
IFSE-0007

REV:
F-1

PAGE:
vii of vii

TITLE:
Air Conditioning System Installation Instructions For Continued
Airworthiness for Airbus Helicopters AS-350 B, C, D, D1, B1, B2, B3, BA &
EC-130 B4

Section 20-40-00 Corrosion Control Maintenance Practices.....	38
Section 20-50-00 Mechanical Fastener Sealing Methods.....	42
Section 20-90-00 Dye-Penetrant Inspection Methods	43
Chapter 21	44
Section 21-00-00 Air Conditioning.....	44
Section 21-10-00 Illustrated Parts List	60
Chapter 98	84
Section 98-00-00 Wiring Diagrams and Plumbing Schematics	84
APPENDIX A Weight and Balance.....	96



DATE:
08/04/2023

DOC No.:
IFSE-0007

REV:
F-1

PAGE:
1 of 99

TITLE:
Air Conditioning System Installation Instructions For Continued Airworthiness for Airbus Helicopters AS-350 B, C, D, D1, B1, B2, B3, BA & EC-130 B4

Chapter 1

Section 01-00-00 Introduction

These are accepted Instructions for Continued Airworthiness for modifications performed in accordance with the Airbus Helicopters AS-350 B, C, D, D1, B, B1, B3, BA and EC-130 B4 Belt-Driven Vapor Cycle Air Conditioning System Installation. All references to the Air Conditioning System in this document will refer to the Belt-Driven Air Conditioning System Installation and other related components specified in STC – SH3509SW. Whether modified by Rotorcraft Services Group or by another Agency with expressed permission from RSG these Instructions for Continued Airworthiness (ICA) should be supplied to the owner/operator of the STC at the time of completion. Subsequent accepted changes to the ICA will be submitted by Rotorcraft Services Group for distribution to owners and operators of the STC.

This, Instructions for Continued Airworthiness, is intended to supplement the AS-350 B, C, D, D1, B, B1, B2, B3, BA, and EC-130 B4 rotorcraft maintenance manuals provided by Airbus Helicopters. The information, procedures, requirements, and limitations contained in this, Instructions for Continued Airworthiness, for this type design change supersede the information, procedures, requirements, and limitations contained in the rotorcraft's maintenance manual when the type design change is installed on the Type Certificate Holder's rotorcraft.



DATE:
08/04/2023

DOC No.:
IFSE-0007

REV:
F-1

PAGE:
2 of 99

TITLE:
Air Conditioning System Installation Instructions For Continued
Airworthiness for Airbus Helicopters AS-350 B, C, D, D1, B1, B2, B3, BA &
EC-130 B4

Chapter 4

Section 04-00-00 Airworthiness Limitations

“The Airworthiness Limitations section is FAA approved and specifies inspections and other maintenance required under §§43.16 and 91.403 of the Federal Aviation Regulation unless an alternative program has been FAA approved.”

There are no additional airworthiness limitations associated with the Air Conditioning System Installation.

There are no life limited components associated with the Air Conditioning System Installation.

Chapter 5

Section 05-00-00 Continued Airworthiness Inspection and Overhaul

1. General

This chapter contains time limit intervals for the Component Overhaul Schedule and Scheduled Inspection for the Air Conditioning System. This chapter is to be added to the approved scheduled inspection for the rotorcraft.

2. Component Overhaul Schedule & Scheduled Maintenance Practices

This chapter describes the inspection that must be accomplished on the Air Conditioning System Installation at Scheduled Inspection intervals. Scheduled Inspection requirements must be complied with at the hourly and/or calendar time intervals specified. Refer to Tables 5-01 and 5-02, in Section 05-10-00 for hourly and/or calendar inspection schedules.

3. Conditional Inspection

After any operational incident involving hard landings, sudden stoppage of the drive train or water immersions the system must not be operated and an Annual or 150 flight hour inspection is required.

4. Documentation

Aircraft mechanics, owners, or operators are required to keep records of the aircraft systems inspections and repairs. This includes, but is not limited to, airworthiness directives, service notices, scheduled inspections, records and life limited components.

5. Definitions

The following is short descriptions of words and terms used in the procedures for the required scheduled inspections.

- **Ambient air temperature:** The temperature of the air surrounding a person.
- **Charging station:** An air conditioning system service.
- **Cold:** The absence of heat.
- **Condensation:** The process of changing a vapor into a liquid.
- **Condition:** The state of an item or component compared to a known standard.



DATE:
08/04/2023

DOC No.:
IFSE-0007

REV:
F-1

PAGE:
4 of 99

TITLE:
Air Conditioning System Installation Instructions For Continued
Airworthiness for Airbus Helicopters AS-350 B, C, D, D1, B1, B2, B3, BA &
EC-130 B4

- **Damage:** Physical deterioration of a component.
- **Desiccant:** A material used in the receiver/dryer bottle, to absorb moisture from the refrigerant.
- **Evaporate:** To change from a liquid into a vapor.
- **Examine:** Look carefully to find the condition of the component. Find how that condition is related to a specific standard.
- **Heat load:** The amount of heat which the air conditioner is required to remove from the aircraft cabin.
- **Inches of Mercury:** A measurement of pressure normally used for pressures below atmospheric, one i-h of mercury is equal to approximately one-half pound per square i-h.
- **Inspection:** A procedure that includes checking, inspecting and examining a system or component.
- **Maintenance:** The servicing and/or repair of a rotorcraft, a system or a component that keeps it serviceable.
- **Pressure, ambient:** The pressure of the air surrounding a body, normally measured in Pounds per Square i-h, or PSIG.
- **Refrigerant:** A fluid which is used in an air conditioning system to absorb heat from the cabin and carry it outside the helicopter where it can be transferred to the outside air.
- **Relative Humidity:** The ratio of the amount of water vapor in the air to the amount of water vapor required to saturate the air at the existing temperature.
- **Scheduled Inspection:** An inspection procedure that must occur at a specified calendar interval or at specific operational time intervals. Scheduled Inspections are required to help ensure the rotorcraft stays airworthy.
- **Security:** Term used for inspection of hardware and components to make sure they are properly attached and tightened.
- **Temperature Differential:** Difference in temperature.
- **Thermostat:** An air condition control which senses the temperature of the evaporator coil and causes the system to cycle or by-pass to maintain the proper temperature of cooling air.
- **Vacuum:** A negative pressure, or pressure below atmospheric; it is usually expressed in inches of mercury.
- **Vapor:** The gaseous state of a material.



DATE:
08/04/2023

DOC No.:
IFSE-0007

REV:
F-1

PAGE:
5 of 99

TITLE:
Air Conditioning System Installation Instructions For Continued
Airworthiness for Airbus Helicopters AS-350 B, C, D, D1, B1, B2, B3, BA &
EC-130 B4

6. Abbreviations:

- **ICA:** Instructions for Continued Airworthiness
- **TD:** Temperature differential
- **In:** Inches
- **InHg:** Inches of Mercury
- **lbs:** Pounds
- **oz:** Ounces
- **Psig:** Pounds per Square I-h (gauge)
- **gr:** Grams
- **kg:** Kilograms
- **kgcm:** Kilograms Per Centimeter
- **ml:** Milliliters
- **mm:** Millimeters
- **N-m:** Newton-meters

Section 05-10-00 Continued Airworthiness Scheduled Inspection

1. General

This section contains requirements for scheduled inspection.

2. Scheduled Inspection Program

The Air Conditioning System Installation requires one scheduled inspection in order to maintain continued airworthiness. Every effort should be made to perform the inspection with the aircraft placed in a clean well-lit environment.

a) Annual or 150-Hour Inspection

The inspection is required to be performed annually or every 150 hours of rotorcraft time-in-service, whichever comes first, + 15 hours not to exceed 165 hours. If inspection is overflowed beyond 165 hours then overflowed time must be deducted from the next inspection due. Inspection Table 5-01 specifies the requirements of the annual inspection.

b) Component Overhaul/Replacement Schedule

The blower manufacturer recommends TBO at 1000 hours.

A blower failure will result in a reduction in cooling, but no safety-of-flight issues are involved. Component Overhaul/Replacement Schedule Table 5-02 specifies the requirements of overhaul/replacement hours.

3. Tools and Special Tools for Scheduled Inspection

Although not necessarily considered special tools, the adjustable ball swivel mirror and bright flashlight and / or drop light are standard requirements for doing inspections. These items should be used freely and frequently to enhance inspection quality and help ensure discrepancies are not missed. It is important to have adequate lighting for all phases of the inspection.

The special tools necessary for the Air Conditioning System Installation inspection are listed as follows:

- a) Vacuum Pump
- b) Gauge Manifold
- c) Vacuum Cleaner
- d) Pull Scale



DATE:
08/04/2023

DOC No.:
IFSE-0007

REV:
F-1

PAGE:
7 of 99

TITLE:
Air Conditioning System Installation Instructions For Continued
Airworthiness for Airbus Helicopters AS-350 B, C, D, D1, B1, B2, B3, BA &
EC-130 B4

Table 5-01 Annual or 150 – Hour Inspection

Registration No.	Serial No.	Helicopter Total Hours
<ul style="list-style-type: none"> The inspection shall be accomplished annually or every 150 hours of rotorcraft time-in-service, whichever comes first, + 15 hours not to exceed 165 hours. If inspection is overflowed beyond 165 hours then overflowed time must be deducted from the next inspection due. Initial each item after accomplishing the inspection. Record all findings and attach a copy of findings to this inspection form. After correction of all findings, make maintenance record entry. 		
PRE-INSPECTION		Initial
1. Review Airworthiness Directives.		
2. Review records for the Air Conditioning System.		
3. Review log books for discrepancies.		
INSPECTION		Initial
1. Perform an operational test of the system in accordance with Section 12-50-00		
2. Inspect the condition of the belt for cracks, deterioration, separation and worn or flat spots. Change belt if necessary. Check belt for proper tension (Ref. 12-60-00 Belt Tension).		
3. Inspect the compressor for a true turning and free clutch. One mechanic should turn the main rotor blade while another observes the belt and clutch faceplate. Turn system to "A/C" and check magnetic operation of clutch faceplate. Inspect compressor ground wire for condition and conductivity. If clutch plate and pulley show signs of excessive heat, replace clutch pulley assembly, bearing and coil (Ref. Section 12-20-00 Clutch Servicing Procedures)		
4. Inspect the compressor clutch bearing. It is not mandatory to grease the bearing. If the bearing is greased use a hypodermic needle, without removing the bearing using 3 to 5cc of Mobil 28 grease. This has proven to be satisfactory when performed at regularly scheduled inspections of 500 hours. Some operators flying as much as 200 hours per month have found that re-greasing can occur at more than 500-hour intervals, provided they DO NOT OVER PACK THE BEARING. 100% capacity packing of the bearing can cause a failure to occur in 1 to 1 ½ hours.		
5. Inspect hoses for general condition, cuts or swelling. Replace as required.		
6. Check for security of all plumbing fittings (Ref. Section 12-40-00 Fitting Torque Procedures). Replace fittings as needed. Check security of clamps and anti-chaff material. Perform system leak check (Ref. 12-30-00 System leak check).		



DATE:
08/04/2023

DOC No.:
IFSE-0007

REV:
F-1

PAGE:
8 of 99

TITLE:
Air Conditioning System Installation Instructions For Continued
Airworthiness for Airbus Helicopters AS-350 B, C, D, D1, B1, B2, B3, BA &
EC-130 B4

7. For brushed motors only, access the Aft Evaporator (Ref. Section 6-00-00 Dimensions and Access). Aft evaporator motor has two (2) removable brushes. Detach elbow from top of blower assembly. Remove brushes one (1) at a time. Note position relative to curvature of armature. Inspect brush for wear. Replace if brush is 5/16" or less. Install new brushes and run at 12 VDC (utilizing an independent power source).

Until seating occurs on 70% of the surface (this should be accomplished with motor assembly removed from aircraft). This action will greatly enhance brush life. Reconnect wires to aircraft system and reinstall insulated duct. Run both of the blower/fans in the "FAN" position and perform visual inspection of the assemblies to see that foreign materials have not been ingested into the blower/fan, which might cause blade damage. The blower/fan should also be run at the various speeds available to check the motor operation.

8. Access the condenser (Ref. Section 6-00-00 Dimensions and Access). Check the fins of the condenser coil for cleanliness and ensure that they are straight. If damage has occurred to the fins, a fin comb should be utilized to put them in like new condition. If damaged fins that cannot be straighten account for $\leq 3\%$ of the overall fin-covered surface area of the condenser, the operation of the condenser will remain unaffected.



DATE:
08/04/2023

DOC No.:
IFSE-0007

REV:
F-1

PAGE:
9 of 99

TITLE:
Air Conditioning System Installation Instructions For Continued
Airworthiness for Airbus Helicopters AS-350 B, C, D, D1, B1, B2, B3, BA &
EC-130 B4

Table 5-02 Component Overhaul/ Replacement Schedule

Description	Part Number	Overhaul/Replacement Hours
Aft Evaporator Blower Motor	490017-1-01 (IFSS 050143-3 DCB) 490017-1-02 (IFSS 050143-2 DCB)	The blower manufacturer recommends TBO at 1000 hrs. At the discretion of the operator, it is acceptable to operate the blower until failure. A blower failure will result in a reduction in cooling, but no safety-of-flight issues are involved.
Condenser Blower Motors	IFSS 050143-3 DCB or IFSS 050084-7-2 & IFSS 050084-7-3	Same as above

Chapter 6

Section 06-00-00 Dimensions and Access

1. Access Methods

a) Access Item Identification (Ref. figures 6-01 & 6-02)

- **Condenser-** The condenser is located in one of two positions depending on kit part number (Ref. Section 21.00.00 System Description). The aft mounted condenser (Kit numbers 350-00-031HP and 130-00-031HP) (Ref. figure 6-02) is mounted in the tail boom mounted 5 in. above the baggage floor and is accessed by removing the tail boom closeout panel. The side mounted condenser (Kit Number 350-00-011HP) is located in the right baggage compartment (Ref. figure 6-01) and is accessed by removing to baggage compartment close out panel.
- **Compressor-** The compressor is located aft and to the left side on main transmission deck. It is accessed by opening the upper transmission cowling.
- **Aft Evaporator-** The aft evaporator is located on the right-hand upper transmission deck in all configurations. It is accessed by opening the right-hand transmission cowling forward latch.
- **Forward Evaporator-** In the AS-350 series, the forward evaporator is located on the cockpit floor forward of the pilots' controls. In the EC-130, it is located on the cockpit floor forward of the pedestal and mounted to the pedestal. No additional access method is required.

b) Removal and Installation Methods

Caution: Use of power tools during removal or installation of panels and attaching hardware may damage nut plates or deform holes in composite doors, covers, panels, and fairings.

TITLE:
Air Conditioning System Installation Instructions For Continued
Airworthiness for Airbus Helicopters AS-350 B, C, D, D1, B1, B2, B3, BA &
EC-130 B4

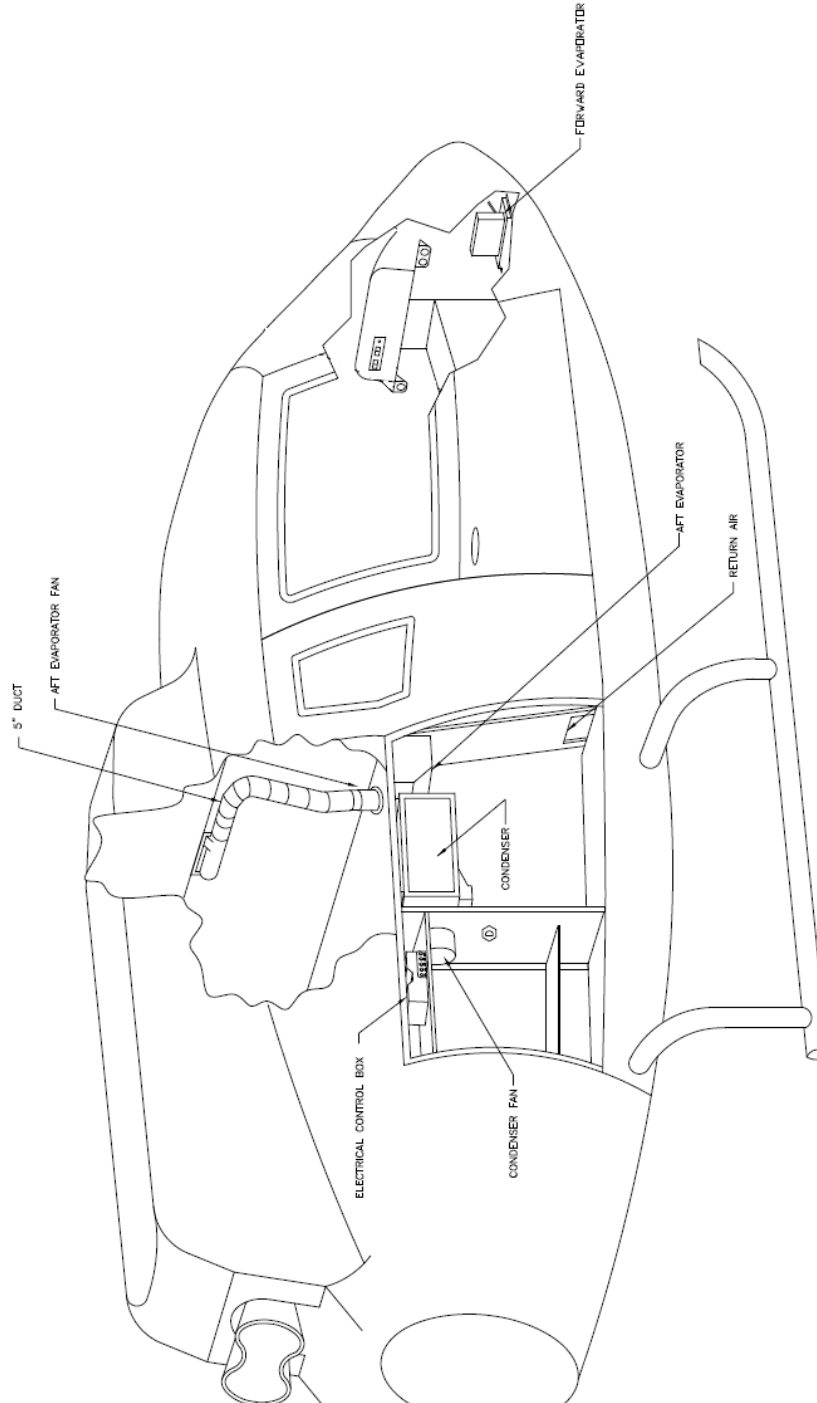

Figure 6-01: Side Mounted Condenser Configuration

TITLE:
Air Conditioning System Installation Instructions For Continued
Airworthiness for Airbus Helicopters AS-350 B, C, D, D1, B1, B2, B3, BA &
EC-130 B4

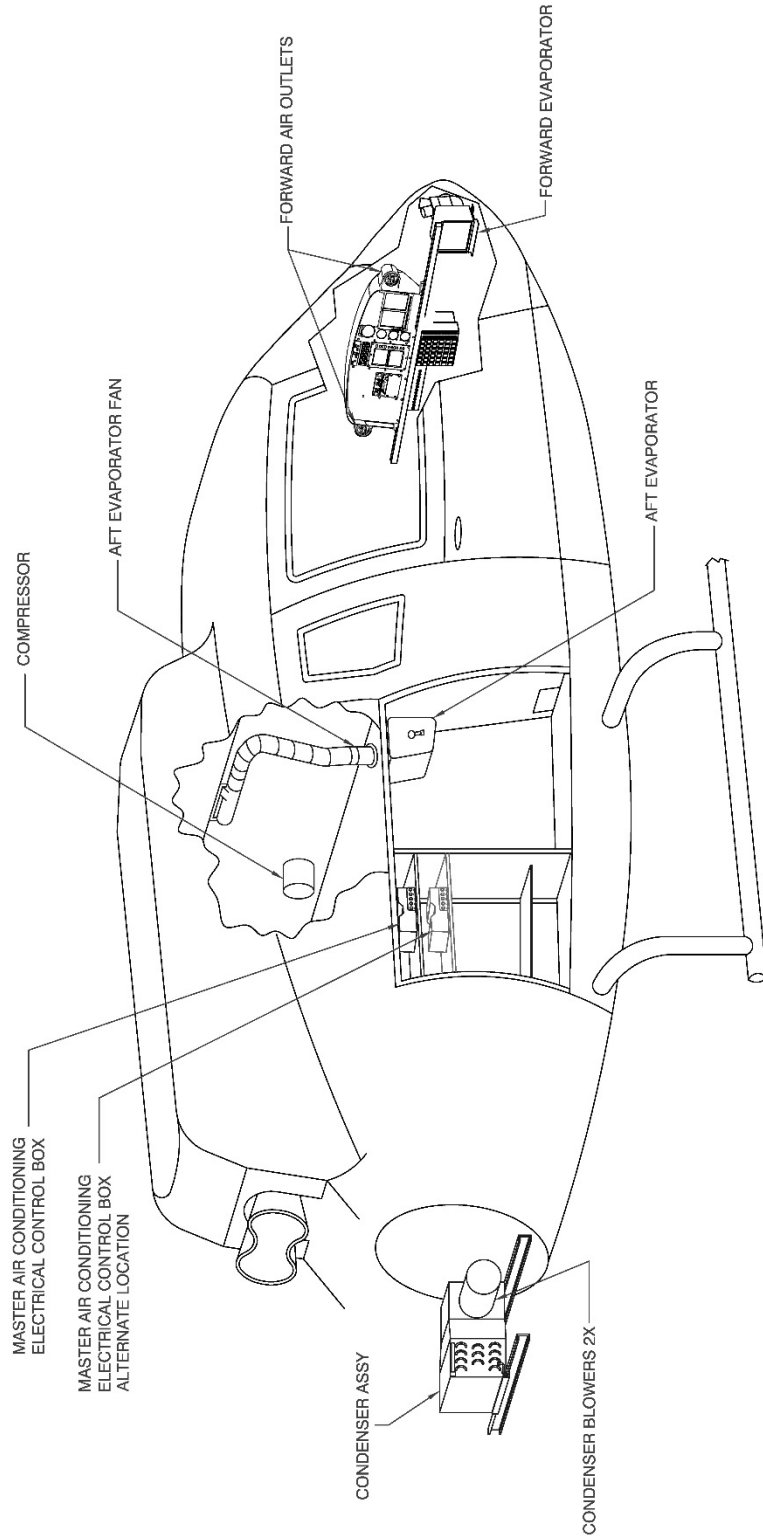
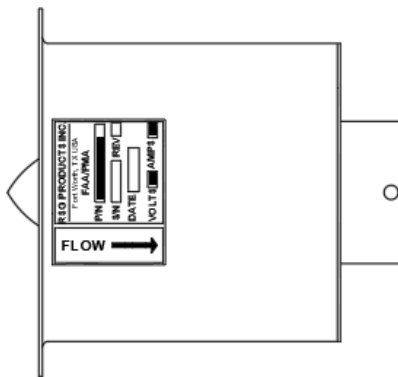

Figure 6-02: Aft Mounted Condenser Configuration

Chapter 11

Section 11-00-00 Placards and Markings

1. Placards and Decals



For PN: IFSS 050143



For PN: 550007-1

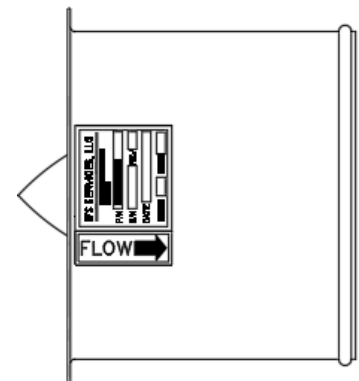

For PN: IFSS 050084

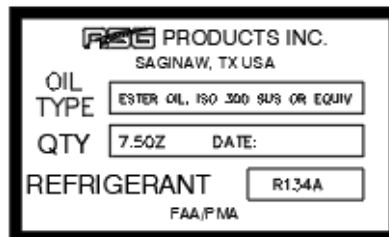

For PN: 590008 & 590008-1

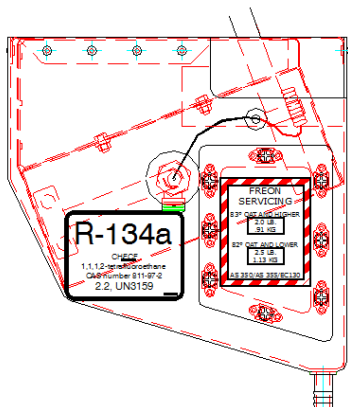

For PN: 560010-O-5 & 560016-O-1



For PN: 050145



DATE:
08/04/2023

DOC No.:
IFSE-0007

REV:
F-1

PAGE:
14 of 99

TITLE:
Air Conditioning System Installation Instructions For Continued
Airworthiness for Airbus Helicopters AS-350 B, C, D, D1, B1, B2, B3, BA &
EC-130 B4

Chapter 12

Section 12-00-00 Servicing Maintenance Practices

1. General

It is assumed in the following practices that the personnel engaged in Charging, Servicing, or Maintenance of the system will be either an experienced air conditioning mechanic under the supervision of a qualified A & P mechanic or an A & P mechanic possessing good air conditioning skills.

Section 12-10-00 Charging Practices

1. Reclaiming

- a) Connect the EPA approved recovery unit services hoses, which shall have shut-off valves to the aircraft air conditioning system service ports.
- b) Operate the recovery equipment as covered by the equipment manufacturers recommended procedure.
- c) Start the recovery process and remove the refrigerant from the aircraft air conditioning system. Operate the recovery unit until the aircraft system has been reduced from a pressure to a vacuum. With the recovery unit shut off for at least 5 minutes, determine that there is not refrigerant remaining in the aircraft air conditioning system. If the aircraft system has pressure, additional recover operation is required to remove the remaining refrigerant. Repeat the operation until the aircraft air conditioning system vacuum level remains stable for two minutes.
- d) Close the valves in the service lines and then remove the service lines from the aircraft system. Proceed with the repair/service. If the recovery equipment has automatic closing valves, be sure they are properly operating.

2. Charging

a) **Prior to Charging the System**

Prior to charging the system with R-134a, the evaporator fan/blower and condenser blower should be checked for operation and direction of airflow. This is most easily done by utilizing a GPU unit for electrical power. Since the compressor is belt driven only those maintenance and operational functions that are electrically powered may be checked either in the hanger or on the ramp without running the engine.

After the GPU is connected to the aircraft and the Aircraft Master Switch is "On", the air conditioning system may be turned "On". Place the rocker switch on the Master Air Conditioning Control Panel to "A/C". It does not cause the compressor to run or refrigerant to be pumped. All evaporator blowers and the forward evaporator fan should start immediately. The 7" condenser blower and clutch will not engage until after approximately 4 seconds after evaporator fan start.

NOTE: SYSTEM MUST HAVE MINIMUM 30 PSI CHARGE

Check airflow of each evaporator fan/blower. Determine that air is coming out of the cockpit and the cabin air outlets.



DATE:
08/04/2023

DOC No.:
IFSE-0007

REV:
F-1

PAGE:
16 of 99

TITLE:
Air Conditioning System Installation Instructions For Continued
Airworthiness for Airbus Helicopters AS-350 B, C, D, D1, B1, B2, B3, BA &
EC-130 B4

Check airflow into and out of condenser air openings.

b) **Charging the System**

*NOTE: All evaporators' fan/blower, condenser blowers, and controls are 28-volt DC.

DANGER: R-134a, particularly liquid R-134a, should never be allowed to come in contact with the eyes or skin. Under normal conditions, R-134a as a gas or vapor is an inert substance and non-poisonous. A flame-type leak detector should never be used because of the danger of fire or explosion around an aircraft. Several electronic leak detectors are available on the market.

Never heat a cylinder of R-134a to produce additional pressure or to squeeze that last bit of refrigerant from the cylinder. If the cylinder has become cooled to the point where additional refrigerant cannot be obtained from it, the only approved method is to place the entire cylinder in a container of warm water. **Do Not Exceed 120 Degrees Fahrenheit.**

Never attempt to repair a leak requiring brazing or soldering within the aircraft structure as fire or explosion can result. Remove the entire assembly from the aircraft to a safe location before attempting such a procedure.

CAUTION: Should R-134a come in contact with the eyes or skin, Do Not attempt first aid beyond the immediate washing of the eye or skin with clear water. A doctor should be contacted immediately for diagnosis and treatment even though the injury may be considered slight.

The refrigerant used in this system R-134a, and no other refrigerant is to be considered. Normal safety practices, such as wearing of gloves and the use of goggles, should be utilized as R-134a could freeze the eyeball instantly were it to come in contact with the eye. Also, frostbite could occur to areas of the skin if R-134a were allowed to come in contact.

Charging of the system is a simple procedure whether on initial or recharging after leakage repair. A set of refrigerant gauges with a minimum of three hoses should be connected to the high side and low side service ports provided.

Prior to charging each newly installed system with R-134a, **you will not need to charge compressor with oil since 7.5 ounces of ESTER oil has already been**

added. Do not add additional oil if replacing a compressor in an existing system.

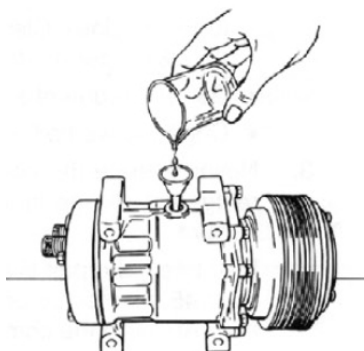

Figure 12 - 01: Adding Oil to the Compressor

c) **Initial Charging**

Tighten any leaking connections or make repairs as necessary to eliminate leaks. Shut off and disconnect hose from the refrigerant cylinder. Connect the hose to a regulator mounted on a cylinder of dry nitrogen. Purge the regulator to center manifold hose. **Close low side valve (left) at manifold. Failure to do so can cause pressure to flow to the low side (left) gauge. Failure of gauge can result.**

Pressurize system to 250-PSI minimum, 300-PSI maximum.

After the system has been rechecked with the leak detector and it is determined that no leaks exist, disconnect the charging hose from the manifold set to the cylinder of nitrogen. Open the valves allowing the R-134a and nitrogen within the system to be collected into an EPA approved recycling until (expelling of refrigerant is not allowed).

Connect a vacuum pump to the center manifold hose. Open both valves and evacuate the system for a minimum of twenty minutes. **(NOTE: For each 1,000 foot rise in altitude above sea level, a decrease below 30" of vacuum of 1" per one thousand feet rise in altitude will occur).**

d) **Adding R134-a Refrigerant**

Close both the manifold valves and connect the center charging hoses to a cylinder of R-134a. Open the valves of the cylinder. Purge the charging hose by loosening it at the charging manifold's center hose. **ONLY THE HIGH SIDE VALVE OF THE CHARGING MANIFOLD MAY NOW BE OPENED**



DATE:
08/04/2023

DOC No.:
IFSE-0007

REV:
F-1

PAGE:
18 of 99

TITLE:
Air Conditioning System Installation Instructions For Continued
Airworthiness for Airbus Helicopters AS-350 B, C, D, D1, B1, B2, B3, BA &
EC-130 B4

The combination of the vacuum still existing and the pressure in the R-134a cylinder transfers the R-134a from the cylinder into the system, **on the high side only**, without the compressor running. If a scale is available, the cylinder may be pre-weighted and **2.5 pounds of refrigerant R-134a added to the system**. No additional refrigerant should be added after the system is in operation. Close manifold.

The system is now ready for operation. **This must be performed on the flight line with the engine at 100%**. As soon as the "A/C" Master Control Switch is turned to "A/C" all 28 VDC evaporator fans will immediately begin operations.

If, after the system has been in the "A/C" mode for at least 2 minutes and cooling is not being accomplished, then check all circuit breakers.

Determine that 28 VDC power is available for control circuitry. Check operations of the relays and contacts

After the compressor has come on line, the entire system is operational with the manifold valve closed on the high side. The R-134a cylinder valve should be closed initially in order to get an accurate reading on the low side gauge of the "system pressure". The reading on the gauge should not be allowed to go below 10 PSI, as this will indicate that the low-pressure safety switch is possibly set too low. It will disconnect the electrical power to the compressor clutch if allowed to open. Open or close the cylinder valve as required to monitor the flow of R-134a from the cylinder into the low side of the system, if additional R-134a is needed. **Smoke test is no longer required for R-134a receiver/drier (without sight glass) like it was for R-12 receiver/drier (with sight glass).**

Charge system to 2.5 lbs. The optimum method of determining the correct charge using at least two digital thermometers and place them near the return air and the discharge air of each evaporator. R-134a can then be added or deleted, as required, until the highest T.D. is noted, per the paragraph below. At that time, the correct amount of refrigerant is installed.

A test sheet should be completed noting the average cabin temperature, the temperature on the return or entering air to all evaporators and the discharge air from the evaporators, at the nearest point. If a Temperature Differential (T.D.) of less than 20 degrees Fahrenheit with a humidity of 30% or less is recorded through the evaporators at sea level, the system should be considered as having possible defects, which will need investigation. At altitudes above sea level, less than 20 degrees Fahrenheit temperature difference may be recorded at humidity of 30% or less. This is due to less dense air moving more rapidly through the evaporators.

e) **Effect of Humidity on TD**

It should be noted that in measurements taken and entered on a test sheet that similar measurements made at a later date, when the humidity is considerably higher, would dramatically change the T.D.

The higher the humidity, as compared to a previous T.D. reading taken with a low humidity, will result in a lower T.D. The reason for this lower T.D. measurement is that when a test is performed at lower humidity, only "SENSIBLE HEAT" is being removed. With higher humidity, a different condition exists. It requires that "LATENT HEAT" containing moisture borne heat must first be removed prior to the removal of the sensible heat

If the system is found to be completely empty of R-134a, a set of charging gauges should be connected to both high and low side service ports and to a cylinder of R-134a. Purge the charging hoses from the cylinder to the service ports with R-134a vapor. Open both the low and high side charging valves and allow pressure from the cylinder to equalize through the system until at least 50 PSI is noted. Utilizing an electronic leak detector, check all fittings on the system to determine the point of leakage. Any fitting indicating an oily or dirty condition is a prime suspect.

f) **Recharging the System**

After the leaks have been found and corrected, pressurize the system with dry nitrogen. Re-check for leaks. Connect a vacuum pump to the system and evacuate the system for a minimum of 20 minutes from both the high and low sides. If the system has been allowed to become contaminated, then the receiver/drier is to be replaced.

It is always good air conditioning practice to replace the receiver/drier whenever it is suspected that moisture has contaminated the system.

The balance of the recharging procedure is exactly the same as pointed out previously under the **Charging Operation**. A judgment must be made as to the amount of oil, if any, lost at the point of leakage. Additional oil may be required to be added to the system. If the refrigerant has been expelled rapidly by the rupture of a line or similar situation, then two (2) ounces of refrigerant oil of the type previously specified should be applied to the system at this time and immediately prior to charging of the system with R-134a.

Section 12-20-00 Clutch Servicing Practices

1. General

These clutch servicing practices are applicable to all compressors that can be installed with the Air Conditioning System Installation.

a) Clutch Armature Assembly Removal

- (1) If armature dust cover is present, remove the 3 or 6 bolts holding it in place and remove cover. If auxiliary sheet metal pulley is present, remove the screws holding it in place. Then remove pulley.
- (2) Insert pins of armature plate spanner into threaded holes of armature assembly.
- (3) Hold armature assembly stationary while removing retaining nut with 3/4 in, 19 mm or 14 mm socket wrench as appropriate. (Ref. Figure 12-02)

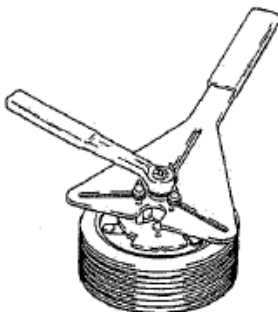

Figure 12 - 02

- (4) Remove armature assembly using puller. Thread 3 puller bolts into the threaded holes in the armature assembly. Turn center screw clockwise until armature assembly comes loose. (Ref. Figure 12-03)

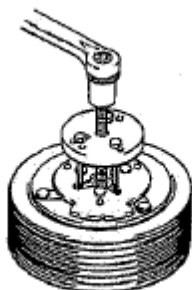

Figure 12 - 03

- (5) If shims are above shaft key, the key and bearing dust cover (if present) must be removed before the shims can be removed.
- (6) Remove bearing dust cover (if present). Use caution to prevent distorting cover when removing it.
- (7) Remove shaft key by tapping loose with a flat blade screwdriver and hammer.
- (8) Remove shims. Use a pointed tool and a small screwdriver to prevent the shims from binding on the shaft.

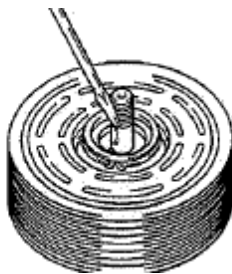

Figure 12 - 04

b) Rotor Assembly Removal

- (1) If bearing dust cover has not been removed, remove it now.
- (2) If internal snap ring for bearing is visible above the bearing, remove it with internal snap ring pliers.
- (3) Remove rotor snap ring.
- (4) Remove shaft key.
- (5) Remove rotor assembly: insert the lip of the jaws into the snap ring groove, place rotor puller shaft protector (puller set) over the exposed shaft, align thumb screws to puller jaws and finger tighten and turn puller center bolt clockwise using a socket wrench until rotor pulley is free. (Ref. Figure 12-05)

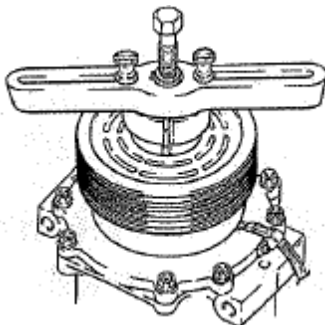

Figure 12 - 05

c) **Field Coil Assembly Removal**

- (1) Loosen lead wire clamp screw with #2 Phillips screwdriver until wire(s) can be slipped out from under clamp.
- (2) Undo any wire connections on the compressor which would prevent removal of the field coil assembly.
- (3) Remove snap ring.
- (4) Remove the field coil assembly. (Ref. Figure 12-06)

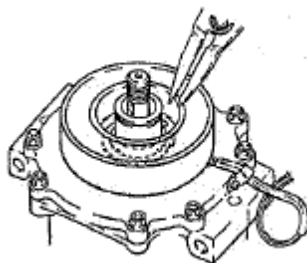

Figure 12 - 06

d) **Field Coil Assembly Installation**

- (1) Reverse the steps of the field coil assembly removal. Protrusion on underside of coil ring must match hole in front housing to prevent movement and correctly locate lead wire(s).

e) **Rotor Assembly Installation**

- (1) Place compressor on support stand, supported at rear end of compressor. If the compressor must be clamped in a vice, clamp only on the mounting ears, never on the body of the compressor.
- (2) Set rotor squarely over the front housing boss.
- (3) Place the rotor installer ring into the bearing bore. Ensure that the edge rests only on the inner race of the bearing, not on the seal, pulley, or outer race of the bearing.
- (4) Place the driver into the ring and drive the rotor down onto the front housing with a hammer or arbor press. Drive the rotor against the front housing step. A distinct change of sound can be heard when using a hammer to install the rotor. (Ref. figure 12-07).



Figure 12 - 07

- (5) Reinstall rotor bearing snap ring, if it has been removed, with internal snap ring pliers. (Ref. figure 12-08)



Figure 12 - 08

- (6) Reinstall rotor retaining snap ring with external snap ring pliers. If a bevel is present in the snap ring, it should be face up (away from the body of the compressor).
- (7) Reinstall rotor bearing dust cover (if present) by gently tapping it into place.

f) **Armature Assembly Installation**

- (1) Install shaft key with pliers. (Ref. figure 12-09)

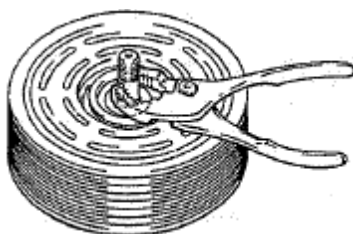

Figure 12 - 09

- (2) Install clutch shims. NOTE: Clutch air gap is determined by shim thickness. When installing a clutch on a used compressor, try the original shims first. When installing a clutch on a compressor that has not had a clutch installed before, first try 0.04 in, 0.02 in and 0.004 in (1.0, 0.5, 0.1 mm) shims.
- (3) Align keyway in armature assembly to shaft key. Using driver and a hammer or arbor press, drive the armature assembly down over the shaft until it bottoms on the shims. A distinct sound change will be noted if driving with a hammer. (Ref. figure 12-10)

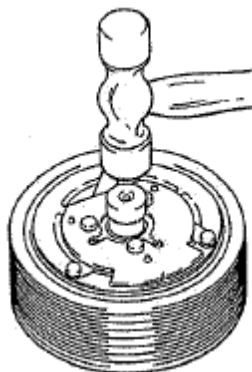

Figure 12 - 10

- (4) Replace retaining nut and torque to specification

1/2-20: 20-25 ft*lb (27-34 N*m)

M8: 11-15 ft*lb (15-21 N*m)

- (5) Check air gap with a feeler gauge. Specification is 0.011-0.019 in (0.3-0.5mm). If gap is not even around the clutch, gently tap down at the high spots. If the overall gap is out of spec, remove the armature assembly and change shims as necessary.

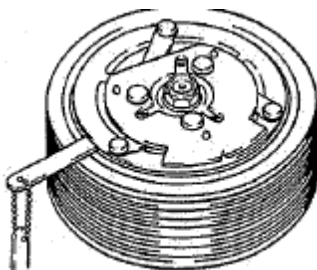

Figure 12 - 11

- (6) Replace armature dust cover (if used) and torque 3 or 6 bolts to specification below.

3-1/4-20 bolts: 2-4 ft*lb (2-5 N*m)

6-M5 bolts: 5-8 ft*lb (7-11 N*m)

NOTE: Over torque of dust cover bolts will cause air gap to become out of spec.



DATE:
08/04/2023

DOC No.:
IFSE-0007

REV:
F-1

PAGE:
26 of 99

TITLE:
Air Conditioning System Installation Instructions For Continued
Airworthiness for Airbus Helicopters AS-350 B, C, D, D1, B1, B2, B3, BA &
EC-130 B4

Section 12-30-00 System Leak Check

1. General

Identification and elimination of system fitting leaks is extremely important to the operation of this air conditioning system installation.

A system which contains a partial charge of refrigerant can be leak tested with the aid of an electronic leak detector and be recharged without evacuating the system.

A new or empty system can be pressurized with nitrogen 70-80 psi (5.1-5.6 kgcm) or R134a 50 psi to conduct a leak survey. Do not use compressed air, for it can introduce moisture into the system causing degradation to the operation of the system.

The preferred method is to use an electronic leak detector in conjunction with a small charge of R134a refrigerant. All checks done in this manner should be conducted with the air conditioner off. Since the refrigerant is heavier than air, leaks are most likely to be detected on the underside of the hoses and fittings. Refrigerants will collect in low areas and provide erroneous leak detection. A stream of compressed air from a nozzle may be useful in clearing the area just prior to conducting a leak test.

If the nitrogen method is used, it will be necessary to mix together a water and mild soap solution. Each fitting or suspected leak area should be brushed with this soap solution and watched for evidence of bubbles formed by the escaping nitrogen.

If a leak is detected at an O-ring fitting, check to ensure proper torque has been applied to the fitting. If the system continues to leak, evacuate the system of refrigerant and install a new O-ring. NOTE: be sure that the O-ring is lubricated with refrigerant oil prior to its installation.

A small amount of leakage (approximately one ounce per year) past the compressor shaft seal is normal. Most leak detectors are sensitive enough to show a leak a magnitude.

Section 12-40-00 Fitting Torque Procedures

1. Fitting Torque Procedures and Torque Values

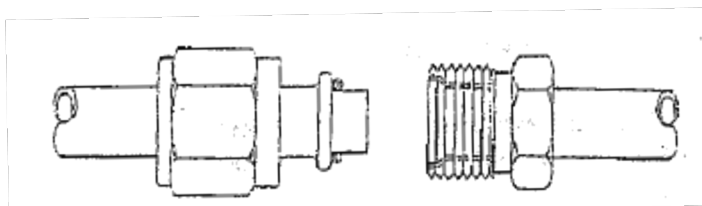

Figure 12 – 12: Insert O-Ring Fittings

- (1) Confirm there is no damage on fittings.
- (2) Apply a thin coating of refrigerant oil to O-ring and female side of fitting.
- (3) Slide B-nut back away from the end of the tube so the O-ring can be seen as the fitting is being slide together. Be careful not to pinch the O-ring during assembly.
- (4) Engage the male end into the female fitting being careful to maintain alignment.
- (5) The male flange should seat fully against the female fitting without the O-ring being pinched.
- (6) It is important to hold the fitting together while sliding the B-nut forward and engaging the threads. Tighten the B-nut by hand and torque per table 12-01. **DO NOT OVER TORQUE.**

Table 12-01 Fitting Torque Values

Fitting #	Torque Value in/lbs (Nm)
#6	30-35 (3.4-4.0)
#8	40-45 (4.6-5.1)
#10	50-55 (5.7-6.3)



DATE:
08/04/2023

DOC No.:
IFSE-0007

REV:
F-1

PAGE:
28 of 99

TITLE:
Air Conditioning System Installation Instructions For Continued
Airworthiness for Airbus Helicopters AS-350 B, C, D, D1, B1, B2, B3, BA &
EC-130 B4

Section 12-50-00 Normal Operation Functional Test

- a. With the aircraft engine operating, electrical system on and functioning normally, move the air conditioner control switch to the "FAN" position.
- b. Move the cockpit fan switch from "LOW" to "HIGH" speed and ensure that air output is present in all the forward air outlets. Repeat the test using the aft cabin fan speed selector switch for the aft cabin air outlets.
- c. Reposition the air conditioner control switch to the "A/C" position and repeat Step 2 above. Cool air should be supplied to the cockpit and cabin vents after a time delay of 15 seconds.
- d. Turn air conditioner switch to "OFF" or the center position. Entire system should shut down.

Section 12-60-00 Belt Tension Procedure

With the compressor drive belt on the drive pulley and the compressor clutch pulley. Tighten bolts at the adjustment arm assuring the belt proper amount of tension. Tighten the lower forward mounting bolt. Use a pull scale to measure the tension. (Ref. figure 12-13). Recommended belt tension values if using a grooved belt is 30 lbs and if using a flat belt is 50 lbs.

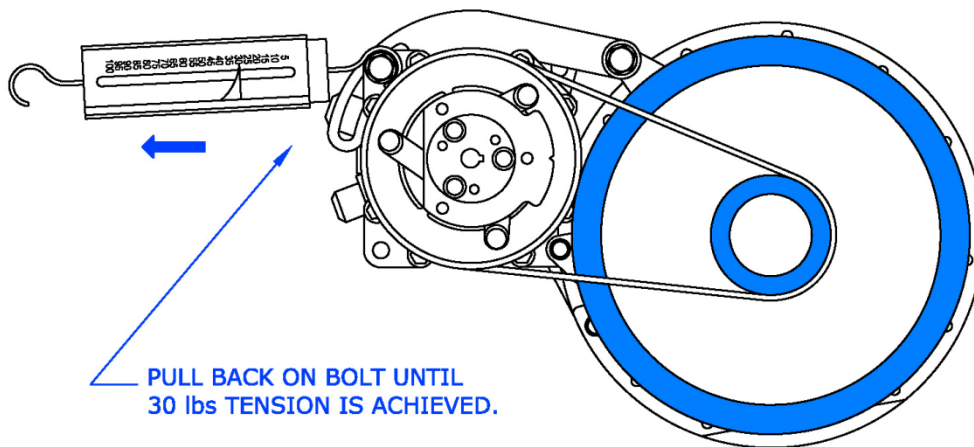

060005 GROOVED BELT

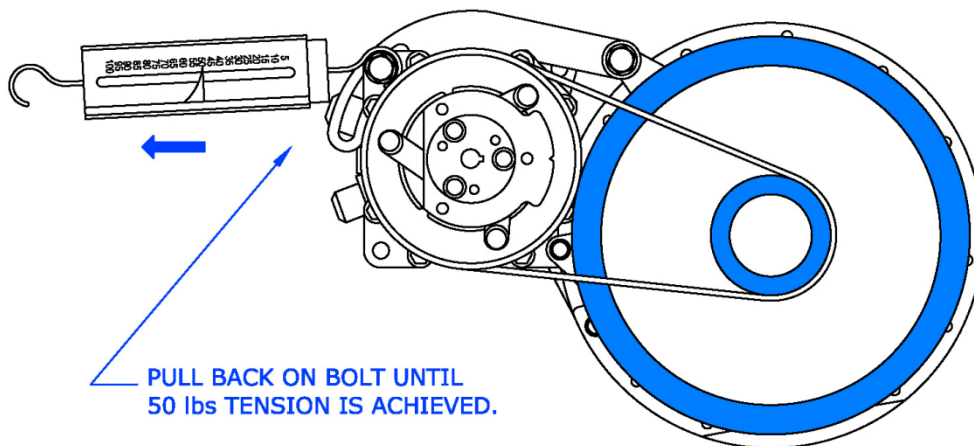

060018-1 FLAT BELT

Figure 12 – 13



DATE:
08/04/2023

DOC No.:
IFSE-0007

REV:
F-1

PAGE:
30 of 99

TITLE:
Air Conditioning System Installation Instructions For Continued
Airworthiness for Airbus Helicopters AS-350 B, C, D, D1, B1, B2, B3, BA &
EC-130 B4

Section 12-70-00 Drive Belt Change Procedure

- a. Access the compressor installation (ref. Section 6-00-00 Dimensions and Access). For compressor information reference Section 21-00-00 Air Conditioning.
- b. Place a support on the transmission deck to support the engine drive while the shaft is disconnected for belt installation.
- c. Remove the cotter pins from the four pins holding the “Gimble Ring” at the Thomas coupling.
- d. Slide the “Gimble Ring” aft to gain access to the Thomas coupling.
- e. Remove the 6 bolts and Thomas coupling connecting the drive shaft and shift slightly aft.
- f. Install two (2) Compressor Drive belts.
- g. Reassemble the Thomas coupling.
- h. Secure 1 belt to the outside of the drive shaft cover for a spare and slip one through the housing and over the drive pulley.
- i. Install the “Gimble Ring” pins and cotter pins. Remove supports.
- j. Install the compressor drive belt on the drive pulley and the compressor clutch pulley. Tighten bolts at the adjustment arm assuring the belt proper amount of tension. (Ref. Section 12-60-00 Belt Tension Procedure). Tighten the lower forward mounting bolt.



DATE:
08/04/2023

DOC No.:
IFSE-0007

REV:
F-1

PAGE:
31 of 99

TITLE:
Air Conditioning System Installation Instructions For Continued
Airworthiness for Airbus Helicopters AS-350 B, C, D, D1, B1, B2, B3, BA &
EC-130 B4

Chapter 20

Section 20-00-00 Standard Practices

This chapter contains maintenance information and procedures that are common standard practices. Information contained in this chapter is standard torque charts and application procedures, corrosion prevention, painting, mechanical fastener sealing, and dye penetrant inspection techniques.

Section 20-10-00 Torques Maintenance Practices

1. Torque Wrenches

a) Torque Wrench Accuracy

Torque wrenches must be of good quality and calibrated at least once a year. Any torque wrench that has been dropped or abused should be calibrated to ensure continued accuracy.

b) Application of Torque Wrench Loads

- (1) Be sure the bolt and nut and the surface they bear on are clean and dry, unless otherwise specified by the manufacturer.
- (2) Run the nut down to near contact with the washer or bearing surface and check the friction drag torque required to turn the nut. Add the friction drag torque to the desired torque to arrive at the "final torque" to be registered on the torque wrench indicator.
- (3) Whenever possible, apply the torque to the nut instead of the bolt. This will reduce rotation of the bolt in the hole and reduce wear.
- (4) Apply a smooth even pull when applying torque pressure.
- (5) If special adapters are used which will change the effective length of the torque wrench, the final torque indication or wrench setting must be adjusted accordingly. To determine the torque wrench setting or indication with adapter installed reference Figure 20-01.

TITLE:
Air Conditioning System Installation Instructions For Continued Airworthiness for Airbus Helicopters AS-350 B, C, D, D1, B1, B2, B3, BA & EC-130 B4

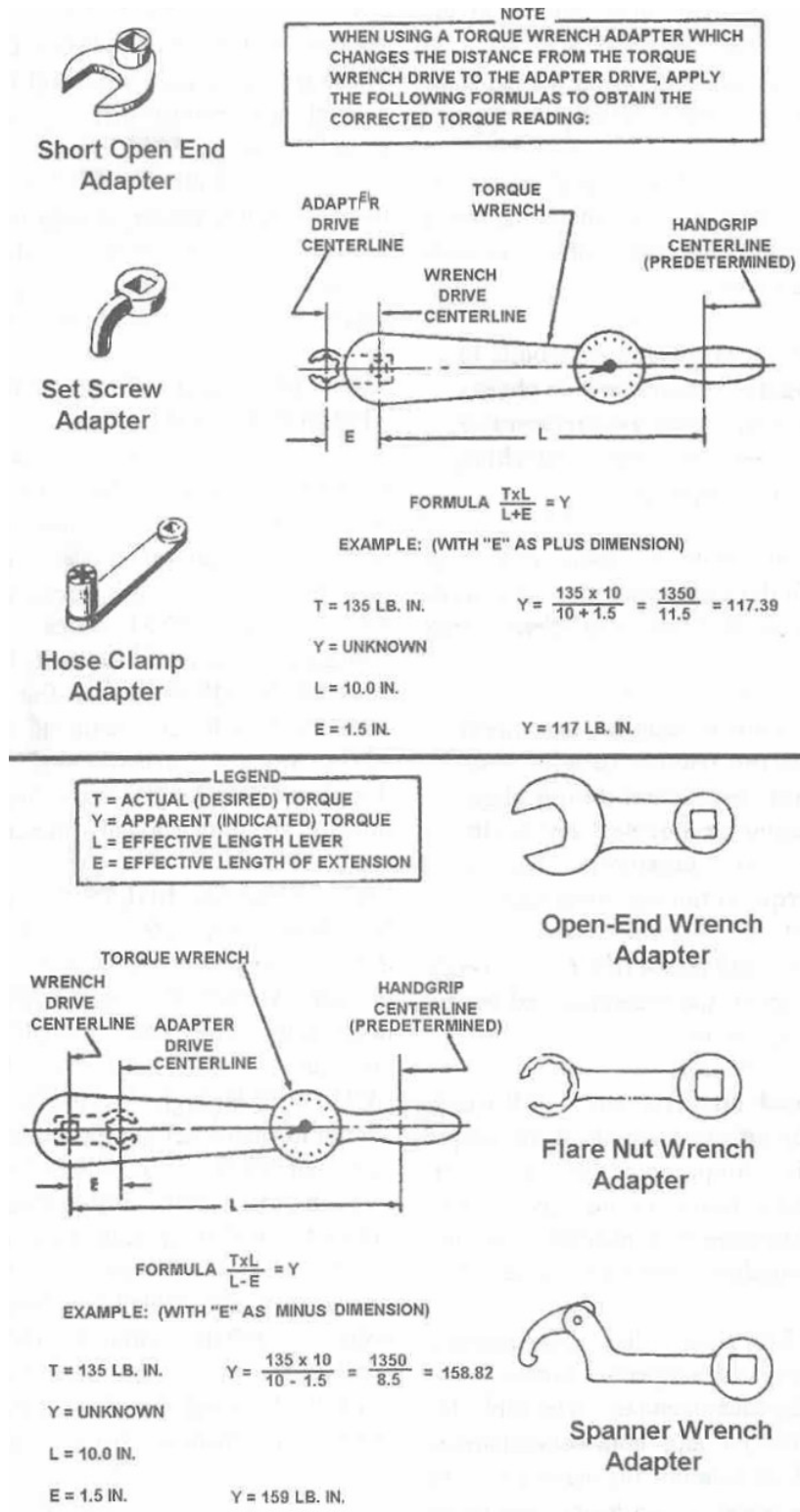

Figure 20 - 1: Torque Wrenches and Adapters

2. Torque Values

Warning: Do not exceed maximum allowable torque value. Overstressing of fastener may result.

Standard hardware torque values are given in the following **Table 20 - 1** through **Table 20 - 3**. **Table 20 - 1** gives recommended torque values for fine thread fasteners, shear and tension applications. **Table 20 - 2** gives recommended torque values for coarse thread fasteners, shear and tension applications. **Table 20 - 3** gives recommended torque values for Phillips-head screws.

Table 20 - 1: Recommended Torque Values for Fine-Thread Fasteners

Thread Size Fractional (decimal)	Shear		Tension	
	Recommended in-lb (N-m)	Maximum in-lb (N-m)	Recommended in-lb (N-m)	Maximum in-lb (N-m)
8-36 (0.1640-36)	7-9 (0.79-1.02)	12 (1.36)	12-15 (1.36-1.69)	20 (2.26)
10-32 (0.1900-32)	12-15 (1.36-1.69)	25 (2.82)	20-25 (2.25-2.82)	40 (4.51)
1/4-28 (0.2500-28)	30-40 (3.38-4.51)	60 (6.77)	50-70 (5.64-7.90)	100 (11.29)
5/16-24 (0.3125-24)	60-85 (6.77-9.60)	140 (15.81)	100-140 (11.29-15.81)	225 (25.41)
3/8-24 (0.3750-24)	95-110 (10.73-12.42)	240 (27.11)	160-190 (18.07-21.46)	390 (44.05)
7/16-20 (0.4375-20)	270-300 (30.49-33.88)	500 (56.48)	450-500 (50.83-56.48)	840 (94.88)
1/2-20 (0.5000-20)	290-410 (32.75-46.31)	660 (74.55)	480-690 (54.22-77.94)	1,100 (124.25)
9/16-18 (0.5625-18)	480-600 (54.22-67.77)	960 (108.44)	800-1,000 (90.36-112.96)	1,600 (180.73)
5/8-18 (0.6250-18)	660-780 (74.55-88.10)	1,400 (158.14)	1,100-1,300 (124.25-146.84)	2,400 (271.10)
3/4-16 (0.7500-16)	1,300-1,500 (146.84-169.44)	3,000 (338.88)	2,300-2,500 (259.80-282.40)	5,000 (564.80)
7/8-14 (0.8750-14)	1,500-1,800 (169.44-203.32)	4,200 (474.43)	2,500-3,000 (282.40-338.88)	7,000 (790.72)
1-12 (1.0000-12)	2,200-3,300 (248.51-372.76)	6,000 (677.76)	3,700-5,500 (417.95-621.28)	10,000 (1129.6)
1-1/8-12 (1.1250-12)	3,000-4,200 (338.88-474.43)	9,000 (1016.6)	5,000-7,000 (564.80-790.72)	15,000 (1694.4)
1-1/4-12 (1.2500-12)	5,400-6,600 (609.98-745.53)	15,000 (1694.4)	9,000-11,000 (1016.6-1242.6)	25,000 (2824.0)



TITLE:
Air Conditioning System Installation Instructions For Continued Airworthiness for Airbus Helicopters AS-350 B, C, D, D1, B1, B2, B3, BA & EC-130 B4

Table 20 - 2: Recommended Torque Values for Coarse-Thread Fasteners

Thread Size Fractional (decimal)	Shear		Tension	
	Recommended in-lb (N-m)	Maximum in-lb (N-m)	Recommended in-lb (N-m)	Maximum in-lb (N-m)
8-32 (0.1640-32)	7-9 (0.79-1.02)	12 (1.36)	12-15 (1.36-1.69)	20 (2.26)
10-24 (0.1900-24)	12-15 (1.36-1.69)	21 (2.37)	20-25 (2.25-2.82)	35 (3.95)
1/4-20 (0.2500-20)	25-30 (2.82-3.38)	45 (5.08)	40-50 (4.51-5.64)	75 (8.47)
5/16-18 (0.3125-18)	48-55 (5.42-6.21)	100 (11.29)	80-90 (9.03-10.16)	160 (18.07)
3/8-16 (0.3750-16)	95-100 (10.73-11.29)	170 (19.20)	160-185 (18.07-20.89)	275 (31.06)
7/16-14 (0.4375-14)	140-155 (15.81-17.50)	280 (31.62)	235-255 (26.54-28.8)	475 (53.65)
1/2-13 (0.5000-13)	240-290 (27.11-32.75)	520 (58.73)	400-480 (45.18-54.22)	880 (99.40)
9/16-12 (0.5625-12)	300-420 (33.88-47.44)	650 (73.42)	500-700 (56.48-79.07)	1,100 (124.25)
5/8-11 (0.6250-11)	420-540 (47.44-60.99)	900 (101.66)	700-900 (79.07-101.66)	1,500 (169.44)
3/4-10 (0.7500-10)	700-950 (79.07-107.31)	1,500 (169.44)	1,150-1,600 (129.90-180.73)	2,500 (282.40)
7/8-9 (0.8750-9)	1,300-1,800 (146.84-203.32)	2,700 (474.43)	2,200-3,000 (248.51-338.88)	4,600 (519.61)
1-8 (1.0000-8)	2,200-3,000 (248.51-338.88)	4,500 (508.32)	3,700-5,000 (417.95-564.80)	7,600 (858.49)
1-1/8-8 (1.1250-8)	3,300-4,000 (372.76-451.84)	7,200 (813.31)	5,500-6,500 (621.28-734.24)	12,000 (1355.5)
1-1/4-8 (1.2500-8)	4,000-5,000 (451.84-564.80)	10,000 (1129.6)	6,500-8,000 (734.24-903.68)	16,000 (1807.4 N m)



DATE:
08/04/2023

DOC No.:
IFSE-0007

REV:
F-1

PAGE:
36 of 99

TITLE:
Air Conditioning System Installation Instructions For Continued
Airworthiness for Airbus Helicopters AS-350 B, C, D, D1, B1, B2, B3, BA &
EC-130 B4

Table 20 - 3: Recommended Torque Values for Phillips-Head Fasteners

Thread Size Fractional (decimal)	Recommended in-lb (N-m)	Maximum in-lb (N-m)
8-32 (0.1640-32)	12-15 (1.36-1.69)	23 (2.59)
10-32 (0.1900-32)	20-25 (2.25-2.82)	35 (3.95)
1/4-28 (0.2500-28)	60-70 (6.77-7.90)	90 (10.16)
5/16-24 (0.3125-24)	110-125 (12.42-14.12)	150 (16.94)
3/8-24 (0.3750-24)	150-175 (16.94-19.76)	225 (25.41)
7/16-20 (0.4375-20)	230-280 (25.98-31.62)	450 (50.83)
1/2-20 (0.5000-20)	550-650 (62.12-73.42)	850 (96.01)
9/16-18 (0.5625-18)	750-900 (84.72-101.66)	1,200 (135.55)
5/8-18 (0.6250-18)	1,100-1,300 (124.25-146.84)	1,600 (180.73)



DATE:
08/04/2023

DOC No.:
IFSE-0007

REV:
F-1

PAGE:
37 of 99

TITLE:
Air Conditioning System Installation Instructions For Continued
Airworthiness for Airbus Helicopters AS-350 B, C, D, D1, B1, B2, B3, BA &
EC-130 B4

Section 20-30-00 Painting Maintenance Practices

The following procedures should be used to touch-up paint flaking, scratches, nicks, and gouges in system components.

Warning: Cleaning solvents and epoxy primer are flammable. Cleaning solvents, epoxy primer, and alodine can cause burns and irritation when skin is contacted. Vapors are harmful and caustic to eyes; goggles must be worn for eye protection. Cleaning solvents and alodine are poisonous. Vapors are harmful to life or health; work should be performed with proper ventilation and / or respirators should be worn while working with cleaning solvents, epoxy primer and alodine.

1. Paint Touch-Up of Small Areas

Use the following procedures to touch-up paint of small sanded areas and nicks, scratches, gouges, etc., that do not go through paint and primer to bare metal.

- a. Wipe surface clean with trichloroethane, MIL-T-81533, or equivalent cleaning solvent, and wipe dry immediately.
- b. Apply coat of epoxy polyamide primer, MIL-P-23377F or equivalent, to match original. Feather primer coating onto surrounding color coat. Allow primer to air dry for 30 minutes.
- c. Apply topcoat to match original finish.

Section 20-40-00 Corrosion Control Maintenance Practices

1. Corrosion Control

The system components are fabricated primarily of steel and aluminum, and should be inspected regularly for any signs of corrosion. The following procedures should be used for removing corrosion and treating affected areas.

2. Corrosion Removal

Remove corrosion by either chemical or mechanical means.

a) Paint Removal, Chemical

Caution: Do not use chemical paint stripper on composite materials. Chemical paint strippers can cause composite components to de-bond and / or lose adhesion of the epoxy matrix.

- (1) Mask all non-metallic surfaces in area to be stripped as well as areas where solution may get entrapped.

Warning: Paint stripper can cause burns and irritation when it contacts skin; proper gloves should be worn. Vapors are harmful and caustic to eyes; goggles must be worn for eye protection. Paint stripper is poisonous. Vapors are harmful to life or health; work should be performed with proper ventilation and / or respirators should be worn while working with paint stripper.

- (2) Using a fiber brush, apply sufficient paint stripper (Turco 5873) to cover area of removal.

Note: If paint stripper evaporates quickly or works slowly, cover area with plastic sheet.

- (3) Allow paint remover to remain on surface for a time sufficient to cause wrinkling and lifting of paint (about 10-30 minutes).
- (4) Using non-metallic scraper or abrasive pads (3M Scotchbrite 63) scrub area to further loosen paint.
- (5) Reapply paint stripper (Turco 5873) as necessary in areas where paint remains tightly adherent.

(6) Wash and scrub surface with demineralized water and alkaline cleaner to neutralize paint stripper.

(7) Remove masking materials and any residual paint or stripper

(8) Rinse with demineralized water.

b) Paint Removal, Mechanical

Caution: Do not sand into or expose composite fibers. Do not remove more material than necessary. Do not use aluminum oxide abrasive materials on epoxy/graphite materials.

Use abrasive flap wheel, abrasive disk, abrasive paper, or plastic media blast to remove paint.

c) Corrosion Removal

Note: Aircraft shall be electrically grounded during corrosion removal operations. When removing exterior corrosion from electronic boxes, the unit case shall be electrically grounded during the complete operation.

(1) Corrosion shall be removed by the mildest method possible.

(a) Hand scrub with dry non-metallic brush/pad (3M pad).

(b) Use abrasive cloth (Aluminum oxide 240 grit). Caution: Do not use on epoxy/graphite materials.

(c) Use 320-grit sandpaper.

(d) Glass bead blast.

(e) Use 240-grit abrasive wheel.

Note: On high-strength steel, do not use power tools other than a flap brush or mandrel with abrasive material; overheating and notching may occur.

(2) Ensure all active corrosion and corrosion products have been removed.

(3) Using 320-grit sandpaper, blend edges of paint (if applicable) surrounding repair area to create a smooth transition. Vacuum the area thoroughly to remove all contaminants.

(4) Apply aluminum surface treatment if applicable. (Ref. Section 4 of 20-40-00, Aluminum Alloy Surface Touch-Up Treatment).

(5) Touch-up primer and paint to match original.

3. Mechanical Defects (Nicks, Scratches, Gouges, Etc.)

- a) Section 20-30-00 Painting Maintenance Practices).
- b) If damage is through the paint surface, prepare area for paint touch-up using the following methods.

Note: On high-strength steel, do not use power tools other than a flap brush or mandrel with abrasive material; overheating and notching may occur.

- (1) Remove defect using flap wheel, abrasive disk, abrasive paper, or plastic media blast.
- (2) Using 320-grit sandpaper, blend edges of paint surrounding repair area to create a smooth transition.
- (3) Apply aluminum surface treatment if applicable. (Ref. Section 4 of 20-40-00, Aluminum Alloy Surface Touch-Up Treatment).
- (4) Touch-up primer and paint to match original.

4. Aluminum Alloy Surface Touch-Up Treatment

Note: If there is any question as to whether or not the protective coating is removed, surface treatment shall be applied.

Warning: Alodine and solvents can cause burns and irritation when it contacts skin; proper gloves should be worn. Vapors are harmful and caustic to eyes; goggles must be worn for eye protection. Alodine is poisonous. Vapors are harmful to life or health; work should be performed with proper ventilation and / or respirators should be worn while working with solvents and alodine. Solvent cleaners are flammable.

- a) Scuff surface using 3M Scotchbrite 63 cellulose/nylon scouring pad.
- b) Wipe exposed surface with isopropyl alcohol or aliphatic naphtha. Allow area to air dry for 10 minutes. Do not touch or otherwise contaminate surface after solvent wipe.



DATE:
08/04/2023

DOC No.:
IFSE-0007

REV:
F-1

PAGE:
41 of 99

TITLE:
Air Conditioning System Installation Instructions For Continued
Airworthiness for Airbus Helicopters AS-350 B, C, D, D1, B1, B2, B3, BA &
EC-130 B4

- c) Apply Alodine 1200 or equivalent with cotton swab, non-metallic brush, or by dipping. Maintain moist surface for 1-3 minutes with repeated application. Surface will become amber or brown in color.
- d) Irrigate surface with demineralized or distilled water to remove surface treatment chemical. Allow to air dry for approximately 1 hour.
- e) If there is any surface without color change, repeat procedure.
- f) Apply paint touch-up as required (Ref Section 20-30-00 Painting Maintenance Practices).

Section 20-50-00 Mechanical Fastener Sealing Methods

Remove existing cracked, chipped or broken existing sealing compound and thoroughly clean with solvent. Reseal using MIL-S-8802, sealing compound, mixing per manufacturer's instructions.

Seal mechanical fasteners as shown:

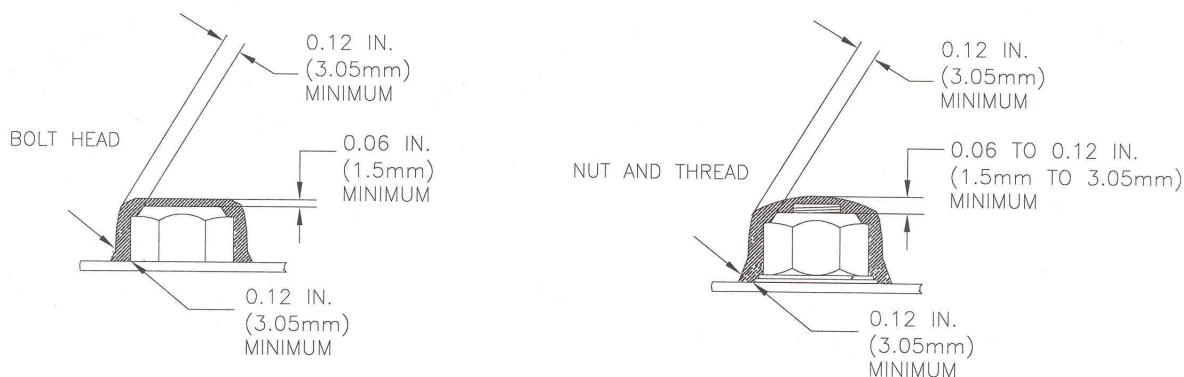

Figure 20 - 02: Mechanical Fastener Sealing

Section 20-90-00 Dye-Penetrant Inspection Methods

Warning: solvents can cause burns and irritation when it contacts skin; proper gloves should be worn. Vapors are harmful and caustic to eyes; goggles must be worn for eye protection. Vapors are harmful to life or health; work should be performed with proper ventilation and / or respirators should be worn while working with solvents. Solvent cleaners are flammable.

Use the following steps to perform dye-penetrant inspection:

1. Using cleaning solvent trichloroethane, MIL-T-81533, clean area to be inspected.
Note: Parts to be inspected must be dry and heated to at least 70° F (21.1° C), but not over 130° F (54.4° C).
Note: Manufacturer's instructions on Dye-Penetrant Kit take precedence over the following instructions.
2. Apply penetrant from dye-penetrant kit (ASTM E1417) by brushing, spraying, or by dipping. Allow to stand for a minimum of 2 minutes.
3. Remove excess penetrant with remover (available with dye-penetrant kit), or by cleaning with plain water. Allow part to dry.
4. Apply a light, even layer of developer from dye-penetrant kit by brushing, spraying, or by dipping. When dipping, avoid excess quantity.
5. Penetrant which has penetrated into cracks (or other openings) in the surface of the part will be drawn out by the developer, resulting in a bright red indication.
6. If part is serviceable or repairable, clean part free of penetrant and developer with trichloroethane (MIL-T-81533) cleaning solvent.

Chapter 21

Section 21-00-00 Air Conditioning

1. Description and Operation

The Air Conditioning System Installation consists of a belt driven vapor cycle air-conditioning system using R-134a as the refrigerant. The air conditioning system provides for cabin comfort during all operations, both in the ground and in flight. During ground operations when the engines are running, cooling may be provided.

This system consists of 4 major components:

- **Condenser-** The condenser is located in one of two positions depending on kit part number (Ref. table 21.1). The aft mounted condenser (Ref. figure 21-01) is mounted in the tail boom mounted 5 in. above the baggage floor. The side mounted condenser is located in the right baggage compartment (Ref. figure 21-02). The EC-130 condenser is only located in the aft mounted configuration. The aft mounted condenser assembly has two blower motors, whereas the side mounted condenser assembly only has one blower motor.
- **Compressor-** The compressor is located aft and to the left side on main transmission deck. The belt is secured to the outside of the drive shaft, in all configurations. If designated by the kit part number (Ref. tables 21-01 & 21-02), either a smooth pulley compressor or a grooved double V-belt pulley compressor is installed.
- **Aft Evaporator-** The aft evaporator is located on the right-hand upper transmission deck in all configurations.
- **Forward Evaporator-** In the AS-350 series, the forward evaporator is located on the cockpit floor forward of the pilots' controls. In the EC-130 kits, it is located forward of the pedestal and mounted to the pedestal.

Controls for the air conditioning system are located around or in the instrument panel, the specific location depending on the Kit number part as described in tables 21-01 and 21-02. All kits contain a Master Control Selector, which consists of a rocker type switch labeled, "A/C", "OFF" and "FAN." Selecting the "A/C" turns on the system's dual evaporator fans, compressor and condenser blower. The second rocker switch, also included with every kit, is for "HIGH," "MED" and "LOW" evaporator fan speed selection for the forward cockpit. An additional 2 position switch for the aft evaporator fan speed "HI/LOW" is present depending on the kit part numbers and the switch is located per that kit.



DATE:
08/04/2023

DOC No.:
IFSE-0007

REV:
F-1

PAGE:
45 of 99

TITLE:
Air Conditioning System Installation Instructions For Continued
Airworthiness for Airbus Helicopters AS-350 B, C, D, D1, B1, B2, B3, BA &
EC-130 B4

Table 21-1 Air Condition System Installation Kit Part Number Description AS-350 Series

AS-350 Series	
BASE KIT NUMBERS:	
350-00-011-HP	AEC Basic Configuration Side Mounted Condenser (Ref Figure 21-01)
350-00-031-HP	AEC Basic Configuration Aft Mounted Condenser (Ref Figure 21-02)

Table 21-2 Air Condition System Installation Kit Part Number Description EC-130 Series

EC-130B4	
BASE KIT NUMBER:	
130-00-031-HP*	Aft Mounted Condenser (Ref Figure 21-02)
CUSTOM CONFIGURATIONS:	
Corporate Configuration (Ref Figure 21-05)	

TITLE:
Air Conditioning System Installation Instructions For Continued
Airworthiness for Airbus Helicopters AS-350 B, C, D, D1, B1, B2, B3, BA &
EC-130 B4

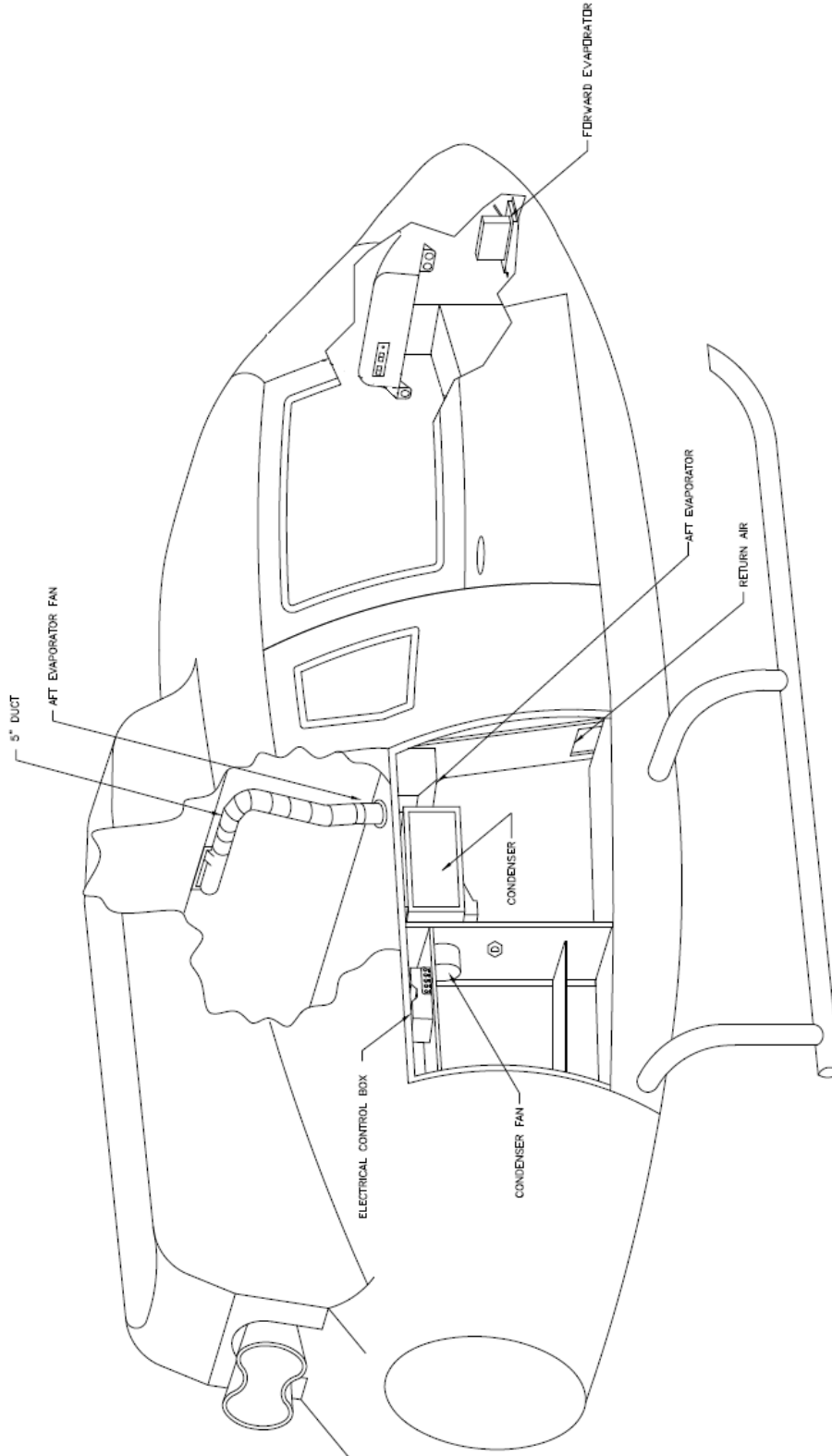

Figure 21-01: Equipment Locations for Air Conditioning System
with the -011 Configuration (Side Mounted Condenser)

TITLE:
Air Conditioning System Installation Instructions For Continued
Airworthiness for Airbus Helicopters AS-350 B, C, D, D1, B1, B2, B3, BA &
EC-130 B4

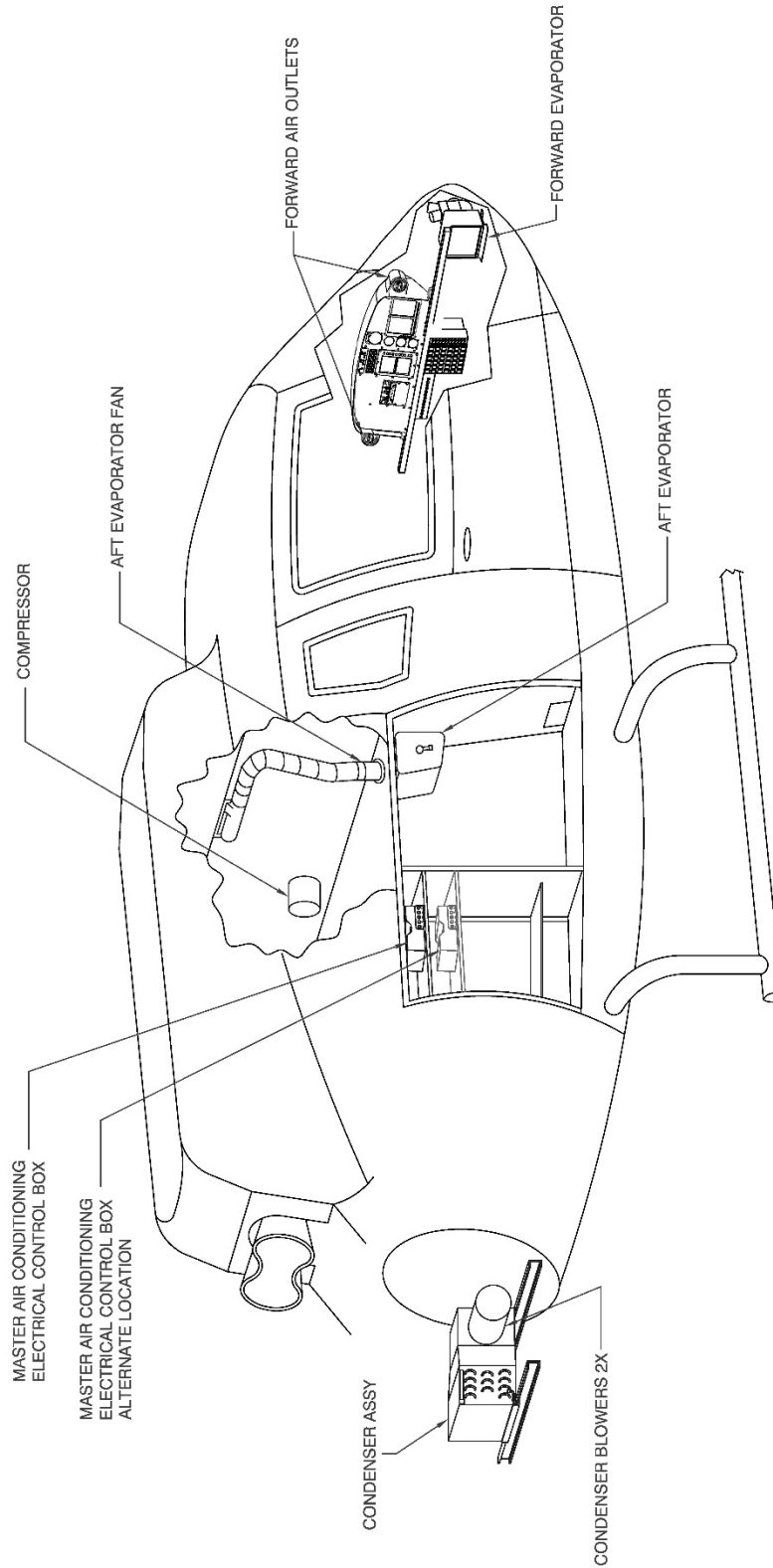
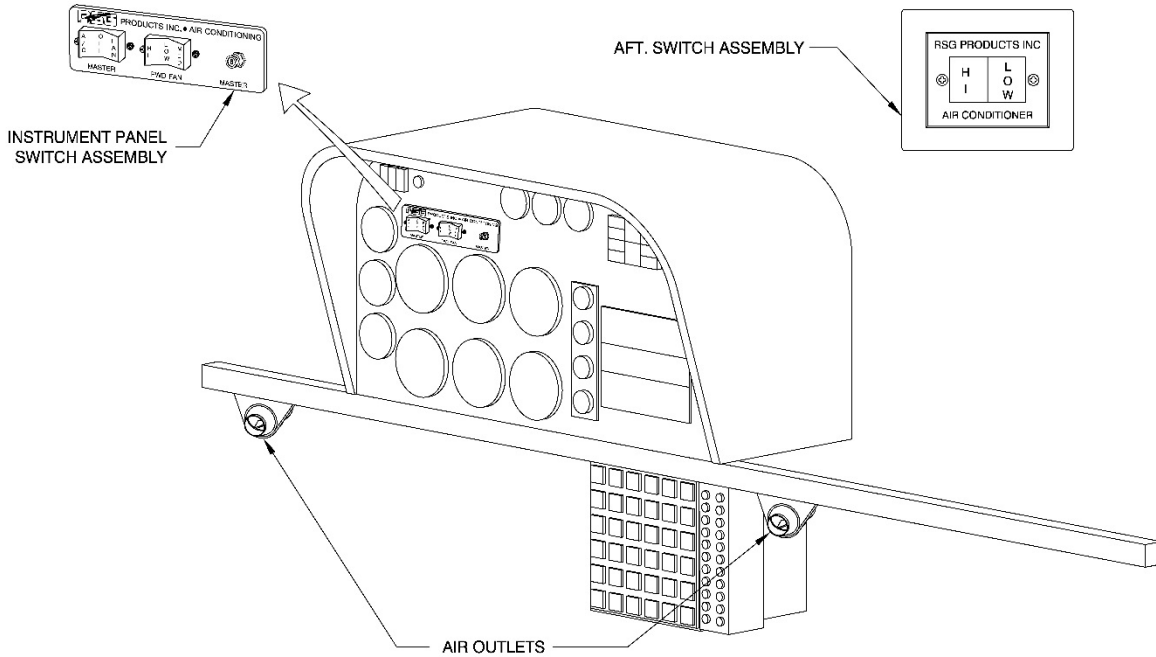
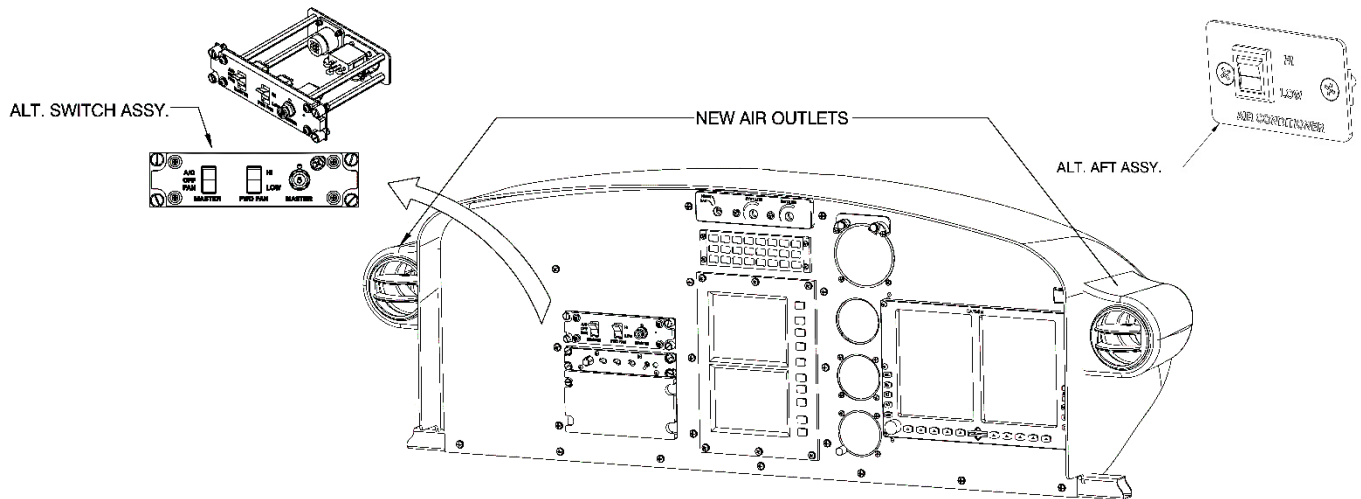

Figure 21-02: Equipment Locations for Air Conditioning System with the -031 Configuration (Aft Mounted Condenser)

TITLE:
Air Conditioning System Installation Instructions For Continued
Airworthiness for Airbus Helicopters AS-350 B, C, D, D1, B1, B2, B3, BA &
EC-130 B4



(AS350 Old configuration)



(AS350 New configuration)

Figure 21 - 03: AEC Basic Configuration
(Top - Old config. / Bottom - New config.)

TITLE:
Air Conditioning System Installation Instructions For Continued
Airworthiness for Airbus Helicopters AS-350 B, C, D, D1, B1, B2, B3, BA &
EC-130 B4

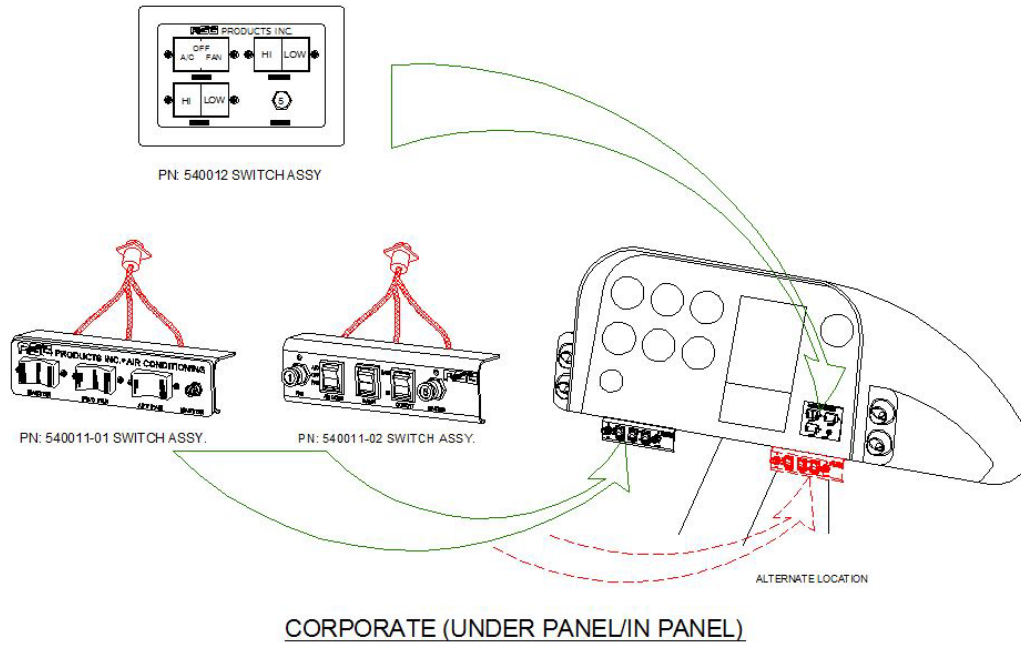

Figure 21 - 05: Corporate Configuration (EC130)

2. Removal/ Installation Forward Evaporator

(Ref. figures 21-06 and 21-07)

a) Removal

- 1) Access forward evaporator per Section 6-00-00 Dimensions and Access.
- 2) Connect refrigerant reclaimer to system in accordance with Section 21-00-00 and remove coolant from system. Comply with all Federal, State, and Local rules governing refrigerant handling.
- 3) Remove bolts securing evaporator.
- 4) Remove evaporator assembly.
- 5) Support evaporator while removing lines and other duct work.
- 6) Remove evaporator from aircraft.
- 7) Cap all open lines on unit and aircraft.
- 8) Disconnect electrical connections and remove evaporator fan.

b) Installation

- 1) Reinstall fan in aircraft and connect electrical connections.
- 2) Position evaporator against fan assembly and loosely install with securing hardware. Secure mounting hardware.
- 3) Reinstall drain line.
- 4) Connect duct work.
- 5) Ensure refrigerant O-rings are installed and in good condition. Replace as necessary. Oil all O-rings and fittings with refrigerant oil of the same type listed on the compressor. Torque refrigerant lines: #6 11-13 ft./lbs.; #8 15-20 ft./lbs.; #10 21-27 ft./lbs.
- 6) After completing other system functions and maintenance, charge system in accordance with Section 12-10-00.
- 7) Check for leaks per section 12-30-00

TITLE:
Air Conditioning System Installation Instructions For Continued
Airworthiness for Airbus Helicopters AS-350 B, C, D, D1, B1, B2, B3, BA &
EC-130 B4

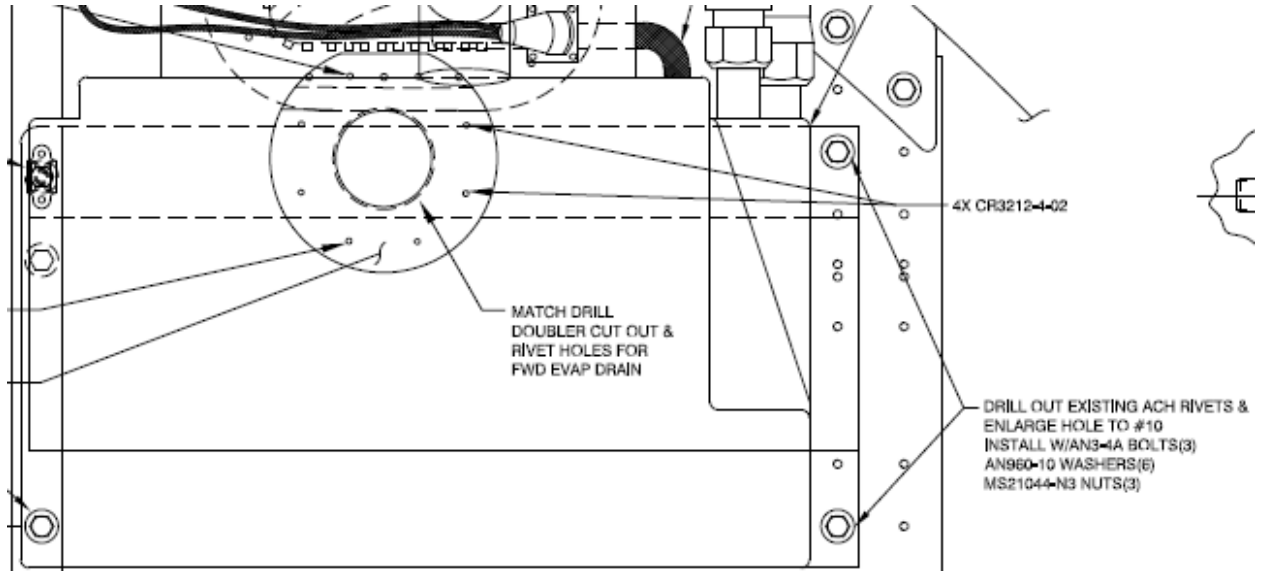

Figure 21 - 06: Forward Evaporator (AS-350)

FLUSH WITH PLATE, AND ATTACH WITH
5X AN3-5A BOLT
5X AN960-10 WASHER

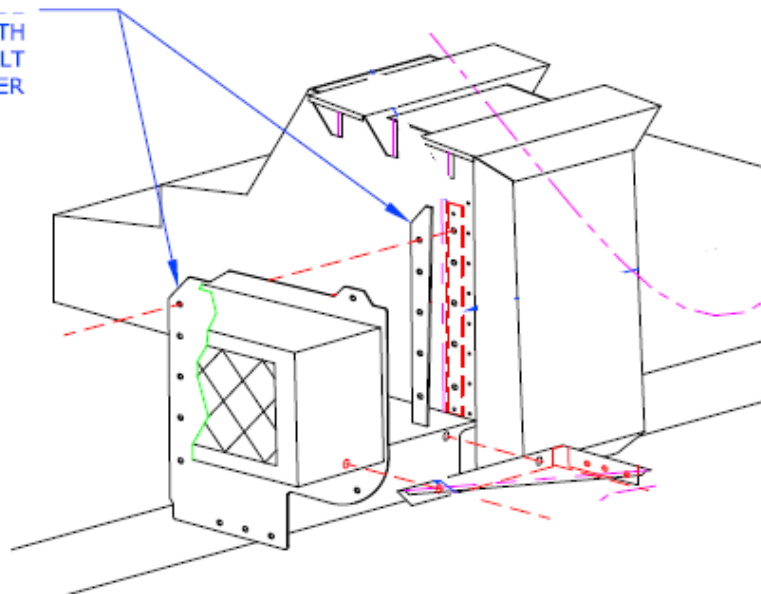

Figure 21 - 07: Forward Evaporator (EC-130)

3. Removal/ Installation Aft Evaporator

(Ref Figure 21-08)

a) Removal

- 1) Access aft evaporator (Ref. Section 6-00-00 Dimensions and access) and remove electrical connections.
- 2) Reclaim refrigerant in system in accordance with Section 12-10-00, to remove coolant from system.
- 3) Support evaporator while removing lines and duct work.
- 4) Cap all open lines on unit and aircraft.

b) Installation

- 1) Reinstall fan/evaporator and connect electrical connections.
- 2) Position evaporator and loosely install with securing hardware. Secure mounting hardware.
- 3) Reinstall drain line.
- 4) Connect duct work.
- 5) Ensure refrigerant O-rings are installed and in good condition. Replace as necessary. Oil all O-rings and fittings with refrigerant oil of the same type listed on the compressor. Torque refrigerant lines: #6 11-13 ft./lbs.; #8 15-20 ft./lbs.; #10 21-27 ft./lbs.
- 6) After completing other system functions and maintenance, charge system in accordance with Section 12-10-00.
- 7) Check for leaks per section 12-30-00.

TITLE:
Air Conditioning System Installation Instructions For Continued Airworthiness for Airbus Helicopters AS-350 B, C, D, D1, B1, B2, B3, BA & EC-130 B4

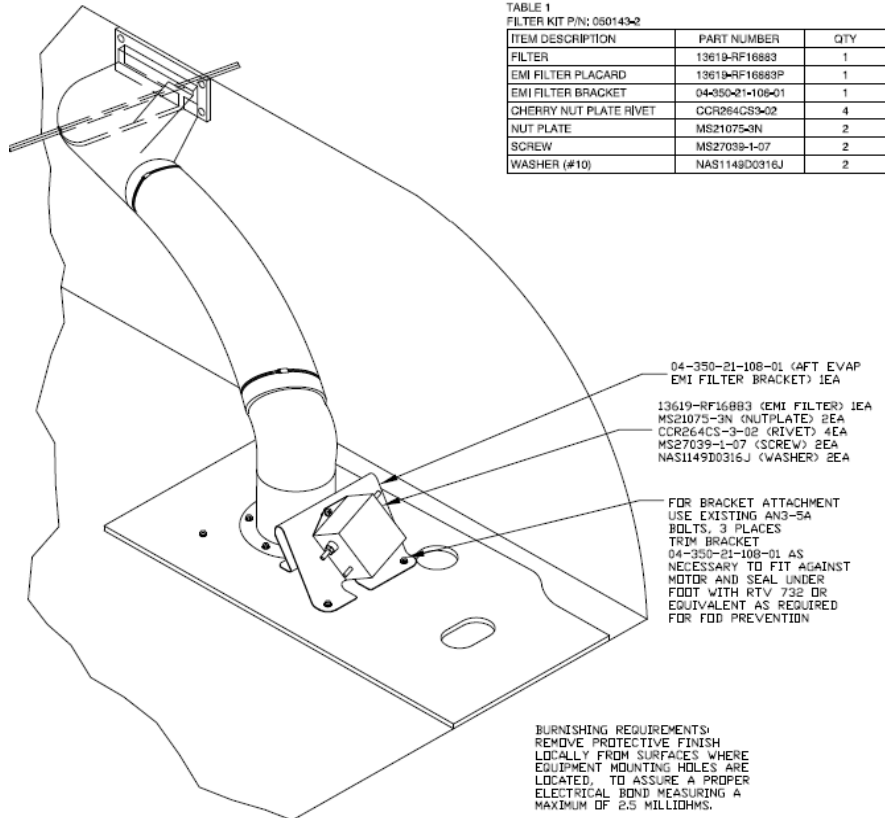

Figure 21 - 08: Aft Evaporator

4. Removal / Installation - Condenser

(Ref figures 21-09 and 21-10)

a) Removal

- 1) Access the condenser (Ref Section 6-00-00 Dimensions and Access)
- 2) Reclaim refrigerant in system in accordance with Section 12-10-00, to remove coolant from system.
- 3) Remove hardware securing condenser assembly. Disconnect blower wires and refrigerant hoses.
- 4) Remove condenser and cap all open lines on condenser and airframe.



DATE:
08/04/2023

DOC No.:
IFSE-0007

REV:
F-1

PAGE:
54 of 99

TITLE:
Air Conditioning System Installation Instructions For Continued
Airworthiness for Airbus Helicopters AS-350 B, C, D, D1, B1, B2, B3, BA &
EC-130 B4

b) Installation

- 1) Place condenser back in location.
- 2) Loosely install all hardware securing condenser assembly. Tighten mounting hardware only after all other hardware is installed.
- 3) Remove protective caps from refrigerant lines. Inspect that O-rings are installed and in good condition. Oil all O-rings and fittings with refrigerant oil of the same type listed on the compressor.
- 4) Install refrigerant lines. Torque refrigerant lines as follows: #6 11-13 ft./lbs.; #8 15-20 ft./lbs.; #10 21-27 ft./lbs. Do not over tighten.
- 5) Charge system in accordance with Section 12-10-00
- 6) Install 5" duct P/N: 060004

TITLE:
Air Conditioning System Installation Instructions For Continued
Airworthiness for Airbus Helicopters AS-350 B, C, D, D1, B1, B2, B3, BA &
EC-130 B4

BURNISHING REQUIREMENTS:
REMOVE PROTECTIVE FINISH LOCALLY FROM
SURFACES WHERE EQUIPMENT MOUNTING HOLES
ARE LOCATED, TO ASSURE A PROPER ELECTRICAL
BOND MEASURING A MAXIMUM OF 2.5 MILLIOHMS.

OPTIONAL INSTALL FOR NOISE REDUCTION WHEN BRUSHLESS
MOTORS ARE INSTALLED; P/Ns: IFSS 050143 DCB, -1 DCB,
-2 DCB, AND -3 DCB.
INSTALL THE FOLLOWING, MAINTAINING BURNISHING REQ:
13619-RF16883 (EMI FILTER) 2EA
MS27039-0807 (SCREW) 4EA
NAS620-8L (WASHER) 4EA

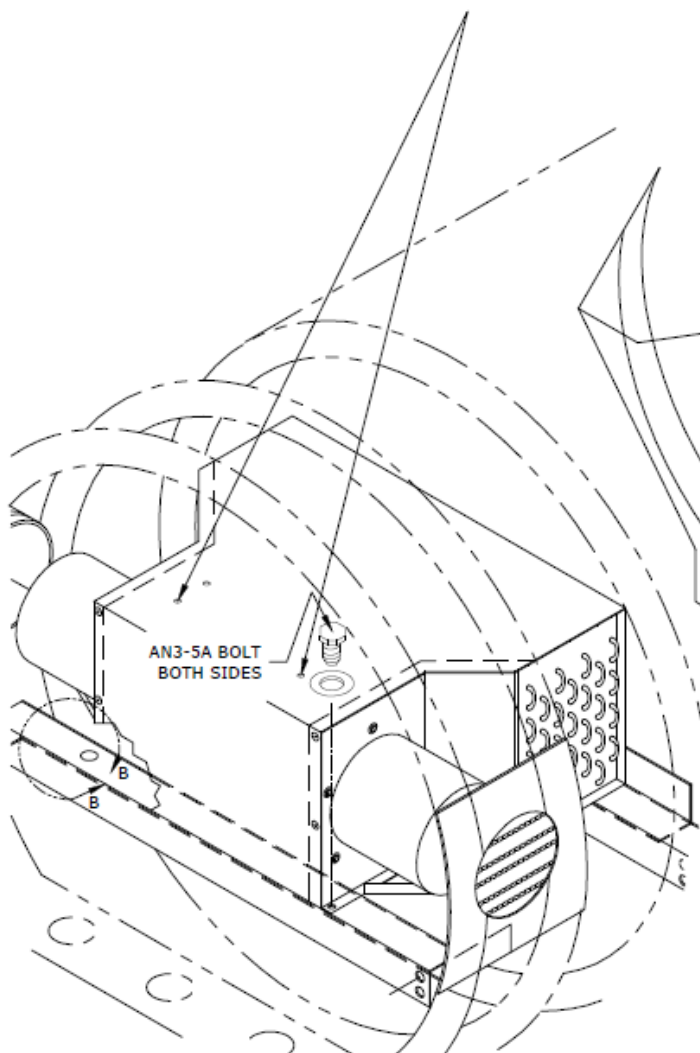

Figure 21 - 09: Aft Mounted Condenser (AS-350, EC-130)

TITLE:
Air Conditioning System Installation Instructions For Continued
Airworthiness for Airbus Helicopters AS-350 B, C, D, D1, B1, B2, B3, BA &
EC-130 B4

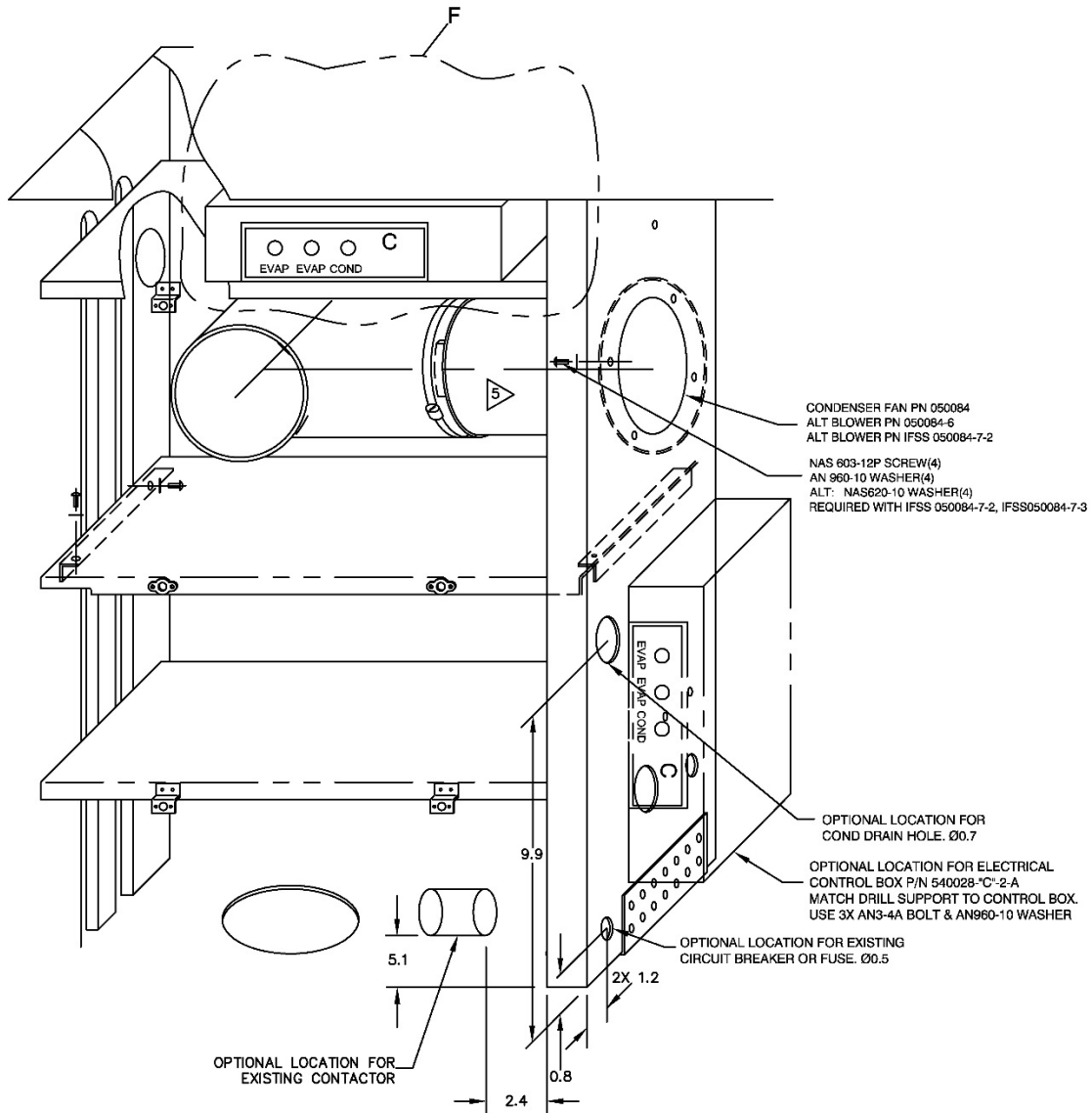

Figure 21 - 10: Side Mounted Condenser (AS-350)

5. Removal / Installation - Compressor

(Ref figure 21-11)

a) Removal

- 1) Access the compressor (Ref Section 6-00-00 Dimensions and Access)
- 2) Reclaim refrigerant in system in accordance with Section 12-10-00, to remove coolant from system.
- 3) Remove refrigerant lines from compressor and install protective caps to protect from foreign material entering system and compressor.
- 4) Disconnect drive belt to compressor.
- 5) Remove bolts securing compressor to mount and remove compressor.

b) Installation

- 1) Install compressor loosely on support frame with attaching hardware.
- 2) Install drive belt.
- 3) Tighten compressor bolts allowing compressor to "Seek" its own natural position on the frame. Tighten compressor belt tensioning bolt to 50 lbs. belt tension for PN 060018-1 Flat Belt, or 30 lbs. tension for PN 060005 Grooved Belt.
- 4) Tighten and safety all compressor mounting bolts.
- 5) Remove protective caps from refrigerant lines and compressor. Inspect the O-rings from installation and condition. Replace as necessary.
- 6) Oil all fittings and O-rings.
- 7) Install refrigerant lines.
- 8) Torque refrigerant lines: #6 11-13 ft./lbs.; #8 15-20 ft./lbs.; #10 21-27 ft./lbs. Do not over tighten.
- 9) Charge system in accordance with Section 12-00-00.
- 10) Install previously removed cowlings.

TITLE:
Air Conditioning System Installation Instructions For Continued
Airworthiness for Airbus Helicopters AS-350 B, C, D, D1, B1, B2, B3, BA &
EC-130 B4

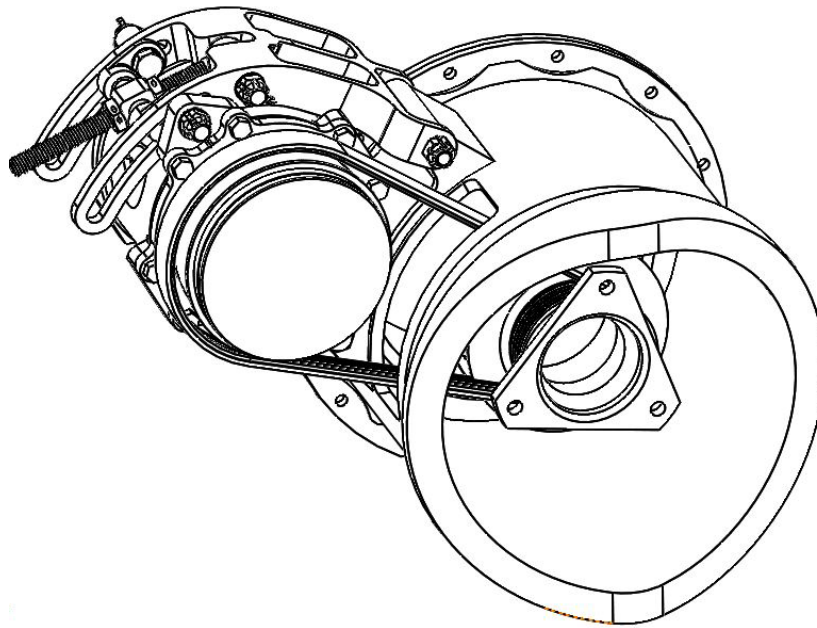

Figure 21 - 11: Compressor

6. Troubleshooting guide

Symptoms	Trouble	Cause	Correction
<ul style="list-style-type: none"> -Insufficient cooling -Low-side pressure too low -High -side pressure too low -Air in ducts only slightly cool 	Low or partial refrigerant charge	Leak	Find and fix the leak. If there was a loss of oil, be sure to check to compressor oil level. Evacuate and recharge per section 12.10.00
<ul style="list-style-type: none"> - Insufficient cooling during hottest part of the day or during extended flying. - Low-side pressure normal, though it may be too low or even a vacuum - High-side pressure normal, though it may be low-at the same time low side is low - Air in the ducts is usually cold, but becomes warm when pressure reading drop 	Excessive moisture in the system	The desiccant in the drier/receiver is saturated	Replace or rebuild the receiver/drier. Evacuate and recharge per section 12.10.00
<ul style="list-style-type: none"> - Insufficient cooling - Low-side pressure normal, but does not drop when the clutch cycles - High-side pressure high - Air in ducts only slight cool 	Air in the System	Refrigerant contains non-condensable in the form of air moisture	Leak test, watch for bad compressor seals. Drain the system. Repair leaks as needed. Replace or rebuild the receiver-drier. Check the compressor oil. Evacuate and recharge per section 12.10.00.
<ul style="list-style-type: none"> - No cooling - Low-side pressure too high - High-side pressure too high - Liquid line very hot - Air in ducts is warm 	Condenser malfunction or system overcharge	Condenser malfunction or system overcharge	Evacuate and recharge per section 12.10.00 or replace condenser.

Section 21-10-00 Illustrated Parts List

1. General

This section contains information on parts for the Air Conditioning System Installation, for use in ordering replacements if necessary.

Air Outlets

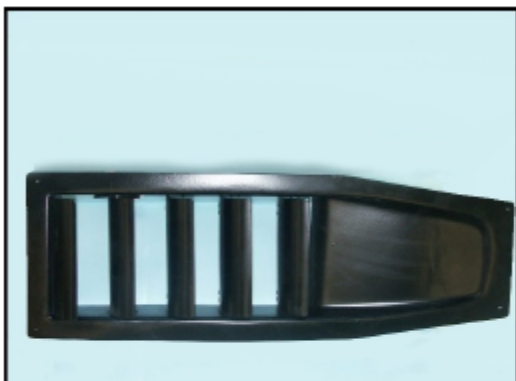

RSG PN: 520071-1
**Condenser Air Intake
Assembly Low Profile
(Sliding Door)**

AS350 



RSG PN: 500001
Left Side Air Outlet

EC130 



RSG PN: 500002
Right Side Air Outlet

EC130 

Air Outlets

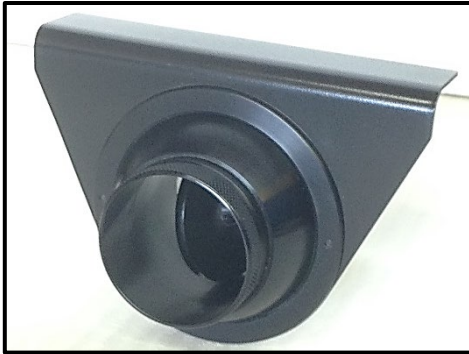

RSG PN: 510259-3
Air Outlet Assembly

AS350 

EC130 

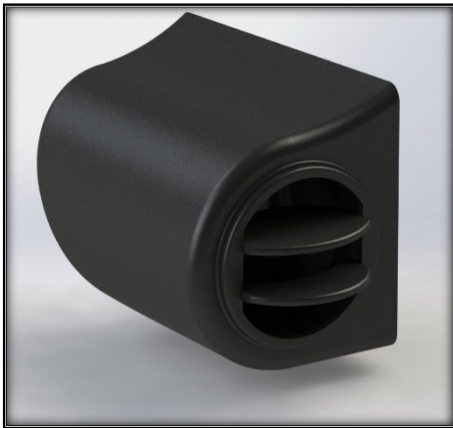

RSG PN: 520156HP-01
Air Outlet L.H.

AS350 

EC130 

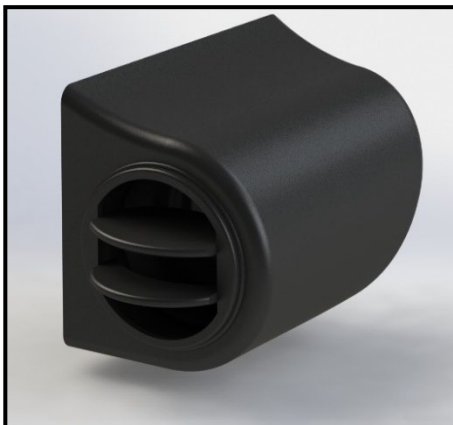

RSG PN: 520157HP-01
Air Outlet R.H.

AS350 

EC130 

Blower Motors



RSG PN:IFSS 050143-2 DCB
-3 DCB

**5" Vane Axial Blower
Assembly**

AS350 

EC130 



RSG PN: 050052-1
**Blower Motor,
Modified Right Half**

AS350 



RSG PN: 490017-1-02
**Aft Evaporator Fan
Assembly**

AS350 

TITLE:
Air Conditioning System Installation Instructions For Continued
Airworthiness for Airbus Helicopters AS-350 B, C, D, D1, B1, B2, B3, BA &
EC-130 B4

Blower Motor Part



RSG PN: 040004-8
Fan Wheel CW

AS350



EC130



Compressors



RSG PN: 590008
**Compressor
Assembly**

AS350 

EC130 

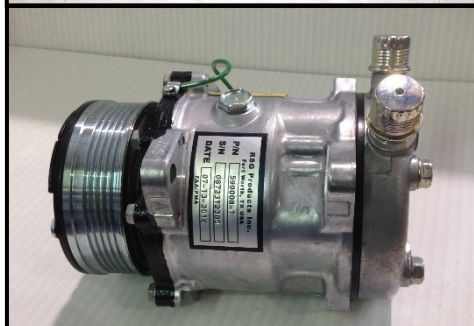

RSG PN: 590008-1
**Compressor
Assembly**

AS350 

EC130 

Compressor Parts



RSG PN: 050033
Coil, 24 VDC

AS350 

EC130 

Compressor Parts



RSG PN: 060005
**24.3" 4 Groove
Serpentine Belt**

AS350 

EC130 



RSG PN: 060018 25-1/4"
RSG PN: 060018-1 25"
Flat Belt

AS350 

EC130 

Compressor Bracket/Parts



RSG PN: 04-130-21-101-01
**Compressor Mount
Bracket**

AS350 

EC130 

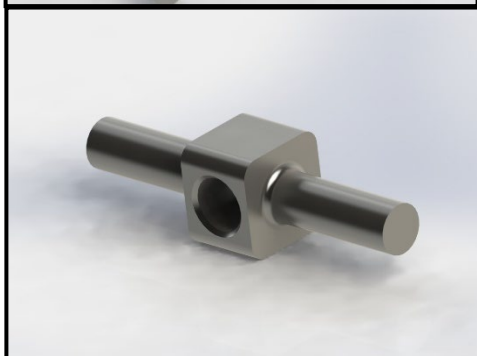

RSG PN: 04-130-21-102-01
**Compressor Mount
Tension Bolt**

AS350 

EC130 

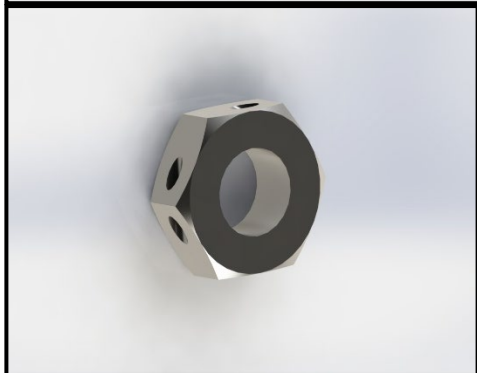

RSG PN: 04-130-21-104-01
Jam Nut Drilled

AS350 

EC130 

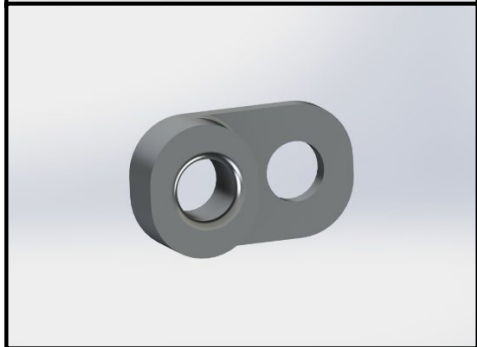

RSG PN: 04-130-21-105-01
Compressor Clamp

AS350 

EC130 

Compressor Bracket/Parts



RSG PN: 2434K39
Threaded Rod End

AS350



EC130



RSG PN: 530100-1
**Strap, Housing Mod
Assembly**

AS350



EC130



RSG PN: 300363-2
**Compressor Shim, Upper
(Alt: 261155 not shown)**

AS350



EC130



Compressor Bracket/Parts



RSG PN: 300067-1
Compressor Standoff

AS350 

EC130 



RSG PN: 261007
Bushings, SD507

AS350 

EC130 



RSG PN: 300095
Compressor Pin

AS350 

EC130 

Condenser/Evaporator



RSG PN: 090002-O
Expansion Valve

AS350 

EC130 



RSG PN: 090016-5
Receiver/Drier

AS350 

EC130 



RSG PN: 550003-O
**Aft Condenser
Assembly**

EC130 



RSG PN: 550007-1
**Side Condenser
Assembly**

AS350 

Condenser/Evaporator

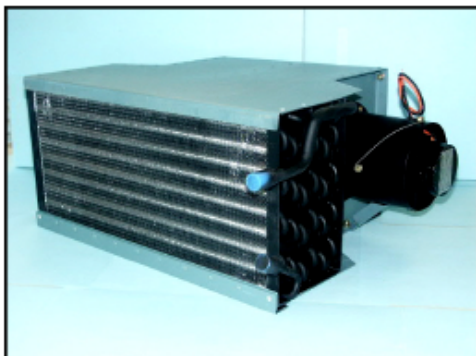

RSG PN: 550022
**Aft Condenser
Assembly**

AS350 



RSG PN: 560004
**Fwd Evaporator
Assembly**

EC130 



RSG PN: 560010-O-5
**Aft Evaporator
Assembly**

AS350 



RSG PN: 560016-O-1
**Aft Evaporator
Assembly**

EC130 

TITLE:
Air Conditioning System Installation Instructions For Continued
Airworthiness for Airbus Helicopters AS-350 B, C, D, D1, B1, B2, B3, BA &
EC-130 B4

Condenser/Evaporator

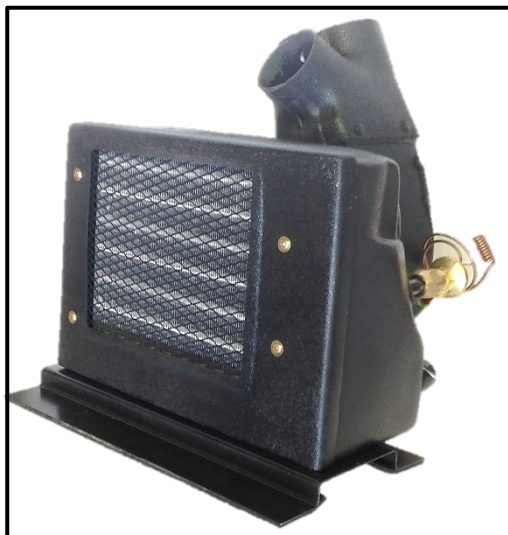

RSG PN: 560025-O-01

-02

**Fwd Evaporator
Assembly**

AS350 

Electrical Parts



RSG PN: 540009
**Electrical Box
Assembly**

EC130 



RSG PN: 540028-C-1-A
-C-2-A
**Electrical Box
Assembly**

AS350 



RSG PN: 540011-01
-02
**Instrument Panel
Switch**

EC130 



RSG PN: 540044-5
Harness Assembly

AS350 

Electrical Parts



RSG PN: 540044-8-01
-02

**Instrument Panel
Switch**

AS350 



RSG PN: 540044-9
**5 amp Breaker
Assembly**

AS350 

EC130 



RSG PN: 540089-01
-02

**Aft Evaporator Switch
Assembly**

AS350 

Electrical Parts



RSG PN: 050000
Switch with Button

AS350 

EC130 



RSG PN: 050001
Switch without Button

AS350 

EC130 



RSG PN: 050006
Switch without Button

AS350 



RSG PN: 050006-2
Switch with Button

AS350 

EC130 

Electrical Parts



RSG PN: 050007-1
Button



RSG PN: 050007-3
Button



RSG PN: 050007-4
Button



RSG PN: 050008
Relay



Electrical Parts

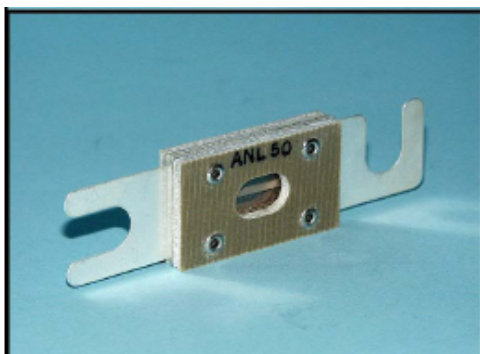

RSG PN: 050015-2
50 Amp Limiter

AS350 

EC130 



RSG PN: 050026
Timer

AS350 

EC130 



RSG PN: 050107
Low Pressure Switch

AS350 

EC130 



RSG PN: 090004
High Pressure Switch

AS350 

EC130 

Electrical Parts

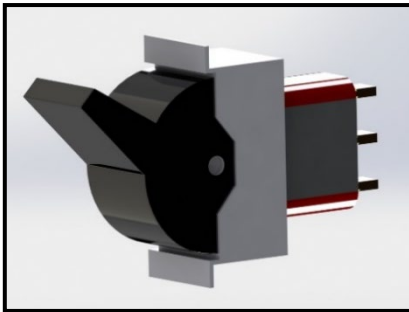

RSG PN: 7303J21ZQI22
Switch, 3PDT, 3 POS.

AS350 

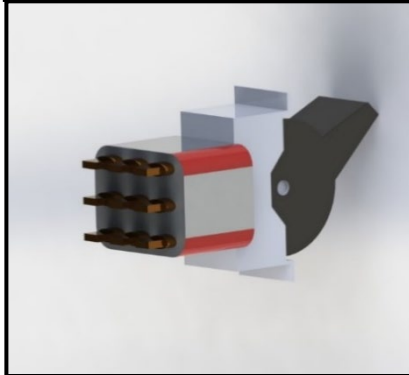

RSG PN: 7301J21ZGE22
Switch, 3PDT, 3 POS.

AS350 

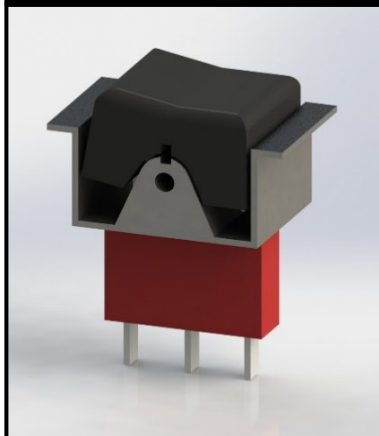

RSG PN: 7301J11ZQE22
Switch, SPST, 2 POS.

AS350 

Electrical Parts

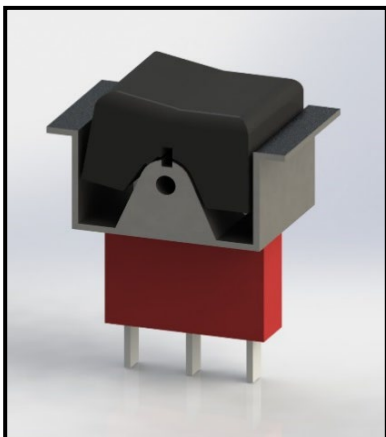

RSG PN: 7101J51ZQE22
Switch, SPST, 2 POS.

EC130 

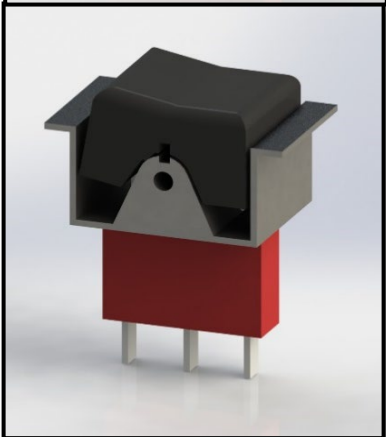

RSG PN: 7203J51ZQE22
Switch, DPDT, 2 POS.

EC130 

EC130 Hoses



RSG PN: 570103
**High Pressure Hose #6
Assembly**

EC130 



RSG PN: 570104
**Condenser to
Receiver/Drier Hose #6
Assembly**

EC130 



RSG PN: 570105
**Return Hose #10
Assembly**

EC130 

AS350 Hoses



RSG PN: 570067-O-A
Hose Assembly #6
Condenser to Drier

AS350 



RSG PN: 570070-O-A-01
Hose Assembly #8
Compressor Discharge

AS350 



RSG PN: 570070-O-A-02
Hose Assembly #8
Compressor Discharge

AS350 



RSG PN: 570020-O-A
Hose Assembly #6
Condenser to Drier

AS350 

AS350 Hoses



RSG PN: 570024-O-A-01
Hose Assembly #8
Compressor Discharge

AS350 



RSG PN: 570024-O-A-02
Hose Assembly #8
Compressor Discharge

AS350 



RSG PN: 570072-O-A
Hose Assembly #6 Fwd
Evaporator to Receiver/Drier

AS350 

AS350 Hoses



RSG PN: 570087-O-A-01
**Hose Assembly Fwd
Evaporator to Aft Evaporator
to Compressor**



RSG PN: 570087-O-A-02
**Hose Assembly Fwd
Evaporator to Aft Evaporator
to Compressor**



BRUSHLESS BLOWER MOTORS



RSG PN: IFSS 050084-7-2
**7" DC Brushless Blower
Assembly Short**

AS350 

EC130 



RSG PN: IFSS 050084-7-3
**7" DC Brushless Blower
Assembly Long**

AS350 

EC130 



TITLE:
Air Conditioning System Installation Instructions For Continued Airworthiness for Airbus Helicopters AS-350 B, C, D, D1, B1, B2, B3, BA & EC-130 B4

LIST OF CONSUMABLE MATERIALS

DESCRIPTION	P/N	VENDOR/SPECIFICATION
THREAD LOCK	242	LOCTITE
ADHESIVE	1300L	3M
Cleaning cloth, Low-Lint	--	Commercial
Mineral Spirits, Cleaning Solvent	--	MIL-PRF-680, TYP II OR ASTM-D235
Alodine	Alodine 1200	--
Alodine	Iridite 14-2	--
Paint Stripper	Turco 5873	--
Polyamide Paint Primer	--	--
Dye Penetrant Kit	--	--
Acetone	--	ASTM-D329
Isopropyl Alcohol	--	TT-I-735
Trichloroethane	--	MIL-T-81533
Nylon Scouring Pad	(3M) Scotchbrite 63	3M
240 Grit Sandpaper	--	Commercial
320 Grit Sandpaper	--	Commercial
240 Grit Aluminum Oxide Abrasive	--	Commercial
Cloth	--	Commercial
Sealant	--	MIL-S-8802
Adhesive transfer tape 950 (2")	70-0060-3057-4	3M
Refrigerant	R134a	--

Chapter 98

Section 98-00-00 Wiring Diagrams and Plumbing Schematics

This section contains all applicable wiring diagrams and plumbing schematics.

TITLE:
Air Conditioning System Installation Instructions For Continued Airworthiness for Airbus Helicopters AS-350 B, C, D, D1, B1, B2, B3, BA & EC-130 B4

REV.	DATE	DESCRIPTION OF CHANGE	APP'D BY	REV. BY
A	01/01/08	WAS PINK IN PINK. DELETED REMANENT OF ACTUAL ADDRESS		
B	01/01/08	BUMP PRESSURE WAS CHANGE TO BUMP. CHANGED LOCATION OF LOW PRESSURE SWITCH.		
C	01/01/08	REMOVED DRAWING NO. WAS 40558 042 02 E.		
D	01/01/08	CONVERTED TO AUTOCAD.		
E	01/01/08	REMOVED FOR CLARITY. REMOVED TTY BLOCK.	JTW	
F	08/07/14	REMOVED TTY BLOCK AND TYPING BLOCK. ADDED INTERCHANGEABLE FUSES AND INTERCHANGEABLE FUSE HOLDER FROM DRAWING # 208.	AJC	
G	01/01/2023	SHEET OF 1. WILL DIRECT ELECTRICAL BLOC WIRING DIAGRAM SHEET OF 2. WILL DIRECT GROUNDING DIAGRAM SHEET OF 3. WILL DIRECT PAN MOTOR AND MOTOR CONTROLLER REMOVED REMOVED OPTICAL FILTER FOR CONDENSER REMOVED INTERCHANGEABLE FUSE HOLDER REMOVED INTERCHANGEABLE FUSE HOLDER WILL BE PERFORMED ON AN INTERCHANGEABLE FUSE HOLDER. INTERCHANGEABLE FUSE HOLDER WILL BE PERFORMED ON AN INTERCHANGEABLE FUSE HOLDER. INTERCHANGEABLE FUSE HOLDER WILL BE PERFORMED ON AN INTERCHANGEABLE FUSE HOLDER. INTERCHANGEABLE FUSE HOLDER WILL BE PERFORMED ON AN INTERCHANGEABLE FUSE HOLDER.		

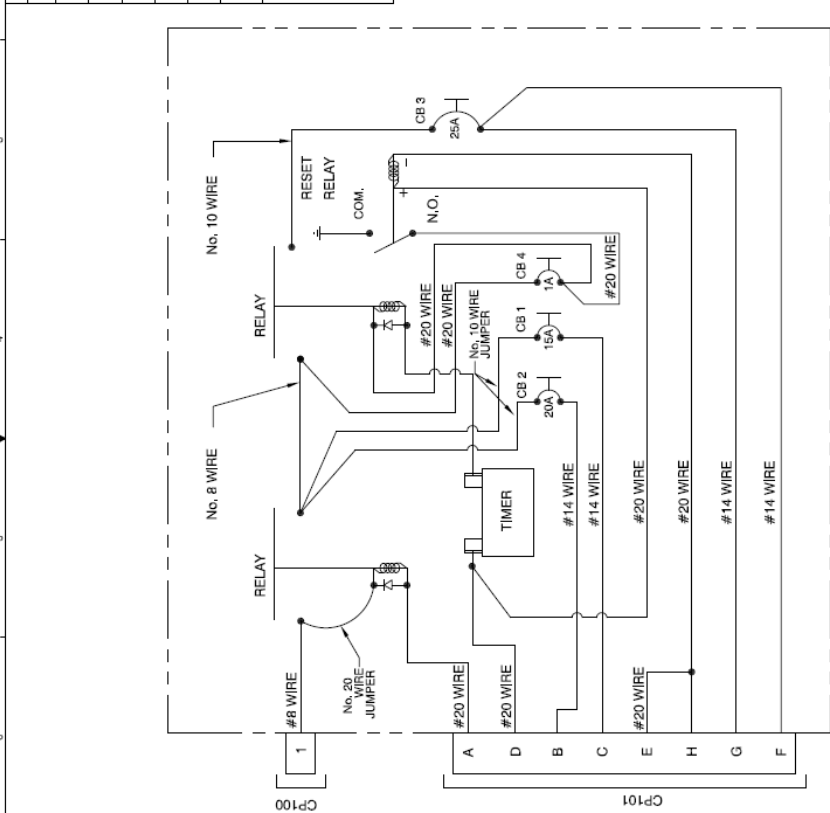

- NOTES:
- ALL WIRE MUST BE COLOR-CODED AND Labeled according to the drawings specified.
 - FUSES MAY BE USED (VPI) 1/200V/050 (30AMP).
 - LOCATE #8 WIRE AT T4, T6, OR T7. INSTALL BUMP PUMP IF NOT PRESENT. SEE NOTE 2).
 - WHEN ALL CONDENSER FUSES OR CIRCUIT BREAKERS ARE UTILIZED, A MAIN CURRENT JUMPER MUST BE INSTALLED BETWEEN THE MAIN CURRENT JUMPER AND THE MAIN CURRENT JUMPER. FOR EACH COMPONENT MAIN CURRENT JUMPER IS PROVIDED IN THE DRAWING. SEE DRAWING 2-21-MAS350 FOR MAIN CURRENT JUMPER. NUMBER 30AMP (RMS) CONDENSER FUSE WITH MODEL NUMBER 30AMP (RMS) MUST BE USED FOR EACH CONDENSER UNIT.
 - WIRING AND SUPPORT WIRING HARNESS MUST BE CONNECTED TO ONLY AVAILABLE FUSE POINTS AND SUPPORT WIRING HARNESS BAY ACALS-318, CHAPTER 11, SECTION A.
 - SECTION 9. HANGDOWN 11-145.
 - WIRING AND HARNESS TO BE REPARATED BAY ACALS-318, CHAPTER 11, SECTION A.
 - INSTALL SERVICE LOOP AT WIRING TERMINALS BAY ACALS-318, CHAPTER 11, SECTION 15.
 - TRANSFER TO THE WIRING AND BONDING BAY ACALS-318, CHAPTER 11, SECTION 15.
 - WIRING AND BONDING CONNECTIONS WITH PROPER HEATSHRINK tubing SIZE. HEATSHRINK TUBING TO BE SECURED WITH LACING CORD OR SMALL TIE WRAPS.
 - WIRING AND BONDING CONNECTIONS WITH PROPER HEATSHRINK tubing SIZE. HEATSHRINK TUBING TO BE SECURED WITH LACING CORD OR SMALL TIE WRAPS. TO THE CONSOLE THEN THE DRAWING WIRE MUST ALSO BE RELOCATED. RELOCATE WIRE TO THE CONSOLE. WIRING AND BONDING BAY ACALS-318, CHAPTER 11, SECTION 15.
 - WIRING AND BONDING CONNECTIONS WITH PROPER HEATSHRINK tubing SIZE. HEATSHRINK TUBING TO BE SECURED WITH LACING CORD OR SMALL TIE WRAPS. TO THE CONSOLE THEN THE DRAWING WIRE MUST ALSO BE RELOCATED. RELOCATE WIRE TO THE CONSOLE. WIRING AND BONDING BAY ACALS-318, CHAPTER 11, SECTION 15.
 - WIRING AND BONDING CONNECTIONS WITH PROPER HEATSHRINK tubing SIZE. HEATSHRINK TUBING TO BE SECURED WITH LACING CORD OR SMALL TIE WRAPS. TO THE CONSOLE THEN THE DRAWING WIRE MUST ALSO BE RELOCATED. RELOCATE WIRE TO THE CONSOLE. WIRING AND BONDING BAY ACALS-318, CHAPTER 11, SECTION 15.
 - WIRING AND BONDING CONNECTIONS WITH PROPER HEATSHRINK tubing SIZE. HEATSHRINK TUBING TO BE SECURED WITH LACING CORD OR SMALL TIE WRAPS. TO THE CONSOLE THEN THE DRAWING WIRE MUST ALSO BE RELOCATED. RELOCATE WIRE TO THE CONSOLE. WIRING AND BONDING BAY ACALS-318, CHAPTER 11, SECTION 15.

PROPRIETARY NOTICE THE OCCURRENCE AND INFORMATION OF TECHNICAL DATA TO BE KEPT STRICTLY CONFIDENTIAL AND NOT TO BE DISCLOSED TO ANY OTHER PARTY WITHOUT THE WRITTEN CONSENT AND AUTHORIZATION OF RSG PRODUCTS INC. ANY INFORMATION CONTAINED IN THIS DOCUMENT IS THE PROPERTY OF RSG PRODUCTS INC. AND IS NOT TO BE DISCLOSED OR REPRODUCED IN ANY MANNER WITHOUT THE WRITTEN CONSENT OF RSG PRODUCTS INC.	TOLERANCE EXCEPT AS SHOWN ALL DIMENSIONS ARE IN INCHES UNLESS OTHERWISE STATED. DATE: N/A	REV. G	DATE: 04/16/02	SCALE: N/A	SHEET: 1 OF 2
----------------------------------------------------------------------------------------------------------------------------------------------------------------------------------------------------------------------------------------------------------------------------------------------------------------------------------------------------------------------------------------------------------------------	--------------------------------------------------------------------------------------------------------	---------------	-----------------------	-------------------	----------------------

RSG PRODUCTS INC.
A ROTORCRAFT SERVICES GROUP COMPANY

ELECTRICAL DIAGRAM
DRAWN BY: MAH
APPLICATOR: ASS50

ASS50
ELECTRICAL WIRING DIAGRAM FOR SINGLE CONDENSER BLOWER B3 ADDED TO PREVIOUS APPROVALS (AEC BASIC)

TITLE:
Air Conditioning System Installation Instructions For Continued Airworthiness for Airbus Helicopters AS-350 B, C, D, D1, B1, B2, B3, BA & EC-130 B4

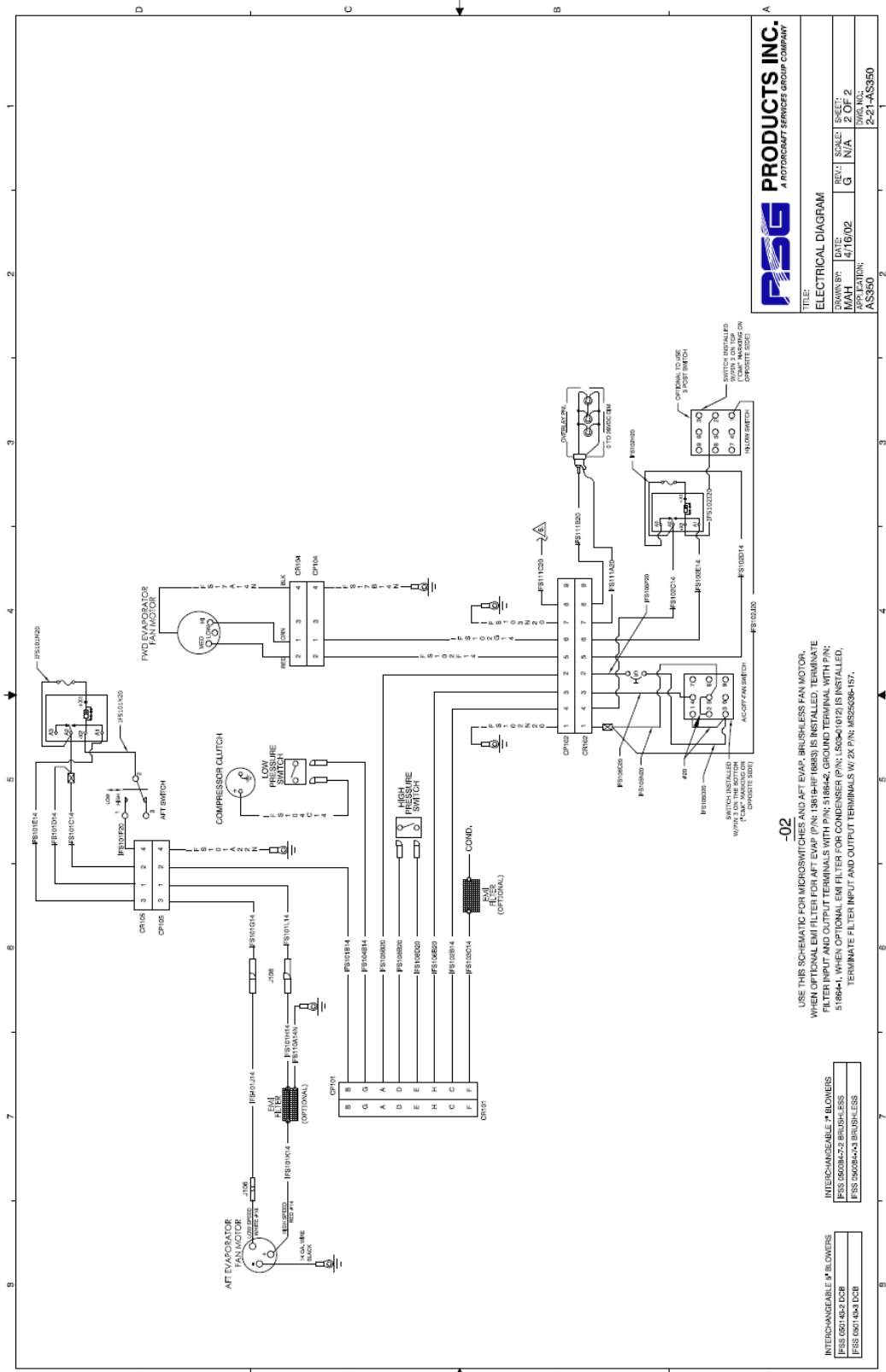

PSG PRODUCTS INC.
A ROTORCAFT SERVICES GROUP COMPANY

TITLE: ELECTRICAL DIAGRAM

DRAWN BY: MAH

DATE: 4/16/02

REV: G

SCALE: N/A

SHEET: 2 OF 2

APPROVAL: [Signature]

AS350P 2-21-AS350

-02

USE THIS SCHEMATIC FOR MICROSWITCHES AND AFT EVAP. BRUSHLESS FAN MOTOR. WHEN OPTIONAL EM FILTER FOR AFT EVAP (P/N: 18184P/18183) IS INSTALLED, TERMINATE FILTER INPUT AND OUTPUT TERMINALS WITH P/N: 5196A-2. GROUND TERMINAL WITH P/N: 5196A-1. WHEN OPTIONAL EM FILTER FOR CONDENSER (P/N: 15290/012) IS INSTALLED, TERMINATE FILTER INPUT AND OUTPUT TERMINALS W/ 2X P/N: MS25036-157.

INTERCHANGEABLE * BLOWERS
PSS 0001452 DCB
PSS 0001454 DCB

INTERCHANGEABLE * BLOWERS
PSS 0008272 BRUSHLESS
PSS 0008244-3 BRUSHLESS

TITLE: Air Conditioning System Installation Instructions For Continued Airworthiness for Airbus Helicopters AS-350 B, C, D, D1, B1, B2, B3, BA & EC-130 B4

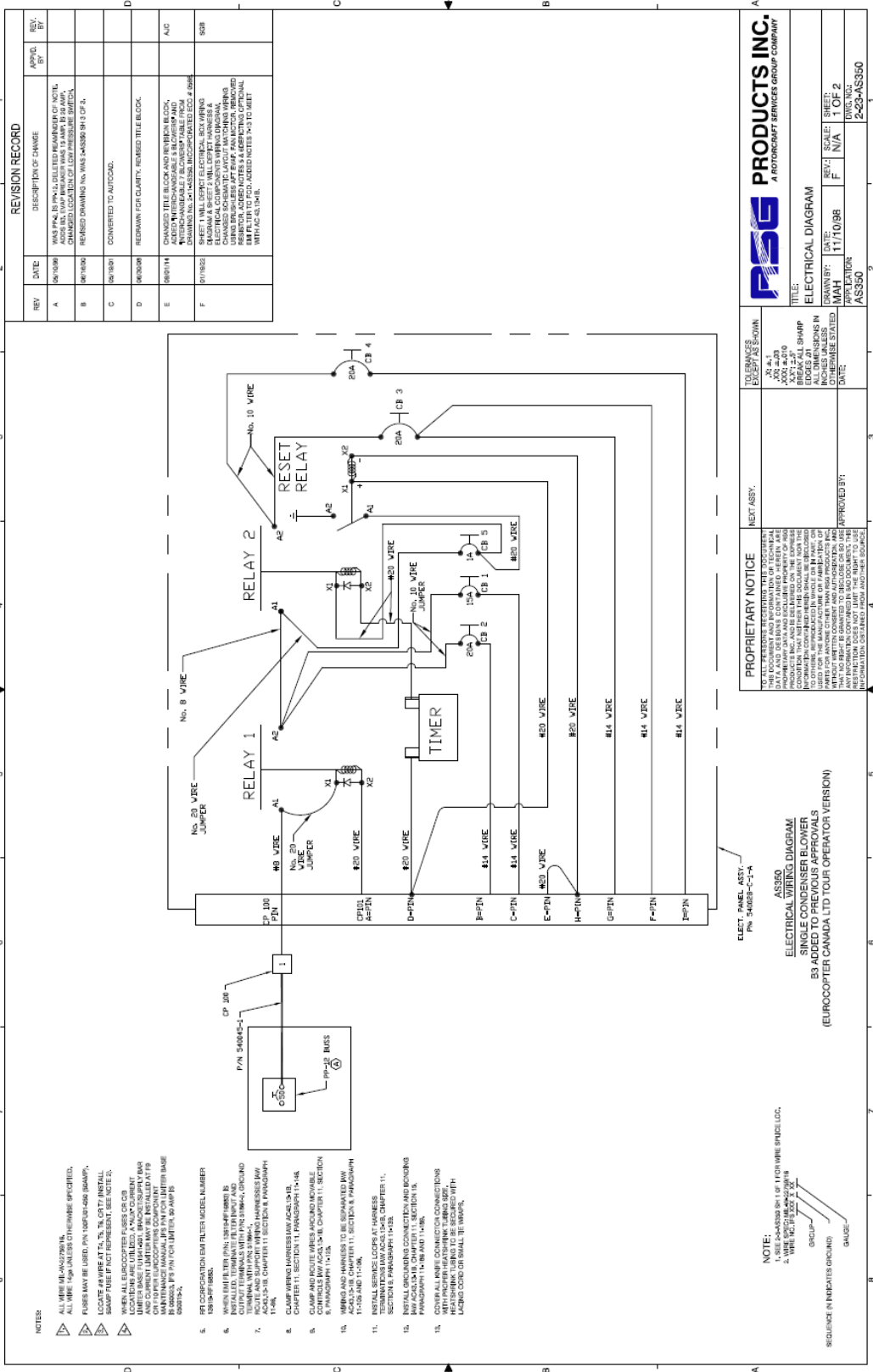

REV.	DATE	DESCRIPTION OF CHANGE	APPROV. BY	REV. BY
A	08/04/2023	WAS P/N 540045-1 REPLACED WITH P/N 540045-2. WIRE NO. 10 WAS ADDED TO WIRE NO. 10. WIRE NO. 10 WAS ADDED TO WIRE NO. 10.		
B	08/04/2023	REMOVED WIRE NO. 10. WIRE NO. 10 WAS ADDED TO WIRE NO. 10.		
C	08/04/2023	CONVERTED TO AUTO-CHECK.		
D	08/04/2023	REMOVED FOR CLARITY. REMOVED THE BLOCK.		
E	08/04/2023	CHANGED THE BLOCK AND REMOVED BLOCK. ADDED INTER-CONNECTABLE 5 WIRE AND 5 WIRE. ADDED INTER-CONNECTABLE 5 WIRE AND 5 WIRE. ADDED INTER-CONNECTABLE 5 WIRE AND 5 WIRE.	AJC	
F	01/10/2023	SHEET 1 WILL DISPLAY ELECTRICAL BOX WIRING DIAGRAM. SHEET 2 WILL DISPLAY ELECTRICAL BOX WIRING DIAGRAM. SHEET 3 WILL DISPLAY ELECTRICAL BOX WIRING DIAGRAM. SHEET 4 WILL DISPLAY ELECTRICAL BOX WIRING DIAGRAM. SHEET 5 WILL DISPLAY ELECTRICAL BOX WIRING DIAGRAM. SHEET 6 WILL DISPLAY ELECTRICAL BOX WIRING DIAGRAM. SHEET 7 WILL DISPLAY ELECTRICAL BOX WIRING DIAGRAM. SHEET 8 WILL DISPLAY ELECTRICAL BOX WIRING DIAGRAM. SHEET 9 WILL DISPLAY ELECTRICAL BOX WIRING DIAGRAM. SHEET 10 WILL DISPLAY ELECTRICAL BOX WIRING DIAGRAM. SHEET 11 WILL DISPLAY ELECTRICAL BOX WIRING DIAGRAM. SHEET 12 WILL DISPLAY ELECTRICAL BOX WIRING DIAGRAM. SHEET 13 WILL DISPLAY ELECTRICAL BOX WIRING DIAGRAM. SHEET 14 WILL DISPLAY ELECTRICAL BOX WIRING DIAGRAM. SHEET 15 WILL DISPLAY ELECTRICAL BOX WIRING DIAGRAM. SHEET 16 WILL DISPLAY ELECTRICAL BOX WIRING DIAGRAM. SHEET 17 WILL DISPLAY ELECTRICAL BOX WIRING DIAGRAM. SHEET 18 WILL DISPLAY ELECTRICAL BOX WIRING DIAGRAM. SHEET 19 WILL DISPLAY ELECTRICAL BOX WIRING DIAGRAM. SHEET 20 WILL DISPLAY ELECTRICAL BOX WIRING DIAGRAM. SHEET 21 WILL DISPLAY ELECTRICAL BOX WIRING DIAGRAM. SHEET 22 WILL DISPLAY ELECTRICAL BOX WIRING DIAGRAM. SHEET 23 WILL DISPLAY ELECTRICAL BOX WIRING DIAGRAM. SHEET 24 WILL DISPLAY ELECTRICAL BOX WIRING DIAGRAM. SHEET 25 WILL DISPLAY ELECTRICAL BOX WIRING DIAGRAM. SHEET 26 WILL DISPLAY ELECTRICAL BOX WIRING DIAGRAM. SHEET 27 WILL DISPLAY ELECTRICAL BOX WIRING DIAGRAM. SHEET 28 WILL DISPLAY ELECTRICAL BOX WIRING DIAGRAM. SHEET 29 WILL DISPLAY ELECTRICAL BOX WIRING DIAGRAM. SHEET 30 WILL DISPLAY ELECTRICAL BOX WIRING DIAGRAM. SHEET 31 WILL DISPLAY ELECTRICAL BOX WIRING DIAGRAM. SHEET 32 WILL DISPLAY ELECTRICAL BOX WIRING DIAGRAM. SHEET 33 WILL DISPLAY ELECTRICAL BOX WIRING DIAGRAM. SHEET 34 WILL DISPLAY ELECTRICAL BOX WIRING DIAGRAM. SHEET 35 WILL DISPLAY ELECTRICAL BOX WIRING DIAGRAM. SHEET 36 WILL DISPLAY ELECTRICAL BOX WIRING DIAGRAM. SHEET 37 WILL DISPLAY ELECTRICAL BOX WIRING DIAGRAM. SHEET 38 WILL DISPLAY ELECTRICAL BOX WIRING DIAGRAM. SHEET 39 WILL DISPLAY ELECTRICAL BOX WIRING DIAGRAM. SHEET 40 WILL DISPLAY ELECTRICAL BOX WIRING DIAGRAM. SHEET 41 WILL DISPLAY ELECTRICAL BOX WIRING DIAGRAM. SHEET 42 WILL DISPLAY ELECTRICAL BOX WIRING DIAGRAM. SHEET 43 WILL DISPLAY ELECTRICAL BOX WIRING DIAGRAM. SHEET 44 WILL DISPLAY ELECTRICAL BOX WIRING DIAGRAM. SHEET 45 WILL DISPLAY ELECTRICAL BOX WIRING DIAGRAM. SHEET 46 WILL DISPLAY ELECTRICAL BOX WIRING DIAGRAM. SHEET 47 WILL DISPLAY ELECTRICAL BOX WIRING DIAGRAM. SHEET 48 WILL DISPLAY ELECTRICAL BOX WIRING DIAGRAM. SHEET 49 WILL DISPLAY ELECTRICAL BOX WIRING DIAGRAM. SHEET 50 WILL DISPLAY ELECTRICAL BOX WIRING DIAGRAM. SHEET 51 WILL DISPLAY ELECTRICAL BOX WIRING DIAGRAM. SHEET 52 WILL DISPLAY ELECTRICAL BOX WIRING DIAGRAM. SHEET 53 WILL DISPLAY ELECTRICAL BOX WIRING DIAGRAM. SHEET 54 WILL DISPLAY ELECTRICAL BOX WIRING DIAGRAM. SHEET 55 WILL DISPLAY ELECTRICAL BOX WIRING DIAGRAM. SHEET 56 WILL DISPLAY ELECTRICAL BOX WIRING DIAGRAM. SHEET 57 WILL DISPLAY ELECTRICAL BOX WIRING DIAGRAM. SHEET 58 WILL DISPLAY ELECTRICAL BOX WIRING DIAGRAM. SHEET 59 WILL DISPLAY ELECTRICAL BOX WIRING DIAGRAM. SHEET 60 WILL DISPLAY ELECTRICAL BOX WIRING DIAGRAM. SHEET 61 WILL DISPLAY ELECTRICAL BOX WIRING DIAGRAM. SHEET 62 WILL DISPLAY ELECTRICAL BOX WIRING DIAGRAM. SHEET 63 WILL DISPLAY ELECTRICAL BOX WIRING DIAGRAM. SHEET 64 WILL DISPLAY ELECTRICAL BOX WIRING DIAGRAM. SHEET 65 WILL DISPLAY ELECTRICAL BOX WIRING DIAGRAM. SHEET 66 WILL DISPLAY ELECTRICAL BOX WIRING DIAGRAM. SHEET 67 WILL DISPLAY ELECTRICAL BOX WIRING DIAGRAM. SHEET 68 WILL DISPLAY ELECTRICAL BOX WIRING DIAGRAM. SHEET 69 WILL DISPLAY ELECTRICAL BOX WIRING DIAGRAM. SHEET 70 WILL DISPLAY ELECTRICAL BOX WIRING DIAGRAM. SHEET 71 WILL DISPLAY ELECTRICAL BOX WIRING DIAGRAM. SHEET 72 WILL DISPLAY ELECTRICAL BOX WIRING DIAGRAM. SHEET 73 WILL DISPLAY ELECTRICAL BOX WIRING DIAGRAM. SHEET 74 WILL DISPLAY ELECTRICAL BOX WIRING DIAGRAM. SHEET 75 WILL DISPLAY ELECTRICAL BOX WIRING DIAGRAM. SHEET 76 WILL DISPLAY ELECTRICAL BOX WIRING DIAGRAM. SHEET 77 WILL DISPLAY ELECTRICAL BOX WIRING DIAGRAM. SHEET 78 WILL DISPLAY ELECTRICAL BOX WIRING DIAGRAM. SHEET 79 WILL DISPLAY ELECTRICAL BOX WIRING DIAGRAM. SHEET 80 WILL DISPLAY ELECTRICAL BOX WIRING DIAGRAM. SHEET 81 WILL DISPLAY ELECTRICAL BOX WIRING DIAGRAM. SHEET 82 WILL DISPLAY ELECTRICAL BOX WIRING DIAGRAM. SHEET 83 WILL DISPLAY ELECTRICAL BOX WIRING DIAGRAM. SHEET 84 WILL DISPLAY ELECTRICAL BOX WIRING DIAGRAM. SHEET 85 WILL DISPLAY ELECTRICAL BOX WIRING DIAGRAM. SHEET 86 WILL DISPLAY ELECTRICAL BOX WIRING DIAGRAM. SHEET 87 WILL DISPLAY ELECTRICAL BOX WIRING DIAGRAM. SHEET 88 WILL DISPLAY ELECTRICAL BOX WIRING DIAGRAM. SHEET 89 WILL DISPLAY ELECTRICAL BOX WIRING DIAGRAM. SHEET 90 WILL DISPLAY ELECTRICAL BOX WIRING DIAGRAM. SHEET 91 WILL DISPLAY ELECTRICAL BOX WIRING DIAGRAM. SHEET 92 WILL DISPLAY ELECTRICAL BOX WIRING DIAGRAM. SHEET 93 WILL DISPLAY ELECTRICAL BOX WIRING DIAGRAM. SHEET 94 WILL DISPLAY ELECTRICAL BOX WIRING DIAGRAM. SHEET 95 WILL DISPLAY ELECTRICAL BOX WIRING DIAGRAM. SHEET 96 WILL DISPLAY ELECTRICAL BOX WIRING DIAGRAM. SHEET 97 WILL DISPLAY ELECTRICAL BOX WIRING DIAGRAM. SHEET 98 WILL DISPLAY ELECTRICAL BOX WIRING DIAGRAM. SHEET 99 WILL DISPLAY ELECTRICAL BOX WIRING DIAGRAM. SHEET 100 WILL DISPLAY ELECTRICAL BOX WIRING DIAGRAM.	808	

REVISION RECORD

PROPRIETARY NOTICE
 THIS DOCUMENT AND INFORMATION IS TECHNICAL IN NATURE AND IS THE PROPERTY OF RSG. IT IS TO BE USED ONLY FOR THE PURPOSES STATED HEREIN AND IS NOT TO BE REPRODUCED, COPIED, OR TRANSMITTED IN ANY FORM OR BY ANY MEANS, ELECTRONIC OR MECHANICAL, INCLUDING PHOTOCOPYING, RECORDING, OR BY ANY INFORMATION STORAGE AND RETRIEVAL SYSTEM. THE INFORMATION CONTAINED HEREIN IS NOT TO BE DISCLOSED TO ANY OTHER PARTY WITHOUT THE WRITTEN PERMISSION OF RSG. INFORMATION OBTAINED FROM OTHER SOURCES.

TO ERRORS
 AS SHOWN
 AS 2.1
 AS 2.0
 AS 1.0
 AS 0.1

REVISIONS
 BREAK ALL SHARP EDGES TO 0.031 INCHES UNLESS OTHERWISE STATED.

DATE

APPROVED BY:

DATE: 11/10/98

SCALE: N/A

SHEET: 1 OF 2

REV: F

REV. BY: N/A

REV. DATE: 11/10/98

APPLICATOR: ASS50

DWG. NO.: 243-MS350

PRODUCTS INC.
 A ROTORCRAFT SERVICES GROUP COMPANY

TITLE: ELECTRICAL DIAGRAM

DRAWN BY: MAH

DATE: 11/10/98

SCALE: N/A

SHEET: 1 OF 2

REV: F

REV. DATE: 11/10/98

APPLICATOR: ASS50

DWG. NO.: 243-MS350

NOTES:
 1. WIRE NO. 10 WAS ADDED TO WIRE NO. 10.
 2. WIRE NO. 10 WAS ADDED TO WIRE NO. 10.
 3. WIRE NO. 10 WAS ADDED TO WIRE NO. 10.
 4. WIRE NO. 10 WAS ADDED TO WIRE NO. 10.
 5. WIRE NO. 10 WAS ADDED TO WIRE NO. 10.
 6. WIRE NO. 10 WAS ADDED TO WIRE NO. 10.
 7. WIRE NO. 10 WAS ADDED TO WIRE NO. 10.
 8. WIRE NO. 10 WAS ADDED TO WIRE NO. 10.
 9. WIRE NO. 10 WAS ADDED TO WIRE NO. 10.
 10. WIRE NO. 10 WAS ADDED TO WIRE NO. 10.
 11. WIRE NO. 10 WAS ADDED TO WIRE NO. 10.
 12. WIRE NO. 10 WAS ADDED TO WIRE NO. 10.
 13. WIRE NO. 10 WAS ADDED TO WIRE NO. 10.
 14. WIRE NO. 10 WAS ADDED TO WIRE NO. 10.
 15. WIRE NO. 10 WAS ADDED TO WIRE NO. 10.
 16. WIRE NO. 10 WAS ADDED TO WIRE NO. 10.
 17. WIRE NO. 10 WAS ADDED TO WIRE NO. 10.
 18. WIRE NO. 10 WAS ADDED TO WIRE NO. 10.
 19. WIRE NO. 10 WAS ADDED TO WIRE NO. 10.
 20. WIRE NO. 10 WAS ADDED TO WIRE NO. 10.
 21. WIRE NO. 10 WAS ADDED TO WIRE NO. 10.
 22. WIRE NO. 10 WAS ADDED TO WIRE NO. 10.
 23. WIRE NO. 10 WAS ADDED TO WIRE NO. 10.
 24. WIRE NO. 10 WAS ADDED TO WIRE NO. 10.
 25. WIRE NO. 10 WAS ADDED TO WIRE NO. 10.
 26. WIRE NO. 10 WAS ADDED TO WIRE NO. 10.
 27. WIRE NO. 10 WAS ADDED TO WIRE NO. 10.
 28. WIRE NO. 10 WAS ADDED TO WIRE NO. 10.
 29. WIRE NO. 10 WAS ADDED TO WIRE NO. 10.
 30. WIRE NO. 10 WAS ADDED TO WIRE NO. 10.
 31. WIRE NO. 10 WAS ADDED TO WIRE NO. 10.
 32. WIRE NO. 10 WAS ADDED TO WIRE NO. 10.
 33. WIRE NO. 10 WAS ADDED TO WIRE NO. 10.
 34. WIRE NO. 10 WAS ADDED TO WIRE NO. 10.
 35. WIRE NO. 10 WAS ADDED TO WIRE NO. 10.
 36. WIRE NO. 10 WAS ADDED TO WIRE NO. 10.
 37. WIRE NO. 10 WAS ADDED TO WIRE NO. 10.
 38. WIRE NO. 10 WAS ADDED TO WIRE NO. 10.
 39. WIRE NO. 10 WAS ADDED TO WIRE NO. 10.
 40. WIRE NO. 10 WAS ADDED TO WIRE NO. 10.
 41. WIRE NO. 10 WAS ADDED TO WIRE NO. 10.
 42. WIRE NO. 10 WAS ADDED TO WIRE NO. 10.
 43. WIRE NO. 10 WAS ADDED TO WIRE NO. 10.
 44. WIRE NO. 10 WAS ADDED TO WIRE NO. 10.
 45. WIRE NO. 10 WAS ADDED TO WIRE NO. 10.
 46. WIRE NO. 10 WAS ADDED TO WIRE NO. 10.
 47. WIRE NO. 10 WAS ADDED TO WIRE NO. 10.
 48. WIRE NO. 10 WAS ADDED TO WIRE NO. 10.
 49. WIRE NO. 10 WAS ADDED TO WIRE NO. 10.
 50. WIRE NO. 10 WAS ADDED TO WIRE NO. 10.
 51. WIRE NO. 10 WAS ADDED TO WIRE NO. 10.
 52. WIRE NO. 10 WAS ADDED TO WIRE NO. 10.
 53. WIRE NO. 10 WAS ADDED TO WIRE NO. 10.
 54. WIRE NO. 10 WAS ADDED TO WIRE NO. 10.
 55. WIRE NO. 10 WAS ADDED TO WIRE NO. 10.
 56. WIRE NO. 10 WAS ADDED TO WIRE NO. 10.
 57. WIRE NO. 10 WAS ADDED TO WIRE NO. 10.
 58. WIRE NO. 10 WAS ADDED TO WIRE NO. 10.
 59. WIRE NO. 10 WAS ADDED TO WIRE NO. 10.
 60. WIRE NO. 10 WAS ADDED TO WIRE NO. 10.
 61. WIRE NO. 10 WAS ADDED TO WIRE NO. 10.
 62. WIRE NO. 10 WAS ADDED TO WIRE NO. 10.
 63. WIRE NO. 10 WAS ADDED TO WIRE NO. 10.
 64. WIRE NO. 10 WAS ADDED TO WIRE NO. 10.
 65. WIRE NO. 10 WAS ADDED TO WIRE NO. 10.
 66. WIRE NO. 10 WAS ADDED TO WIRE NO. 10.
 67. WIRE NO. 10 WAS ADDED TO WIRE NO. 10.
 68. WIRE NO. 10 WAS ADDED TO WIRE NO. 10.
 69. WIRE NO. 10 WAS ADDED TO WIRE NO. 10.
 70. WIRE NO. 10 WAS ADDED TO WIRE NO. 10.
 71. WIRE NO. 10 WAS ADDED TO WIRE NO. 10.
 72. WIRE NO. 10 WAS ADDED TO WIRE NO. 10.
 73. WIRE NO. 10 WAS ADDED TO WIRE NO. 10.
 74. WIRE NO. 10 WAS ADDED TO WIRE NO. 10.
 75. WIRE NO. 10 WAS ADDED TO WIRE NO. 10.
 76. WIRE NO. 10 WAS ADDED TO WIRE NO. 10.
 77. WIRE NO. 10 WAS ADDED TO WIRE NO. 10.
 78. WIRE NO. 10 WAS ADDED TO WIRE NO. 10.
 79. WIRE NO. 10 WAS ADDED TO WIRE NO. 10.
 80. WIRE NO. 10 WAS ADDED TO WIRE NO. 10.
 81. WIRE NO. 10 WAS ADDED TO WIRE NO. 10.
 82. WIRE NO. 10 WAS ADDED TO WIRE NO. 10.
 83. WIRE NO. 10 WAS ADDED TO WIRE NO. 10.
 84. WIRE NO. 10 WAS ADDED TO WIRE NO. 10.
 85. WIRE NO. 10 WAS ADDED TO WIRE NO. 10.
 86. WIRE NO. 10 WAS ADDED TO WIRE NO. 10.
 87. WIRE NO. 10 WAS ADDED TO WIRE NO. 10.
 88. WIRE NO. 10 WAS ADDED TO WIRE NO. 10.
 89. WIRE NO. 10 WAS ADDED TO WIRE NO. 10.
 90. WIRE NO. 10 WAS ADDED TO WIRE NO. 10.
 91. WIRE NO. 10 WAS ADDED TO WIRE NO. 10.
 92. WIRE NO. 10 WAS ADDED TO WIRE NO. 10.
 93. WIRE NO. 10 WAS ADDED TO WIRE NO. 10.
 94. WIRE NO. 10 WAS ADDED TO WIRE NO. 10.
 95. WIRE NO. 10 WAS ADDED TO WIRE NO. 10.
 96. WIRE NO. 10 WAS ADDED TO WIRE NO. 10.
 97. WIRE NO. 10 WAS ADDED TO WIRE NO. 10.
 98. WIRE NO. 10 WAS ADDED TO WIRE NO. 10.
 99. WIRE NO. 10 WAS ADDED TO WIRE NO. 10.
 100. WIRE NO. 10 WAS ADDED TO WIRE NO. 10.

TITLE:
Air Conditioning System Installation Instructions For Continued Airworthiness for Airbus Helicopters AS-350 B, C, D, D1, B1, B2, B3, BA & EC-130 B4

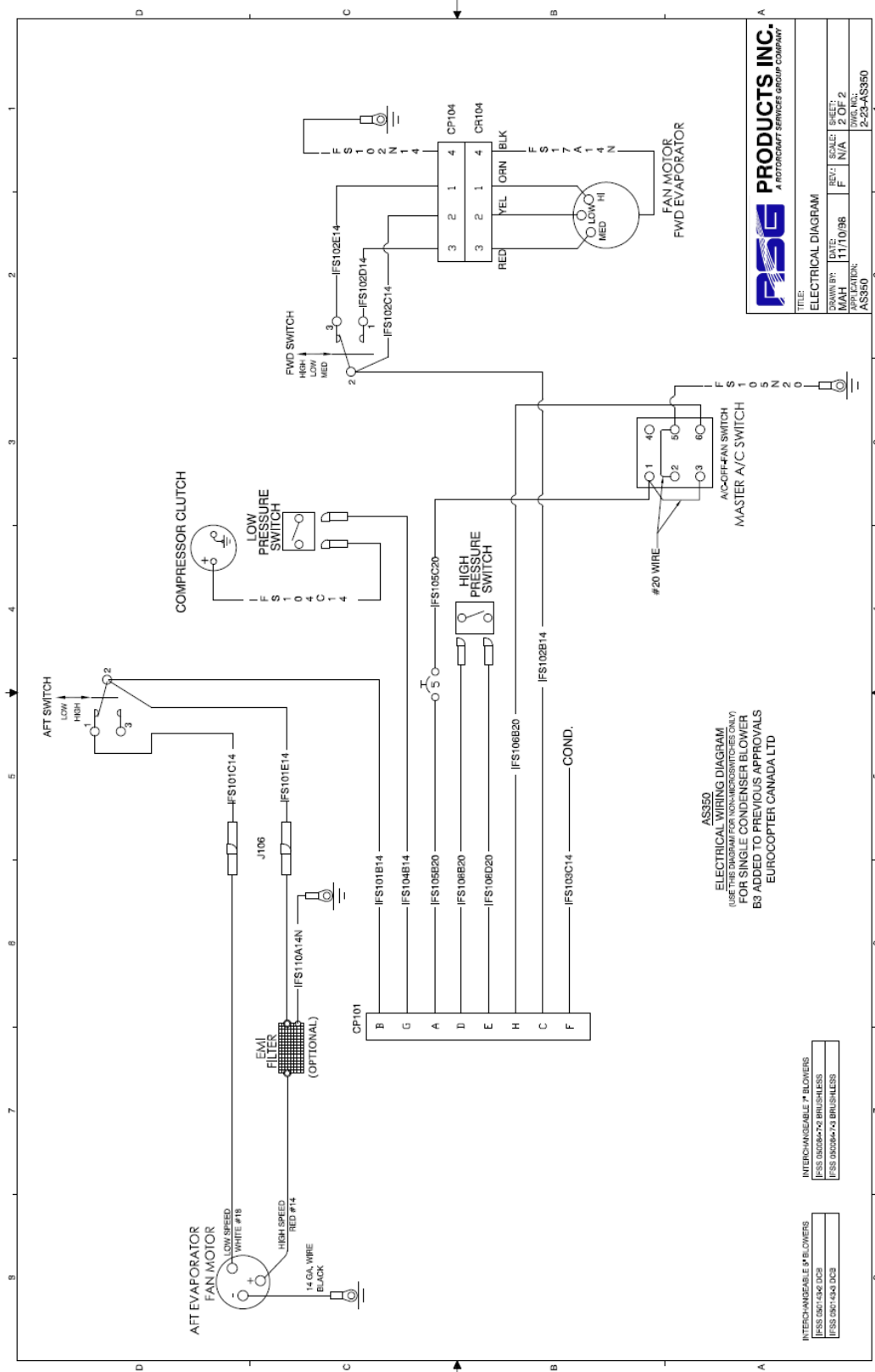

RSG PRODUCTS INC.
A ROTORCRAFT SERVICE GROUP COMPANY

TITLE: ELECTRICAL DIAGRAM
DRAWN BY: DATE: 11/10/98
MAH: REV: SCALE: N/A
REV: 2 OF 2
PART NO.: 2-23-ASS90

TITLE: Air Conditioning System Installation Instructions For Continued Airworthiness for Airbus Helicopters AS-350 B, C, D, D1, B1, B2, B3, BA & EC-130 B4

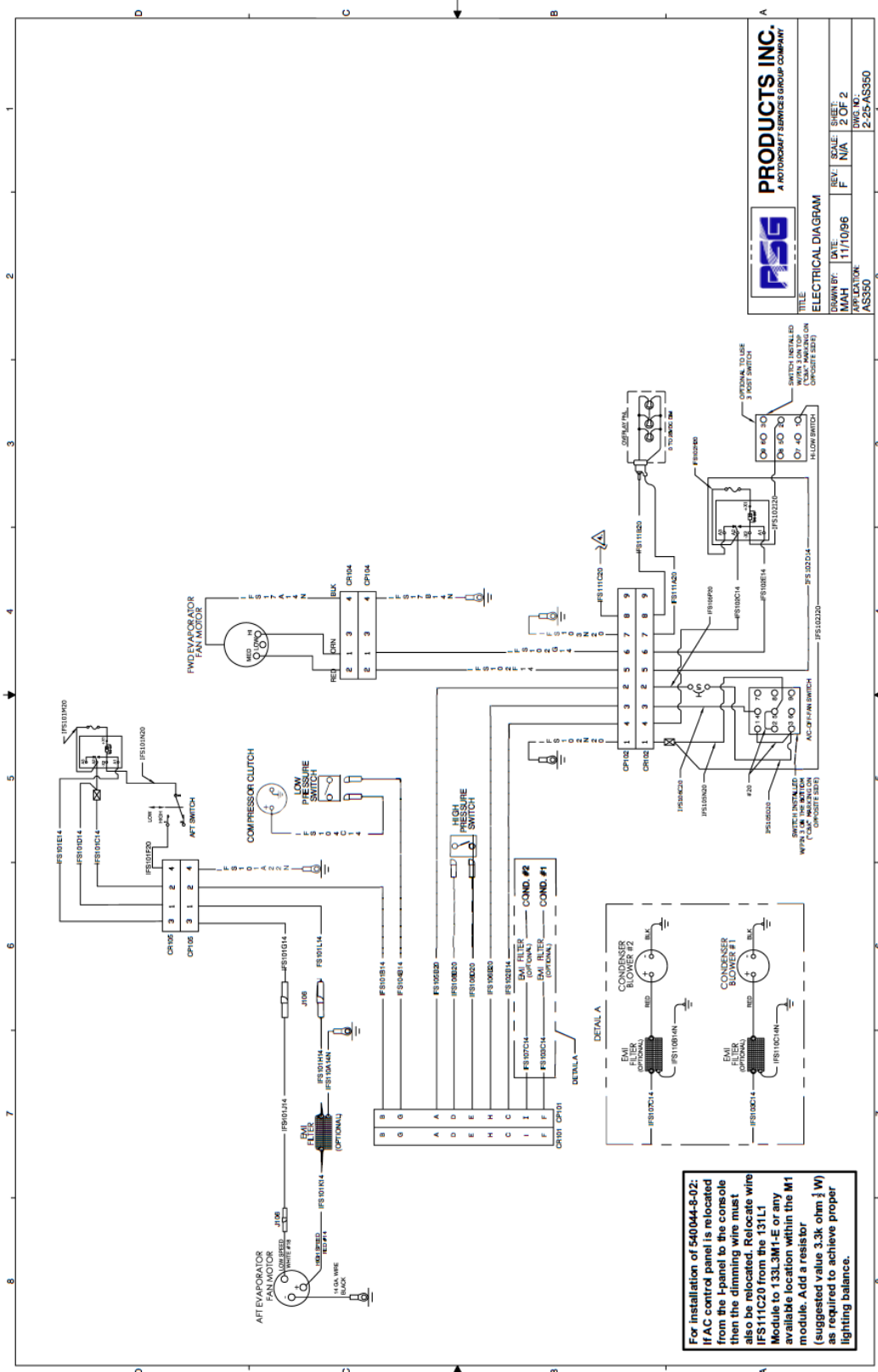

PSG PRODUCTS INC.
A ROTORCRAFT SERVICES GROUP COMPANY

TITLE: ELECTRICAL DIAGRAM

DRAWN BY: MAH	DATE: 11/10/96	REV: F	SCALE: N/A	SHEET: 2 OF 2
DESIGNED BY: AS350				2-254/AS350

For installation of 540044-8-02: If AC control panel is relocated from the I-panel to the console then the dimming wire must also be relocated. Relocate wire IFS111C20 from the 131L1 Module to 133L3M1-E or any available location within the M1 module. Add a resistor (suggested value 3.3k ohm $\frac{1}{2}$ W) as required to achieve proper lighting balance.

TITLE: Air Conditioning System Installation Instructions For Continued Airworthiness for Airbus Helicopters AS-350 B, C, D, D1, B1, B2, B3, BA & EC-130 B4

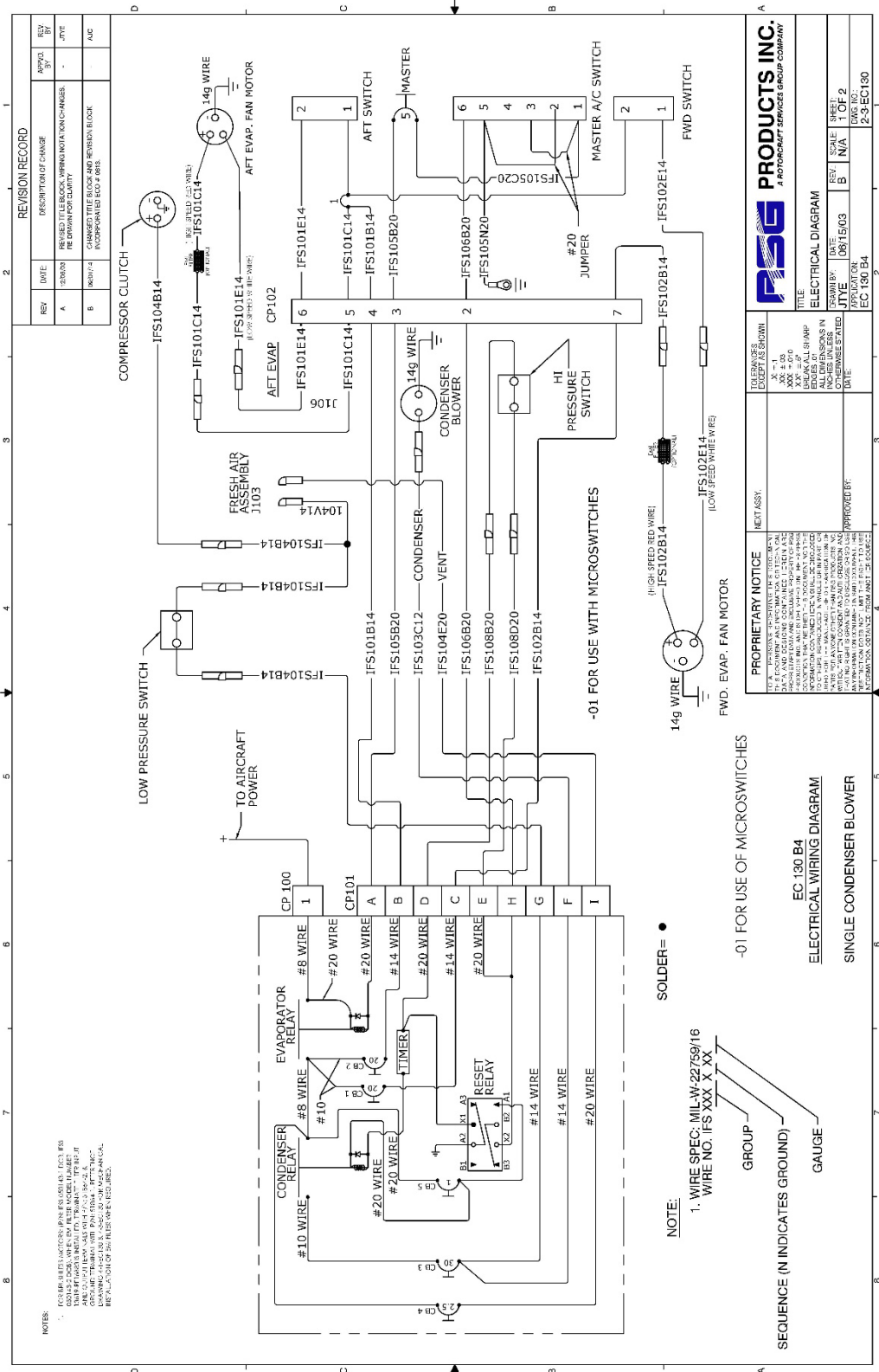

TITLE:
Air Conditioning System Installation Instructions For Continued Airworthiness for Airbus Helicopters AS-350 B, C, D, D1, B1, B2, B3, BA & EC-130 B4

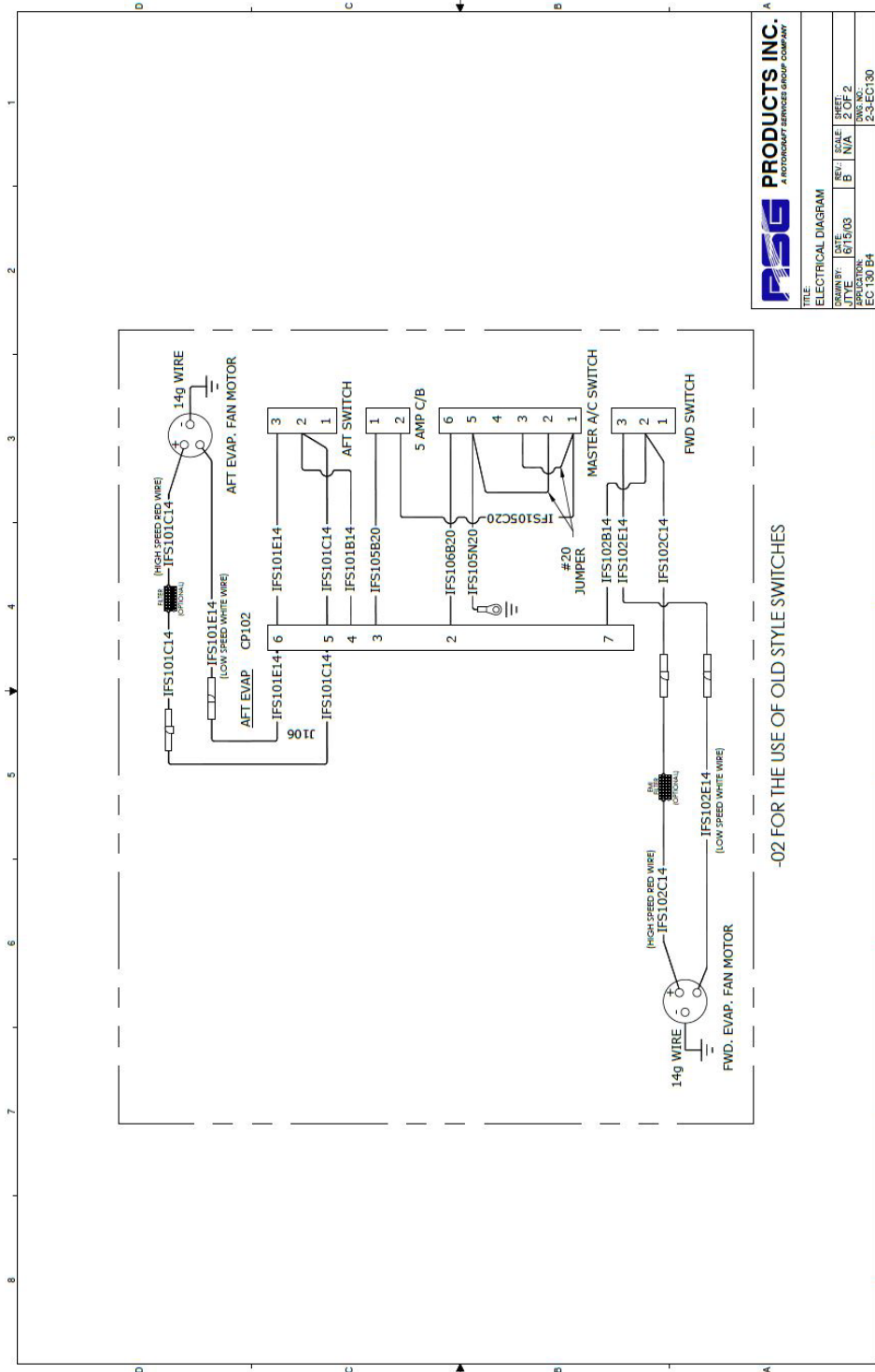

RSG PRODUCTS INC. A ROTORHUB AIRSERVICES GROUP COMPANY	
TITLE: ELECTRICAL DIAGRAM	
DESIGNED BY: B115/03	REV: N/A
APPROVED BY: B115/03	REV: 2 OF 2
APPLICATION: EC-130 B4	DATE: 2-3-EC-130
	2

TITLE: Air Conditioning System Installation Instructions For Continued Airworthiness for Airbus Helicopters AS-350 B, C, D, D1, B1, B2, B3, BA & EC-130 B4

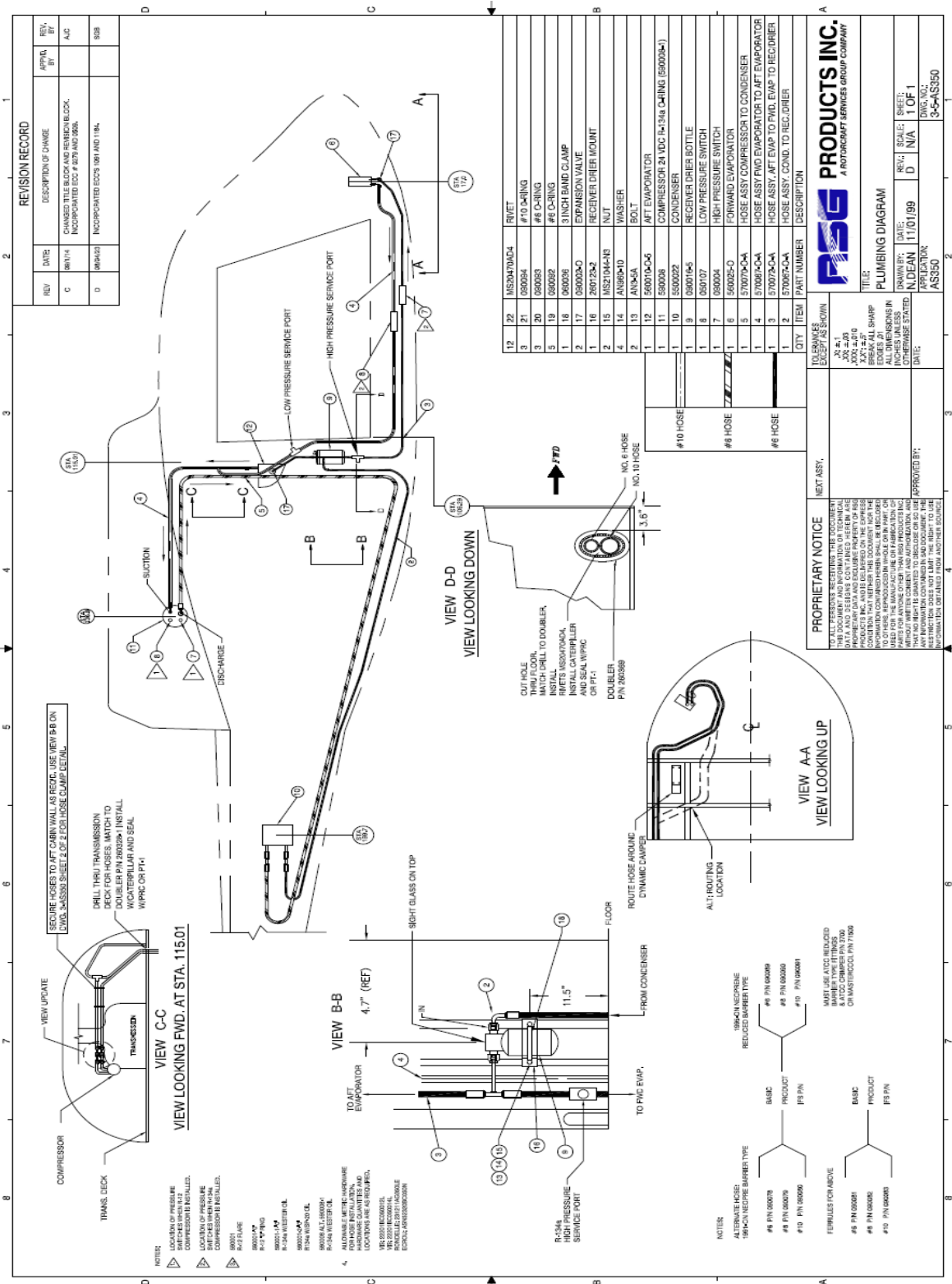

TITLE: Air Conditioning System Installation Instructions For Continued Airworthiness for Airbus Helicopters AS-350 B, C, D, D1, B1, B2, B3, BA & EC-130 B4

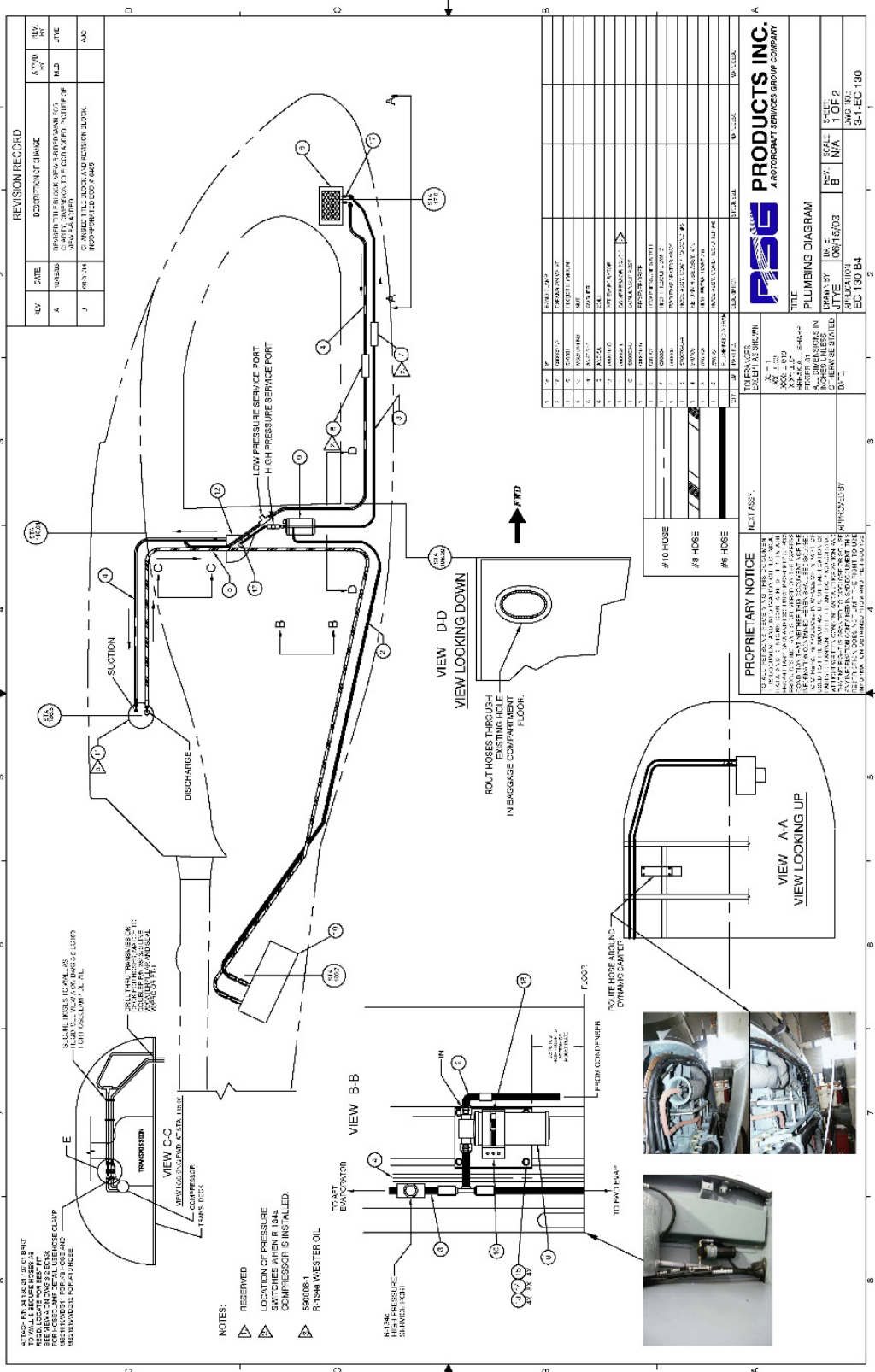

REVISION RECORD

REV.	DATE	DESCRIPTION/CHANGE	APP'D BY	REV. BY
A	08/04/2023	ISSUED FOR PRODUCTION	JTC	JTC
J	08/04/2023	REVISION 1000	JTC	JTC

NO.	DESCRIPTION	QTY	UNIT
1	COMPRESSOR	1	EA
2	CONDENSER	1	EA
3	EVAPORATOR	1	EA
4	EXPANSION VALVE	1	EA
5	PIPE	10	FT
6	HOSE	10	FT
7	ELBOW	10	EA
8	FLANGE	10	EA
9	VALVE	10	EA
10	CONNECTOR	10	EA

PROPRIETARY NOTICE

ALL RIGHTS RESERVED. THIS DOCUMENT IS THE PROPERTY OF RSG PRODUCTS INC. AND IS NOT TO BE REPRODUCED OR TRANSMITTED IN ANY FORM OR BY ANY MEANS, ELECTRONIC OR MECHANICAL, INCLUDING PHOTOCOPYING, RECORDING, OR BY ANY INFORMATION STORAGE AND RETRIEVAL SYSTEM, WITHOUT THE WRITTEN PERMISSION OF RSG PRODUCTS INC.

RSG PRODUCTS INC.
A ROTORCRAFT SERVICES GROUP COMPANY

TITLE: PLUMBING DIAGRAM
DRAWN BY: JTC
CHECKED BY: JTC
DATE: 08/04/2023

SCALE: 1 OF 2
REV: B
SHEET: 31-EC-130



DATE: 08/04/2023	DOC No.: IFSE-0007	REV: F-1	PAGE: 96 of 99
---------------------	-----------------------	-------------	-------------------

TITLE:
Air Conditioning System Installation Instructions For Continued
Airworthiness for Airbus Helicopters AS-350 B, C, D, D1, B1, B2, B3, BA &
EC-130 B4

APPENDIX A Weight and Balance

PERTAINS TO KIT #350-00-011
Weight (#) X Arm (") = Moment ("#)

ITEM	WEIGHT (#)	ARM (")	MOMENT ("#)
Forward Evaporator Assembly	13.50	19.00	256.50
Forward Air Outlets	.50	31.32	15.66
Aft Evaporator and Return Air	11.50	120.00	1380.00
Aft Evaporator Blower	5.00	120.85	604.25
Condenser Coil and Mount	19.50	133.80	2609.10
Condenser Blower and Mount	14.00	148.60	2080.40
Compressor and Mount	17.00	147.80	2512.60
Electrical Relay Panes	4.0	153.70	614.80
Refrigerant, Hoses and Fittings	7.50	76.90	576.75
<hr/>			
Sub Total: (Air Conditioner)	92.5		10650.06



DATE:
08/04/2023

DOC No.:
IFSE-0007

REV:
F-1

PAGE:
97 of 99

TITLE:
Air Conditioning System Installation Instructions For Continued
Airworthiness for Airbus Helicopters AS-350 B, C, D, D1, B1, B2, B3, BA &
EC-130 B4

PERTAINS TO KIT #350-00-031
Weight (#) X Arm (") = Moment ("#)

ITEM	WEIGHT (#)	ARM (")	MOMENT ("#)
Forward Evaporator Assembly	13.50	19.00	256.50
Forward Air Outlets	.50	31.32	15.66
Aft Evaporator and Return Air	11.50	120.00	1380.00
Aft Evaporator Blower	5.00	120.85	604.25
Condenser Assy. & Mount w/ Dual condenser blowers and closeout panel	40.00	201.80	8072.00
Compressor and Mount	17.00	147.80	2512.60
Electrical Relay Panes	4.0	153.70	614.80
Refrigerant, Hoses and Fittings	7.50	76.90	576.75
Sub Total: (Air Conditioner)	99.00		14032.56



DATE: 08/04/2023	DOC No.: IFSE-0007	REV: F-1	PAGE: 98 of 99
---------------------	-----------------------	-------------	-------------------

TITLE:
Air Conditioning System Installation Instructions For Continued
Airworthiness for Airbus Helicopters AS-350 B, C, D, D1, B1, B2, B3, BA &
EC-130 B4

PERTAINS TO KIT # 130-00-031
Weight (#) X Arm (") = Moment ("#)

ITEM	WEIGHT (#)	ARM (")	MOMENT ("#)
FWD. EVAP ASSY W/ MOTOR	14.0	24.0	336
FWD AIR OUTLETS (x2) W/ DUCTING	3.0	33.29	99.87
AFT EVAP W/ MOTOR & DUCTS	16.0	120.5	1928
CONDENSER ASSY W/ MOTOR & AIR DISCHARGE	33.0	223.3	7368.9
COMPRESSOR W/ MOUNTING KIT	17.5	147.8	2586.5
ELECTRICAL CONTROL BOX	4.0	153.7	614.8
REFRIGERANT HOSES	5.0	76.9	384.5
ELECTRICAL HARNESS	3.5	70.0	245
INSTALLATION TOTALS	96.0		13563.57

Step 13

Parts Break Down

PARTS LIST (PARTIAL)

IN

ALL AS350 SERIES

FOR

KIT # 350-00-031-HP

with

**AFT MOUNTED CONDENSER
(DUAL CONDENSER BLOWERS)**

"ESTER OIL EQUIPPED COMPRESSOR" Model: SD-507

Revised: August 19, 2022

May 22, 2015

November 4, 2009

August 28, 2006

February 1, 2002

March 1, 2001

August 6, 2001

MASTER PARTS LIST

AS350 SERIES

08/19/22

KIT #350-00-031HP

<u>ITEM</u>	<u>DESCRIPTION</u>	<u>PART #</u>
1.	BELT - FLAT	060018-1 060018 (Alt)
	BELT - GROOVED	060005
2.	SD-507 COMPRESSOR ASSEMBLY COMPLETE W/ FLAT PULLEY, 24 VDC COIL (FOR USE WITH R-134a ONLY, "ESTER oil equipped)	590008
	SD-507 COMPRESSOR ASSEMBLY COMPLETE W/ GROOVED PULLEY, 24 VDC COIL (FOR USE WITH R-134a ONLY, "ESTER oil equipped)	590008-1

COMPRESSOR PARTS

FOR: SD-507 W/ 5.0" CLUTCH

3.	24 VDC COIL (GREEN WIRE)	050033
----	---------------------------------	--------

COMPRESSOR PARTS

<u>ITEM</u>	<u>DESCRIPTION</u>	<u>PART #</u>
4.	5" VANE AXIAL BLOWER ASSY. (SINGLE FLANGE W/NYLON BLADE) For: AFT EVAPORATOR BLOWER ASSY. P/N 490017-1-02	IFSS 050143-2 DCB
5.	MOTOR, FORWARD EVAPORATOR 24VDC, single shaft, right hand	050052-1
6.	WHEEL, FORWARD EVAPORATOR, fan, metal, CC rotation, 5/16" bore	040004-8

CONDENSER BLOWER PARTS

7.	7" DC BRUSHLESS BLOWER ASSY.(Short Housing)	IFSS 050084-7-2
8.	7" DC BRUSHLESS BLOWER ASSY.(Long Housing)	IFSS 050084-7-3

RSG Products Inc.
Parts Break Down – 350-00-031 Air Conditioning

<u>ITEM</u>	<u>DESCRIPTION</u>	<u>PART #</u>
9.	RECEIVER/DRIER 1991 & ON – “O” RING TYPE	090016-5
10.	EXPANSION VALVE 1991 & ON – FWD. AND AFT EVAP. “O” RING TYPE	090002-“O”
11.	HIGH PRESSURE SAFETY SWITCH (ALL YEARS)	090004
12.	LOW PRESSURE SAFETY SWITCH 1991 & ON - NON-ADJUSTABLE (7 OUT/22 IN)	050107

**Reference Illustrated Parts List section 21-10-00 in ICA
for additional replacement parts**

RSG Products Inc.

Pressure Switch Identification

for all

vapor cycle air conditioning kits

using R-134a

Low Pressure Switch: P/N 050107

Leads are: **BLUE** in color

Mfg. P/N on switch: 20PS003MA022C007C

Opens: 7PSI Closes: 22 PSI

High Pressure Switch: P/N 090004

Leads are: **BLACK** in color

Mfg. P/N on switch: 20PS002MB375K265K

Opens: 375 PSI Closes: 265 PSI

ALT. Mfg. P/N on switch: 20PS104MB350K250K

Opens: 350 PSI Closes: 250 PSI

P/N 090004 (Both Types)

Step 14

T&C/Warranty/RMA



Standard Terms and Conditions of Sale

1. Terms of Payment: Unless prior arrangements are made to establish credit terms RSG Products Inc., all sales are prepaid in full prior to shipment. Payment may be made via cash, check or electronic transfer to RSG Products Inc. prior to delivery.

2. Buyer's Deposit: A 50% deposit is required to process an order for an air conditioning kit. The deposit is non-refundable and will be applied to the final price of the kit.

3. Taxes / Other Charges: Prices of the specified products are exclusive of all city, state, federal and international taxes, duties, levies or charges of any kind, including, without limitation, taxes on manufacture, sales, receipts, gross income, occupation, use and similar taxes or other charges. Whenever applicable, any taxes or other charges shall be added to the invoice as a separate charge to be paid by Buyer.

4. Shipment and Packaging: All products will be suitably packed, marked and shipped F.O.B. RSG Products Inc. Fort Worth Texas, in accordance with standard packaging procedures.

5. Delays: RSG Products Inc. will not be liable for any delay in the performance of orders or contracts, or in the delivery or shipment of goods, or for any damages suffered by Buyer by reason of such delays.

6. Technical Advice: RSG Products Inc. technical support staff is available for telephone consultation concerning the products it manufactures; however, RSG Products does not warrant or guarantee such advice.

7. Aircraft Variation: Due to aircraft manufacturing variations, alterations and other factors, there are differences between aircraft of a certain make and model. Because of these variations, RSG Products Inc. does not guarantee that Buyer has purchased the correct product or that a specified product will fit the intended aircraft. Further, RSG Products does not guarantee the number of labor hours required to install its products.

8. Returns: All sales are final unless a return is approved at the sole discretion of RSG Products Inc. If RSG Products Inc. does agree to accept a return, **25% restocking fee will be charged for all parts returned.** If RSG Products Inc. does agree to accept a return, **50% restocking fee will be charged for all AC Kits returned. All items returned to RSG Products Inc. must be sent freight prepaid and must have a return material authorization (RMA) number clearly marked on the shipping container.**

9. No Fault Found: If items are sent to RSG Products Inc. for evaluation and no problem is found, or if Buyer elects not to make the required repairs, then Buyer shall be responsible for the payment of **\$300 evaluation fee.**

10. Certificate of Conformity: RSG Products Inc. will provide a Certificate of Conformity with each product assuring that the product has been manufactured according to its approved design drawings. Any additional assurances or certifications shall be at the expense of Buyer and shall be added to the invoice as a separate charge to be paid by Buyer.

11. Failed Products: Should any product prove defective, RSG Products Inc. will either replace the item or adjust the matter fairly and promptly, but under no circumstances shall RSG Products be liable for consequential or other damages, losses, or expenses in connections with or by reason of the use or liability to use products purchased for any purpose.

12. Patents: Buyer shall hold RSG Products Inc. harmless from, and release and not make claim or suit against RSG Products because of any suits, claims, losses, or other liability made against, or suffered by, Buyer arising from any claim of, or infringement of, patent, copyright, trademark, or other proprietary right, at common law, or claim of unfair trade or of unfair competition, resulting from, or occasioned by Buyer's use, possession, sale, or delivery of the products sold to Buyer by RSG Products Inc.

13. Warranty Registration and Claims: The terms RSG Products Inc. Limited Warranty is written on the Warranty Registration Card and published on the Rotorcraft Service Group, website www.rotorcraftservices.com. The registration form must be completed and returned to RSG Products Inc. within 1 month of receipt of a product. Failure to complete the Warranty Registration Card may result in denial of a claim. In order to process a warranty claim, complete the Warranty Claim Form found under Customer Support on our website and e-mail to info@rotorcraftservices.com or fax to +1 817 624 6603, or call RSG Products Inc. at +1 817-624 6600. A Warranty Claim without a Return Material Authorization (RMA) Number will cause delays and a possible denial of the claim.



WEBSITE

Terms of Use. When you access, browse or use this Site, you accept, without limitation or qualification, the terms and conditions set forth below. If you do not agree to them, do not use the Site or download any materials from rotorcraftservices.com (formerly integratedflightsys.com). The information herein contained may include technical inaccuracies or typographical errors. Changes may periodically be made to the information and will be incorporated in new editions of this document without notice. In no event will RSG Products Inc. be liable to any party for any direct, indirect, special or other consequential damages for any use of this web site or any other hyper linked site; including without limitation any lost profits, business interruption, loss of programs or other data on your information handling system.

Site Information. Site information regarding RSG Products Inc., services, technical parts and components, including their availability, appearance, price and specifications are subject to change without notice. In no event shall RSG Products be held liable for indirect or consequential damages or any damages resulting from the use of information from this Site. The information on this Site is at the recipient's own risk.

Links. This site contains links to other Sites on the World Wide Web. RSG Products Inc. provides such links for your convenience only, and is not responsible for the content of any Site linked to or from this Site. Links from this Site to any other Site does not mean that RSG Products Inc. approves of, endorses or recommends that Site.

Rights of Use. Any person is hereby authorized to view, copy, print, and distribute any document published by Integrated Flight Systems Corp/RSG Products Inc. provided that it is: for personal use, for information purposes and reference must be made to RSG Products Inc. when the document is used.

Information Collected. When you visit this site, RSG Products Inc. may collect information in two ways – through information automatically gathered from your computer or through information you voluntarily provide. As to automatically gathered information, RSG Products collects navigational information about where visitors go on our Site, how many visits are made to the Site, when the Site is visited and other non-personally identifiable information (for example, this can include domain type, browser version, service provider, IP address). The navigational information that is automatically gathered when you visit rotorcraftservices.com is used on an aggregate basis to evaluate and effectiveness of our Site, to analyze trends and to administer the Site. This navigational information allows us to determine such things as which areas are most visited and difficulties our visitors may experience in accessing our Site. Voluntarily provided information is collected online if you elect to e-mail RSG Products Inc. Whenever this act is made the information you voluntarily provide, name, e-mail address, phone number, specific information comments or questions, is not distributed and is confidential. All information collected from our site and/or information voluntarily provided is kept confidential and is not distributed for any reason without your approval.

14. Acceptance: This is not a firm offer and may be changed or revoked at any time. Acceptance of this offer is expressly limited to the exact terms contained herein, or as may be changed by a prior written contract between the Buyer and RSG Products Inc., and any attempt to alter or omit any of such terms shall be deemed a rejection and a counteroffer.



Warranty Policy

RSG Products Inc., warrants that each of its Air Conditioning Systems (the "Equipment") shall be free from defects in material and workmanship under normal use and service until one year after its date of invoice if, and only if, installation, maintenance and operation of the Equipment is in accordance with the specifications and instructions provided by RSG Products Inc. and no substitute parts are installed in accordance with the specifications and instructions provided by RSG Products Inc. and no substitute parts are installed in the equipment without the prior written authorization from RSG Products Inc.. For the complete kit and its components, the warranty period is 12 months or 1,000 hours, whichever comes first, from the date of invoice. If the Warranty Registration Form is completed and **returned within 1 month** of receipt of product, warranty terms will be extended from 12 months to 18 months. In the case of new spare parts, this warranty is limited to a period of 6 months from the date of invoice. In the case of rebuilt products, this warranty is limited to a period of 3 months from the date of invoice. Any claims under this warranty shall be made to RSG Products Inc., 440 West Lane, Suite 100, Saginaw, Texas 76131, USA. Warranty is not valid unless the [Warranty Registration Form](#) is completed and returned to RSG Products Inc. prior to any claim. The [Warranty Claim Request Form](#) must be completed to receive an RMA Number and the required documentation to be returned with the Equipment. A Warranty Claim without a Return Material Authorization (RMA) Number or a completed Warranty Registration Form will cause delays and a possible denial of the claim. All claims shall be handled according to standard warranty repair procedures.

Limitations & Exclusions. This warranty shall not apply to any Equipment repaired or altered outside the Rotorcraft Services Inc. Service Department unless express prior written authorization is granted: nor shall this warranty apply to any Equipment that has been subjected to misuse or accident, as determined solely by Rotorcraft Services Inc. The sole responsibility and liability of RSG Products Inc. and your exclusive remedy under any claim arising out of, connected with, or resulting from this sale or the performance or breach or any condition of warranty there under, or from the manufacture, delivery, or use of the Equipment shall be the repair or replacement of defective equipment upon return of the defective equipment to RSG Products Inc. with transportation, customs and any applicable import duties prepaid and provided that an inspection by RSG Products Inc. discloses that the equipment is defective and covered by this warranty. RSG Products Inc. shall not be liable for any labor or other charges necessary to remove or reinstall the Equipment. In no event, whether as a result of a breach of contract, warranty, tort (including negligence) or otherwise, shall RSG Products Inc. be liable for any special, consequential, incidental or penal damages or expenses including but not limited to loss of profit, goodwill or revenues, loss of use of the Equipment or any associated equipment, damage to associated equipment, cost of capital, cost of substitute products, facilities or services, down time, or costs or claims of third parties for such damages or expenses.

THE FOREGOING WARRANTY IS EXCLUSIVE AND IN LIEU OF ALL OTHER WARRANTIES OR REMEDIES WHETHER WRITTEN, ORAL, IMPLIED OR STATUTORY, ANY AND ALL IMPLIED WARRANTIES OF MERCHANTABILITY, FITNESS FOR A PARTICULAR PURPOSE, COURSE OF DEALING OR USAGE OF TRADE ARE HEREBY EXPRESSLY DISCLAIMED AND EXCLUDED. Acceptance of the Equipment by you shall constitute your acknowledgement and acceptance of the terms, provisions, limitations and exclusions set forth herein. Such term, provisions, limitations and exclusions shall not be modified, deleted or supplemented. In a case where the purchaser has negotiated warranty terms by express written agreement with RSG Products Inc. as to certain equipment, the terms of that agreement shall supersede the warranty.

Extended Warranty. The extended warranty that is available for a fee at time of original purchase of the new product applies an 18 month period to the foregoing warranty.



WARRANTY REGISTRATION FORM

DATE: _____

CUSTOMER NAME: _____

ADDRESS: _____

CITY: _____ STATE: _____ ZIP: _____

PHONE NUMBER: (____) _____ FAX NUMBER:(____) _____

COMPONENT NAME: _____

PART NUMBER: _____ SERIAL NUMBER: _____

TYPE AIRCRAFT: _____ N#: _____ S/N: _____

AIR CONDITIONING INSTALLATION DATE: _____

AIR CONDITIONING INSTALLATION COMPANY: _____

DATE INSTALLED: _____ T.T AT INSTALLATION: _____

COPY OF T.T. LOG BOOK ENTRY OF A/C INSTALL SIGN OFF.

This Form Must be received from the Owner of the Aircraft for the warranty to be active.

Warranty period extends from Date of Purchase for a period of one year or 1000 hours

Subject to the limitations identified in the attached Warranty Policy; effective 1 July 2013. If warranty registration form is completed and returned within 1 month of receipt of product, warranty terms will be extended from 1 year to 1 year and 6 months.

**PLEASE REVIEW RSG PRODUCTS, INC. WARRANTY POLICY
PRIOR TO SUBMITTING THIS REGISTRATION FORM.**

Return Material Authorization (RMA) Form

	RMA Number:	
	Date Issued:	
	Issued by:	

<p>RMA Instructions: Products purchased through RSG may be returned by following these steps:</p> <p>1. Contact RSG at 817-624-6600 or info@rotorcraftservices.com to notify Customer Support of needed RMA.</p> <p>2. Completely fill out this form, and email it to Customer Support, who will provide an RMA number. Print completed RMA form & place in the box with the item(s) being returned.</p> <p>3. Clearly mark the outside of the box with the RMA number.</p> <p>4. Ship the item(s) to: RSG Products, Inc. 440 West Ln., Suite 100 Saginaw, TX 76131</p> <p>Please refer to RSG's Warranty Policy and RMA Policy for complete details regarding product returns.</p>	Company Name			
	Address			
	City			
	State		Zip/Postal Code	
	Country			
	Phone Number			
	Contact Name			
	Email			
	Return Ship Method		Shipping Account Number	

Returned Item(s)					
Part Number / Serial Number	Quantity	Purchase Date	Invoice # or PO #	Reason for Return	Aircraft Tail # and Serial Number

Additional Comments:

*****You must submit a copy of the logbook page when items being returned were installed*****

Disposition (To be completed by RSG)

<i>Returned to customer, no problem found (eval fee applies)</i>		<i>Non-Warranty replacement (from stock-quote issued)</i>
<i>Warranty rebuild (rebuilt and returned to customer)</i>		<i>BER, Not rebuild-able, informed customer (eval fee applies, scrap?, RTC?)</i>
<i>Non-Warranty rebuild (quote issued - rebuilt and returned to customer)</i>		<i>Warranty Replacement (from stock-no fee applies)</i>
<i>Other:</i>		

RSG Products, Inc.
RMA (Return Material Authorization) Policy

All returns require an RMA number. Contact RSG Products (RSG) via telephone at 817-624-6600 or email at info@rotorcraftservices.com to obtain an RMA number. Returns will be authorized in accordance with the following policy: If it is deemed that the part should be returned, a representative from RSG will send you an RMA form. Completely fill out the RMA form and email it to Customer Support to obtain an RMA number. Once RMA is issued, place copy of RMA form, **and copy of logbook entries**, in the box with the item(s) being returned. Clearly mark the outside of the box with the RMA number. Products will not be accepted by RSG for return if not accompanied by a valid RMA number. Return shipping for all RMA items will be at the expense of the customer.

Stock Returns

Stock returns must be made within thirty (30) days of the invoice date. Authorization of stock returns is at the sole discretion of RSG. If a stock part is authorized for return and is a customer error, 25% of the purchase price will be applied as a standard restocking charge. Parts must be new, unused, and contain all the original packaging and paperwork (certs, 8130-3, packing slip...etc). There is no restocking fee due to errors by RSG if correct order information was furnished with the original order.

Warranty Returns

Products to be returned for warranty coverage must be within the applicable warranty period. If the customer requests that a replacement be sent immediately, a rebuilt-to-new unit (if available) will be shipped to the customer. If evaluation of the returned item shows damage or misuse, or if it is found in good working order, the replacement product will be billed to the customer's account in accordance with RSG's standard payment terms. Then, once a final decision of the return is made, a credit will be issued if the warranty claim is allowed.

Non-Warranty Returns

If the customer wishes to return a part for evaluation that is no longer within the warranty period or for damage not covered by the warranty, RSG will advise the customer of the estimated cost to rebuild-to-new. Return of the product, with a purchase order noting the quoted cost to rebuild will be considered authorization to proceed, and agreement to pay for the cost to rebuild, whether or not it exceeds the original estimate. A \$300 evaluation fee will apply to all non-warranty returns. This fee will be deducted from the total quoted to rebuild the part to new.

Transportation Charges

The customer is responsible for all transportation, insurance, duties and other similar charges for all returned items, and the customer must ensure that the product is appropriately packaged. Products shipped to RSG freight collect will be refused. Shipping damages resulting from improper packaging will be the customer's responsibility. After evaluation and/or rebuild, RSG will return the product using the method stated on the front of this form. Products will not be accepted by RSG for return if not accompanied by a valid RMA number, which must be clearly marked on the outside of the package.

RMA Closing Procedure

The RMA will be closed if RSG has not received the RMA requested items from the customer within (60) days of RMA assignment date.

Once returned parts are evaluated, if deemed non-rebuildable or BER, customer will be invoiced the \$300 evaluation fee. If customer does not respond within (60) days, RMA returned part will be scrapped on site by RSG or shipped back to the customer.

By choosing to request an RMA number from RSG, it is implied that the customer has agreed to the terms of this RSG RMA Policy.

Rev.	Desc.	Reviewed	Approved	Date
IR	Initial Release of New Document	K. Musgraves	G. Thompson	05/21/2022

RSG Products Inc.

440 West Ln, Suite 100, Saginaw, TX 76131

www.rotorcraftservices.com

Step 15

Trouble Shooting Guide

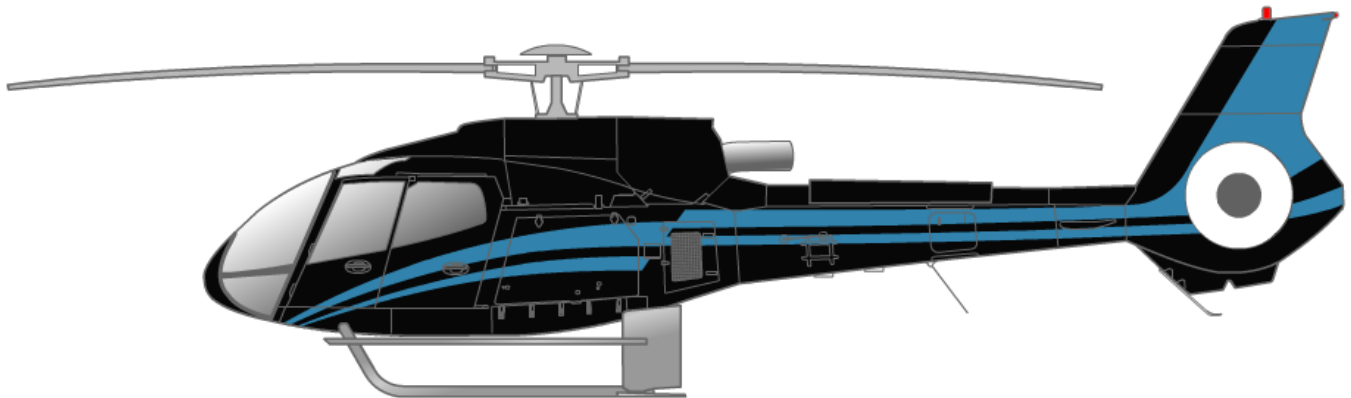

Servicing and Trouble Shooting Guide

AS350 (Series) and EC130 B4

Air Conditioning System

TROUBLESHOOTING YOUR AIR CONDITIONING SYSTEM

The following consists of some basic information on Freon System Operation.

We should probably define “cold”. Actually, for our purpose, “cold” is a relative term. Your air conditioner should produce air (measured at the duct) that is:

- • 36° to 50° F at 70° ambient temperature.
- • 40° to 52° F at 80° ambient temperature.
- • 46° to 60° F at 90° ambient temperature.
- • 50° to 75° F at 100° ambient temperature.

An Empty System

If the system is empty, the search for leaks should begin with a good visual check. Is it a fast leak or a slow leak? When was the system last charged? If it's a newly installed and filled system, then look for obvious leaks like a chaffed, punctured or ruptured hose, or a loose fitting. (See the recharge and leak testing section for hints on charging new systems.)

Freon leaks can be very tough to find. Freon is colorless, odorless, heavier than air, and it evaporates as soon as it hits the atmosphere. The only helpful thing about it is the fact that the oil carried with the refrigerant, so any sizable leak will leave a trail of oil at the offending hose or fitting. It will often just be a dark area, and the amount of oil might be slight. But if you find an air conditioning fitting with an oily residue and the area around it is dry, you've probably found your leak. A good electron detector can verify your visual diagnosis.

Because the system carries the oil in suspension with the refrigerant, any sizable leak will leak oil as well as refrigerant. Very slow leaks will usually only vent refrigerant and not oil, but a fast leak like a ruptured hose or a very loose fitting, will leak the refrigerant so fast that the oil is carried out of the system as well. If your system has suffered a major leak, be sure to check the oil level in the compressor before refilling the system.

Troubleshooting

Trouble: Low or partial refrigerant charge

Symptoms:

- Insufficient cooling
- Low-side pressure too low
- High-side pressure too low
- Receiver/drier sight glass shows a stream of bubbles
- Air in ducts only slightly cool

Cause: The system is low on refrigerant, probably caused by a leak.

Correction: Find and fix the leak. If there was a loss of oil, be sure to check the compressor oil level. Evacuate and recharge.

A System Full of Refrigerant

First, you should double-check all the obvious things (i.e. the compressor clutch, the belt tension, and the operation of the evaporator blower). Next, establish some baseline conditions for your testing: run aircraft, high blower and coldest thermostat setting, doors and windows closed, ambient temperature of 70° F or above.

Situations do occur where the system is full of refrigerant, yet the sight glass remains cloudy. The first thing to consider is whether the receiver/drier is installed backwards. Be sure the line from the condenser goes to the port marked “in” on the receiver/drier. The other condition that might give you a cloudy glass (on a full system) is a restriction in the liquid line from the condenser to the receiver/drier. On some new receiver/driers the filter screen could be pushed up so the bottom of the screen is blocking the liquid pickup tube. You will have to cut open the receiver-drier to confirm your diagnosis.

You should test next for a system that is overcharged. If the sight glass is clear, but the high- and low pressure gauge readings are high (300 or more on the high side, 50 or more on the low side), disconnect the compressor clutch. (Note that on HFC-134A systems, milky is the normal look for a correctly charged system.) The refrigerant should foam and then settle away from the glass in less than forty-five seconds. If the sight glass remains clear for more than forty-five seconds you have an overcharged condition and will have to remove Freon.

Trouble: Excessive moisture in the system

Symptoms:

- Insufficient cooling during hottest part of the day or during extended flying.
- Low-side pressure normal, though it may be too low or even a vacuum
- High-side pressure normal, though it may be low-at the same time low side is low
- Receiver-drier sight glass may show tiny bubbles
(*Note:* This could be a tough call with HFC-134A since the sight glass is always milky).
- Air in the ducts is usually cold, but becomes warm when pressure reading drop

Cause: Excessive moisture in the system. The drying agent in the receiver-drier is saturated with moisture, which is released to the system when outside temperature increased. Moisture in the system collects and freezes on the expansion valve, stopping the flow of refrigerant.

Correction: Suck all the CFC-12 from the system. Replace or rebuild the receiver-drier. Evacuate and recharge.

Trouble: Air in the system

Symptoms:

- Insufficient cooling
- Low-side pressure normal, but does not drop when the clutch cycles
- High-side pressure high
- Receiver/drier sight glass shows occasional bubbles (Note again that with HFC-134A the sight glass should be milky when the system is fully charged.)
- Air in ducts only slight cool

Cause: Refrigerant contains non-condensable in the form of air and moisture.

Correction: Leak test, watch for bad compressor seals. Drain the system. Repair leaks as needed. Replace or rebuild the receiver-drier. Check the compressor oil. Evacuate and recharge.

Trouble: Condenser malfunction or system overcharge

Symptoms:

- No cooling
- Low-side pressure too high
- High-side pressure too high
- Receiver/drier sight glass may show occasional bubbles
- Liquid line very hot
- Air in ducts is warm

Cause: The condenser is not function properly because of high head pressure. System may be overcharged.

(**Note:** Technicians will have to be especially careful to avoid overcharging HFC-134A systems. Because the sight glass is hard to read and the volume given is slightly lower with HFC-134A).

NOTE:

Cloudy Sight Glass

A cloudy sight glass indicates a system that is only partially full of refrigerant (with a few exceptions). A perfectly clear sight glass (use a light to get a good look) means the system is either full or empty. Note, with HFC-134A the glass appears milky when properly charged, and may show occasional bubbles.

AS350/B4 Trouble Shooting Guide



1. System has no electrical power to air conditioner master control box:
 - A) Check 50 amp circuit breaker or fuse in aircraft electrical bus.

2. System has power but will not turn on:
 - A) Check 5 amp circuit breaker on switch assembly.
 - B) Check ground lead on cannon plug 102 wire IFS105N20.
 - C) Check evaporator fan relay in air conditioner master control box.

3. Forward evaporator fan will not turn on, but aft fan runs:
 - A) Check 20 amp circuit breaker in master electrical box.
 - B) Check ground wire from evaporator motor.
 - C) AS350 disconnect CP104 and check for power on pin 2. On AS350 or EC130 B4 by checking ground lead from master switch.
 - 1) If you have power, your motor is bad.
 - 2) If no power, disconnect CP101 cannon plug and check continuity from pin 6/c on CP101 to cannon plug CP104 pin 2. If no power, check cannon plugs and switch.

4. Aft evaporator fan will not run, but forward evaporator runs:
 - A) Check 20 amp circuit breaker on master electrical box.
 - B) Check ground wire from fan.

AS350/B4 Trouble Shooting Guide



5. Condenser fan/fans do not operate:

- A) Check 20 amp circuit breaker.
- B) Check 1 amp circuit breaker.

- 1) If popped, reset.
 - a) Check brushes.
 - b) Check power.
 - c) Check ground.
 - d) Check fins for blockage in air condenser assembly.
- 2) Run air conditioning system.
 - a) Check pressures, If pressure is running higher than normal, then continue with b), ect...
 - b) System may be over-serviced.
 - c) System may be contaminated by improper Freon or a mix of Freon's.

- 1) **NOTE:** This has happened more than once. The service carts are great for servicing systems, but there is a danger in its misuse. Untrained operators or an individual who wants to service his car, truck, motor home or even his room A/C can pump down their system into your tank. It can have any number of different Freon's. It could also be contaminated by a failed compressor, dryer bottle, wrong oil or any number of things. This has happened to a company with brand new equipment just 3 weeks old. There were large warning signs on this service cart, designated HELICOPTER SERVICE ONLY. They had one for ground equipment. All of the mechanics were well trained except for the management, janitors and their family members of the company. It can happen to any operator.

6. Compressor clutch does not engage, but air conditioner fans work.

- A) Check clutch for power.

- 1) If power, clutch coil may be bad or air gap in clutch face may be too excessive.
- 2) If NO power check system for total Freon loss.
- 3) If system is serviced and still no Power and you have an optional temperature controller, you can bypass by jumping pins 3 and 4 on CP102 to check if faulty.

AS350/B4 Trouble Shooting Guide



7. System not cooling:

- A) Check that air condenser fan/fans are blowing.
- B) Check clutch engagement. Is clutch staying engaged or cycling? Check belt tension.
- C) Check to see if air condenser coil is free from debris and fins are clean and not rolled over blocking air flow.
- D) Check evaporator return air inlets, that they are not blocked and fins are clean and not rolled over blocking airflow.
- E) Put gauges on system. Run system and check pressures also measure Delta temperature from both evaporators. (Measure inlet temperature and outlet temperature to get Delta. This is a must, do not rely on just using your hand and guessing).
- F) Check sight glass.

(NOTE: There are several ways to service Freon systems:

- 1) Service system to a clear sight glass R12.
Note: On 134a systems the sight glass appears milky when properly charged, though there may be occasional bubbles in the sight glass.
- 2) Service system by weight. If you have a service station or scale, you can add the proper amount by weight.

82° F or higher service with 2.0 lbs max Freon.

Below 82° F service with 2.5 lbs max Freon.

- 3) The optimum method for best performance is to use at least two mechanical thermometers and place them near the return air and the discharge air of each evaporator. R-134a can then be added or deleted as required, until the highest T.D. is noted per the paragraph below. At that time, the correct amount of refrigerant is installed. At any time the high pressure gauge reaches 280 psi, stop servicing. Do not exceed 3.0 lbs of refrigerant..
- 4) Service according to a standard pressure temperature chart.)

8. One evaporator is cooling, one is not.

- A) One expansion valve may be blocked from contamination.
- B) One expansion valve may be locked full open.
(NOTE: The one valve that is full open is causing the problem. It may make it seem like the other valve is bad and not working.)
- C) One of the sensing bulbs on expansion valves may become loose from suction side of coil. Also check to see if sensing bulb is mounted to the correct evaporator tube. The bulb should be mounted at 9 or 3 o'clock position.
- D) Hose may be crimped, kinked or have a fitting bent over blocking flow.
- E) (NOTE: The recommended fix is to pump down system. Change BOTH expansion valves and dryer bottle. Make sure to mount sensing bulb on suction side of coil and when possible at 9 or 3 o'clock position on tube. Re-service system.)

AS350/B4 Trouble Shooting Guide



9. Compressor clutch failure:

- A) Low Freon in system. This causes the system to low pressure out through the low pressure switch. It will cycle the clutch on and off until it heats up causing the coil to overheat and fail, or heat up the bearing to the point the grease will liquefy and run out. This will add to the heat and help fail coil or bearing.
- B) Air gap on clutch may have changed.
- C) Coil may have weakened.
- D) Bearing may have failed, causing clutch to slip and fail coil.
NOTE: If ongoing maintenance is not maintained on compressor clutch bearing as prescribed in IFS maintenance manual, bearing may fail.

10. Compressor failed:

- A) Loss of oil or insufficient oil.
- B) Low Freon in system, causing insufficient flow of oil lubricant.
- C) Contamination in system.
- D) Compressor bearing failed.
- E) Over servicing of system to the point of liquid lock.
(NOTE: This has happened.)

11. Compressor belt failure:

- A) Low Freon in system. Cause: low pressure switch to cycle the clutch on and off excessively.
- B) Insufficient belt tension.
- C) Clutch bearing dragging or failing. This causes excessive belt slipping.
- D) Over service of system.
- E) Air gap excessive, causes clutch to slip heating pulley. This will stretch belt making it slip.

12. Air conditioner runs, but pops 1 amp circuit breaker:

- A) Check condenser fan or fans for operation.
- B) Check blockage of air flow in and out of condenser.
- C) Check coil to see if fins are clean or rolled over.
- D) Check for over service of Freon.
- E) Put gauges on and run system.
 - 1) Is system popping 1 amp circuit breaker at 350 or higher?
 - a. If not change high pressure switch.
- F) Check expansion valves and make sure sensing bulbs are mounted to suction lines.
 - 1) Measure Delta of both evaporators.
 - a. If Delta is over 32° F expansion valve may not be working. If expansion valve is not throttling it will dump too much Freon. This can add excessive heat to condenser and can also freeze up coil.
 - 2) If Delta is below 14° F. Change valves, they may be blocked internally.

AS350/B4 Trouble Shooting Guide



13. Fresh air supply valve inoperable. EC130 B4 only

A) If valve fails to open.

- 1) Check 2 ½ amp CB
- 2) Check for power at wire IFS 104V20
 - a. If power, check for power on wire IFS 104E20
 1. If no power motor/controller is bad
 2. If power trace back to source
 - b. If no power check continuity to Pin 1 on cannon plug CP101.
 - c. If no continuity check low pressure switch for ON.

B) If valve fails to close

- 1) Check for power on wires at valve IFS 104V20 and IFS 104E20
 - a. If power, both motor /controller is bad.
 - b. If no power on wire IFS 104V20.
 - a. Check 2 ½ amp CB.
 - b. Check to see if low pressure switch is open.
 - c. Check continuity from valve wire IFS 104V20 to Pin 1 on cannon plug CP101.

NOTE:

When running in “A/C” mode and you switch straight to “OFF” the Fresh Air Valve will stay in the closed position. You will need to switch to the “Fan” position to reset the Fresh Air valve to the open position.

SERVICE OPERATIONS CLUTCH

14.1 Armature Assembly Removal

1. If armature dust cover is present, remove the 3 or 6 bolts holding it in place and remove cover. If auxiliary sheet metal pulley is present, remove the screws holding it in place. Then remove pulley.
2. Insert pins of armature plate spanner into threaded holes of armature assembly.
3. Hold armature assembly stationary while removing retaining nut with 3/4", 19mm, or 14mm socket wrench, as appropriate.
4. Remove armature assembly using puller. Thread 3 puller bolts into the threaded holes in the armature assembly. Turn center screw clockwise until armature assembly comes loose.
5. If shims are above shaft key, remove them now. If shims are below shaft key, the key and bearing dust cover (if present) must be removed before the shims can be removed.
6. Remove bearing dust cover (if present). Use caution to prevent distorting cover when removing it.
7. Remove shaft key by tapping loose with a flat blade screwdriver and hammer.
8. Remove shims. Use a pointed tool and a small screwdriver to prevent the shims from binding on the shaft.

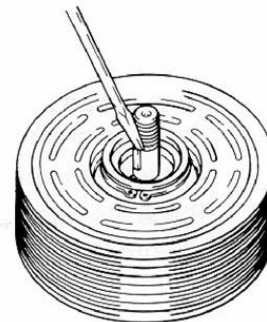
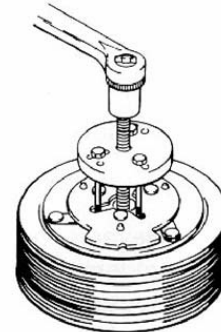
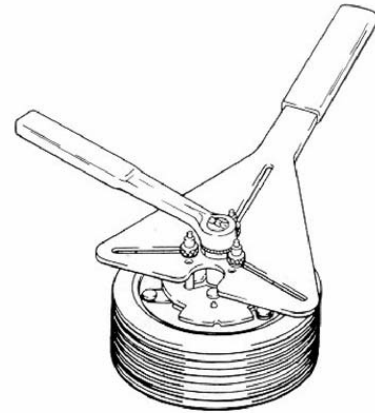

SERVICE OPERATIONS - CLUTCH

14.2. Rotor Assembly Removal

1. If bearing dust cover has not been removed, remove it now. See step 6 of Section 14.1, for Armature Assembly Removal.
2. If internal snap ring for bearing is visible above the bearing, remove it with internal snap ring pliers.
3. Remove rotor snap ring.
4. Remove shaft key.
5. Remove rotor pulley assembly:
 - Insert the lip of the jaws into the snap ring groove
 - Place rotor puller shaft protector (Puller set) over the exposed shaft.
 - Align thumb screws to puller jaws and finger tighten.
 - Turn puller center bolt clockwise using a socket wrench until rotor pulley is free.

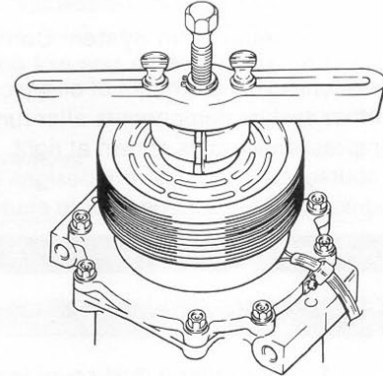

14.3 Field Coil Assembly Removal

1. Loosen lead wire clamp screw with #2 Phillips screwdriver until wire(s) can be slipped out from under clamp.
2. Undo any wire connections on the compressor which would prevent removal of the field coil assembly.
3. Remove snap ring.
4. Remove the field coil assembly.

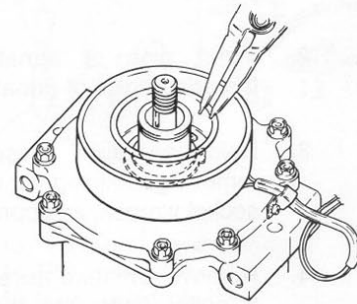

14.4 Field Coil Assembly Installation

Reverse the steps of Section 14.3. Protrusion on underside of coil ring must match hole in front housing to prevent movement and correctly locate lead wire(s).

14.5 Rotor Assembly Installation

1. Place compressor on support stand, supported at rear end of compressor. If the compressor must be clamped in a vice, clamp only on the mounting ears, never on the body of the compressor.
2. Set rotor squarely over the front housing boss.
3. Place the rotor installer ring into the bearing bore. Ensure that the edge rests only on the inner race of the bearing, not on the seal, pulley, or outer race of the bearing.

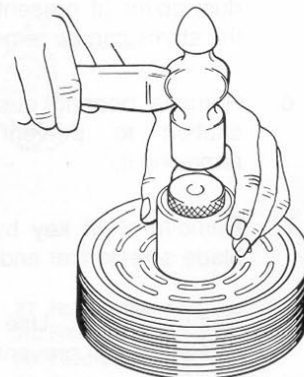

SERVICE OPERATIONS - CLUTCH

4. Place the driver into the ring and drive the rotor down onto the front housing with a hammer or arbor press. Drive the rotor against the front housing step. A distinct change of sound can be heard when using a hammer to install the rotor.
5. Reinstall rotor bearing snap ring, if it has been removed, with internal snap ring pliers.
6. Reinstall rotor retaining snap ring with external snap ring pliers. If a bevel is present on the snap ring, it should face up (away from the body of the compressor).
7. Reinstall rotor bearing dust cover (if present) by gently tapping it into place.

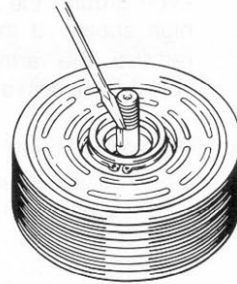

14.6 Armature Assembly Installation

1. Install shaft key with pliers.
2. Install clutch shims. NOTE: Clutch air gap is determined by shim thickness. When installing a clutch on a used compressor, try the original shims first. When installing a clutch on a compressor that has not had a clutch installed before, first try 0.04", 0.02", and 0.004" (1.0, 0.5, 0.1 mm) shims.
3. Align keyway in armature assembly to shaft key. Using driver and a hammer or arbor press, drive the armature assembly down over the shaft until it bottoms on the shims. A distinct sound change will be noted if driving with a hammer.
4. Replace retaining nut and torque to specification.
1/2-20: 20-25 ft•lb (27-34 N•m, 270-350 kg•cm)
M8: 11-15 ft•lb (15-21N•m, 150-210kg•cm)

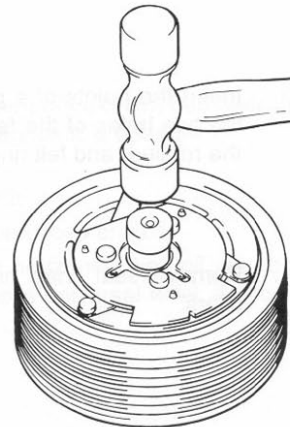
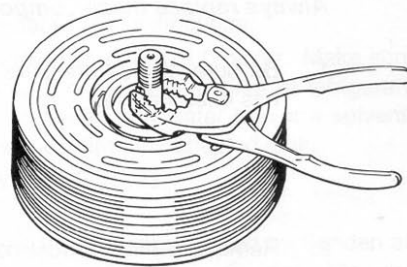

SERVICE OPERATIONS - CLUTCH

5. Check air gap with a feeler gauge. Specification is 0.011" - 0.019" (0.3 - 0.5mm). If gap is not even around the clutch, gently tap down at the high spots. If the overall gap is out of spec., remove the armature assembly and change shims as necessary.

6. Replace armature dust cover (if used) and torque 3 or 6 bolts to specification below.
3 - 1/4-20 bolts (SD-5): 2-4 ft•lb
(2-5 N•m, 25-50 kgf•cm)
6 - M5 bolts (SD-7): 5-8 ft•lb
(7-11 N•m, 70-110 kgf•cm)

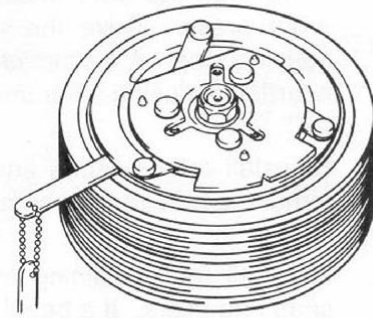

Note: Over torque of SD508/5H14 dust cover bolts will cause air gap to become out of spec.

REVISION RECORD				
DWG REV LTR	DATE	DESCRIPTION OF CHANGE	APPVD BY	REV BY

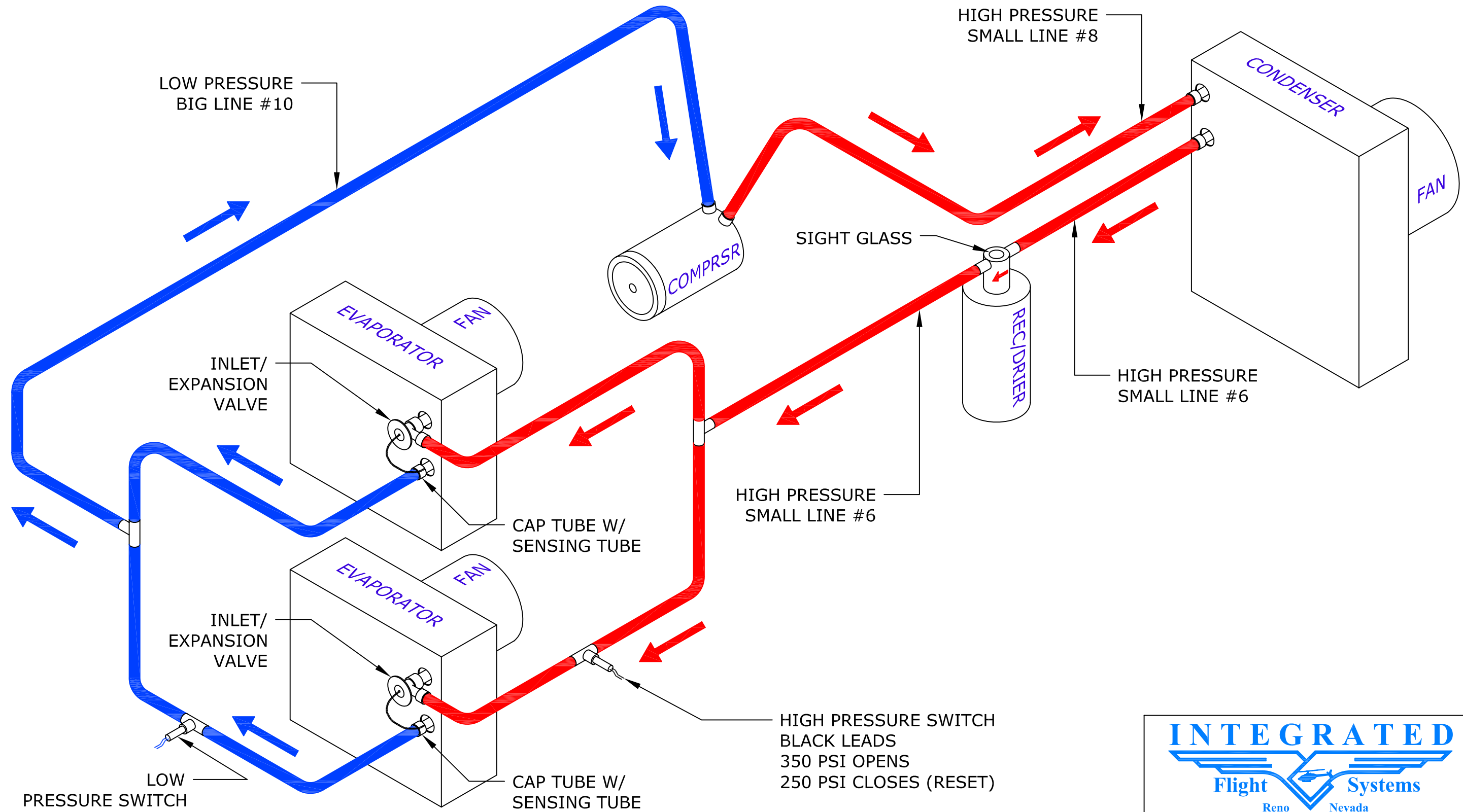

INTEGRATED
Flight Systems
Reno Nevada

TITLE: SIMPLE AIR CONDITIONING SCHEMATIC

DRAWN BY: JTYE	DATE: 04/10/06	REV: -	SCALE: NONE	SHEET: 1 OF 1
APPLICATION: N/A			DWG No. A/C SCHEMATIC	

LOW PRESSURE SWITCH
BLUE LEADS
22 PSI CLOSSES
7 PSI OPENS

HIGH PRESSURE SWITCH
BLACK LEADS
350 PSI OPENS
250 PSI CLOSSES (RESET)

LOW PRESSURE
BIG LINE #10

HIGH PRESSURE
SMALL LINE #8

HIGH PRESSURE
SMALL LINE #6

HIGH PRESSURE
SMALL LINE #6

SIGHT GLASS

CAP TUBE W/
SENSING TUBE

CAP TUBE W/
SENSING TUBE

INLET/
EXPANSION
VALVE

INLET/
EXPANSION
VALVE

EVAPORATOR

EVAPORATOR

COMPRSR

RECIPIER

CONDENSER

FAN