

ASG **PRODUCTS INC.**

Air Conditioning System Installation Manual for

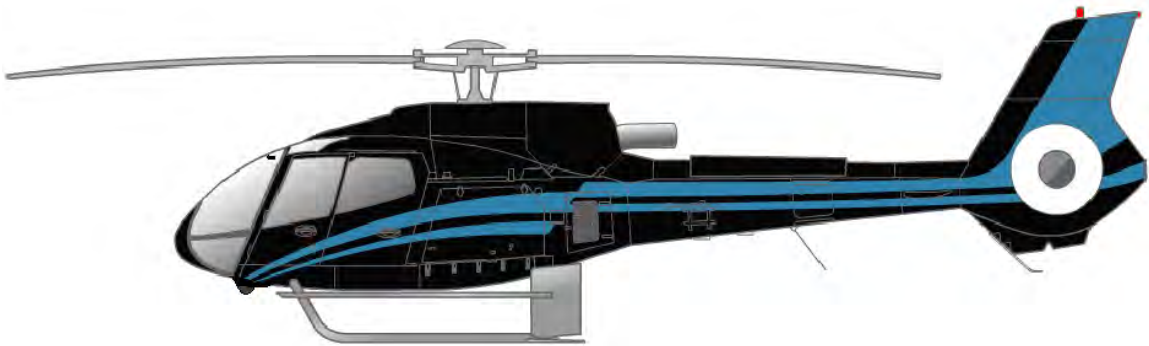

130-00-031-HP Corporate Version

(Revised: May 17, 2024, Rev: J)

1	KIT INVENTORY
2	AIRCRAFT PRE-INSPECTION
3	AIRCRAFT PREPERATION
4	REMOVAL OF FACTORY COMPONENTS
5	INSTALLATION OF AFT EVAPORATOR
6	INSTALLATION OF CONDENSER
7	INSTALLATION OF FWD EVAPORATOR
8	INSTALLATION OF COMPRESSOR
9	INSTALLATION OF ELECTRICAL
10	INSTALLATION OF HOSES
11	PAPERWORK
12	CONTINUED AIRWORTHINESS
13	PARTS BREAK DOWN
14	T&C/WARRANTY/RMA
15	TROUBLE SHOOTING GUIDE

RECORD OF REVISIONS

Revision	Description	Date	Revised By
IR	Initial Release	10 June, 2003	IFS
A	Additions and Corrections	30 June 2006	IFS
B	Revisions and Additions	22 Feb, 2007	IFS
C	Revised Cont. Airworthiness	13 Aug, 2009	IFS
D	Incorporated STC Changes	04 Nov, 2009	IFS
E	Formatted document to RSG Products	01 Jun. 2015	RSG
F	Updated Section 1 & 6	08 Apr. 2016	RSG
G	Updated Section 1 & 7	21 Apr. 2017	RSG
H	Updated Sections 5, 7, 9, 12, 13, 14 & 15	15 Oct. 2022	RSG
J	Updated Sections 1, 5, 8-14	17 May 2024	RSG

LIST OF EFFECTIVE PAGES

Rev	Section	Pgs	Description	Date
B	1	Insert	Revised Parts List	02/22/07
E	1	Insert	Revised Parts List and added MSDS docs.	06/01/15
F	1	Insert	Revised Parts List	04/08/16
G	1	Insert	Revised Parts List	04/21/17
H	1	10-23	Revised Kit List	10/15/22
J	1	10-23	Revised Kit List to Rev R	05/17/24
A	2	1-4	Revised for Clarity	06/30/06
A	3	1-3	Revised for Clarity	06/30/06
A	4	1-8	Revised for Clarity	06/30/06
B	5	1-14	Added Resistor Mount	02/22/07
E	5	Insert	Updated drawings	06/01/15
H	5	52	Reworded instructions in Step 5.11 to remove resistor mount	10/15/22

H	5	58	Updated photo to remove resistor	10/15/22
H	5	64-70	Updated 4-1-EC130 drawing	10/15/22
J	5	64-66	Updated 4-1-EC130 drawing	05/17/24
A	6	1-7	Revised for Clarity	06/30/06
E	6	Insert	Updated drawings	06/01/15
F	6	2	Revised Section 6.2 & 6.9	04/08/16
A	7	1-10	Revised for Clarity	06/30/06
E	7	Insert	Updated drawings	06/01/15
G	7	3-4	Revised Section 7.12 & 7.19	04/21/17
H	7	85	Removed step 7.9 due to obsolescence	10/15/22
H	7	97-99	Updated 5-1-EC130 drawing	10/15/22
H	7	101-103	Updated 5-4-EC130 drawing	10/15/22
A	8	1-5	Revised for Clarity	06/30/06
E	8	Insert	Updated drawings	06/01/15
H	8	109-112	Updated 6-1-EC130 drawing	10/15/22
H	8	116-120	Added <i>Reference Only</i> drawings 6-2-AS350 & 6-3-AS350	10/15/22
J	8	113-118	Updated <i>Reference Only</i> drawing 6-3-AS350	05/17/24
B	9	1-3	Added Switch Panel 540012	02/22/07
E	9	Insert	Updated drawings	06/01/15
H	9	124-126	Updated 2-1-EC130 drawing	10/15/22
J	9	122	Updated 2-1-EC130 drawing	05/17/24
A	10	1-7	Revised for Clarity	06/30/06
E	10	Insert	Updated drawings	06/01/15
J	10	134-135	Added 3-1-EC130 drawing	05/17/24
B	11	1-2	Added Brazilian STC	02/22/07
D	11	2	Updated STC changes	11/04/09

E	11	2	Updated to RSG	06/01/15
E	11	Insert	Updated STC Cover Sheet	06/01/15
J	11	138-141	Updated weight & balance page from ICA Rev F-1, Updated STC page	05/17/24
J	11	147-158	Added MDL Rev V	05/17/24
C	12	1-16	Revised for Clarity	08/13/09
E	12	Insert	Updated ICA	06/01/15
H	12	159-264	Revised ICA added	10/15/22
J	12	170-274	Updated ICA Rev F-1 added	05/17/24
A	13	1-2	Revised for Clarity	06/30/06
E	13	1-5	Updated to RSG	06/01/15
H	13	267-269	Updated 2-1-EC130 drawing	10/15/22
J	13	277	Updated 2-1-EC130 drawing	05/17/24
C	14	1-8	Revised Warranty	08/22/08
H	14	273-278	Updated Terms, Warranty & RMA Policy	10/15/22
J	14	284-286	Updated Warranty Registration & RMA Forms	05/17/24
D	15	Insert	Revised TS Guide	11/04/09
H	15	280-293	Updated TS Guide	10/15/22

Getting Started

The air conditioning system installation instructions are laid out step-by-step starting with one (1) thru nine (9) for installation and ten (10) thru fifteen (15) for care and airworthiness, the instructions are designed to be easy – to – use.

The example below is designed to give you a basic overview of how the steps work.

Example: A. In the step below there is a number **5.1** The “**5**” stands for step 5 and the “**1**” stands for direction 1.

Installation of Aircraft Systems

Example: B. When the parts are called out in a step: **5.1**, locate the part and parts that go with this step (5.1). It is best to organize your parts by step numbers so they can be drawn from as needed.

<u>Step</u>	<u>Procedure</u>	<u>Mech</u>	<u>Insp</u>
5.1	Position the aft evaporator doubler, P/N 261370, on the upper transmission deck per the dimensions shown on drawing number 4-1-EC130. Mark and remove all existing rivets, bolts, and nut plates to allow the doubler to sit flat on deck. (Ref photo 501)		

Should you have any questions, problems or need technical support, do not hesitate to call, fax, E-mail, or write us:

Phone: 1-888-545-8371 E-Mail: info@rotorcraftservices.com
Fax: 1-800-624-6603

RSG Products Inc.
REQUIRED TOOLS – B4 Air-Conditioning

Required Tools

1.	Drill ¼ or 3/8 Capacity / Straight and 90 degrees
2.	Rivet Gun - #4 & #5 Rivet Set
3.	Blind Rivet Puller
4.	Assorted Drill Bits - 40, 30, 10, ¼, & 21
5.	Standard Wrenches - ¼, 1-¼
6.	Metric Wrenches - 5mm to 19mm
7.	Standard Sockets - ¼ to ¾ cap Ratchet & Extensions
8.	Metric Sockets - 5mm to 19mm
9.	Torque Wrench (For Coupling) 200 <u>inch</u> lbs
10.	Rotary File (Die Grinder)
11.	Drum Sander
12.	Hole Finder - #30 & #10
13.	Cleco - #30, #21 & #40
14.	C-Clamps – Vise Grip Clamps
15.	Wire Cutters
16.	Phillips Screw Driver
17.	Torque-Bite (For Belly Pan) Pan American Tool 170-10 & 170-8 Power Torque
18.	Common Screw Drivers
19.	Cape Chisel
20.	Center Punch
21.	6 oz. Ballpeen Hammer for Removing Rivets
22.	Assorted Bucking Bars
23.	Safety Wire .032
24.	Wire Twisters
25.	Steel Ruler
26.	Spring scale

RSG Products Inc.
REQUIRED TOOLS – B4 Air-Conditioning

27.	Adjust Wrench Cap 1-1/2
28.	Vacuum Pump
29.	Gauge Manifold
30.	Nitrogen
31.	R-134A
32.	Blocks for Supporting Forward Engine
33.	Vacuum Cleaner
34.	Rivnut Puller

REVISION RECORD				
REV	DATE:	DESCRIPTION OF CHANGE	APPVD. BY	REV. BY
A	10/29/03	REVISED TITLE BLOCK. ADDED ALT LOCATION FOR ELECT. BOX		JTYE
B	09/01/14	CHANGED TITLE BLOCK AND REVISION BLOCK.		AJC

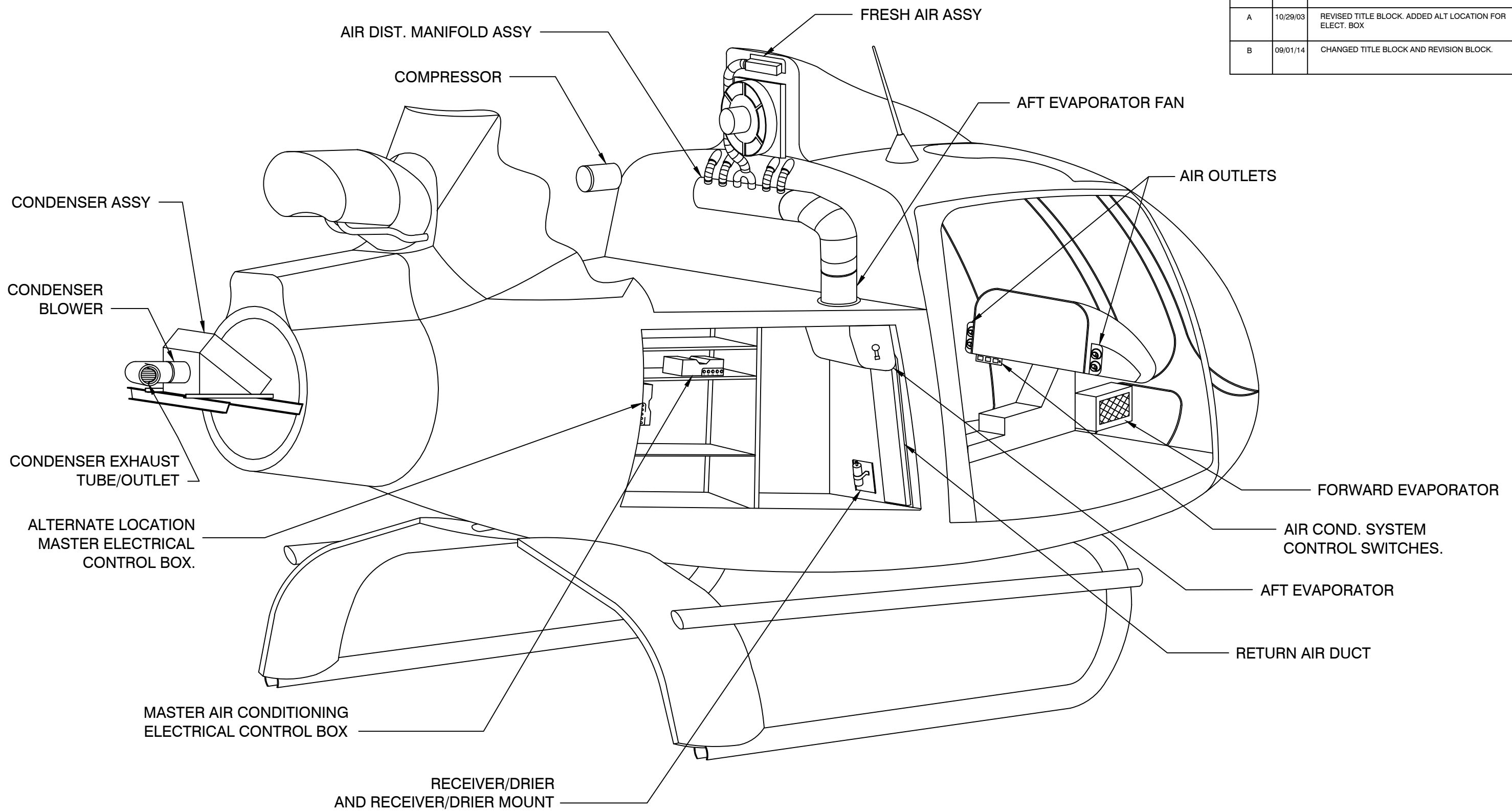

PROPRIETARY NOTICE TO ALL PERSONS RECEIVING THIS DOCUMENT THIS DOCUMENT AND INFORMATION OR TECHNICAL DATA AND DESIGNS CONTAINED HEREIN ARE PROPRIETARY DATA AND EXCLUSIVE PROPERTY OF RSG PRODUCTS INC. AND IS DELIVERED ON THE EXPRESS CONDITION THAT NEITHER THIS DOCUMENT NOR THE INFORMATION CONTAINED HEREIN SHALL BE DISCLOSED TO OTHERS, REPRODUCED IN WHOLE OR IN PART, OR USED FOR THE MANUFACTURE OR FABRICATION OF PARTS FOR ANYONE OTHER THAN RSG PRODUCTS INC. WITHOUT WRITTEN CONSENT AND AUTHORIZATION, AND THAT NO RIGHT IS GRANTED TO DISCLOSE OR SO USE ANY INFORMATION CONTAINED IN SAID DOCUMENT. THIS RESTRICTION DOES NOT LIMIT THE RIGHT TO USE INFORMATION OBTAINED FROM ANOTHER SOURCE.	NEXT ASSY.	TOLERANCES EXCEPT AS SHOWN
		.X: ±.1 .XX: ±.03 .XXX: ±.010 X.X°: ±.5° BREAK ALL SHARP EDGES .01 ALL DIMENSIONS IN INCHES UNLESS OTHERWISE STATED
	APPROVED BY:	DATE:

TITLE: AIR CONDITIONING OVERVIEW				
DRAWN BY: JTYE	DATE: 06/15/03	REV.: B	SCALE: N/A	SHEET: 1 OF 1
APPLICATION: EC 130 B4			DWG. NO.: 1-1-EC130	



Step 1

Kit Inventory

P/N 130-00-031-HP Corporate Version

(Rev. R)

March 8, 2024



RECORD OF REVISIONS

Revision	Description	Date	Revised By
IR	Initial Release	22 December 2008	IFS
A	Part Number Correction	06 May 2009	IFS
B	Opt. Switch and Mount Added to list	04 Nov. 2009	IFS
C	Optional Switch Removed	02 Feb. 2010	IFS
D	Corrected Screw Step 5.11	03 May 2010	IFS
E	Added EMI-RFI filter & ring terminals	16 Feb. 2011	IFS
F	Part Number Correction	02 Feb. 2014	RSG
G	Updated Compressor Bracket Kit	30 May 2014	RSG
H	Added Brushless Motor option & Alt. Config. Switch Panels	19 August 2014	RSG
J	Formatted to RSG Products. Updated P/N's.	11 June 2015	RSG
K	Removed items and corrected P/N's.	14 August 2015	RSG
L	Add 7" Brushless Motors with alternates.	08 Apr. 2016	RSG
M	Remove Alt. P/N	21 Oct. 2016	RSG
N	Add vent config. parts/hardware.	21 Apr. 2017	RSG
P	Corrected install drawing numbers	30 Aug. 2022	RSG
R	Updated part numbers	08 Mar. 2024	RSG

LIST OF EFFECTIVE PAGES

Rev	Pgs	Description	Date
A	2	Added List of Revisions	05/06/09
A	5	Added Screw AN525-10R6 Step 5.13	05/06/09
A	5	Corrected Duct PN's Step 5.14, 15 and 18	05/06/09
A	6	Removed Clamp PN Step 6.12	05/06/09
B	9	Added alternate Switch Assy. 540012	11/04/09
B	5	Added Resistor Mount Assy. 510463	11/04/09
C	9	Removed alternate Switch Assy. 540012	02/22/09



Air Conditioning System
Kit Part Number: 130-00-031-HP Corporate Version

D	5	MS35206-244 is now MS35206-230	03/05/10
E	8	Added EMI-RFI filter (P/N: LS03-01012)	02/16/11
E	8	Added 2 ring terminals (P/N: AP35110)	02/16/11
F	8	Corrected Comp. Bracket Kit P/N Step 8.9	02/02/2014
F	9	Corrected Ring Terminal P/N Step 9.5	02/02/2014
F	9	Corrected Switch Assy. P/N Step 9.8	02/02/2014
G	13	Corrected P/N of Compressor Bracket Kit	05/30/2014
H	5	Added optional Brushless Blower Motors in Step 5.11 (P/N: IFSS 050143, -1, -2, -3 DCB)	08/19/2014
H	8	Removed Step 7.9 and associated unneeded parts	08/19/2014
H	10	Corrected P/N in Step 9.5 (P/N: was 050015-2 is ANL-50)	08/19/2014
H	10	Added alternate switch assembly options Step 9.8 (P/N: 540011-02 and 540012)	08/19/2014
H	11	Added additional hardware	08/19/2014
H	11	Added optional EMI filters for Brushless Motors	08/19/2014
J	9	Formatted to RSG Products.	06/11/2015
J	10	Corrected part names Step 9.8	06/11/2015
K	5	Removed P/N 050143 in step 5.11	08/14/2015
K	6	Removed Resistor and components in step 5.11	08/14/2015
K	9	Replaced P/N 130-11-031 with note "SEE PAGE 14" in step 8.9	08/14/2015
K	11	Removed touch up paints from page 11	08/14/2015
K	14	Removed Kit P/N.	08/14/2015
L	7	Added 7" Blower Motor to step 6.9	04/08/2016
L	8	Added alt. Belt to section 8.5	04/08/2016
L	9	Added alt. compressor to section 8.9	04/08/2016
M	14	Remove Alt. P/N 261155 from Compressor Bracket Inst. Kit.	10/21/2016
N	8	Added vents and hardware for config. -02	04/21/2017
P	12	Corrected 2-3-EC130 drawing numbers and added reference drawings 6-2-AS350 and 6-3-AS350	08/30/2022
R	7	Updated 7" blower p/n in Step 6.9	03/08/2024
R	14	Updated alternate part numbers in comp. bracket kit	03/08/2024



Kit Configuration Inventory List: 130-00-031-HP Corporate Version

Customer Information

Sales Order Number:

Shipping Date:

Customer:

Customer P.O. Number:

Notes:

Kit Specifics

Kit S/N:

Condenser Blower S/N:

Condenser Blower S/N:

Aft Evaporator Blower S/N:

Compressor S/N:



Kit Configuration Inventory List

STEP	PART NAME	PART NUMBER	QTY	CHK'D BY	VERF'D BY
5.1	Right Half Doubler, Fan	261370	1		
5.4	Right Half Fan Doubler Shim	261371	1		
5.4	Rivet	MS20470AD4-4	55		
5.4	Rivet	MS20470AD4-5	50		
5.4	Rivet	MS20470AD4-6	15		
5.4	Rivet	MS20470AD5-5	15		
5.4	Rivet	MS20470AD5-6	15		
5.5	Return Air Duct	110015	1		
5.6	Aft Evaporator Assembly	560016-O-1	1		
5.7	Bolt	AN3-5A	4		
5.7	Washer	AN960-10	4		
5.9	Aft Return Air Screen Doubler	110008	1		
5.9	Aft Return Air Screen	080010	1		
5.9	Nut	MS21083-N3	20		
5.9	Screw	AN525-10R12	12		
5.9	Screw	AN525-10R8	8		
5.9	Washer	AN960-10	8		
5.9	Washer	AN970-3	20		
5.10	Aluminum Foil Tape	070076	60' ft.		
5.11	5" Vane Axial Blower Assy. (Brushless - dual speed)	IFSS 050143-2 DCB	1		
5.11	Bolt	AN3-5A	5		
5.11	Washer	AN960-10	5		
5.12	Air Distribution Manifold Assy. Comp.	520003-130	1		



Kit Configuration Inventory List

STEP	PART NAME	PART NUMBER	QTY	CHK'D BY	VERF'D BY
5.13	Washer	AN960-10	4		
5.13	Screw	AN525-10R6	4		
5.14	Foam Insulation Tape	070078	30' ft.		
5.14	2.5" Duct	060025	52" in.		
5.14	3" Band Clamps	060036	16		
5.15	5" Duct	060004	36" in.		
5.15	6" Band Clamp	060035	2		
5.17	Fresh Air Screen	080008	1		
5.17	Fresh Air Intake Assy.	540007	1		
5.18	3" Duct	060024	36" in.		
5.18	3" Band Clamp	060036	2		
6.1	Forward Brace, Condenser	261360	1		
6.2	Condenser Assembly	550003-O	1		
6.3	Aft Brace, Condenser	261361	1		
6.6	Bolt	AN4-5A	4		
6.6	Washer	AN960-416	8		
6.6	Nut	MS21044N4	4		
6.7	Bolt	AN4-5A	4		
6.7	Washer	AN960-416	8		
6.7	Nut	MS21044N4	4		
6.8	Bolt	AN4-6A	4		
6.8	Washer	AN960-416	8		
6.8	Nut	MS21044N4	4		
6.8	Washer	AN960-416L	12		



Kit Configuration Inventory List

STEP	PART NAME	PART NUMBER	QTY	CHK'D BY	VERF'D BY
6.9	Ø7.0" Vane Axial Blower	IFSS 050084-7-3	1		
6.10	Condenser Exhaust Assembly	520001	1		
6.11	Condenser Exhaust Tube	250444	1		
6.12	7-8" Band Clamp	060038	1		
6.14	Air Inlet Screen	080040	1		
6.14	Camloc	2600-9	6		
7.1	Nutplate Strip Assy. Fwd. Evap.	510373	1		
7.1	Rivet	CR3212-4-03	2		
7.2	Fwd Evaporator Assy	560004	1		
7.2	Fwd Evaporator Mount Shim	261357	1		
7.2	Bolt	AN3-5A	5		
7.2	Washer	AN960-10	5		
7.3	Fwd Evap. Support Vertical Member	260486-1	1		
7.3	Rivet	CR3212-4-03	2		
7.5	Bolt	AN3-4A	3		
7.5	Nut	MS21044N3	3		
7.5	Washer	AN960-10	6		
7.6	Fwd. Evap. Support Assy., Upper	510379	1		
7.6	Bolt	AN3-3A	2		
7.6	Washer	AN960-10	4		
7.6	Fwd. Evap. Support Assy., Lower	510380	1		
7.7	Washer	AN970-3	2		
7.7	Bolt	AN3-3A	2		
7.7	Nut	MS21044N3	2		
7.7	Washer	AN960-10	2		



Kit Configuration Inventory List

STEP	PART NAME	PART NUMBER	QTY	CHK'D BY	VERF'D BY
7.12	Air Outlet Mount, Left Side (Config. -01)	250447	1		
7.12	Vent Mount (Config. -02)	261335HP	1		
7.14	Bolt (Config. -01)	AN3-4A	1		
7.14	Washer (Config. -01)	AN970-3	2		
7.14	Nut (Config. -01)	MS21083-N3	1		
7.14	Screw (Config. -02)	AN525-832R8	2		
7.14	Nut (Config. -02)	MS21042L08	2		
7.15	Rivnut (Config. -01)	A10K80	3		
7.15	Screw (Config. -01)	AN525-10R7	3		
7.15	Left Side Air Outlet Assembly (Config. -01)	500001	1		
7.15	Air Vent Assy. L.H. (Config. -02)	520156HP	1		
7.15	Screw (Config. -02)	AN525-832R8	1		
7.16	Air Outlet Mount, Right Side (Config. -01)	250448	1		
7.16	Vent Mount (Config. -02)	261335HP	1		
7.18	Bolt (Config. -01)	AN3-4A	1		
7.18	Washer (Config. -01)	AN970-3	2		
7.18	Nut (Config. -01)	MS21083-N3	1		
7.18	Screw (Config. -02)	AN525-832R8	2		
7.18	Nut (Config. -02)	MS21042L08	2		
7.19	Rivnut (Config. -01)	A10K80	3		
7.19	Screw (Config. -01)	AN525-10R7	3		
7.19	Right Air Outlet Assembly (Config. -01)	500002	1		
7.19	Air Vent Assy. R.H. (Config. -02)	520157HP	1		
7.19	Screw (Config. -02)	AN525-832R8	1		
7.20	3" Band Clamp	060036	2		
7.21	Inner Closeout Skirt	110018	1		
7.21	Outer Closeout Skirt	110019	1		



Kit Configuration Inventory List

STEP	PART NAME	PART NUMBER	QTY	CHK'D BY	VERF'D BY
8.5	4 Groove Belt***	060005	2		
8.5	Smooth Belt*** (Alt. P/N: 060018)	060018-1	2		
8.6	Cotter Pin	MS24665-151	6		
8.9	Compressor Bracket kit	SEE PAGE 14	1		
8.10	SD-507 Compressor Assy.(Grooved)***	590008-1	1		
8.10	SD-507 Compressor Assy.(Smooth)***	590008	1		
9.1	Electric Box Shelf	261375	1		
9.2	Electrical Box Assembly	540009	1		
9.3	Screw	AN525-10R6	3		
9.4	Harness Assembly	540010	1		
9.4	Ring Terminal 12 - 10 x 1/4	AP35110	2		
9.5	Harness Assembly	540045-1	1		
9.5	Ring Terminal 8 GA #10	050020-9	1		
9.5	Limiter 50 AMP	ANL-50	1		
9.7	Battery Comp. Shelf Angle Fwd. Assy.	510265	2		
9.7	Battery Comp. Shelf Angle Fwd.	260335	2		
9.7	Bolt	AN3-3A	10		
9.7	Nut	MS21044N3	4		
9.7	Washer	AN960-10	18		



Kit Configuration Inventory List

STEP	PART NAME	PART NUMBER	QTY	CHK'D BY	VERF'D BY
9.8	Switch Assembly*** (Config. -01 for non-microswitch Config. -02 for microswitch)	540011	1		
9.8	Panel Mount Switch Assembly*** (optional non-microswitch switch assy.)	540012	1		
10.1	Mount Plate Assembly	510381	1		
10.1	Screw	AN525-10R7	4		
10.1	Washer	AN960-10	8		
10.1	Nut	MS21044N3	4		
10.1	3" Band Clamp	060036	1		
10.1	Receiver/Drier	090016-5	1		
10.2	#6 'O' Ring	090092	5		
10.2	#8 'O' Ring	090093	3		
10.2	#10 'O' Ring	090094	3		
10.3	Return Hose #10 Assembly	570105-01	1		
10.3	Hose Disconnect Bracket	04-130-21-107-01	2		
10.4	High Pressure Hose, #6 Assembly	570103	1		
10.5	1" Band Clamp	060037	1		
10.5	Cork Insulation Tape	070078-O	6 ft.		
10.6	Hose Assembly #8 Comp. Discharge	570070-"O"-A	1		
10.7	Cond. to Rec/Drier Hose, #6 Assy.	570104	1		



Kit Configuration Inventory List

PART NAME	PART NUMBER	QTY	CHK'D BY	VERF'D BY
7" Tie Wraps (packs of 100)	MS3367-1-0	3		
Tie Blocks	ZZCR4HM	50		
Adel Clamps	MS21919WDG12	9		
Spiral Wrap	SW12BKV	24' ft.		
Grommet	MS35489-20	2		
Foam Insulation Tape	070078	20' ft.		
Low Pressure Switch	050107	1		
High Pressure Switch	090004	1		
Hand Shake Splice (16-14)	050020-1	14		
Ring Terminal 16-14 #10	050020-8	10		
Drain Hose 1/2"	090018-1	10' ft.		
Bolt	AN3-4A	4		
Bolt	AN3-5A	4		
Bolt	AN4-6A	8		
Screw	AN525-10R8	4		
Washer	AN960-10	8		
Washer	AN960-416L	24		
Rivets	MS20470AD4-3	5		
Nut	MS21083-N3	4		
Clamp	MS21919WDG11	1		
EMI Filter *** (optional - for brushless motors)				
EMI Filter	13619-RF16883	2		
Screw	MS27039-0807	4		
Washer	NAS620-8L	4		

*** Indicates it has alternate or optional configuration.



DRAWING LIST

DRAWING NAME	DRAWING #	QTY	CHK'D BY	VERF'D BY
AIR CONDITIONING OVERVIEW	1-1-EC130	1		
ELECTRICAL ROUTING	2-1-EC130	1		
ELECTRICAL DIAGRAM (SHEET 1 OF 2)	2-3-EC130	1		
ELECTRICAL DIAGRAM (SHEET 2 OF 2)	2-3-EC130	1		
PLUMBING DIAGRAM	3-1-EC130	1		
PLUMBING ROUTING	3-2-EC130	1		
AFT EVAPORATOR INSTALL (SHEET 1 OF 2)	4-1-EC130	1		
AFT EVAPORATOR INSTALL (SHEET 2 OF 2)	4-1-EC130	1		
AFT EVAPORATOR INSTALL	4-2-EC130	1		
EVAPORATOR INSTALL, FWD (SHEET 1 OF 2)	4-3-EC130	1		
EVAPORATOR INSTALL, FWD (SHEET 2 OF 2)	4-3-EC130	1		
FWD DRAIN HOSE INSTALL	4-4-EC130	1		
AIR DISTRIBUTION	5-1-EC130	1		
AIR DISTRIBUTION	5-2-EC130	1		
AIR DISTRIBUTION	5-3-EC130	1		
PANEL MOUNT SWITCH INSTL	5-4-EC130	1		
COMPRESSOR INSTALLATION	6-1-EC130	1		
COMPRESSOR INSTALLATION	6-2-EC130	1		
COMPRESSOR INSTALLATION	6-3-EC130	1		
BELT TENSION	6-5-EC130	1		
COMPRESSOR INSTALLATION (AS350)	6-2-AS350***	1		
COMPRESSOR INSTALLATION (AS350 – 4 PAGES)	6-3-AS350***	1		
AFT CONDENSER INSTALLATION	7-1-EC130	1		
AFT CONDENSER EXHAUST INSTALLATION	7-2-EC130	1		
INSTALLATION, AIR INLET DOUBLER	7-3-EC130	1		
ELECTRICAL BOX, SHELF INSTALLATION	8-1-EC130	1		
ELECTRICAL BOX INSTALLATION	8-2-EC130	1		

****Indicates referenced drawing*



DOCUMENT LIST

DOCUMENT DESCRIPTION	LOCATION	QTY	CHK'D BY	VERF'D BY
KIT CONFIGURATION INVENTORY LIST (IFS 33.41)	SECTION 1	1		
MAT'L SAFETY DATA SHEETS	SECTION 1	1 EA.		
AIRCRAFT PRE-INSPECTION	SECTION 2	1		
AIRCRAFT PREPERATION	SECTION 3	1		
REMOVAL OF FACTORY INSTALLED COMPONENTS	SECTION 4	1		
INSTALLATION OF AFT EVAPORATOR	SECTION 5	1		
INSTALLATION OF CONDENSER	SECTION 6	1		
INSTALLATION OF FORWARD EVAPORATOR	SECTION 7	1		
INSTALLATION OF COMPRESSOR	SECTION 8	1		
INSTALLATION OF ELECTRICAL	SECTION 9	1		
INSTALLATION OF HOSES	SECTION 10	1		
STC# SH3509SW	SECTION 11	1		
WEIGHT AND BALANCE	SECTION 11	1		
RFMS FOR AS350B, BA, B1, B2, B3, C, D AND D1	SECTION 11	1 EA.		
FOREIGN APPVS, CANADIAN, ANAC AND EASA	SECTION 11	1 EA.		
INSTRUCTIONS FOR CONTINUED AIRWORTHINESS	SECTION 12	1		
MASTER PARTS LIST	SECTION 13	1		
ILLUSTRATED PARTS CATALOG	SECTION 13	1		
WARRANTY AND REPAIR	SECTION 14	1		
TROUBLE SHOOTING GUIDE	SECTION 15	1		
AIR CONDITIONING PERFORMANCE CHECK	SECTION 15	1		



COMPRESSOR BRACKET INSTALLATION KIT

ITEM DESCRIPTION	Part Number	QTY	Comment	CHK'D BY	VERF'D BY
COMPRESSOR MOUNT BRACKET	04-130-21-101-01	1			
COMPRESSOR MOUNT TENSION BOLT	04-130-21-102-01	1			
JAM NUT DRILLED	04-130-21-104-01	2			
COMPRESSOR CLAMP	04-130-21-105-01	2			
BUSHING, SD 507	261007	2			
COMPRESSOR STAND OFF	300067-1	1			
SHIM	300363-2	2			
THREADED ROD END	2434K39	1			
PIN	300095	1			
STRAP HOUSING	530100-1	1			
WASHER	NAS1149D0416H	1	Or NAS Hardware equivalent		
WASHER	NAS1149D0632H	6	Or NAS Hardware equivalent		
WASHER	NAS1149D0532H	2	Or NAS Hardware equivalent		
WASHER	AN960-416	4	Alternate (NAS1149F0463P)		
WASHER	AN960-516L	1	Alternate (NAS1149F0532P)		
WASHER	AN960-616L	2	Alternate (NAS1149F0632P)		
NUT	MS21042-L5	2	Alternate (MS20364-524C)		
NUT	MS21042-L4	3	Alternate (AN365-424)		
NUT	MS21042L6	4	Or NAS Hardware equivalent		
BOLT	AN4-5A	1	Or NAS Hardware equivalent		
BOLT	AN4-14A	2	Or NAS Hardware equivalent		
BOLT	AN5-34A	1	Or NAS Hardware equivalent		
BOLT	AN6-13A	2	Or NAS Hardware equivalent		
BOLT HEX DRIVE	AN6-12	1	Or NAS Hardware equivalent		
BOLT	AN6-33A	1	Or NAS Hardware equivalent		

THIS INFORMATION PERTAINS TO:
 IFS PN: 070003 TOUCH UP PAINT - TEAL
 IFS PN: 070003-1 TOUCH UP PAINT-GREY

Material Safety Data Sheet
 acc. to ISO/DIS 11014



Reviewed on 02/07/2005

Printing date 07/28/2005

1 Identification of substance

· **Product details**

· **Trade name:** 61003 Multi-Coat Blank Aerosol

· **Article number:** 61003

· **Manufacturer/Supplier:**

SEM Products, Inc.
 651 Michael Wylie Dr.
 Charlotte, NC 28217
 USA
 (704)522-1006

· **Information department:** 24HR EMERGENCY CHEMTREC 800-424-9300

2 Composition/Data on components

· **Chemical characterization**

· **Description:** Mixture of the substances listed below with nonhazardous additions.

· **Dangerous components:**

67-64-1	acetone	50-100%
74-98-6	propane	10-25%
78-93-3	butanone	2.5-10%

3 Hazards identification

· **Hazard description:**



Irritant
 Extremely flammable

· **Information pertaining to particular dangers for man and environment:**

The product has to be labelled due to the calculation procedure of international guidelines.

Warning! Pressurized container.

Has a narcotizing effect.

Extremely flammable.

Irritating to eyes, respiratory system and skin.

Vapours may cause drowsiness and dizziness.

Pressurized container: protect from sunlight and do not expose to temperatures exceeding 50°C, i.e. electric lights. Do not pierce or burn, even after use.

100.0 % by mass of the contents are flammable

Keep out of the reach of children.

· **Classification system:**

The classification was made according to the latest editions of international substances lists, and expanded upon from company and literature data.

· **NFPA ratings (scale 0 - 4)**



Health = 2
 Fire = 4
 Reactivity = 0

(Contd. on page 2)



Trade name: 61003 Multi-Coat Blank Aerosol

(Contd. of page 1)

· **HMIS-ratings (scale 0 - 4)**

HEALTH	2	Health = 2
FLAMMABILITY	4	Fire = 4
REACTIVITY	0	Reactivity = 0

4 First aid measures

- **After inhalation:** In case of unconsciousness place patient stably in side position for transportation.
- **After skin contact:** Immediately wash with water and soap and rinse thoroughly.
- **After eye contact:**
Rinse opened eye for several minutes under running water. If symptoms persist, consult a doctor.
- **After swallowing:** If symptoms persist consult doctor.

5 Fire fighting measures

- **Suitable extinguishing agents:** CO₂, sand, extinguishing powder. Do not use water.
- **For safety reasons unsuitable extinguishing agents:** Water with full jet
- **Protective equipment:** No special measures required.

6 Accidental release measures

- **Person-related safety precautions:** Wear protective equipment. Keep unprotected persons away.
- **Measures for environmental protection:** Do not allow to enter sewers/ surface or ground water.
- **Measures for cleaning/collecting:**
Ensure adequate ventilation.
Do not flush with water or aqueous cleansing agents

7 Handling and storage

- **Handling:**
- **Information for safe handling:**
Open and handle receptacle with care.
- **Information about protection against explosions and fires:**
Do not spray on a naked flame or any incandescent material.
Keep ignition sources away - Do not smoke.
Protect against electrostatic charges.
Pressurized container: protect from sunlight and do not expose to temperatures exceeding 50°C, i.e. electric lights. Do not pierce or burn, even after use.
- **Storage:**
- **Requirements to be met by storerooms and receptacles:**
Store in a cool location.
Observe official regulations on storing packagings with pressurized containers.
- **Information about storage in one common storage facility:** Not required.
- **Further information about storage conditions:**
Keep receptacle tightly sealed.
Do not gas tight seal receptacle.
Store in cool, dry conditions in well sealed receptacles.

(Contd. on page 3)

**Trade name:** 61003 Multi-Coat Blank Aerosol

(Contd. of page 2)

Protect from heat and direct sunlight.

8 Exposure controls and personal protection

- Additional information about design of technical systems: No further data; see item 7.

- Components with limit values that require monitoring at the workplace:

67-64-1 acetone

PEL () 2400 mg/m³, 1000 ppm
 REL () 590 mg/m³, 250 ppm
 TLV () Short-term value: 1782 mg/m³, 750 ppm
 Long-term value: 1188 mg/m³, 500 ppm
 BEI

74-98-6 propane

PEL () 1800 mg/m³, 1000 ppm
 REL () 1800 mg/m³, 1000 ppm
 TLV () (4508) mg/m³, (2500) ppm

78-93-3 butanone

PEL () 590 mg/m³, 200 ppm
 REL () Short-term value: 885 mg/m³, 300 ppm
 Long-term value: 590 mg/m³, 200 ppm
 TLV () Short-term value: 885 mg/m³, 300 ppm
 Long-term value: 590 mg/m³, 200 ppm
 BEI

- Additional information: The lists that were valid during the creation were used as basis.

- Personal protective equipment:

- General protective and hygienic measures:

Keep away from foodstuffs, beverages and feed.
 Immediately remove all soiled and contaminated clothing.
 Wash hands before breaks and at the end of work.
 Avoid contact with the eyes and skin.

- Breathing equipment:

In case of brief exposure or low pollution use respiratory filter device. In case of intensive or longer exposure use respiratory protective device that is independent of circulating air.
 Use suitable respiratory protective device in case of insufficient ventilation.

- Protection of hands:



Protective gloves

The glove material has to be impermeable and resistant to the product/ the substance/ the preparation.
 Due to missing tests no recommendation to the glove material can be given for the product/ the preparation/ the chemical mixture.

Selection of the glove material on consideration of the penetration times, rates of diffusion and the degradation

- Material of gloves

The selection of the suitable gloves does not only depend on the material, but also on further marks of quality and varies from manufacturer to manufacturer. As the product is a preparation of several substances, the resistance of the glove material can not be calculated in advance and has therefore to be checked prior to the application.

- Penetration time of glove material

The exact break through time has to be found out by the manufacturer of the protective gloves and has to be observed.

(Contd. on page 4)

THIS INFORMATION PERTAINS TO:
 IFS PN: 070003 TOUCH UP PAINT - TEAL
 IFS PN: 070003-1 TOUCH UP PAINT-GREY

Material Safety Data Sheet
 acc. to ISO/DIS 11014



Reviewed on 02/07/2005

Printing date 07/28/2005

Trade name: 61003 Multi-Coat Blank Aerosol

(Contd. of page 3)

· Eye protection:



Tightly sealed goggles

9 Physical and chemical properties

· General Information

Form: Aerosol
Color: According to product specification
Odor: Characteristic

· Change in condition

Melting point/Melting range: Undetermined.
Boiling point/Boiling range: < 0°C (< 32°F)

· **Flash point:** < 0°C (< 32°F)

· **Ignition temperature:** 465.0°C (869°F)

· **Auto igniting:** Product is not selfigniting.

· **Danger of explosion:**· **Explosion limits:**

Lower: 1.7 Vol %
Upper: 13.0 Vol %

· **Vapor pressure at 20°C (68°F):** 8300.0 hPa (6226 mm Hg)

· **Density at 20°C (68°F):** 0.70 g/cm³

· Solubility in / Miscibility with

Water: Not miscible or difficult to mix.

· Solvent content:

Organic solvents: 99.0 %
VOC content: 34.0 %
 243.6 g/l / 2.03 lb/gal

10 Stability and reactivity

- **Thermal decomposition / conditions to be avoided:** No decomposition if used according to specifications.
- **Dangerous reactions** No dangerous reactions known.
- **Dangerous products of decomposition:** No dangerous decomposition products known.

11 Toxicological information

· Acute toxicity:

· **LD/LC50 values that are relevant for classification:**

67-64-1 acetone

Oral	LD50	5800 mg/kg (rat)
Dermal	LD50	20000 mg/kg (rabbit)

(Contd. on page 5)

THIS INFORMATION PERTAINS TO:
 IFS PN: 070003 TOUCH UP PAINT - TEAL
 IFS PN: 070003-1 TOUCH UP PAINT-GREY

Material Safety Data Sheet
acc. to ISO/DIS 11014



Printing date 07/28/2005

Reviewed on 02/07/2005

Trade name: 61003 Multi-Coat Blank Aerosol

(Contd. of page 4)

- **Primary irritant effect:**
- *on the skin:* Irritant to skin and mucous membranes.
- *on the eye:* Irritating effect.
- **Sensitization:** No sensitizing effects known.
- **Additional toxicological information:**
 The product shows the following dangers according to internally approved calculation methods for preparations:
 Irritant

12 Ecological information

- **General notes:**
 Water hazard class 3 (Self-assessment): extremely hazardous for water
 Do not allow product to reach ground water, water course or sewage system, even in small quantities.
 Danger to drinking water if even extremely small quantities leak into the ground.

13 Disposal considerations

- **Product:**
- **Recommendation:**
 Must not be disposed of together with household garbage. Do not allow product to reach sewage system.
- **Uncleaned packagings:**
- **Recommendation:** Disposal must be made according to official regulations.

14 Transport information

- **DOT regulations:**



- **Hazard class:** 2.1
- **Identification number:** UN1950
- **Packing group:** -
- **Proper shipping name (technical name):** AEROSOLS, flammable
- **Label:** 2.1

- **Land transport ADR/RID (cross-border):**



- **ADR/RID class:** 2 5F Gases
- **Danger code (Kemler):** 23
- **UN-Number:** 1950
- **Packaging group:** -
- **Label:** 2.1

(Contd. on page 6)

THIS INFORMATION PERTAINS TO:
 IFS PN: 070003 TOUCH UP PAINT - TEAL
 IFS PN: 070003-1 TOUCH UP PAINT-GREY

Material Safety Data Sheet
 acc. to ISO/DIS 11014



Printing date 07/28/2005

Reviewed on 02/07/2005

Trade name: 61003 Multi-Coat Blank Aerosol

(Contd. of page 5)

· **Description of goods:** 1950 AEROSOLS

· **Maritime transport IMDG:**



· **IMDG Class:** 2.1
 · **UN Number:** 1950
 · **Label** 2.1
 · **Packaging group:** -
 · **EMS Number:** F-D,S-U
 · **Marine pollutant:** No
 · **Propper shipping name:** AEROSOLS

· **Air transport ICAO-TI and IATA-DGR:**



· **ICAO/IATA Class:** 2.1
 · **UN/ID Number:** 1950
 · **Label** 2.1
 · **Packaging group:** -
 · **Propper shipping name:** AEROSOLS, flammable

15 Regulations

· **Sara**

· **Section 355 (extremely hazardous substances):**

None of the ingredient is listed.

· **Section 313 (Specific toxic chemical listings):**

78-93-3 butanone

· **TSCA (Toxic Substances Control Act):**

All ingredients are listed.

· **Proposition 65**

· **Chemicals known to cause cancer:**

None of the ingredients is listed.

· **Chemicals known to cause reproductive toxicity:**

None of the ingredients is listed.

· **Cancerogenity categories**

· **EPA (Environmental Protection Agency)**

67-64-1 acetone

D

78-93-3 butanone

D

· **IARC (International Agency for Research on Cancer)**

None of the ingredients is listed.

(Contd. on page 7)

THIS INFORMATION PERTAINS TO:
 IFS PN: 070003 TOUCH UP PAINT - TEAL
 IFS PN: 070003-1 TOUCH UP PAINT-GREY

Material Safety Data Sheet
 acc. to ISO/DIS 11014



Printing date 07/28/2005

Reviewed on 02/07/2005

Trade name: 61003 Multi-Coat Blank Aerosol

(Contd. of page 6)

NTP (National Toxicology Program)

None of the ingredients is listed.

TLV (Threshold Limit Value established by ACGIH)

67-64-1 acetone

A4

NIOSH-Ca (National Institute for Occupational Safety and Health)

None of the ingredients is listed.

OSHA-Ca (Occupational Safety & Health Administration)

None of the ingredients is listed.

Product related hazard informations:

The product has been classified and marked in accordance with directives on hazardous materials.

Hazard symbols:

Irritant

Extremely flammable

Risk phrases:

Extremely flammable.

Irritating to eyes, respiratory system and skin.

Vapours may cause drowsiness and dizziness.

Safety phrases:

Keep in a cool place.

Keep container in a well-ventilated place.

Use only in well-ventilated areas.

This material and its container must be disposed of as hazardous waste.

Special labeling of certain preparations:

Pressurized container: protect from sunlight and do not expose to temperatures exceeding 50°C, i.e. electric lights. Do not pierce or burn, even after use.

100.0 % by mass of the contents are flammable

Keep out of the reach of children.

16 Other information

This information is based on our present knowledge. However, this shall not constitute a guarantee for any specific product features and shall not establish a legally valid contractual relationship.

Department issuing MSDS: Environment protection department.

Contact: Mr. George Wallace

MATERIAL SAFETY DATA SHEET

Trade Name: Johnsen's Ester 100
MSDS NO. 6711
Revision Date: 03/26/2007
Date Printed: 12/30/2008

1. CHEMICAL PRODUCT AND COMPANY IDENTIFICATION

Trade Name: Johnsen's Ester 100
Chemical Family: Refrigeration Oil
Synonyms: None
Emergency Telephone (24 hr.): CHEMTREC 1-800-424-9300

Supplier: Technical Chemical Company, P.O. Box 139, Cleburne, Texas 76033

2. COMPOSITION/INFORMATION ON INGREDIENTS

Component	Weight %	OSHA TWA	OSHA STEL	OSHA SKIN
Ester Proprietary Inhibitor Package Mixture	0-20	Not Listed	Not Listed	Not Listed
Ester Proprietary Base Stock Mixture	20-80	Not Listed	Not Listed	Not Listed

Component	Weight %	OSHA Z PEL	OSHA Z TWA	OSHA Z Ceiling
Ester Proprietary Inhibitor Package Mixture	0-20	Not Listed	Not Listed	Not Listed
Ester Proprietary Base Stock Mixture	20-80	Not Listed	Not Listed	Not Listed

Component	ACGIH TLV TWA	ACGIH TLV STEL	ACGIH TLV Ceiling
Ester Proprietary Inhibitor Package Mixture	Not Listed	Not Listed	Not Listed
Ester Proprietary Base Stock Mixture	Not Listed	Not Listed	Not Listed

Other: Contains no ingredients in concentrations greater than 0.1% that are now known to be hazardous as defined by OSHA.

3. HAZARDS IDENTIFICATION

Emergency Overview: Ingestion of this product may cause gastrointestinal distress with symptoms of nausea, vomiting, diarrhea and abdominal pain. May cause irritation to skin and eyes.

HMIS Classification: Health: 1 Flammability: 1 Physical Hazard: 0
NFPA Rating: Health: 1 Flammability: 1 Reactivity: 0

4. FIRST AID MEASURES

Eye Contact: In case of contact, immediately flush eyes with plenty of water for at least 15 minutes, occasionally lifting the upper and lower lids. Seek medical attention if irritation persists.
Ingestion: DO NOT INDUCE VOMITING. Give nothing by mouth. Get medical attention! If vomiting occurs, keep head lower than hips to prevent aspiration.
Inhalation: If inhaled, remove to fresh air. If not breathing give artificial respiration, preferably mouth-to-mouth. If breathing is difficult give oxygen. Get medical attention.
Skin Contact: Remove contaminated clothing and shoes, and launder before reuse. Get medical attention if irritation persists. Wash with soap and water. Use skin cream for defatted areas.

MATERIAL SAFETY DATA SHEET

Trade Name: Johnsen's Ester 100
MSDS NO. 6711
Revision Date: 03/26/2007
Date Printed: 12/30/2008

5. FIRE FIGHTING MEASURES

Flammable Properties

Flash Point °F(°C): >482 (<250)
Flash Point Method: COC
Flammable Limits in Air - Lower (%): Not Determined
Flammable Limits in Air - Upper (%): Not Determined
Autoignition Temperature °F(°C): Not Determined
Extinguishing Media: Carbon dioxide. Dry chemical. Foam.
Protection Of Fire-Fighters:

Special Fire-Fighting Procedures: Wear approved positive-pressure self-contained breathing apparatus and protective clothing. Do not direct a solid stream of water or foam into hot, burning pools; this may cause frothing and increase fire intensity.
Hazardous Combustion Products: Oxides of carbon, nitrogen and phosphorus.
Aerosol Comments: Not Applicable

6. ACCIDENTAL RELEASE MEASURES

Personal Precautions: Wear appropriate protective clothing and equipment to prevent skin and eye contact.
Spill Procedures: Wear protective equipment specified. Contain any liquid from leaking containers.
Action to be taken if material is released or spilled: Absorb spills on inert material such as perlite, vermiculite, sand or dirt. Place in double polyethylene bags. Isolate from other waste materials. Wash walking surfaces with detergent and water to reduce slipping hazard.
Environmental Precautions: Do not allow to enter sanitary drains, sewer or surface and subsurface waters.

7. HANDLING AND STORAGE

Handling and Storage: Avoid contact with eyes. Keep containers tightly closed when not in use. Use only in a well ventilated area. Good hygienic practices should be observed. Work clothes should be washed separately at the end of each work day. Contaminated disposable clothing should be discarded in accordance with local, state and federal rules. Wash thoroughly after handling. Do Not Swallow. Store at room temperature. Avoid prolonged/repeated breathing of vapors, mists or fumes.

8. EXPOSURE CONTROLS/PERSONAL PROTECTION

Engineering Controls: Eyewash stations. Showers. Use local exhaust.
Eyes: Chemical goggles; also wear a face shield if splashing hazard exists.
Skin Protection: Neoprene coated apron or clothing.
Respiratory Protection: Appropriate respiratory protection shall be worn when applied engineering controls are not adequate to protect against inhalation exposure.

9. PHYSICAL AND CHEMICAL PROPERTIES

Appearance: Clear to light yellow liquid
Odor: MILD ETHER
pH Value: Not Determined
Vapor Pressure: Not Determined
Vapor Density (Air=1): Not Determined
Boiling Point (°F): >300 C.
Melting/Freezing Point: Not Determined
Solubility in Water: INSOLUBLE
Bulk Density at 20°C: Not Determined
Molecular Weight: Mixture
Specific Gravity (H2O=1): 1.04 @ 60F
Viscosity: 100 cSt @ 40C
Evaporation Rate: Not Determined
VOC Content(%): Not determined.
Decomposition Temperature: Not Known

MATERIAL SAFETY DATA SHEET

Trade Name: Johnsen's Ester 100
MSDS NO. 6711
Revision Date: 03/26/2007
Date Printed: 12/30/2008

10. STABILITY AND REACTIVITY

Chemical Stability: Stable under normal conditions of handling, use and transportation.
Conditions to Avoid: High temperatures.
Materials to Avoid: Strong oxidizing agents.
Hazardous Decomposition Products: Oxides of nitrogen. Oxides of carbon. Oxides of sulfur.
Hazardous Polymerization: WILL NOT OCCUR

11. TOXICOLOGICAL INFORMATION

Toxicological Data:

Component	Route	Species	Dose
Ester Proprietary Inhibitor Package Mixture	Inhalation	Rats	Not known.
Ester Proprietary Base Stock Mixture	Inhalation	Rats	Not known.

Carcinogenicity:

Component	IARC	NTP	OSHA
Ester Proprietary Inhibitor Package Mixture	Not Listed	Not Listed	Not Listed
Ester Proprietary Base Stock Mixture	Not Listed	Not Listed	Not Listed

Comments: No component known to be present in this product at >.1% is presently listed as a carcinogen by IARC, NTP or OSHA.

12. ECOLOGICAL INFORMATION

Remarks: Ecological testing has not been conducted on this product.

13. DISPOSAL CONSIDERATION

Waste Classification: This product as purchased does not fall under current U.S. EPA RCRA definitions of hazardous waste. Under RCRA it is the generator's responsibility to determine the status of the waste at the time of its disposal. This product does not contain any CERCLA regulated materials.
Waste Management: Not determined.
Disposal Method: Disposal of this material to the land may be banned by federal law (40 CFR 268).

14. TRANSPORTATION INFORMATION

U.S. DOT:
Proper Shipping Name: Not Regulated
Hazard Class: Not Applicable
UN/NA Number: Not Applicable
DOT Packing Group: Not Applicable

IMDG:
Proper Shipping Name: Not Regulated
Hazard Class: Not Applicable
Hazard Subclass: Not Applicable
UN No.: Not Applicable
Packing Group: Not Applicable
Marine Pollutant: No

MATERIAL SAFETY DATA SHEET

Trade Name: Johnsen's Ester 100
 MSDS NO. 6711
 Revision Date: 03/26/2007
 Date Printed: 12/30/2008

15. REGULATORY INFORMATION

US Federal Regulations:

Component	SARA 313	SARA 302	TPQ	RQ
Ester Proprietary Inhibitor Package Mixture	Not Listed	Not Listed	Not Listed	Not Listed
Ester Proprietary Base Stock Mixture	Not Listed	Not Listed	Not Listed	Not Listed

US OSHA HEALTH CLASSIFICATION: Hazardous per OSHA 29 CFR 1910.1200
SARA 311/312 Hazard Categories: Immediate Health: Yes, Delayed Health: No, Fire: No, Reactive: No, Pressure: No.

State Regulations:

Component	California Prop. 65 Cancer list	California - Prop 65 Developmental Toxicity	California Prop. 65 Reproductive Female	California Prop. 65 Reproductive Male
Ester Proprietary Inhibitor Package Mixture	Not Listed	Not Listed	Not Listed	Not Listed
Ester Proprietary Base Stock Mixture	Not Listed	Not Listed	Not Listed	Not Listed

U.S. TSCA: One or more components of this product is not listed on the TSCA Inventory.
Canadian Inventory: One or more components of this product is not listed on the Canadian DSL or NDSL Inventory.

Consumer Product Safety Improvement Act of 2008 General Conformity Certification

The Supplier identified in Section 1 of this MSDS has evaluated this product and certifies it to be labeled and packaged in compliance with the applicable provisions of the Federal Hazardous Substance Act as stated in 16 CFR 1500 and enforced by the Consumer Product Safety Commission, and where applicable the products that require Child Resistant Closures are packaged in accordance with the Poison Prevention Packaging Act as stated in 16 CFR 1700 and enforced by the Consumer Product Safety Commission. All closures have been tested in accordance with the latest protocols. No other testing is required to certify compliance with the above. The date of manufacture is stamped on the product container.

16. OTHER INFORMATION

General Notes:
Disclaimer: Do not allow undiluted material or large quantities to reach groundwater, bodies of water or sewer system. The information and recommendations contained herein are based upon tests believed to be reliable. However, the manufacturer/distributor of this product does not guarantee their accuracy or completeness NOR SHALL ANY OF THIS INFORMATION CONSTITUTE A WARRANTY, WHETHER EXPRESSED OR IMPLIED, AS TO THE SAFETY OF THE GOODS, THE MERCHANTABILITY OF THE GOODS, OR THE FITNESS OF THE GOODS FOR A PARTICULAR PURPOSE. Adjustment to conform to actual conditions of usage may be required. The manufacturer/distributor assumes no responsibility for results obtained or for incidental or consequential damages, including lost profits, arising from the use of these data. No warranty against infringement of any patent, copyright or trademark is made or implied.

Step 2

Aircraft Pre-Inspection

Aircraft Pre-Inspection

STEP	PROCEDURE	MECH	INSP
2.1	Inspect the aircraft for other kits and Modifications that may effect the installation of The air conditioning kit.		
2.2	Inspect the airframe structure for any obvious Structural damage or corrosion.		
2.3	Repair discrepancies that are found prior to Installation of kit.		
2.4	Inspect aircraft paperwork for damage history that may effect the installation of this kit.		

General Safety Instructions

STEP	PROCEDURE	Mech	Insp
	<u>WARNING:</u> Always handle the refrigerant fluids carefully.		
	<u>WARNING:</u> Do not mix other refrigerant fluids with the R134a. Do not use refrigerant canned for pressure-operated accessories (such as boat air horns). This refrigerant is not pure and will cause malfunctions in the system.		
	<u>WARNING:</u> When the system must be opened to do maintenance, before you do the work, you must drain the air conditioning system.		
	<u>WARNING:</u> When you open the system, you must collect the refrigerant in accordance with Federal and Local regulations.		
	<u>WARNING:</u> When the R134a is used in normal conditions, it is not flammable. Do not use it near a source of heat to prevent the risk of separation of the vapors.		
	<u>WARNING:</u> Avoid skin and eye contact with R-134a. The liquid R-134a, at normal atmospheric temperatures evaporates so quickly that it will freeze anything it comes in contact with.		
	<u>WARNING:</u> Wear safety goggles when servicing any part of the refrigerant system.		
	<u>WARNING:</u> Never heat a R-134a supply cylinder to produce additional pressure or attempt to empty the container completely.		
	<u>WARNING:</u> Insure adequate ventilation when servicing the refrigerant system.		
	<u>WARNING:</u> If the R-134a and lubrication oil are mixed with water they make hydrochloric acid. This will cause corrosion of the system components.		

General Safety Instructions

STEP	PROCEDURE	Mech	Insp
	<u>WARNING:</u> You must replace the filter drier each time you open the system.		
	<u>WARNING:</u> Comply with the regulations in force in the country where the aircraft is operated when working on the air conditioning system.		
	<u>WARNING:</u> Only use nitrogen or Alcohol to clean the system components.		
	<u>WARNING:</u> Always keep the R-134a supply cylinder in an upright position when admitting refrigerant into the system. If a cylinder is on its side or upside down, liquid will enter the R-134a system and cause damage to the compressor.		

Step 3

Aircraft Preparation

Aircraft Preparation

STEP	PROCEDURE	MECH	INSP
3.0	Remove or disconnect the battery.		
3.1	Remove pilot and co-pilots doors.		
3.2	Remove right rear door as needed.		
3.3	Remove rear seats.		
3.4	Remove rear seat pallets.		
3.5	Drop the cabin headliner.		
3.6	Remove the two side screws from both sides of the glare shield.		
3.7	Remove back wall covering.		
3.8	Remove the right side baggage door.		
3.9	Remove the forward closeout panel in the right hand baggage compartment.		
3.10	Remove the tail boom left hand access panel (rectangle).		
3.11	Remove the tail boom left hand access panel (rectangle).		
3.12	Remove the right hand transmission cowling.		
3.13	Remove the left hand transmission cowling.		
3.14	Remove lower nose right window.		
3.15	Remove the front belly cowling.		
3.15a	Remove the center front belly cowling.		
3.15b	Remove the right middle belly cowling.		
3.15c	Lower the rear belly cowling.		

Aircraft Preparation

STEP	PROCEDURE	MECH	INSP
3.16	Remove the cargo net from the rear baggage compartment. (If installed)		
3.17	Remove the rear cargo compartment floor.		
3.18	Remove the electrical compartment cover. NOTE: Determine location for air conditioning power hook up. Reinstall cover to prevent FOD.		
3.19	Remove the rear cargo compartment forward floor panel.		
<u>NOTE:</u> After installation of system, a thorough inspection of all areas affected must be performed to determine security component installations and workman-ship standards prior to reassembly of aircraft and return to service by a qualified individual.			

Step 4

Removal of Factory Installed Components

Removal of Factory Installed Components

STEP	PROCEDURE	MECH	INSP
4.1	Remove left and right condenser brackets from the tail boom. (Ref photo 401, 402) By removing 10 each Rivets and 4 each Bolts per side (if installed)		
4.2	Remove right hand lower bracket from the tail boom. (Ref photo 403). Coax splitter.		
4.3	Remove 7-3/4 inch ring from the upper, right hand, and forward transmission deck. (Ref photo 404)		
4.4	Remove 3/4 inch tube from the upper right hand forward transmission deck. (Ref photo 404)		
4.5	Remove two each stiffeners from lower right hand forward transmission deck. (Ref photo 405)		
4.6	Remove four each caps from air distribution ducts located on the aft side of the cabin bulkhead. (Ref photo 406)		

RSG Products Inc.
REMOVAL OF FACTORY INSTALLED COMPONENTS – B4 Air Conditioning

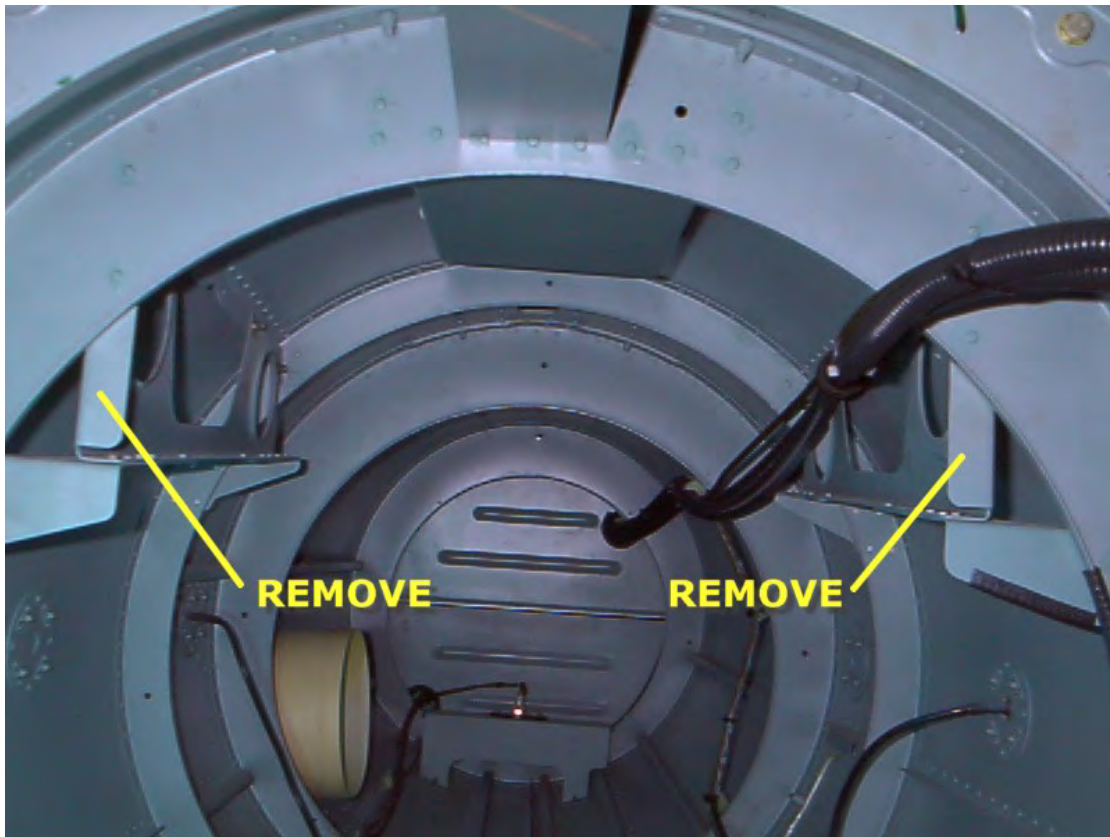

Photo 401

Removal of Condenser
Brackets



Photo 402

Condenser Brackets
Removed

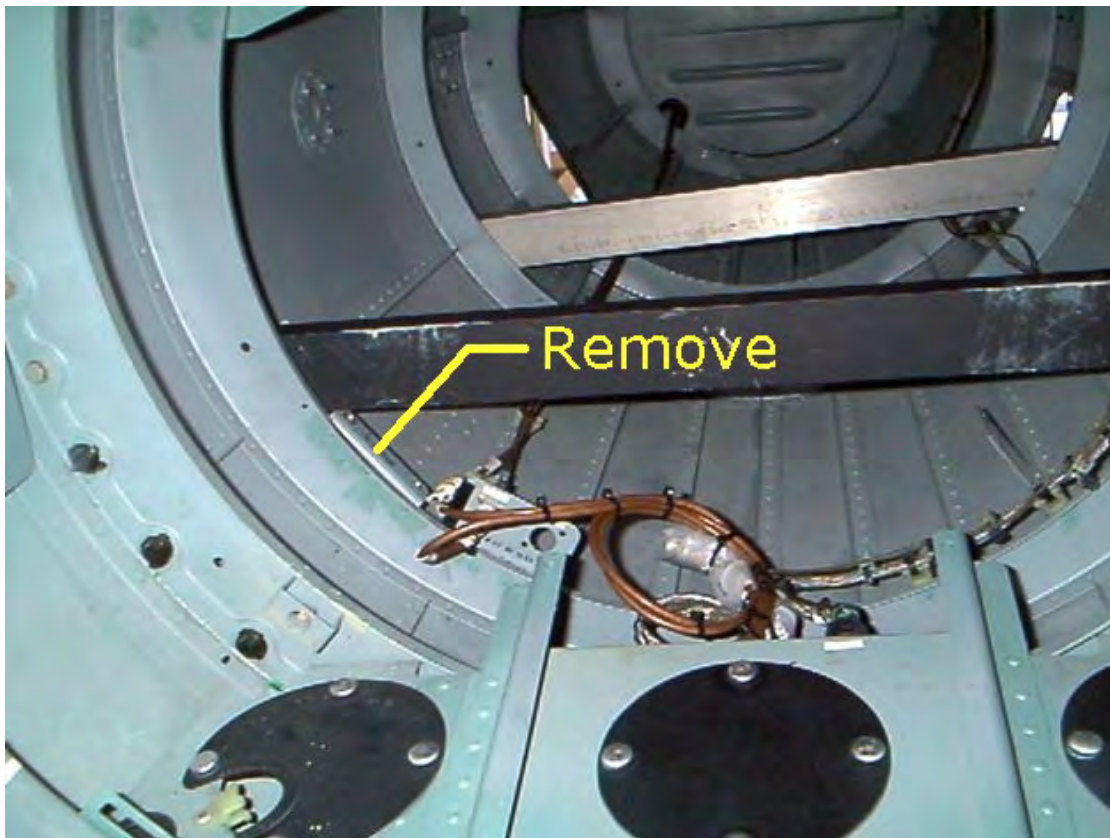

Photo 403

Removal of
Additional Bracket

RSG Products Inc.
REMOVAL OF FACTORY INSTALLED COMPONENTS – B4 Air Conditioning

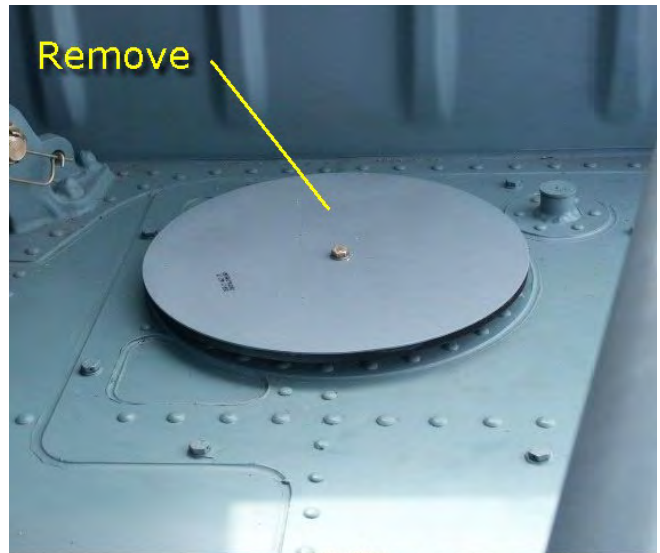

Photo 404
Removal of
Blocking Plate
and Ring



RSG Products Inc.
REMOVAL OF FACTORY INSTALLED COMPONENTS – B4 Air Conditioning



Photo 405

Remove 2 Existing
Stringers.

RSG Products Inc.
REMOVAL OF FACTORY INSTALLED COMPONENTS – B4 Air Conditioning

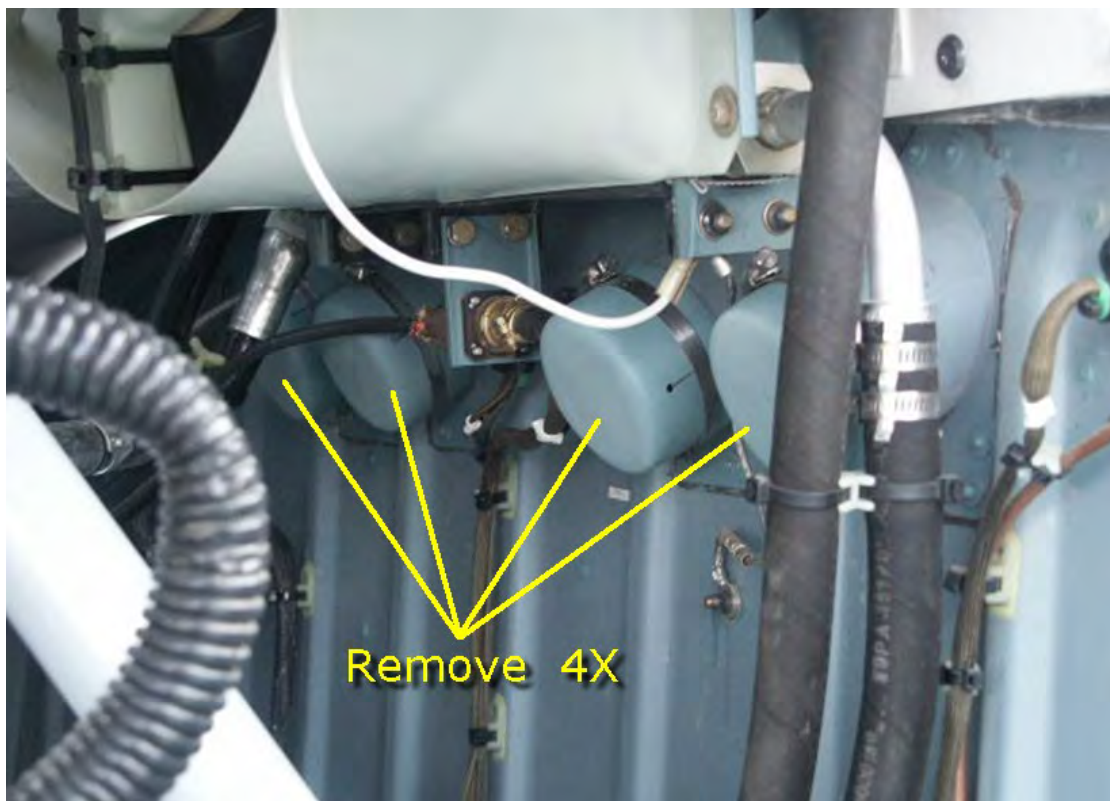

Photo 406

Remove Existing 4 Caps

Step 5

Installation of Aft Evaporator

Installation of Aft Evaporator

STEP	PROCEDURE	MECH	INSP
5.1	Position the right half doubler, fan, P/N 261370, on the upper transmission deck per the dimensions shown on drawing number 4-1-EC130. Mark and remove all existing rivets, bolts, and nut plates to allow the doubler to sit flat on deck. (Ref photo 501)		
5.2	Drill through deck using pilot holes in doubler. Back drill the doubler from existing holes in the deck. (Ref photo 502)		
5.3	Mark and cut openings in the transmission deck using doubler, P/N 261370, as a template. (Ref photo 503)		
5.4	Install doubler, P/N 261370, and right half fan doubler shim, P/N 261371 on right hand upper transmission deck in accordance with drawing number 4-1-EC130 using rivets.		
5.5	Position the aft evaporator return air duct, P/N 110015, in the right side baggage compartment as shown on drawing 4-2-EC130. Use the existing return air opening to locate the return air duct. Trim the return air duct as required to fit. (Ref photo 504)		
5.6	Remove the access panel from the outboard side of the aft evaporator, P/N 560016-O-1.		
5.7	Temporarily install the aft evaporator, P/N 560016-O-1 using 4 each. P/N AN3-5A, bolts, and P/N AN960-10, washers. (Ref photo 505)		
5.8	Locate and drill the holes for mounting the aft evaporator return air duct.		
5.9	Attach return air duct, P/N 110015 per print 4-1-EC130 sheet 2 of 2, aft return air screen doubler P/N 110008, and aft return air screen P/N 080010 per Print 5-3-EC130.		
5.10	SEAL THE EVAPORATOR TO THE RETURN AIR DUCT WITH ALUMINUM FOIL TAPE by reaching through the outboard opening in the evaporator. Install the aft evaporator access panel.		

RSG Products Inc.
 INSTALLATION OF AFT EVAPORATOR – B4 Air Conditioning

STEP	PROCEDURE	MECH	INSP
5.11	Install the aft evaporator blower fan assembly, P/N IFSS 050143-2 DCB, using five each, P/N AN3-5A, bolts, and P/N AN960-10 washers per print 4-1-EC130.		
5.12	Position the air distribution manifold assembly, P/N 520003-130, on the aft cabin wall to the dimensions shown on drawing 4-1-EC130. Align outlets on the air distribution manifold with the existing openings in the aft cabin wall. Mark and drill 4 holes. (Ref photo 506) NOTE: MAY NEED TO REMOVE/REINSTALL OIL COOLER BLOWER TO FACILITATE INSTALL.		
5.13	Install the aft evaporator air distribution duct on the aft cabin wall using four each, P/N AN525-10R6, screws and four each P/N AN960-10 washers.		

RSG Products Inc.
INSTALLATION OF AFT EVAPORATOR – B4 Air Conditioning

STEP	PROCEDURE	MECH	INSP
5.14	Cut and attach 4 pieces of 2-1/2 inch flex duct P/N 060025 to the existing openings in the aft cabin wall to the existing openings in the air distribution duct. Cut and attach 4 pieces (approx 13" long each) of 2-1/2 inch flex duct P/N 060025, connect one end to the existing opening in the cabin headliner and the other to the existing air distribution system in the headliner (* may have to cut wire back in 2 ½" tube to obtain sealed clamp up). Secure each end with 3" band clamps. Insulate the duct in the deck area with foam tape, P/N 070078, and wrap with aluminum tape, P/N 070076. (Ref photo 506 & 507)		
5.15	Install 5-inch flex duct P/N 060004, from the aft evaporator fan assembly to the aft evaporator air distribution duct and secure each end with two each 6" band clamps P/N 060035. Insulate the duct with foam tape and wrap with aluminum tape. (Ref photo 508)		
5.16	Remove the cover plate AEC, P/N 350A580483.20A or fresh air duct, from the fresh air opening located on the upper center of the Doghouse cowling. (Ref photo 509) Use cover plate to locate mounting holes.		
5.17	Install the fresh air intake assembly, P/N 540007, using the existing hardware with fresh air screen P/N 080008. (Ref photo 510) Per drawing 4-1-EC130 sheet 2 of 2.		
5.18	Install 3-inch flex duct P/N 060024, from the fresh air inlet valve assembly to the 3-inch opening in the aft evaporator air distribution duct. Secure each end of the duct with two each 3 inch band clamps.		



Photo 501

Removal of all rivets for
Doubler installation.

RSG Products Inc.
INSTALLATION OF AFT EVAPORATOR – B4 Air Conditioning



Photo 502

Back Drill for Doubler
Installation.

RSG Products Inc.
INSTALLATION OF AFT EVAPORATOR – B4 Air Conditioning

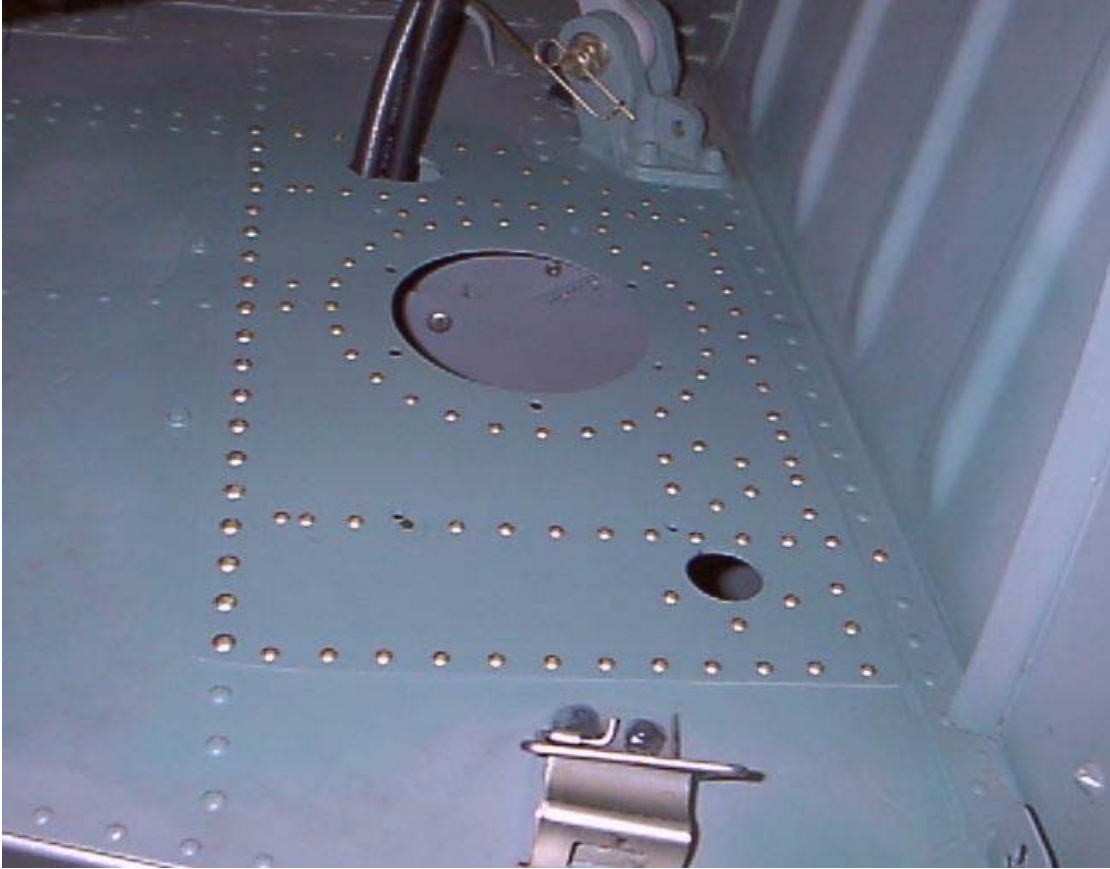

Photo 503

Doubler Installed
P/N 261370

RSG Products Inc.
INSTALLATION OF AFT EVAPORATOR – B4 Air Conditioning



Photo 504

Return Air Duct

RSG Products Inc.
INSTALLATION OF AFT EVAPORATOR – B4 Air Conditioning



Photo 505
5" Blower installation
Aft Evaporator

RSG Products Inc.
INSTALLATION OF AFT EVAPORATOR – B4 Air Conditioning



Photo 506

Air Distribution
Manifold

RSG Products Inc.
INSTALLATION OF AFT EVAPORATOR – B4 Air Conditioning



Photo 507

Air Distribution Manifold
With Connections
Attached.

RSG Products Inc.
INSTALLATION OF AFT EVAPORATOR – B4 Air Conditioning



Photo 508

Air Ducts Insulated
and Wrapped.

RSG Products Inc.
INSTALLATION OF AFT EVAPORATOR – B4 Air Conditioning

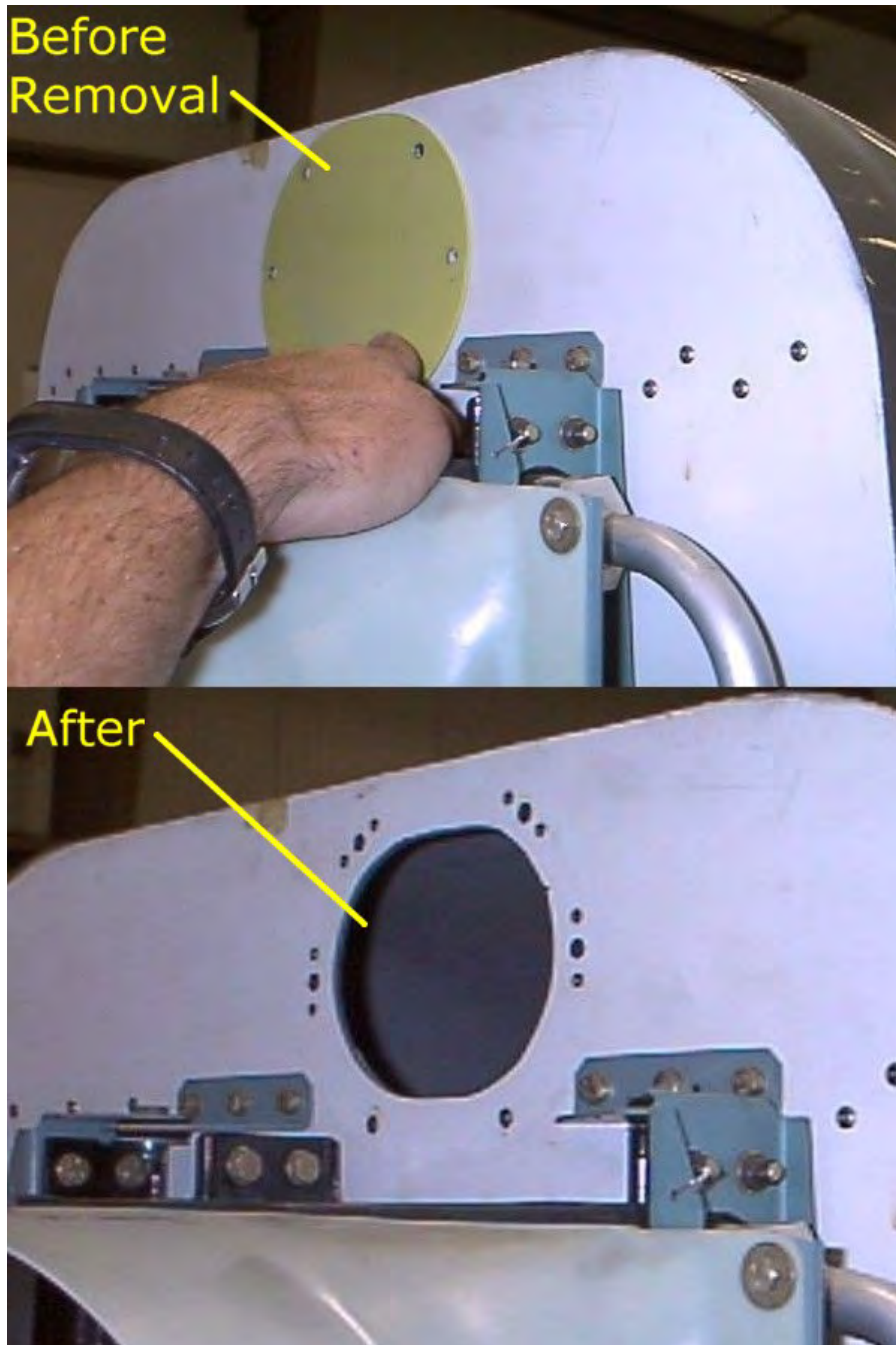

Photo 509

Removal of Fresh Air Plate

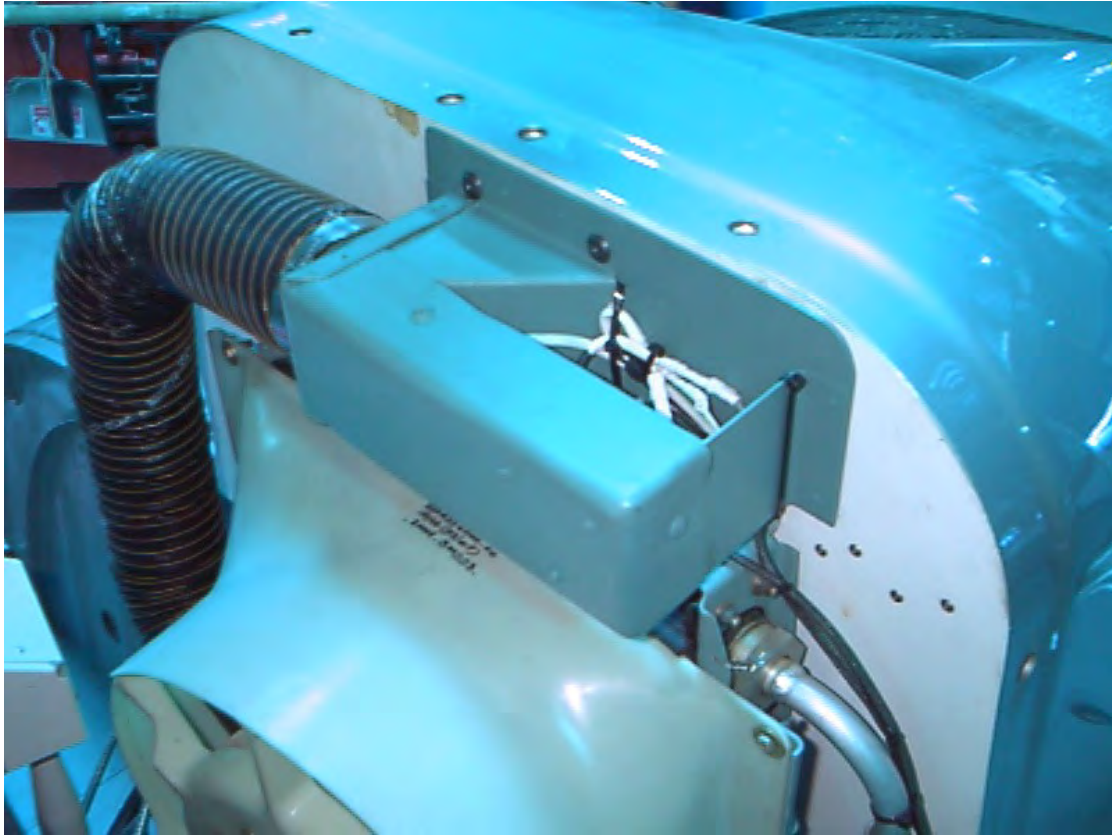
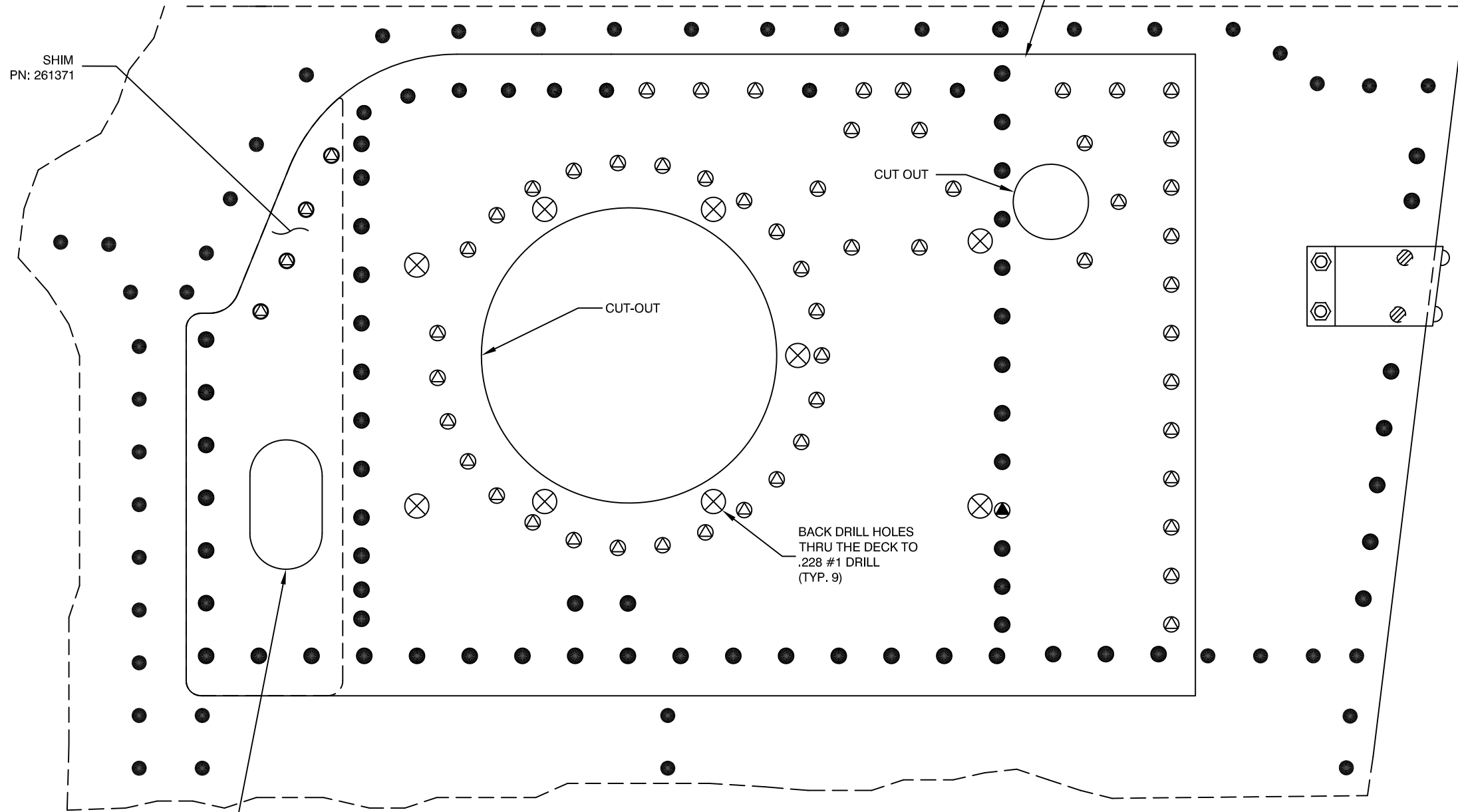

Photo 510

Installation of Fresh Air
Valve and 3" Duct

NOTE:
 RIVET LENGTH MAYBE DETERMINED UPON INSTALLATION.
 INTERCHANGEABILITY BETWEEN MS20470AD-4-X RIVETS
 AND CR3242-4-X RIVETS IS APPROVED.

- MS20470AD-4-X (FIELD)
- ⊙ MS20470AD-4-X (REPLACES EXIST. RIVETS)
- ⊙ MS20426AD-4-X (CSK. AT TOP SURFACES)
- ⊗ .228 DIA HOLE #1 DRILL (FOR AN 3-5A BOLT)
- EXISTING



VIEW LOOKING DOWN AT TRANSMISSION DECK

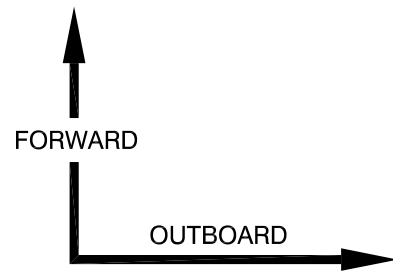

REVISION RECORD				
REV	DATE	DESCRIPTION OF CHANGE	APPVD. BY	REV. BY
A	10/15/03	CORRECTED COUBLER TO MATCH MFG DRAWING. ADDED NOTE FOR CUTOUT.		JTYE
B	03/31/09	REVISED TITLE BLOCK. ADDED SHIM PN: 261371 TO SHEET 1. CORRECTED VERTICAL DIMENSION ON SHEET 2. CORRECTED RIVET LEGEND ON SHEET 1. REMOVED ADAPTERS AND CORRECTED HOSE AND BAND CLAMP CALLAOUTS ON SHEET 2. ADDED TAG FOR VIEW A-A. ADDED ALT PN'S: FSS 050143, -1, -2, -3 DCB, TO SHEET 2 OF 2. ADDED RESISTOR MOUNT ASSEMBLYPN: 520463. RECONFIGURED HARDWARE ACCORDINGLY.		JTYE
C	09/01/14	CHANGED TITLE BLOCK AND REVISION BLOCK. INCORPORATED ECO # 0484.		AJC
D	08/04/23	INCORPORATED ECO 1028.		SGB



PROPRIETARY NOTICE		NEXT ASSY.		TOLERANCES EXCEPT AS SHOWN			
TO ALL PERSONS RECEIVING THIS DOCUMENT THIS DOCUMENT AND INFORMATION OR TECHNICAL DATA AND DESIGNS CONTAINED HEREIN ARE PROPRIETARY DATA AND EXCLUSIVE PROPERTY OF RSG PRODUCTS INC. AND IS DELIVERED ON THE EXPRESS CONDITION THAT NEITHER THIS DOCUMENT NOR THE INFORMATION CONTAINED HEREIN SHALL BE DISCLOSED TO OTHERS, REPRODUCED IN WHOLE OR IN PART, OR USED FOR THE MANUFACTURE OR FABRICATION OF PARTS FOR ANYONE OTHER THAN RSG PRODUCTS INC. WITHOUT WRITTEN CONSENT AND AUTHORIZATION, AND THAT NO RIGHT IS GRANTED TO DISCLOSE OR SO USE ANY INFORMATION CONTAINED IN SAD DOCUMENT. THIS RESTRICTION DOES NOT LIMIT THE RIGHT TO USE INFORMATION OBTAINED FROM ANOTHER SOURCE.		APPROVED BY:		.X: ±.1 .XX: ±.03 .XXX: ±.010 X.X°: ±.5° BREAK ALL SHARP EDGES .01 ALL DIMENSIONS IN INCHES UNLESS OTHERWISE STATED			
				DATE:		DRAWN BY: JTYE DATE: 06/15/03 REV.: D SCALE: N/A SHEET: 1 OF 3	
						APPLICATION: EC 130 B4 DWG. NO.: 4-1-EC130	

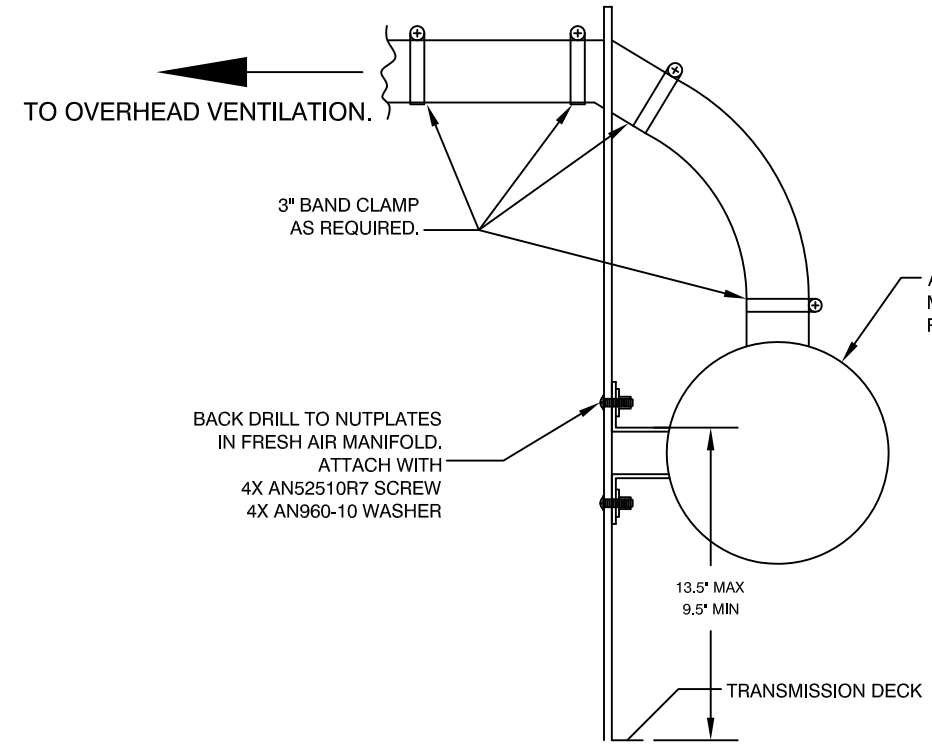

VIEW A-A



RECIEVER/DRIER INSTALLED



ROUTE DRAIN TUBE FROM EVAP. DOWN THRU EXISTING HOLE.

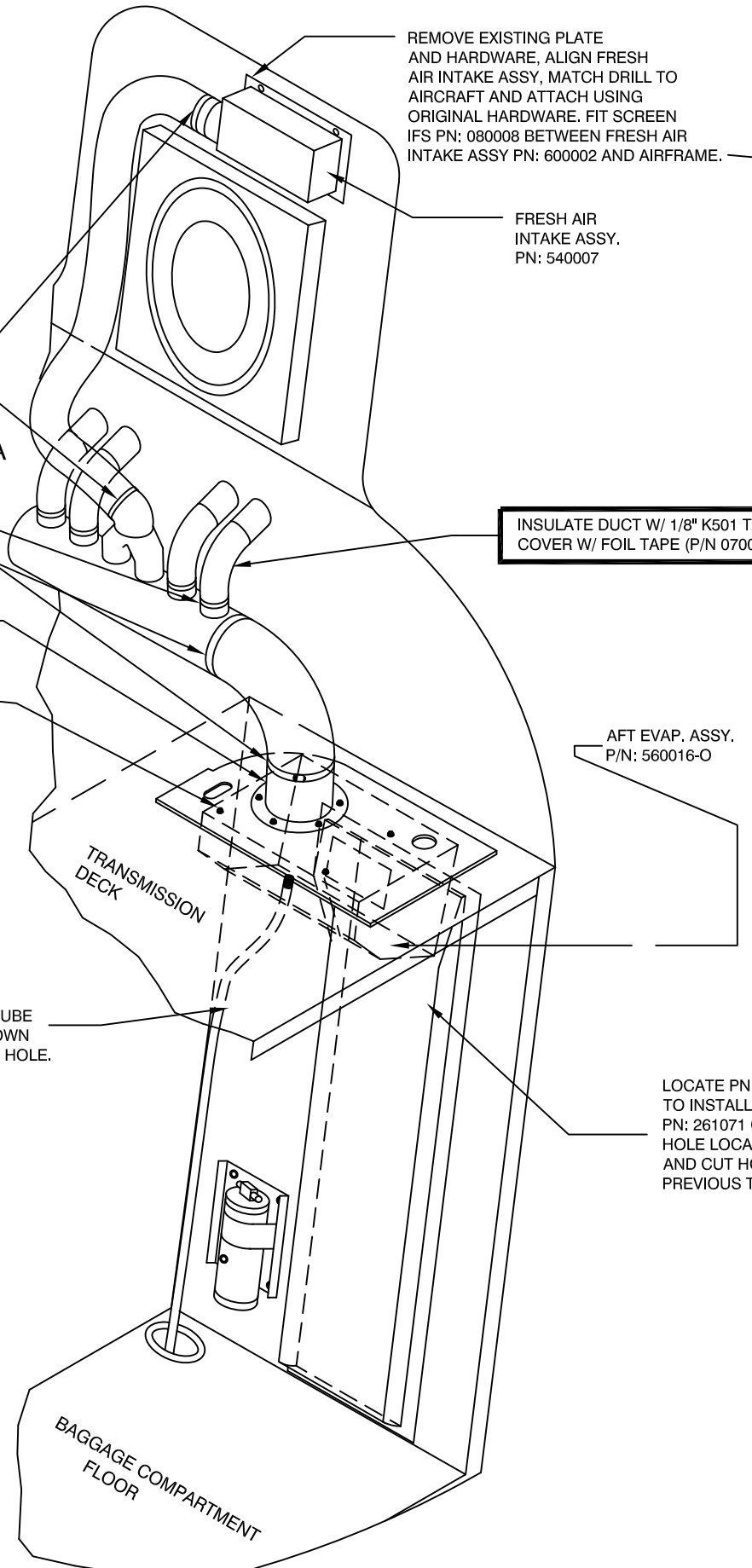

REMOVE EXISTING PLATE AND HARDWARE, ALIGN FRESH AIR INTAKE ASSY, MATCH DRILL TO AIRCRAFT AND ATTACH USING ORIGINAL HARDWARE. FIT SCREEN IFS PN: 080008 BETWEEN FRESH AIR INTAKE ASSY PN: 600002 AND AIRFRAME.

FRESH AIR INTAKE ASSY. PN: 540007

INSULATE DUCT W/ 1/8" K501 TAPE COVER W/ FOIL TAPE (P/N 070078)

AFT EVAP. ASSY. P/N: 560016-O

LOCATE PN: 110015 RETURN AIR DUCT TO INSTALL POSITION, REMOVE PN: 261071 CLOSEOUT PANEL, MARK HOLE LOCATION AND SIZE, REMOVE AND CUT HOLE FOR MATCHED FIT PREVIOUS TO INSTALL.

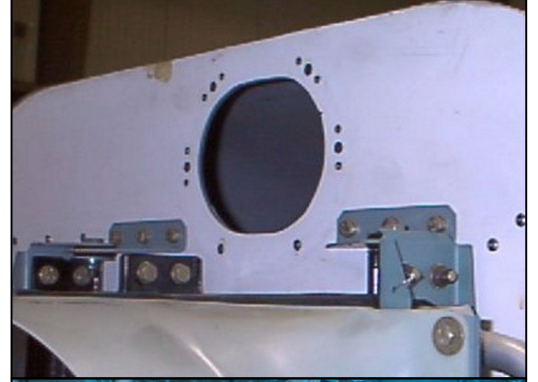
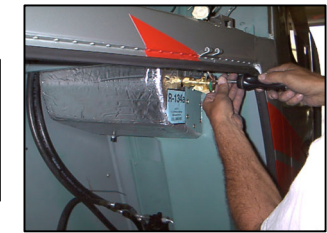

RSG PRODUCTS INC.
A ROTORCRAFT SERVICES GROUP COMPANY

TITLE: AFT EVAPORATOR INSTALL				
DRAWN BY: JTYE	DATE: 06/15/03	REV.: D	SCALE: N/A	SHEET: 2 OF 3
APPLICATION: EC 130 B4			DWG. NO.: 4-1-EC130	

8 7 6 5 4 3 2 1

D C B A

OPTIONAL INSTALL FOR NOISE REDUCTION
WHEN BRUSHLESS MOTORS ARE INSTALLED;
P/Ns: IFSS 050143 DCB, -1 DCB, -2 DCB, AND -3
DCB. INSTALL THE FOLLOWING, MAINTAINING
BURNISHING REQ:

04-350-21-108-01 (AFT EVAP EMI FILTER
BRACKET) 1EA

13619-RF16883 (EMI FILTER) 1EA
MS21075-3N (NUTPLATE) 2EA
CCR264CS-3-02 (RIVET) 4EA
MS27039-0807 (SCREW) 2EA
NAS620-8L (WASHER) 2EA

FOR BRACKET ATTACHMENT
USE EXISTING AN3-5A BOLTS, 3
PLACES

TRANSMISSION
DECK

BURNISHING REQUIREMENTS:
REMOVE PROTECTIVE FINISH LOCALLY
FROM SURFACES WHERE EQUIPMENT
MOUNTING HOLES ARE LOCATED, TO
ASSURE A PROPER ELECTRICAL BOND
MEASURING A MAXIMUM OF 2.5
MILLIOHMS.



TITLE:
AFT EVAPORATOR INSTALL

DRAWN BY: JTYE DATE: 06/15/03 REV.: D SCALE: N/A SHEET: 3 OF 3

APPLICATION: EC 130 B4 DWG. NO.: 4-1-EC130

8 7 6 5 4 3 2 1

D C B A

REVISION RECORD				
REV	DATE	DESCRIPTION OF CHANGE	APPVD. BY	REV. BY
A	10/17/03	REVISED TITLE BLOCK. CHANGED NO. OF BOLTS TO 4 ON INBOARD AND 5 ON OUTBOARD SIDE OF AIR DUCT. ADJUSTED INSTRUCTIONS ACCORDINGLY. CORRECTED PN: 560016-O, IS NOW PN: 560016-O-1 DUE TO PN CONFLICT.		JTYE
B	9/1/14	CHANGED TITLE BLOCK AND REVISION BLOCK.		AJC

INSTALLATION INSTRUCTIONS:

1. AFT EVAPORATOR AND RETURN AIR DUCT INSTALLATION:
2. TRIAL FIT EVAPORATOR ASSEMBLY, P/N 560016-O-1 UNDER NEWLY INSTALLED COUBLER WITH 4X AN3-5A BOLTS AND 4X AN960-10 WASHERS AS SHOWN.
3. LOCATE A LINE ONE (1) INCH ABOVE THE LOWER/FORWARD FACE OF THE EVAPORATOR.
4. TRIAL FIT RETURN AIR DUCT P/N 110015. LOCATE AND DRILL AT FOUR PLACES ON INBOARD SIDE, EQUALLY SPACED, AT INBOARD EDGE OF RETURN AIR DUCT FLANGE. DRILL 5 PLACES, EQUALLY SPACED, ON OUTBOARD EDGE OF RETURN SECTION.
5. INSTALL DRAIN LINE AND ROUTE AS SHOWN. SECURE DRAIN LINE WITH ADEL CLAMPS OR TIE WRAPS AND ROUTE TO A LOCATION OUTBOARD OF THE BELLY PANEL.

NOTE:

ENSURE THAT DRAIN LINE IS NOT CRIMPED WHEN BELLY PANEL IS RE-INSTALLED.

CAUTION:

BE SURE THAT THE DRAIN LINE IS PROPERLY SECURED AND LONG ENOUGH SO THAT CONDENSATION DOES NOT FLOW FROM THE LINE, AFT INTO THE BAGGAGE COMPARTMENT.

NOTE: ENSURE THAT DRILLING DOES NOT HIT COIL

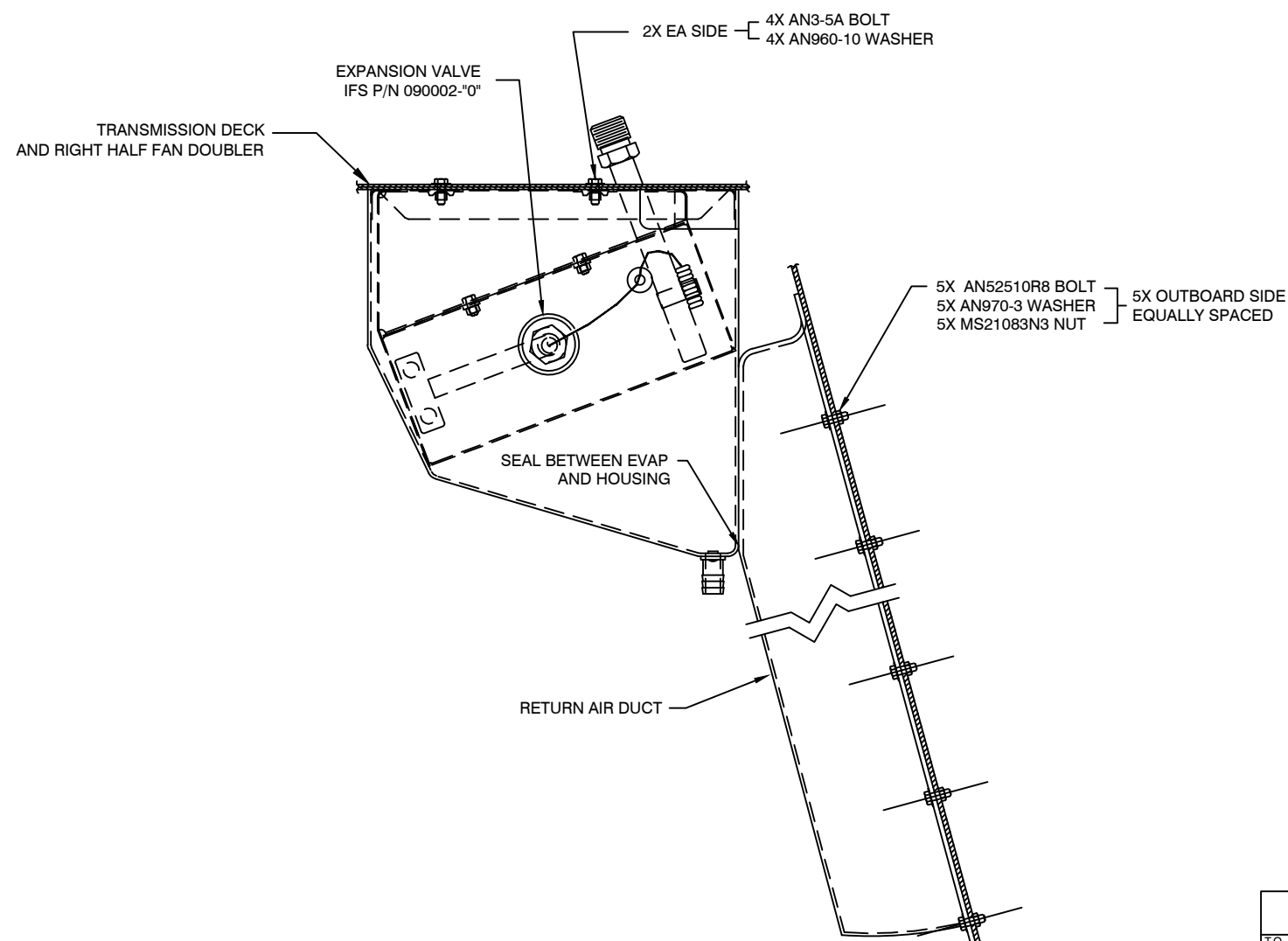

**VIEW OUTBOARD
LOOKING INBOARD**

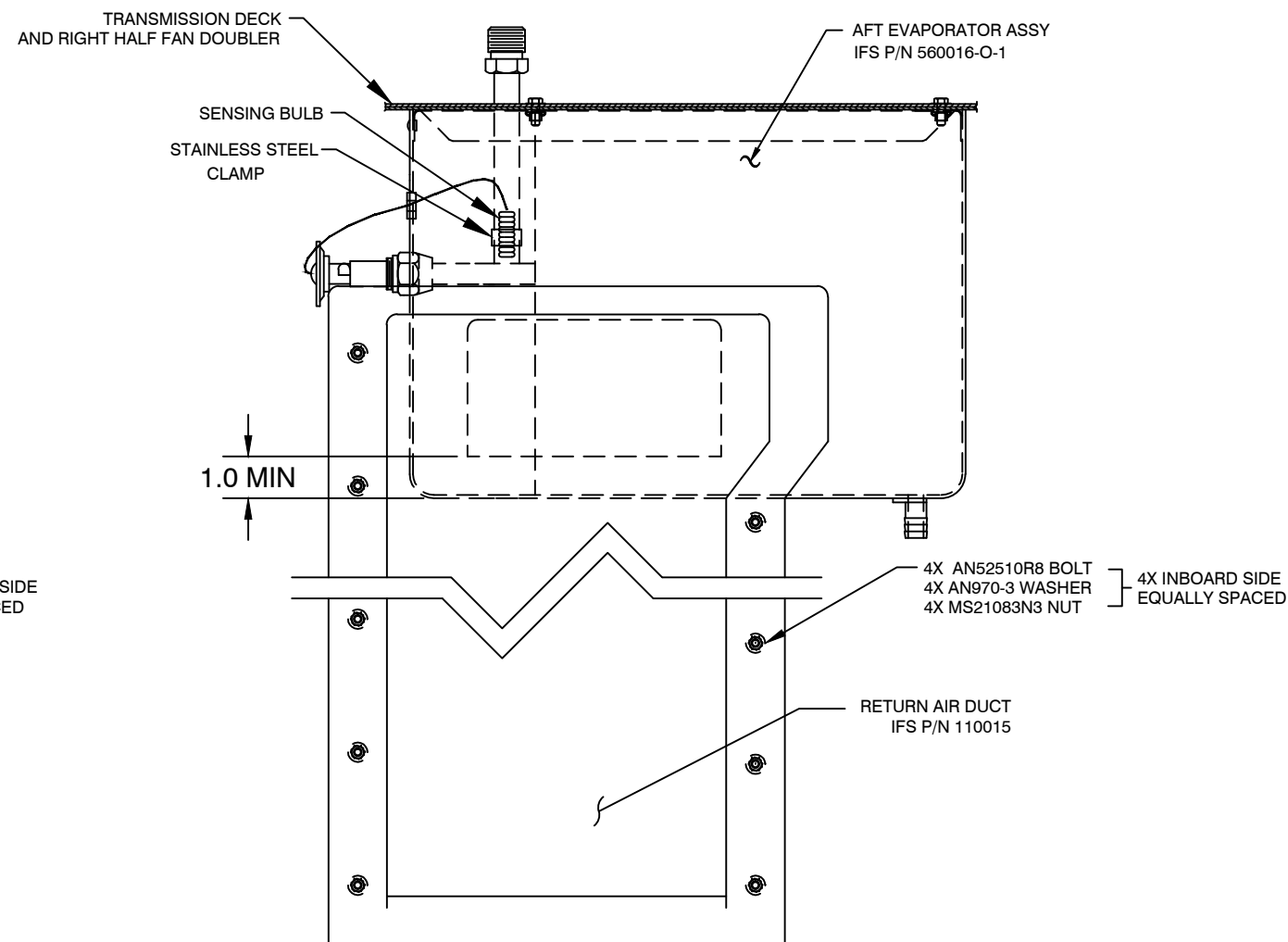

**VIEW LOOKING AFT
FOR USE WITH AFT EVAPORATOR
ASSEMBLY IFS P/N 560016-O**

PROPRIETARY NOTICE TO ALL PERSONS RECEIVING THIS DOCUMENT THIS DOCUMENT AND INFORMATION OR TECHNICAL DATA AND DESIGNS CONTAINED HEREIN ARE PROPRIETARY DATA AND EXCLUSIVE PROPERTY OF RSG PRODUCTS INC. AND IS DELIVERED ON THE EXPRESS CONDITION THAT NEITHER THIS DOCUMENT NOR THE INFORMATION CONTAINED HEREIN SHALL BE DISCLOSED TO OTHERS, REPRODUCED IN WHOLE OR IN PART, OR USED FOR THE MANUFACTURE OR FABRICATION OF PARTS FOR ANYONE OTHER THAN RSG PRODUCTS INC. WITHOUT WRITTEN CONSENT AND AUTHORIZATION, AND THAT NO RIGHT IS GRANTED TO DISCLOSE OR SO USE ANY INFORMATION CONTAINED IN SAD DOCUMENT. THIS RESTRICTION DOES NOT LIMIT THE RIGHT TO USE INFORMATION OBTAINED FROM ANOTHER SOURCE.	NEXT ASSY.	TOLERANCES EXCEPT AS SHOWN		
		.X: ±.1 .XX: ±.03 .XXX: ±.010 X.X°: ±.5° BREAK ALL SHARP EDGES .01 ALL DIMENSIONS IN INCHES UNLESS OTHERWISE STATED		TITLE: AFT EVAPORATOR INSTALL
	APPROVED BY:	DATE:		DRAWN BY: JTYE DATE: 06/15/03 REV.: B SCALE: N/A SHEET: 1 OF 1
				APPLICATION: EC 130 B4 DWG. NO.: 4-2-EC130

REVISION RECORD				
REV	DATE	DESCRIPTION OF CHANGE	APPVD. BY	REV. BY
A	10/17/03	CHANGED HARDWARE CALLOUT DUE TO LENGTH ISSUES WITH EXISTING HARDWARE. CHANGED SCREEN CORNERS TO MATCH MFG DRAWING.	LA	JTYE
B	05/28/09	REVISED TITLE BLOCK.	MLD	JTYE
C	9/1/14	CHANGED TITLE BLOCK AND REVISION BLOCK.		AJC

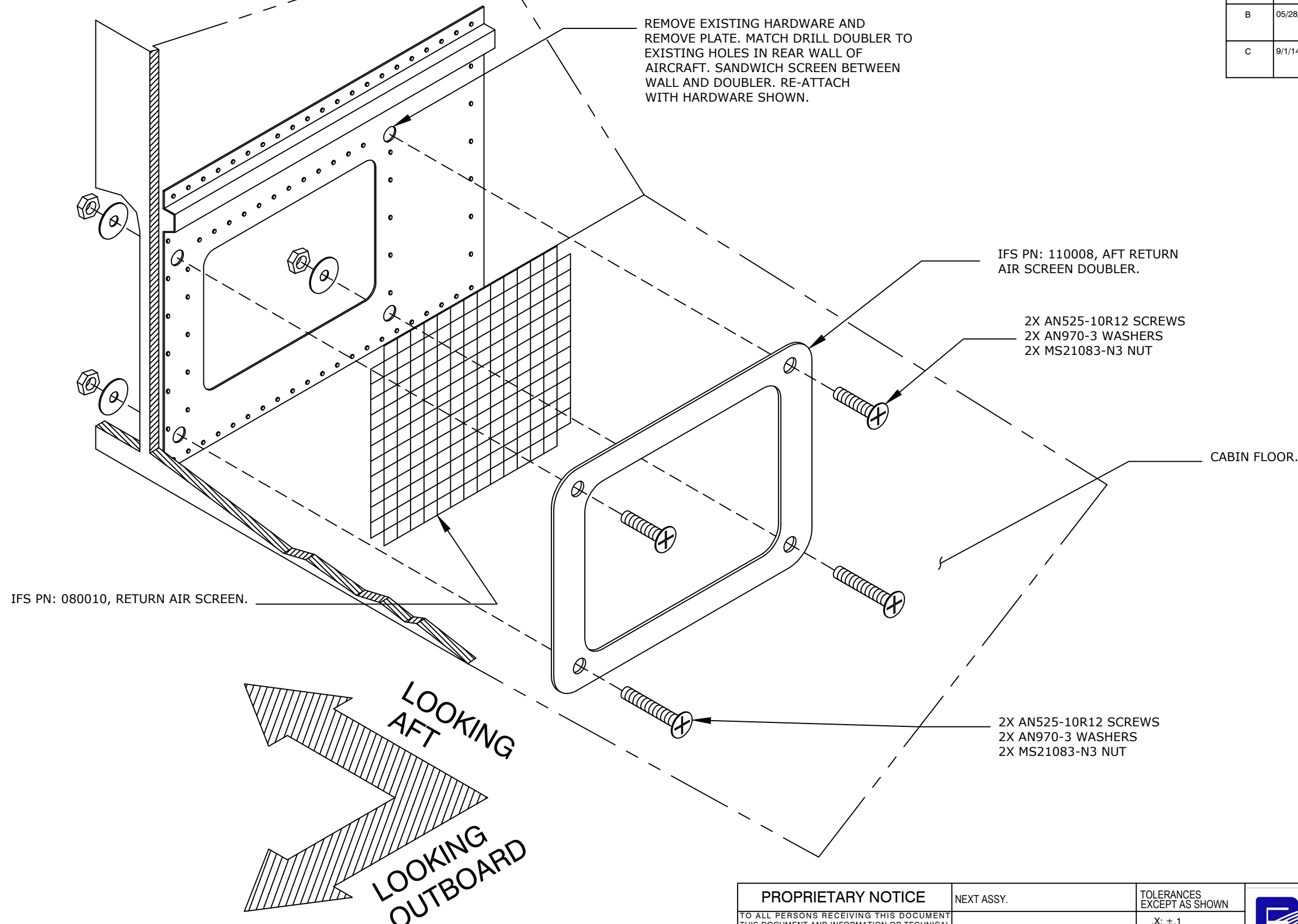

REMOVE EXISTING HARDWARE AND REMOVE PLATE. MATCH DRILL DOUBLER TO EXISTING HOLES IN REAR WALL OF AIRCRAFT. SANDWICH SCREEN BETWEEN WALL AND DOUBLER. RE-ATTACH WITH HARDWARE SHOWN.

IFS PN: 110008, AFT RETURN AIR SCREEN DOUBLER.

2X AN525-10R12 SCREWS
2X AN970-3 WASHERS
2X MS21083-N3 NUT

CABIN FLOOR.

IFS PN: 080010, RETURN AIR SCREEN.

2X AN525-10R12 SCREWS
2X AN970-3 WASHERS
2X MS21083-N3 NUT

LOOKING AFT
LOOKING OUTBOARD

PROPRIETARY NOTICE TO ALL PERSONS RECEIVING THIS DOCUMENT THIS DOCUMENT AND INFORMATION OR TECHNICAL DATA AND DESIGNS CONTAINED HEREIN ARE PROPRIETARY DATA AND EXCLUSIVE PROPERTY OF RSG PRODUCTS INC. AND IS DELIVERED ON THE EXPRESS CONDITION THAT NEITHER THIS DOCUMENT NOR THE INFORMATION CONTAINED HEREIN SHALL BE DISCLOSED TO OTHERS, REPRODUCED IN WHOLE OR IN PART, OR USED FOR THE MANUFACTURE OR FABRICATION OF PARTS FOR ANYONE OTHER THAN RSG PRODUCTS INC. WITHOUT WRITTEN CONSENT AND AUTHORIZATION, AND THAT NO RIGHT IS GRANTED TO DISCLOSE OR SO USE ANY INFORMATION CONTAINED IN SAD DOCUMENT. THIS RESTRICTION DOES NOT LIMIT THE RIGHT TO USE INFORMATION OBTAINED FROM ANOTHER SOURCE.	NEXT ASSY.	TOLERANCES EXCEPT AS SHOWN		
		.X: ±.1 .XX: ±.03 .XXX: ±.010 X.X°: ±.5° BREAK ALL SHARP EDGES .01 ALL DIMENSIONS IN INCHES UNLESS OTHERWISE STATED		TITLE: AIR DISTRIBUTION
	APPROVED BY:		DATE:	DRAWN BY: JTYE DATE: 06/15/03 REV.: C SCALE: N/A SHEET: 1 OF 1
				APPLICATION: EC 130 B4 DWG. NO.: 5-3-EC130

Step 6

Installation of Condenser

RSG Products Inc.
 INSTALLATION OF CONDENSER – B4 Air Conditioning

Installation of Condenser

STEP	PROCEDURE	MECH	INSP
6.0	NOTE: TO INSTALL BRACKETS PARALLEL.		
6.1	Locate the forward brace, condenser, P/N 261360 per Drawing 7-1-EC130. Align reference hole in support angle tooling hole tail boom rib. Level support to aircraft. Mark and drill 4 each, ¼-inch mount holes in support. Transfer drill holes to tail boom rib. (Ref Print 7-1-EC130 and 7-2-EC130).		
6.2	Temporarily remove 7-inch blower assembly from Condenser Assy. P/N 550003-O. Position condenser in tail boom.		
6.3	Locate AFT brace, condenser, P/N 261361. Per Drawing 7-1-EC130. Ensure gap exists between support and tail boom skin.		
6.4	Position forward condenser brace and condenser. Use condenser to position AFT brace. Mark and drill 4 each ¼-inch mount holes in aft support and transfer to tail boom rib. NOTE: May need to relocate tie off points for supports to be low enough.		
6.5	Position condenser approximately 2.5-inches from right side of tail boom rib at forward support, and square to forward support. Mark and drill 4 each, ¼-inch mount holes in condenser and support braces. (Ref Photo 602)		
6.6	Mount AFT condenser brace using 4 each, P/N AN4-5A, bolts, 8 each, P/N AN960-416, or P/N AN960-416L, washers, and 4 each, P/N MS21044-N4, nuts.		
6.7	Position condenser and forward brace in tail boom. Mount forward support using 4 each, P/N AN4-5A, bolts, 8 each, P/N AN960-416 or AN960-416L, washers.		
6.8	Mount condenser to support braces using 4 each, P/N AN4-6A, bolts, 8 each, P/N AN960-416 or AN960-416L, washers, and 4 each, P/N MS21044-N4, nuts.		
6.9	Reinstall 7-inch blower assembly, PN IFSS 050084-7-3.		

RSG Products Inc.
INSTALLATION OF CONDENSER – B4 Air Conditioning

Installation of Condenser

STEP	PROCEDURE	MECH	INSP
6.10	Fit condenser exhaust assembly, P/N 520001 to right side of tail boom opening drill to match nut plates.		
6.11	Fit condenser exhaust tube, P/N 250444, trim as necessary		
6.12	Install the exhaust tube through the round opening in the tail boom. Slide the exit duct over the 7-inch blower assembly and clamp with 1 each 7-inch band clamp P/N 060038 (Ref Photo 604/Print 7-2-EC130). NOTE: Duct does not interfere with wires for blower.		
6.13	Install condenser exhaust assembly, P/N 520001 over round hole in the right side of tail boom Per drawing 7-2-EC130, (verify that existing hardware is not too short).		
6.14	Modification of tail boom air inlet screen, P/N 080040, and camlocks P/N 2600-9. Per Print 7-3-EC130.		

RSG Products Inc.
INSTALLATION OF CONDENSER– B4 Air Conditioning

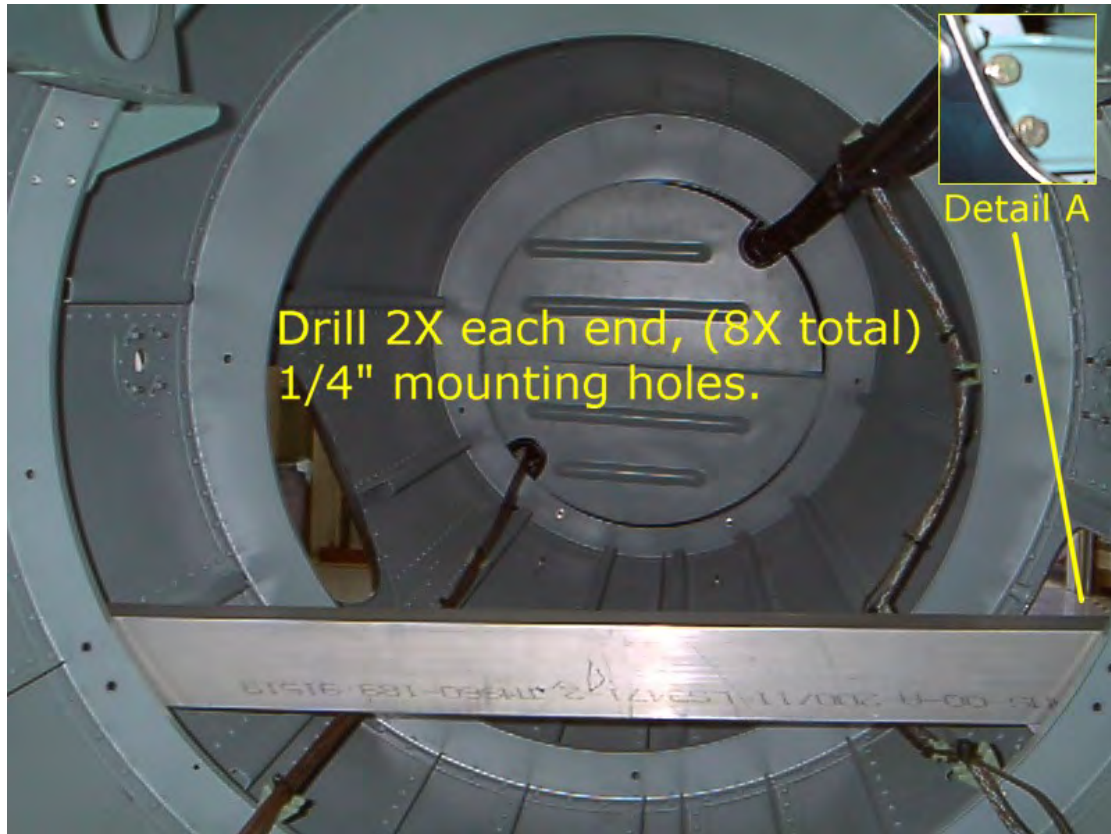

Photo 601

Locate, Drill and
Attach Condenser Support
Angles.

RSG Products Inc.
INSTALLATION OF CONDENSER– B4 Air Conditioning

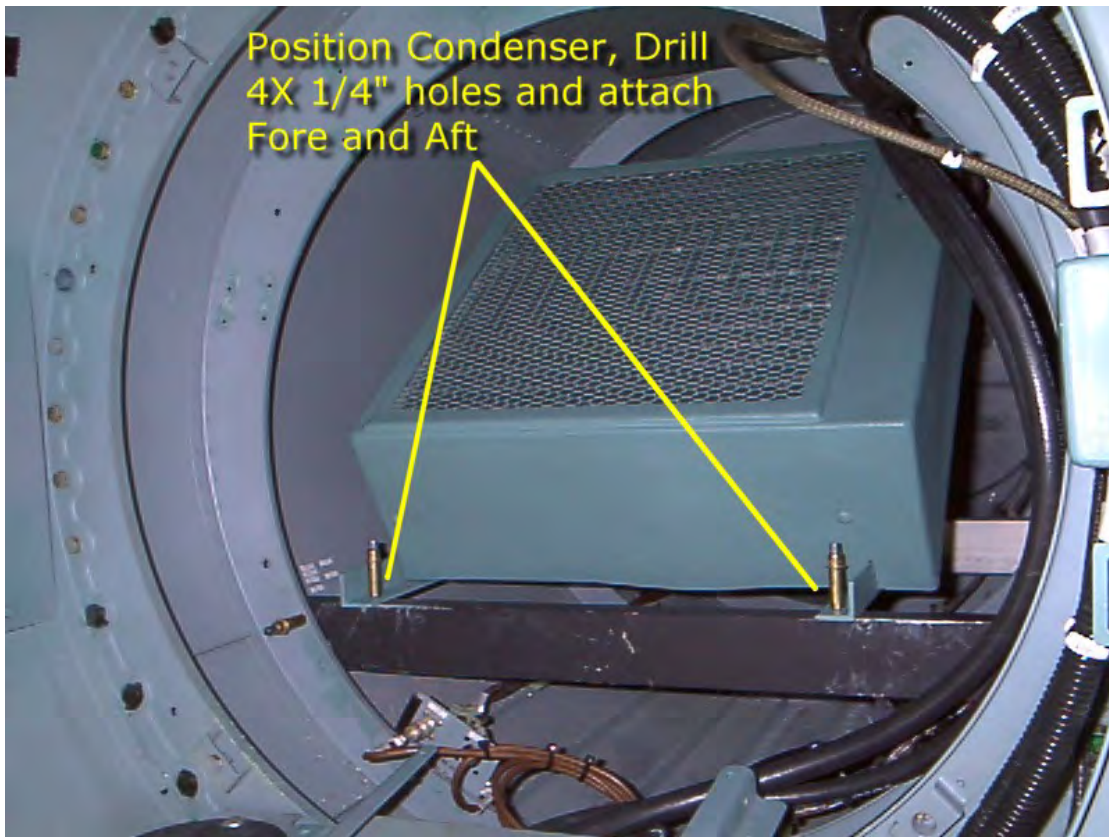

Photo 602

Condenser positioned
on Mounting Angles.
Not bolted.

RSG Products Inc.
INSTALLATION OF CONDENSER– B4 Air Conditioning

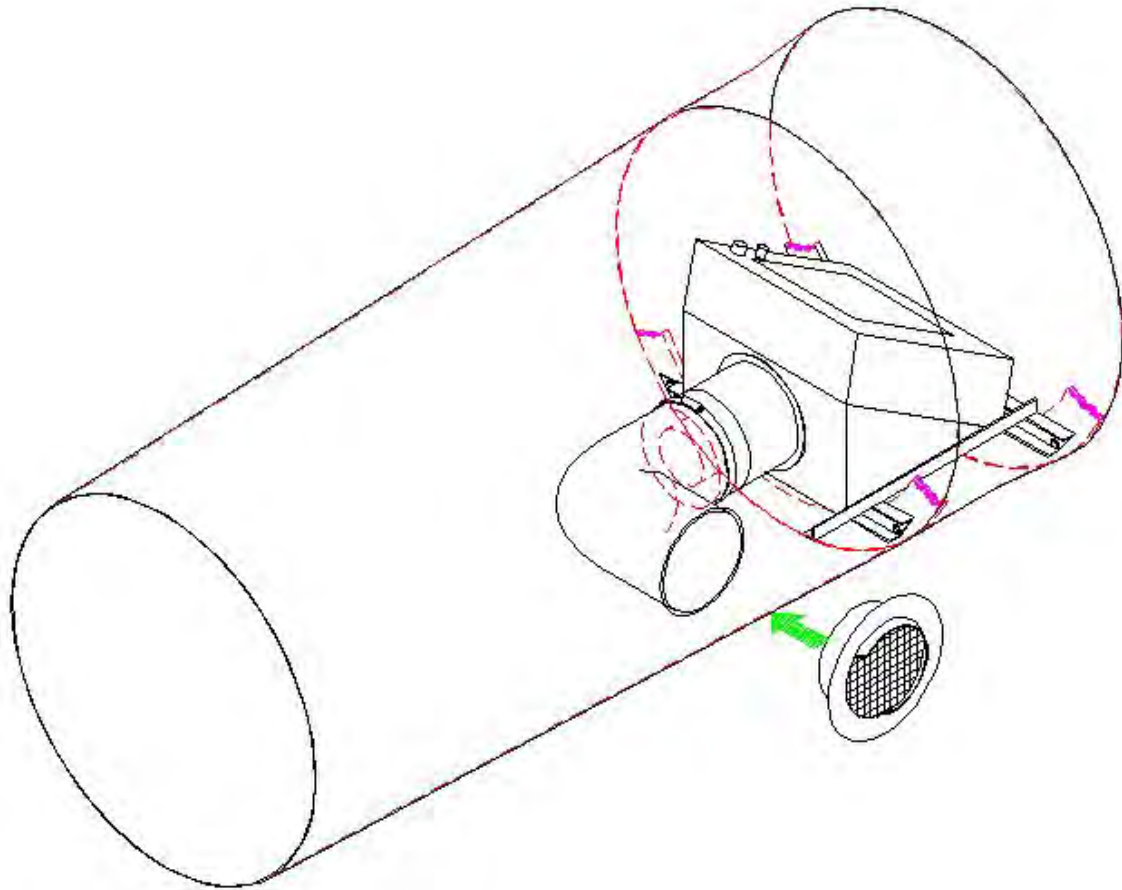

Photo 603

Condenser Exhaust Tube

RSG Products Inc.
INSTALLATION OF CONDENSER– B4 Air Conditioning



Photo 604

Condenser Air Outlet

REVISION RECORD				
REV	DATE	DESCRIPTION OF CHANGE	APPVD. BY	REV. BY
A	10/20/03	REVISED TITLE BLOCK. ADDED PN's FOR CLARITY, CHANGED ALL MOUNTING BOLTS TO SAME SIZE. ADDED GROUNDING STUD FOR MOTOR. ADDED 4.75" DIM. FOR CLARITY, CHANGED TITLE BLOCK PER ECO 0103. CORRECTED QTY OF AN3-4A BOLT AND MS21044N3 NUT.	LA	JTYE
B	9/1/14	CHANGED TITLE BLOCK AND REVISION BLOCK.		AJC

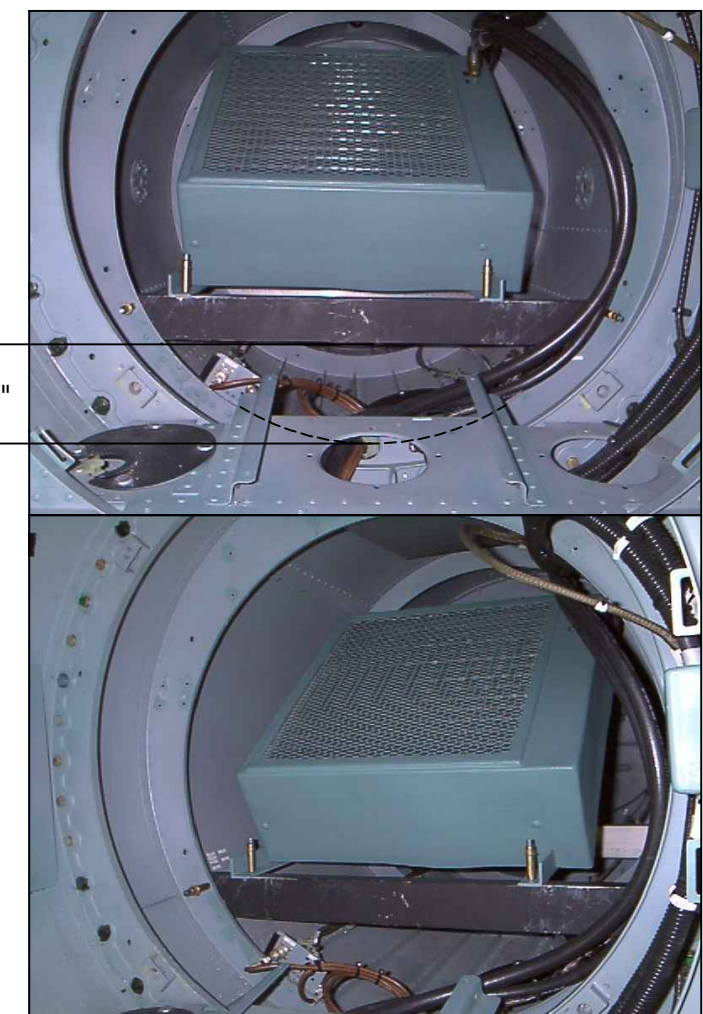
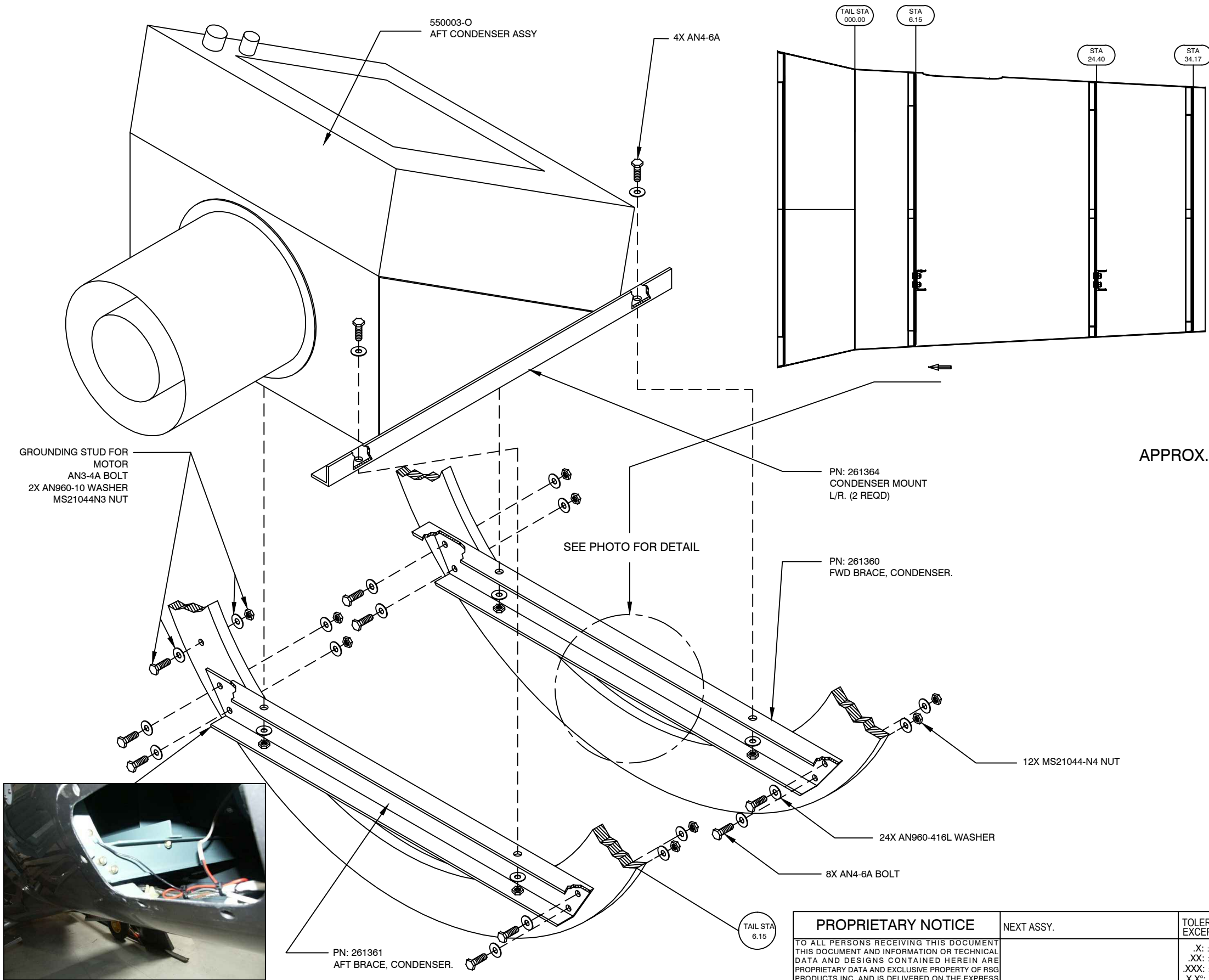

PROPRIETARY NOTICE TO ALL PERSONS RECEIVING THIS DOCUMENT THIS DOCUMENT AND INFORMATION OR TECHNICAL DATA AND DESIGNS CONTAINED HEREIN ARE PROPRIETARY DATA AND EXCLUSIVE PROPERTY OF RSG PRODUCTS INC. AND IS DELIVERED ON THE EXPRESS CONDITION THAT NEITHER THIS DOCUMENT NOR THE INFORMATION CONTAINED HEREIN SHALL BE DISCLOSED TO OTHERS, REPRODUCED IN WHOLE OR IN PART, OR USED FOR THE MANUFACTURE OR FABRICATION OF PARTS FOR ANYONE OTHER THAN RSG PRODUCTS INC. WITHOUT WRITTEN CONSENT AND AUTHORIZATION, AND THAT NO RIGHT IS GRANTED TO DISCLOSE OR SO USE ANY INFORMATION CONTAINED IN SAD DOCUMENT. THIS RESTRICTION DOES NOT LIMIT THE RIGHT TO USE INFORMATION OBTAINED FROM ANOTHER SOURCE.	NEXT ASSY.	TOLERANCES EXCEPT AS SHOWN
	APPROVED BY: LA	.X: ±.1 .XX: ±.03 .XXX: ±.010 X.X°: ±.5° BREAK ALL SHARP EDGES .01 ALL DIMENSIONS IN INCHES UNLESS OTHERWISE STATED DATE: 10/20/03

TITLE: AFT CONDENSER INSTALLATION				
DRAWN BY: JTYE	DATE: 06/15/03	REV.: B	SCALE: N/A	SHEET: 1 OF 1
APPLICATION: EC 130 B4			DWG. NO.: 7-1-EC130	

REVISION RECORD				
REV	DATE:	DESCRIPTION OF CHANGE	APPVD. BY	REV. BY
A	10/20/03	REVISED INSTRUCTIONS TO INCLUDE HARDWARE OF ALTERNATE LENGTH. REVISED TITLE BLOCK.		JTYE
B	9/1/14	CHANGED TITLE BLOCK AND REVISION BLOCK.		AJC



PRE-INSTALLATION

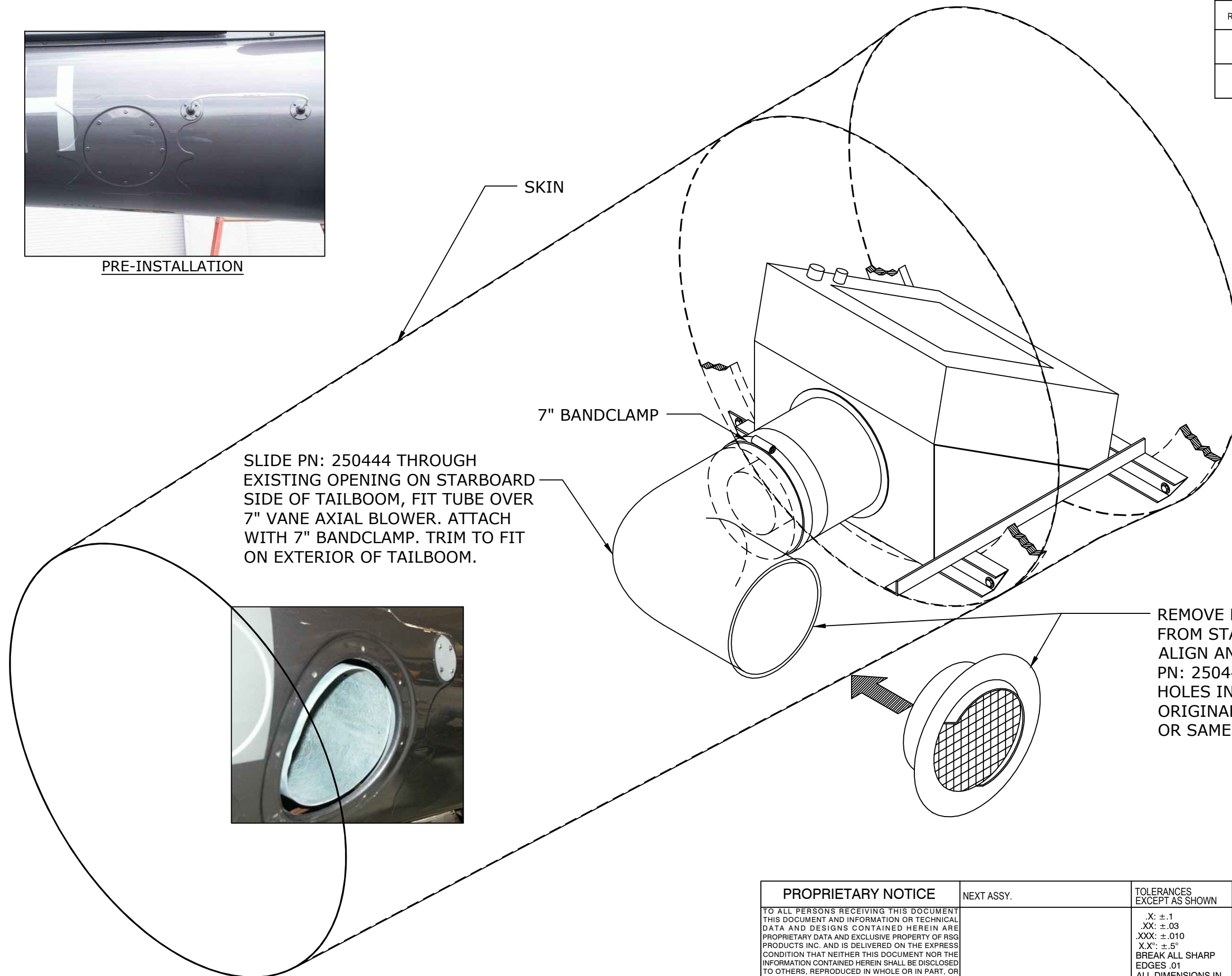

SLIDE PN: 250444 THROUGH EXISTING OPENING ON STARBOARD SIDE OF TAILBOOM, FIT TUBE OVER 7" VANE AXIAL BLOWER. ATTACH WITH 7" BANDCLAMP. TRIM TO FIT ON EXTERIOR OF TAILBOOM.



PROPRIETARY NOTICE TO ALL PERSONS RECEIVING THIS DOCUMENT THIS DOCUMENT AND INFORMATION OR TECHNICAL DATA AND DESIGNS CONTAINED HEREIN ARE PROPRIETARY DATA AND EXCLUSIVE PROPERTY OF RSG PRODUCTS INC. AND IS DELIVERED ON THE EXPRESS CONDITION THAT NEITHER THIS DOCUMENT NOR THE INFORMATION CONTAINED HEREIN SHALL BE DISCLOSED TO OTHERS, REPRODUCED IN WHOLE OR IN PART, OR USED FOR THE MANUFACTURE OR FABRICATION OF PARTS FOR ANYONE OTHER THAN RSG PRODUCTS INC. WITHOUT WRITTEN CONSENT AND AUTHORIZATION, AND THAT NO RIGHT IS GRANTED TO DISCLOSE OR SO USE ANY INFORMATION CONTAINED IN SAD DOCUMENT. THIS RESTRICTION DOES NOT LIMIT THE RIGHT TO USE INFORMATION OBTAINED FROM ANOTHER SOURCE.	NEXT ASSY.	TOLERANCES EXCEPT AS SHOWN		
		.X: ±.1 .XX: ±.03 .XXX: ±.010 X.X": ±.5° BREAK ALL SHARP EDGES .01 ALL DIMENSIONS IN INCHES UNLESS OTHERWISE STATED		TITLE: AFT CONDENSER EXHAUST INSTALLATION
	APPROVED BY:	DATE:	DRAWN BY: JTYE	DATE: 06/15/03
			REV.: B	SCALE: N/A
			SHEET: 1 OF 1	
			APPLICATION: EC 130 B4	
			DWG. NO.: 7-2-EC130	

REVISION RECORD				
REV	DATE	DESCRIPTION OF CHANGE	APPVD. BY	REV. BY
A	10/21/03	REVISED TITLE BLOCK. REDRAWN AS BROKEN OUT VIEW FOR CLARITY.		JTYE
B	9/1/14	CHANGED TITLE BLOCK AND REVISION BLOCK.		AJC

NOTES:

1. CUTOUT EXISTING ACCESS PANEL LEAVING 1" MINIMUM MATERIAL AROUND EDGE.
2. TRIM SCREEN PN: 080040 TO OUTER EDGE OF ACCESS PANEL, BOND TO BACK OF PANEL USING PRO SEAL.
3. REPLACE EXISTING CAMLOCK FASTENERS WITH CAMLOCK 2600-9 OR 10. PAINT TO MATCH AIRCRAFT FINISH.

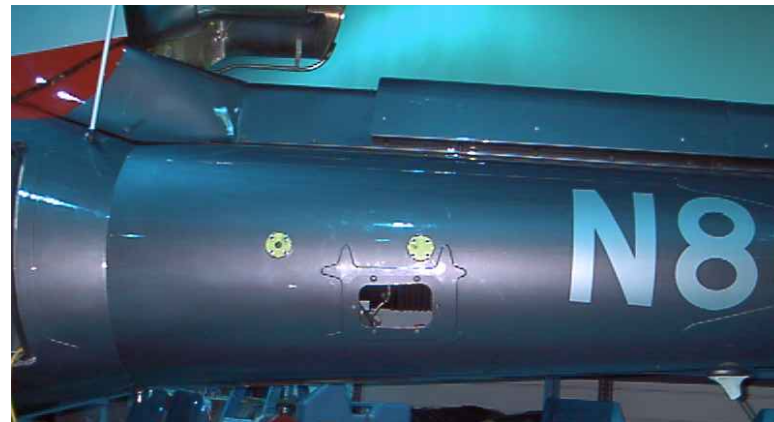
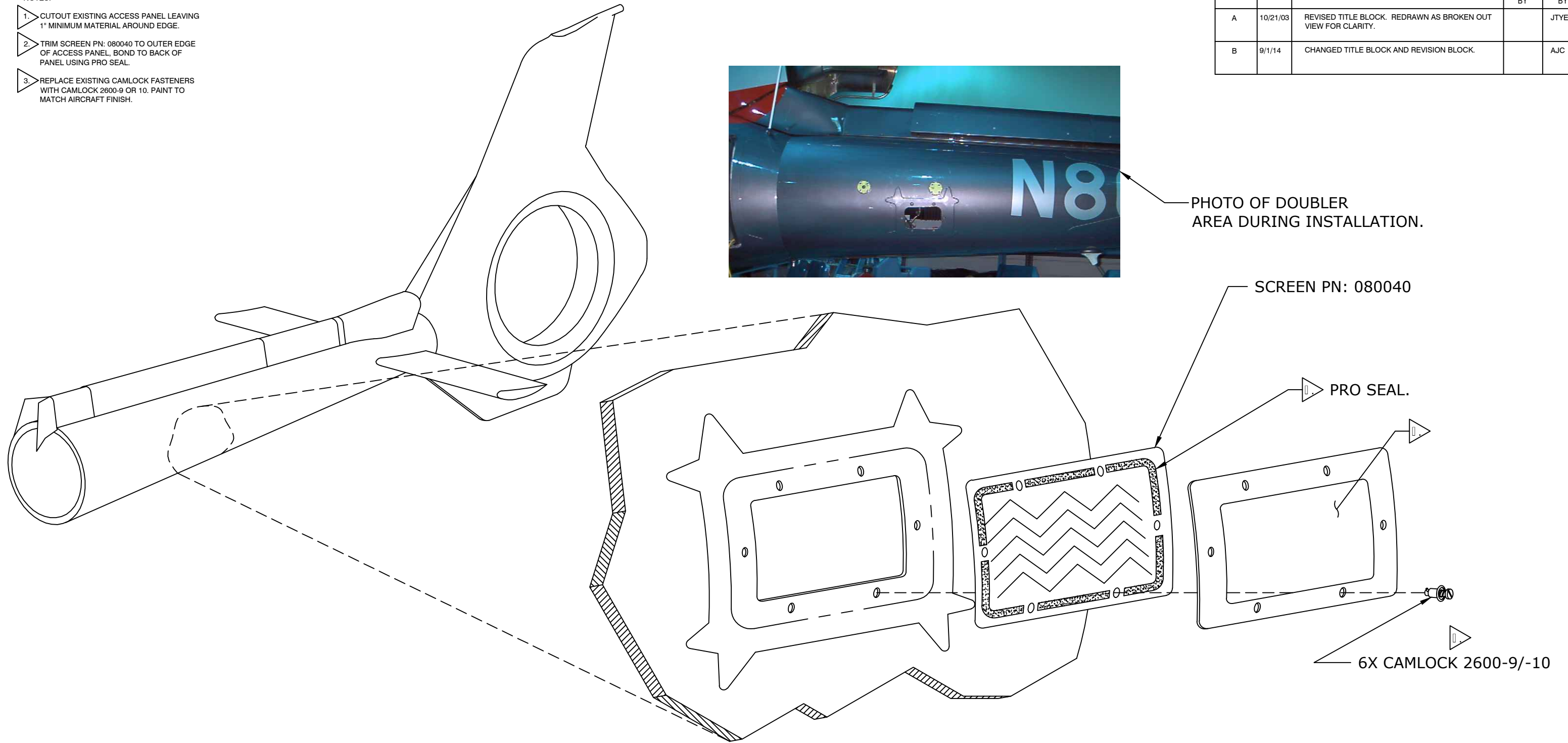

PHOTO OF DOUBLER AREA DURING INSTALLATION.



PROPRIETARY NOTICE TO ALL PERSONS RECEIVING THIS DOCUMENT THIS DOCUMENT AND INFORMATION OR TECHNICAL DATA AND DESIGNS CONTAINED HEREIN ARE PROPRIETARY DATA AND EXCLUSIVE PROPERTY OF RSG PRODUCTS INC. AND IS DELIVERED ON THE EXPRESS CONDITION THAT NEITHER THIS DOCUMENT NOR THE INFORMATION CONTAINED HEREIN SHALL BE DISCLOSED TO OTHERS, REPRODUCED IN WHOLE OR IN PART, OR USED FOR THE MANUFACTURE OR FABRICATION OF PARTS FOR ANYONE OTHER THAN RSG PRODUCTS INC. WITHOUT WRITTEN CONSENT AND AUTHORIZATION, AND THAT NO RIGHT IS GRANTED TO DISCLOSE OR SO USE ANY INFORMATION CONTAINED IN SAD DOCUMENT. THIS RESTRICTION DOES NOT LIMIT THE RIGHT TO USE INFORMATION OBTAINED FROM ANOTHER SOURCE.	NEXT ASSY.	TOLERANCES EXCEPT AS SHOWN		
		.X: ±.1 .XX: ±.03 .XXX: ±.010 X.X": ±.5° BREAK ALL SHARP EDGES .01 ALL DIMENSIONS IN INCHES UNLESS OTHERWISE STATED		TITLE: INSTALLATION AIR INLET DOUBLER
	APPROVED BY:	DATE:		DRAWN BY: JTYE DATE: 06/15/03 REV.: B SCALE: N/A SHEET: 1 OF 1
				APPLICATION: EC130 B4 DWG. NO.: 7-3-EC130

Step 7

Installation of Forward Evaporator

Installation of Forward Evaporator

STEP	PROCEDURE	MECH	INSP
7.1	Locate and install nut plate assembly, P/N 510373, on the right inside panel of the forward instrument console using 2 each, P/N CR3212- 4-3, cherry max rivets. (Per Drawing 4-3-EC130 sheet 2 of 2)		
7.2	Position the forward evaporator, P/N 560004, and shim, P/N 261357, match drill the aft mounting flange to the mounting holes in the right side instrument console and nut pate assembly installed in step 7.1. Mount the forward evaporator using five each, P/N AN3-5A, and five each, P/N AN960-10, washers. (Ref photo 701)		
7.3	Locate the forward evaporator vertical support bracket, P/N 260486-1, as shown in drawing 4-3-EC130 sheet 2 of 2. Remove rivet to allow the bracket to lay flat to the aircraft structure. Replace with, P/N CR3212-4-3, cherry max rivet.		
7.4	Remove two existing screws and match drill the aft flange on the forward evaporator support bracket, P/N 260486-1. Mount the bracket using the two original screws removed. (Ref photo 702)		
7.5	Match drill the flange on the forward evaporator support bracket to the forward evaporator lower mount. Locate the left hand lower evaporator mount to the forward mounting hole in the forward evaporator lower mount. Install three each AN3-4A bolts, 6 each AN960-10 washers and 3 each MS21044-N3 nuts. (Ref photo 703)		
7.6	Install the upper and lower evaporator supports, P/N 510379/510380, to the evaporator mount plate P/N 261363 using, 2 each P/N AN3-3A, bolt and 2 each P/N AN960-10 washer. Per Print 4-3-EC130 sheet 1 of 2.		

RSG Products Inc.
INSTALLATION OF FORWARD EVAPORATOR – B4 Air Conditioning

7.7	Drill holes in the forward side of the instrument console using the upper and lower bracket, P/N 510379/510380, as a guide. Install 2 each P/N AN970-3 washer and 2 each AN3-3A bolt inside of console. Install 2 each AN960-10 washer and 2 each P/N 21044-N3 nut outside console. (Ref photo 701) Print 4-3-EC130 sheet 1 of 2.		
7.8	Remove the forward evaporator after locating holes to facilitate hose install.		
7.9	Removed.		
7.10	Install the forward evaporator using the process described in steps 7.3 through 7.7. Per Print 4-3-EC130 sheet 1 of 2. Attach and route drain hose Per Print 4-4-EC130.		

Air Distribution

7.11	Remove two screws from each side of the glare shield.		
7.12	For Air Vent Config. -01: Locate the left air outlet mount, P/N 250447, to the left side of the glare shield as per drawing 5-1-EC130. (Ref photo 704) For Air Vent Config. -02: Locate vent mount p/n: 261335HP per drawing 5-1-EC130.		
7.13	For Air Vent Config. -01: Match drill the left air outlet assembly mounts to the existing glare shield mounting holes. Attach with screws removed from glare shield Per drawing 5-1-EC130. For Air Vent Config. -02: Match drill mount to the glare shield. Attach with screws and locking nut per drawing 5-1-EC130.		
7.14	For Air Vent Config. -01: Install one, bolt, P/N AN3-4A, 2 ea. washer, P/N AN970-3, and nut, P/N MS21083-N3 Per drawing 5-1-EC130. For Air Vent Config. -02: Install 2X AN525-832R8 and 2X MS21042L08 Per drawing 5-1-EC130.		
7.15	For Air Vent Config. -01: Install the left air outlet assembly P/N 500001 using 3X A10K80 rivnuts and 3X AN525-10R7 screws per Print 5-1-EC130. For Air Vent Config. -02: Place left air vent P/N 520156HP flushed with glare shield. Match drill nutplate hole to glare shield. Attach using screw per Print 5-1-EC130.		
7.16	For Air Vent Config. -01: Locate the right air outlet assembly mount, P/N 250448, to the right side of the glare shield as per drawing 5-1-EC130. (Ref photo 705) For Air Vent Config. -02: Locate vent mount p/n: 261335HP per drawing 5-1-EC130.		
7.17	For Air Vent Config. -01: Match drill the right air outlet assembly mount to the existing glare shield mounting holes. Attach with screws removed from glare shield Per drawing 5-1-EC130. For Air Vent Config. -02: Match drill mount to the glare shield. Attach with screws and locking nut per drawing 5-1-EC130.		
7.18	For Air Vent Config. -01: Install 1X bolt, P/N AN3-4A, 2X washer, P/N AN970-3, and 1X nut, P/N MS21083-N3 Per drawing 5-1-EC130. For Air Vent Config. -02: Install 2X AN525-832R8 and 2X MS21042L08 Per drawing 5-1-EC130.		

RSG Products Inc.
 INSTALLATION OF FORWARD EVAPORATOR – B4 Air Conditioning

STEP	PROCEDURE	MECH	INSP
7.19	For Air Vent Config. -01: Install the right air outlet assembly P/N 500002 using 3X A10K80 rivnuts and 3X AN525-10R7 screws per Print 5-1-EC130. For Air Vent Config. -02: Place left air vent P/N 520157HP flushed with glare shield. Match drill nutplate hole to glare shield. Attach using screw per Print 5-1-EC130.		
7.20	Install 2 ½ inch flex hose from the outlets on the forward evaporator fan to the inlets on the left and right air outlets secure each end with a 3 inch band clamp. (Ref photo 706) Print 5-2-EC130.		
7.21	Install closeout skirt panels, P/N 110018 & P/N 110019 Per Print 4-3-EC130.		

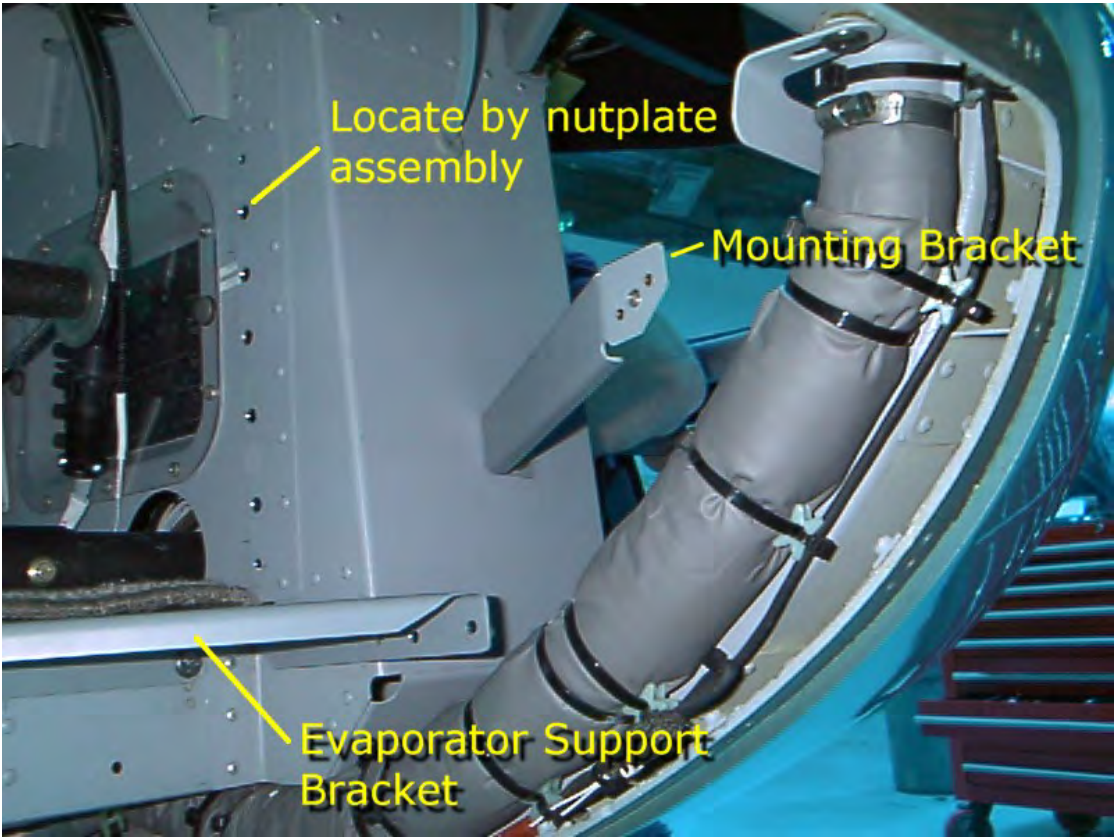

Photo 701

Forward Evaporator
Mounting Holes

RSG Products Inc.
INSTALLATION OF FORWARD EVAPORATOR– B4 Air Conditioning

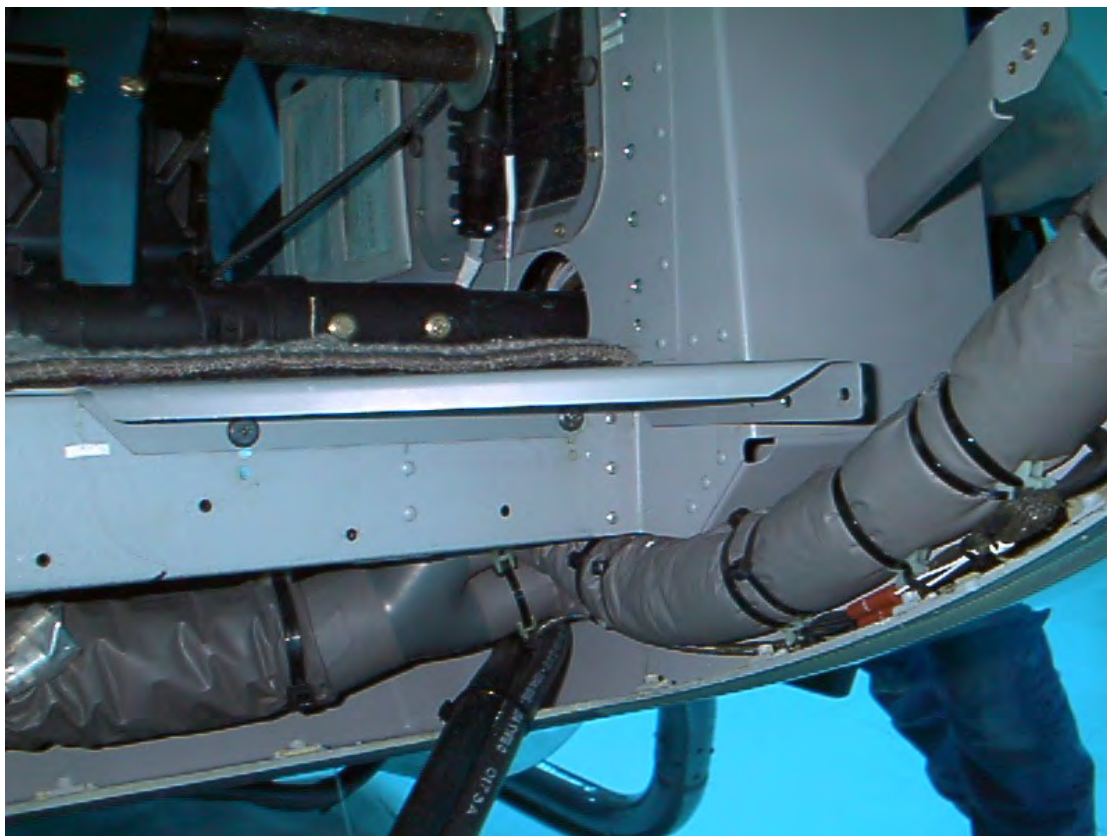

Photo 702

Forward Evaporator
Lower Support

RSG Products Inc.
INSTALLATION OF FORWARD EVAPORATOR– B4 Air Conditioning

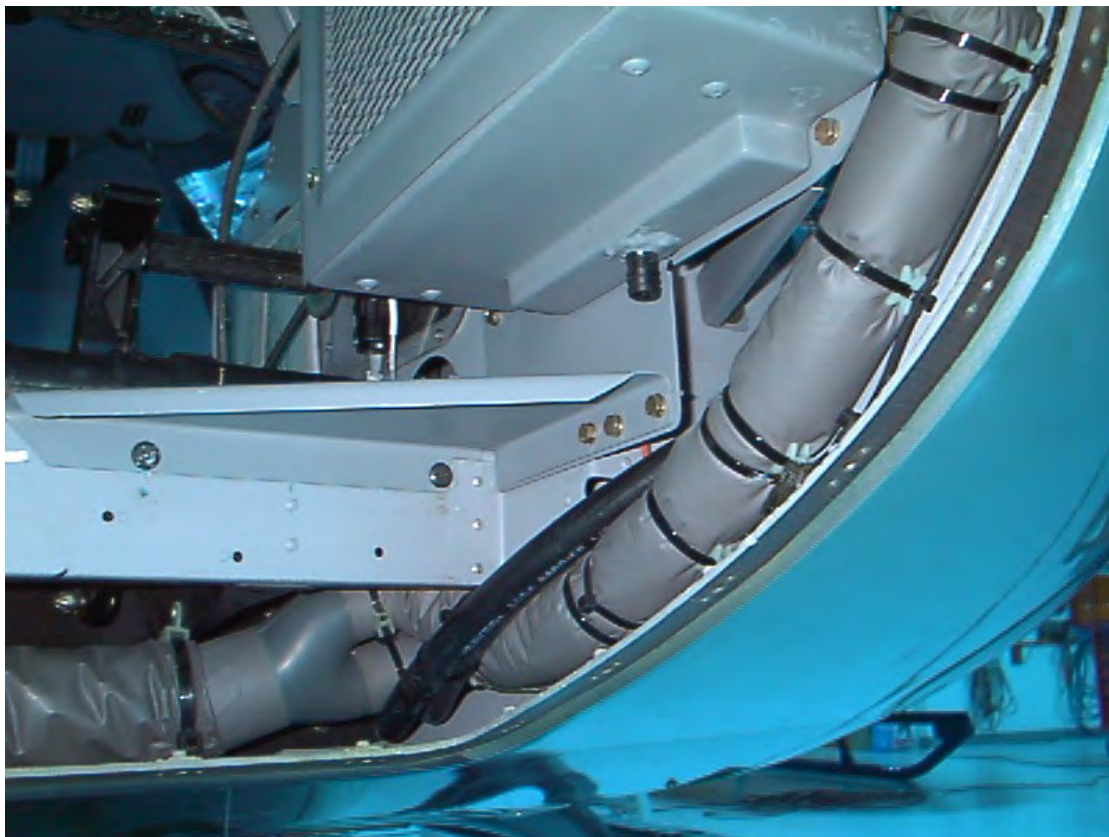

Photo 703

Forward Evaporator
Mounting

RSG Products Inc.
INSTALLATION OF FORWARD EVAPORATOR– B4 Air Conditioning

Photo 704

Left Hand Side Air Outlet
Mounting



RSG Products Inc.
INSTALLATION OF FORWARD EVAPORATOR– B4 Air Conditioning

Photo 705

Connecting Air Tubes For
Forward Air Outlets.

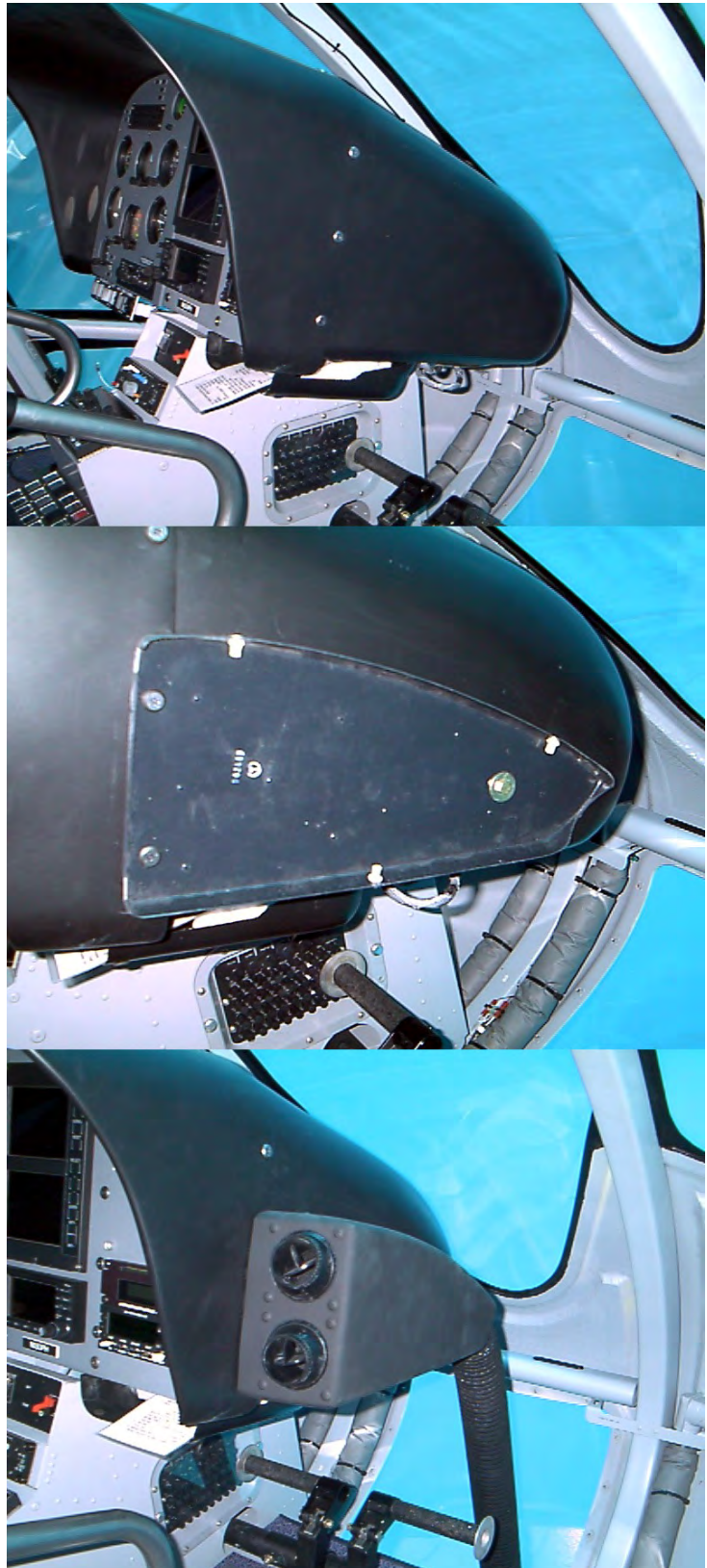

RSG Products Inc.
INSTALLATION OF FORWARD EVAPORATOR– B4 Air Conditioning

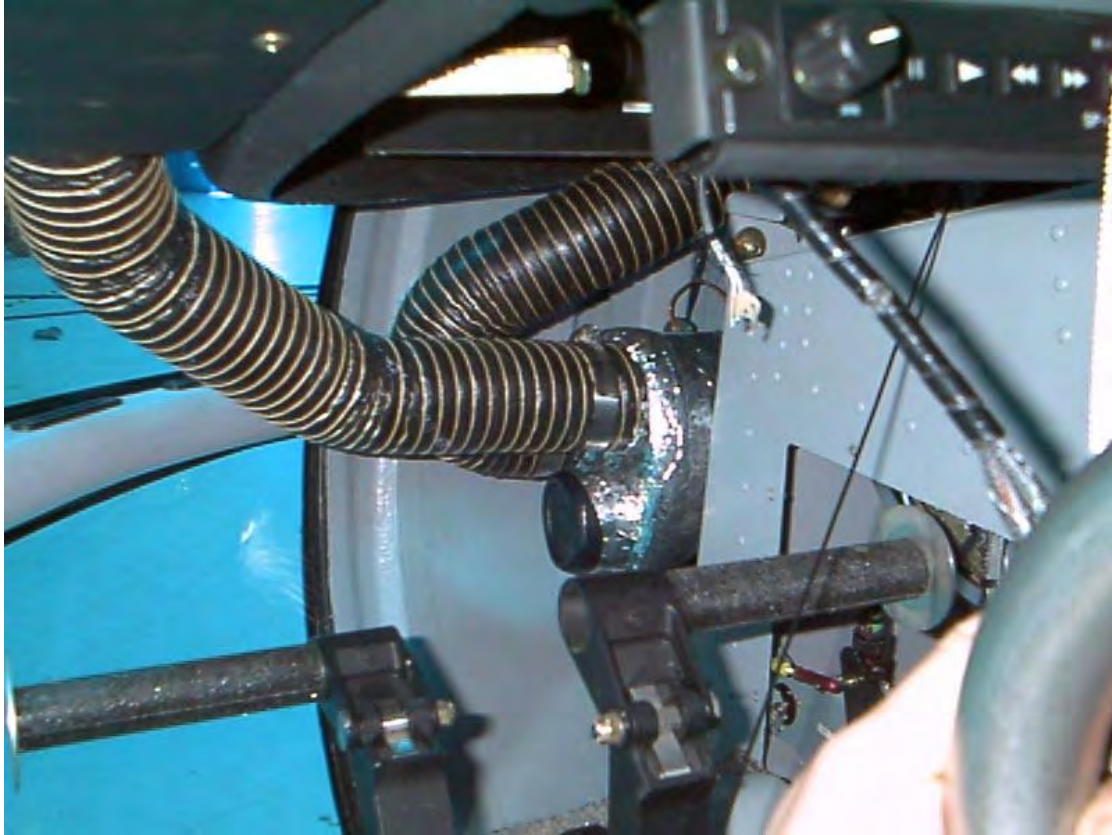

Photo 706

Connecting Air Tubes For
Forward Air Outlets.

REVISION RECORD				
REV	DATE	DESCRIPTION OF CHANGE	APPVD. BY	REV. BY
A	02/10/04	REVISED TITLE BLOCK. ADDED DETAIL "A" AND DIMENSIONS FOR CLARITY. MOVED RESISTOR PN.; IS NOW 540020. ADDED NOTE ABOUT HAND FORMING, CHANGED BOLT CALL OUT FROM: 2X AN3-5 TO: 2X AN3-3A AND FROM: 3X AN3-5A TO: 3X AN3-4A PER ECO 0101. ADDED AN970-3 WASHERS AND MS21044-N3 NUTS.	LA	GB
B	9/1/14	CHANGED TITLE BLOCK AND REVISION BLOCK. INCORPORATED ECO # 0553.	-	AJC

NOTES:
MINOR HAND FORMING MAY BE NEEDED TO OBTAIN A FLUSH FIT FOR FASTENERS.

LOCATE PN: 510379 (BRACKET). MATCH DRILL PN: 261363 (EVAP MNT PLATE) TO HOLE. LOCATE BRACKET TO PEDESTAL, MATCH DRILL PEDESTAL TO BRACKET. (REPEAT PROCESS FOR LOWER BRACKET, PN: 510380) ATTACH EA. BRACKET WITH -
4X AN3-3A BOLT
2X AN970-3 WASHER
2X MS21044-N3 NUT
2X AN970-3 WASHER

FORWARD EVAPORATOR ASSEMBLY PN: 560004.

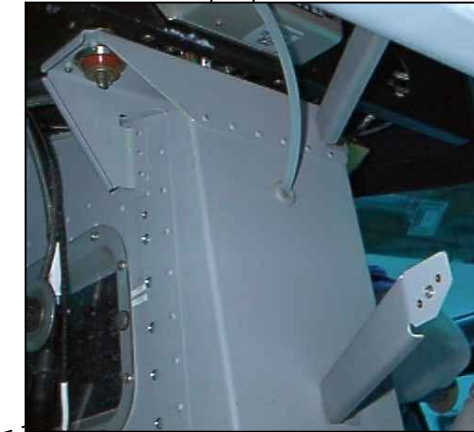

TRIM TO FIT AND INSTALL PN: 110018 INNER CLOSEOUT SKIRT. MATCH DRILL AND ATTACH WITH EXISTING HARDWARE.



VIEW OF ACTUAL INSTALL

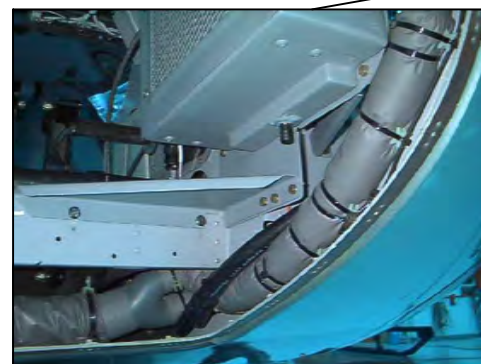

LOCATE PN: 260486-1 (SUPPORT). MATCH DRILL TO EXISTING HOLES IN AIRFRAME. ATTACH WITH ORIGINAL HARDWARE. LOCATE AND DRILL PN: 260486-1 (SUPPORT) TO PN: 261363 (EVAP MNT PLATE) AND ATTACH WITH
3X AN3-4A BOLT
6X AN960-10 WASHER
3X MS21044N3 NUT

OPTIONAL INSTALL FOR NOISE REDUCTION WHEN BRUSHLESS MOTORS ARE INSTALLED; P/Ns: IFSS 050143 DCB, -1 DCB, -2 DCB, AND -3 DCB.
INSTALL THE FOLLOWING, MAINTAINING BURNISHING REQ:
13619-RF16883 (EMI FILTER) 2EA
MS27039-0807 (SCREW) 4EA
NAS620-8L (WASHER) 4EA

BURNISHING REQUIREMENTS:
REMOVE PROTECTIVE FINISH LOCALLY FROM SURFACES WHERE EQUIPMENT MOUNTING HOLES ARE LOCATED, TO ASSURE A PROPER ELECTRICAL BOND MEASURING A MAXIMUM OF 2.5 MILLIOHMS.

PROPRIETARY NOTICE TO ALL PERSONS RECEIVING THIS DOCUMENT THIS DOCUMENT AND INFORMATION OR TECHNICAL DATA AND DESIGNS CONTAINED HEREIN ARE PROPRIETARY DATA AND EXCLUSIVE PROPERTY OF RSG PRODUCTS INC. AND IS DELIVERED ON THE EXPRESS CONDITION THAT NEITHER THIS DOCUMENT NOR THE INFORMATION CONTAINED HEREIN SHALL BE DISCLOSED TO OTHERS, REPRODUCED IN WHOLE OR IN PART, OR USED FOR THE MANUFACTURE OR FABRICATION OF PARTS FOR ANYONE OTHER THAN RSG PRODUCTS INC. WITHOUT WRITTEN CONSENT AND AUTHORIZATION, AND THAT NO RIGHT IS GRANTED TO DISCLOSE OR SO USE ANY INFORMATION CONTAINED IN SAD DOCUMENT. THIS RESTRICTION DOES NOT LIMIT THE RIGHT TO USE INFORMATION OBTAINED FROM ANOTHER SOURCE.	NEXT ASSY.	TOLERANCES EXCEPT AS SHOWN	
	4-3-EC130 SH 2 OF 2	.X: ±.1 .XX: ±.03 .XXX: ±.010 X.X°: ±.5° BREAK ALL SHARP EDGES .01 ALL DIMENSIONS IN INCHES UNLESS OTHERWISE STATED	
	APPROVED BY:	DATE:	TITLE: FORWARD EVAPORATOR INSTALL
			DRAWN BY: JTYE DATE: 06/15/03 REV.: B SCALE: N/A SHEET: 1 OF 2 APPLICATION: EC 130 B4 DWG. NO.: 4-3-EC130

ALIGN EDGE OF PN: 510373 TO SIT FLUSH ON BACKSIDE OF PANEL (NOT ON OVERLAPPED SKIN) AND FLUSH BOTTOM TO FLOOR. MATCH DRILL TO INSTRUMENT PEDESTAL. ATTACH AT EACH END WITH 2X CR3212-4-3 RIVET.

MATCH DRILL PN: 261357 (MOUNT SHIM) AND PN: 261363 (MOUNT PLATE) TO HOLES IN INSTRUMENT PEDESTAL, ALIGN SHIM TO BE FLUSH WITH PLATE, AND ATTACH WITH 5X AN3-5A BOLT 5X AN960-10 WASHER

REPLACE EXISTING BUTTON HEAD RIVET WITH FLUSH HEAD CCR3212-4-03 RIVET, (TOP RIVET ONLY).

TRIM TO FIT AND INSTALL PN: 110019 OUTER CLOSEOUT SKIRT. MATCH DRILL AND ATTACH WITH EXISTING HARDWARE.

AFTER MOUNT PLATE IS INSTALLED, MATCH DRILL PN: 260486-1 SUPPORT TO AIRFRAME, LOCATE AND DRILL 3X #10 HOLES IN TAB AND PN: 261363 MOUNT PLATE. ATTACH TO MOUNT PLATE WITH- 3X AN3-4A BOLT 6X AN960-10 WASHER 3X MS21044N3 NUT SECURE TO EXISTING AIRFRAME WITH ORIGINAL HARDWARE REMOVED FOR DRILLING.

REMOVE AND MATCH DRILL PN:260486-1. TRIM REAR TAB AROUND PEDESTAL TAB IN THE RIGHT CORNER. TOP OF PLATE FLUSH WITH TOP OF DECK.

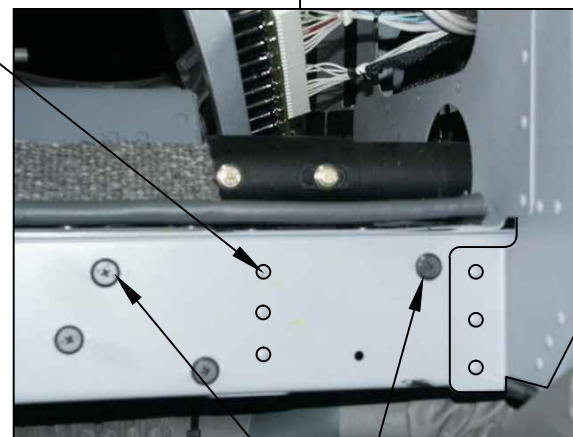
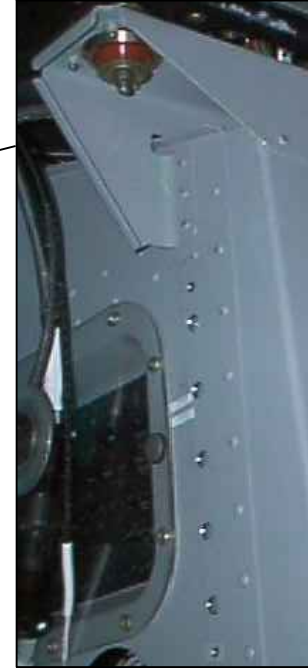

TITLE: FORWARD EVAPORATOR INSTALL				
DRAWN BY: JT YE	DATE: 06/15/03	REV.: B	SCALE: N/A	SHEET: 2 OF 2
APPLICATION: EC 130 B4			DWG. NO.: 4-3-EC130	

REVISION RECORD				
REV	DATE	DESCRIPTION OF CHANGE	APPVD. BY	REV. BY
A	9/1/14	CHANGED TITLE BLOCK AND REVISION BLOCK.	-	AJC

NOTES:

1. DIMENSIONS ARE FOR REFERENCE ONLY. VERIFY BEFORE DRILLING THAT THE PATH FOR THE DRILL BIT IS CLEAR OF OBSTRUCTIONS SUCH AS THE AIRCRAFT FRAME, OR MODIFICATIONS ALREADY EXISTING ON THE AIRCRAFT. HOLE SHOULD BE LOCATED TO ENSURE A CLEAR PATH FOR THE DRAIN HOSE.

2. SEE DETAIL "A" TO SHOW ALLOWABLE MODIFICATION TO PN: 260486-1 ON CERTAIN CONFIGURATIONS OF EC130 TO PROVIDE CLEARANCE FOR THE DRAIN TUBE.

DRILL Ø1 1/16" MOUNTING HOLE FOR RG34 GROMMET.

7.5" (REF)

3" (REF)

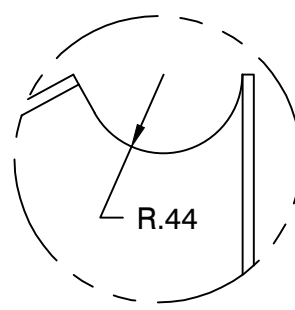

DETAIL "A"

ATTACH TO EVAPORATOR DRAIN WITH ZIP TIE. ROUTING HOSE IN A SIMILAR CONFIGURATION.

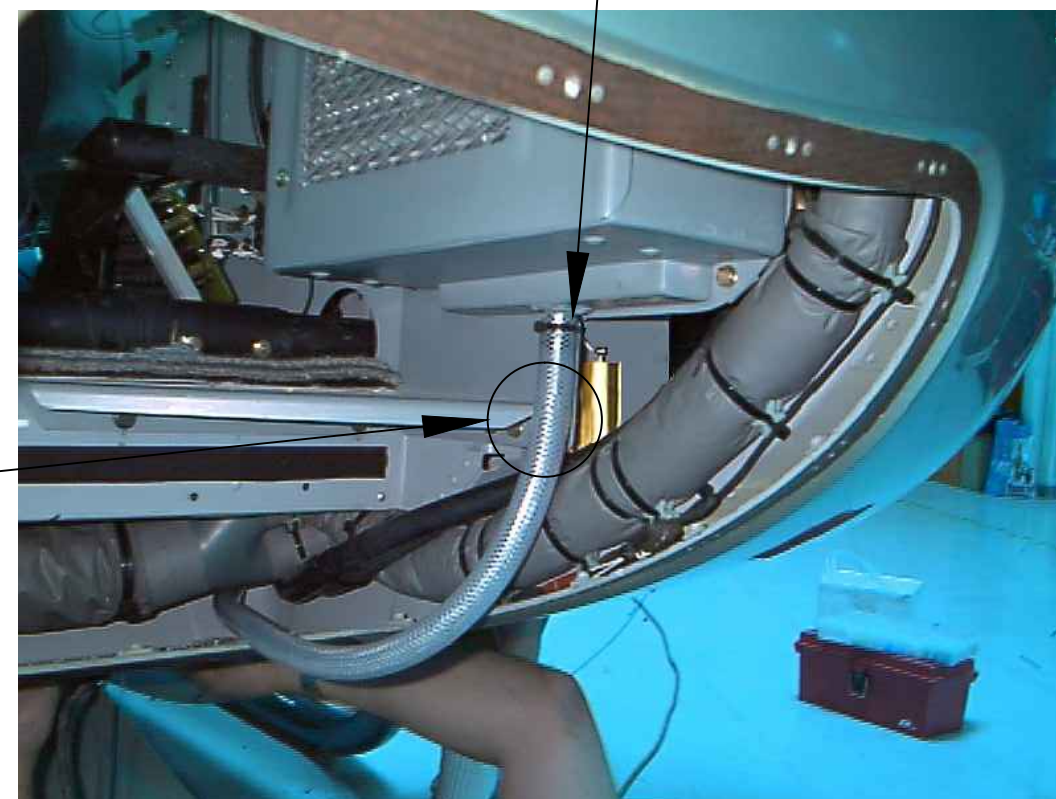

VIEW FROM BOTTOM LOOKING UP



PROPRIETARY NOTICE TO ALL PERSONS RECEIVING THIS DOCUMENT THIS DOCUMENT AND INFORMATION OR TECHNICAL DATA AND DESIGNS CONTAINED HEREIN ARE PROPRIETARY DATA AND EXCLUSIVE PROPERTY OF RSG PRODUCTS INC. AND IS DELIVERED ON THE EXPRESS CONDITION THAT NEITHER THIS DOCUMENT NOR THE INFORMATION CONTAINED HEREIN SHALL BE DISCLOSED TO OTHERS, REPRODUCED IN WHOLE OR IN PART, OR USED FOR THE MANUFACTURE OR FABRICATION OF PARTS FOR ANYONE OTHER THAN RSG PRODUCTS INC. WITHOUT WRITTEN CONSENT AND AUTHORIZATION, AND THAT NO RIGHT IS GRANTED TO DISCLOSE OR SO USE ANY INFORMATION CONTAINED IN SAD DOCUMENT. THIS RESTRICTION DOES NOT LIMIT THE RIGHT TO USE INFORMATION OBTAINED FROM ANOTHER SOURCE.	NEXT ASSY.	TOLERANCES EXCEPT AS SHOWN						
			.X: ±.1 .XX: ±.03 .XXX: ±.010 X.X°: ±.5° BREAK ALL SHARP EDGES .01 ALL DIMENSIONS IN INCHES UNLESS OTHERWISE STATED	TITLE: FWD DRAIN HOSE INSTALLATION				
	APPROVED BY:		DATE:	DRAWN BY: JTYE	DATE: 10/28/03	REV.: A	SCALE: N/A	SHEET: 1 OF 1
				APPLICATION: EC 130 B4			DWG. NO.: 4-4-EC130	

REVISION RECORD				
REV	DATE	DESCRIPTION OF CHANGE	APPVD. BY	REV. BY
A	12/05/03	ADDED ALTERNATE LOCATION AND DWG NOTE.	LA	JTYE
B	05/28/09	REVISED TITLE BLOCK.	MLD	JTYE
C	9/1/14	CHANGED TITLE BLOCK AND REVISION BLOCK.		AJC
D	01/19/22	SHEET 1 FOD NOTE UPDATED TO -01 CONFIG. ADDED SHEET 2 FOR INSTRUMENT PANEL VENT OVERVIEW CONFIG. -02. ADDED SHEET 3 PER ECO 0917.		SGB

-01 AIR OUTLET INSTALLATION
VIEW LOOKING FORWARD AT INSTRUMENT PANEL

ATTACH 500001 TO IFS P/N 250447 AS SHOWN IN VIEW A-A. TRIM TO FIT.

ATTACH 500002 TO IFS P/N 250448 AS SHOWN IN VIEW A-A. TRIM TO FIT.

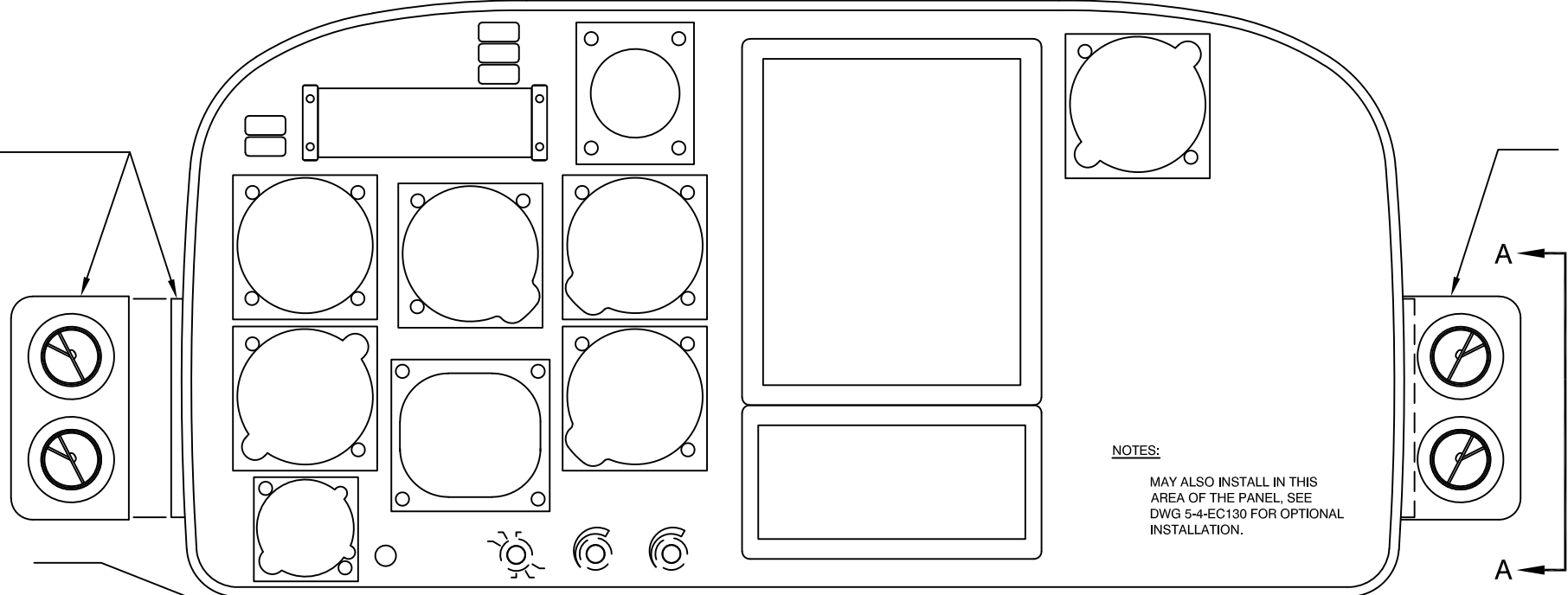

NOTES:
MAY ALSO INSTALL IN THIS AREA OF THE PANEL. SEE DWG 5-4-EC130 FOR OPTIONAL INSTALLATION.

IFS P/N: 540011 LOCATION OPTIONAL.

LOCATE AND DRILL 3X Ø.25 HOLES AND ATTACH WITH 3X A10K80 RIVNUT AND 3X AN52510R7 SCREWS.

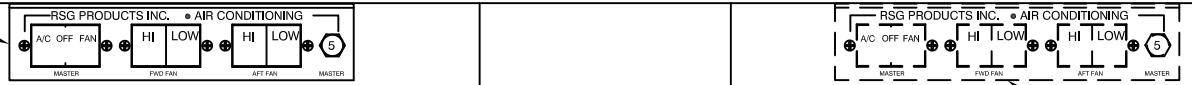

ALTERNATE LOCATION.

REMOVE EXISTING SCREWS FROM MAP BOX ON SIDE OF ATTACHMENT, MATCH DRILL IFS P/N 540011, THEN ATTACH WITH ORIGINAL HARDWARE.

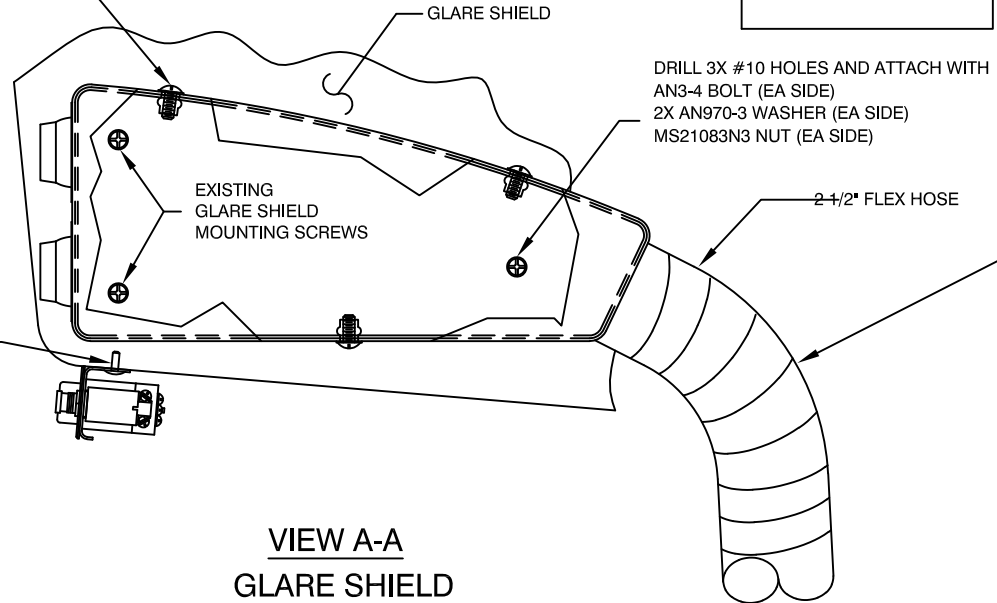

VIEW A-A
GLARE SHIELD

FROM FWD EVAPORATOR

PROPRIETARY NOTICE TO ALL PERSONS RECEIVING THIS DOCUMENT THIS DOCUMENT AND INFORMATION OR TECHNICAL DATA AND DESIGNS CONTAINED HEREIN ARE PROPRIETARY DATA AND EXCLUSIVE PROPERTY OF RSG PRODUCTS INC. AND IS DELIVERED ON THE EXPRESS CONDITION THAT NEITHER THIS DOCUMENT NOR THE INFORMATION CONTAINED HEREIN SHALL BE DISCLOSED TO OTHERS, REPRODUCED IN WHOLE OR IN PART, OR USED FOR THE MANUFACTURE OR FABRICATION OF PARTS FOR ANYONE OTHER THAN RSG PRODUCTS INC. WITHOUT WRITTEN CONSENT AND AUTHORIZATION, AND THAT NO RIGHT IS GRANTED TO DISCLOSE OR SO USE ANY INFORMATION CONTAINED IN SAD DOCUMENT. THIS RESTRICTION DOES NOT LIMIT THE RIGHT TO USE INFORMATION OBTAINED FROM ANOTHER SOURCE.	NEXT ASSY.	TOLERANCES EXCEPT AS SHOWN
	APPROVED BY:	.X: ±.1 .XX: ±.03 .XXX: ±.010 X.X": ±.5° BREAK ALL SHARP EDGES .01 ALL DIMENSIONS IN INCHES UNLESS OTHERWISE STATED

RSG PRODUCTS INC.
A ROTORCRAFT SERVICES GROUP COMPANY

TITLE:
AIR DISTRIBUTION

DRAWN BY: JTYE	DATE: 06/15/03	REV.: D	SCALE: N/A	SHEET: 1 OF 3
APPLICATION: EC 130 B4			DWG. NO.: 5-1-EC130	

-02 AIR OUTLET INSTALLATION
VIEW LOOKING FORWARD AT INSTRUMENT PANEL

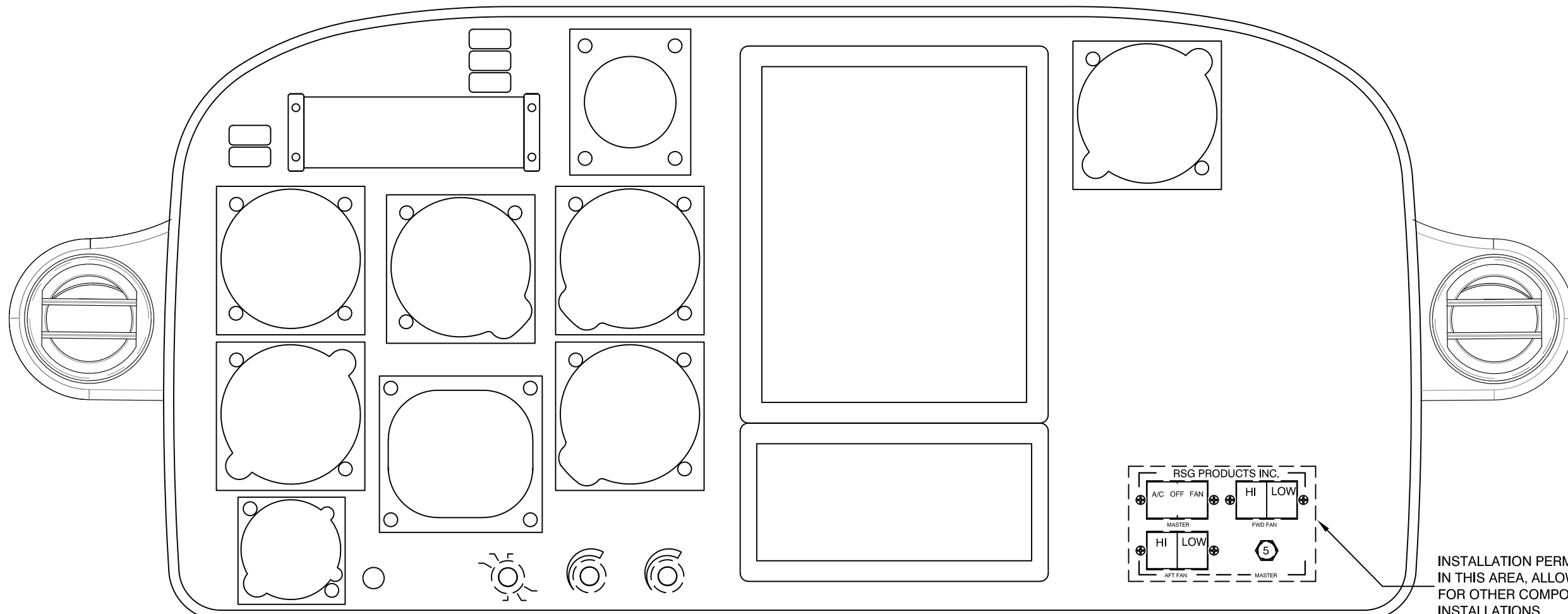

INSTALLATION PERMISSABLE
 IN THIS AREA, ALLOWING
 FOR OTHER COMPONENT
 INSTALLATIONS.

ALTERNATE LOCATION.

IFS P/N: 540011-02
 LOCATION OPTIONAL

IFS P/N: 540011-01



TITLE: AIR DISTRIBUTION				
DRAWN BY: JTYE	DATE: 06/15/03	REV.: D	SCALE: N/A	SHEET: 2 OF 3
APPLICATION: EC 130 B4			DWG. NO.: 5-1-EC130	

8 7 6 5 4 3 2 1

D

D

C

C

B

B

A

A

-02 AIR OUTLET INSTALLATION
VIEW LOOKING FORWARD AT INSTRUMENT PANEL

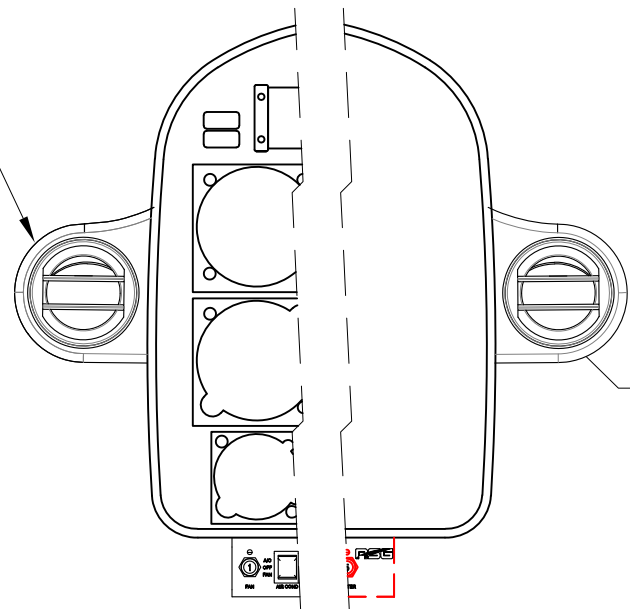

AIR OUTLET ASSY. L.H.
P/N: 520156HP-01
PLACE AIR OUTLET FLUSH WITH
GLARE SHIELD.
SLIDE AIR OUTLET DOWN ONTO
Z MOUNT.
MATCH DRILL NUTPLATE HOLE
TO GLARE SHIELD.
ATTACH USING 1X
AN525-832R8.

AIR OUTLET ASSY. R.H.
P/N: 520157HP-01
PLACE AIR OUTLET FLUSH WITH
GLARE SHIELD.
SLIDE AIR OUTLET DOWN ONTO Z
MOUNT.
MATCH DRILL NUTPLATE HOLE TO
GLARE SHIELD.
ATTACH USING 1X AN525-832R8.

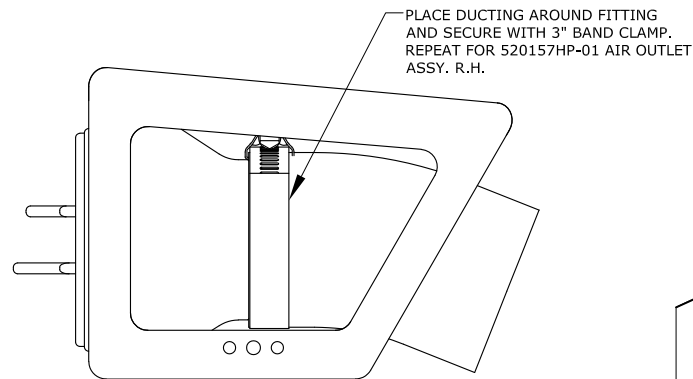

PLACE DUCTING AROUND FITTING
AND SECURE WITH 3" BAND CLAMP.
REPEAT FOR 520157HP-01 AIR OUTLET
ASSY. R.H.

VENT MOUNT P/N: 261335HP-01
LOCATE AS DIMENSIONED.
MATCH DRILL 2X Ø.177 THRU.
ATTACH USING 2X AN525-832R8
AND 2X MS21042L08.
REPEAT FOR RIGHT SIDE
OF GLARE SHIELD.

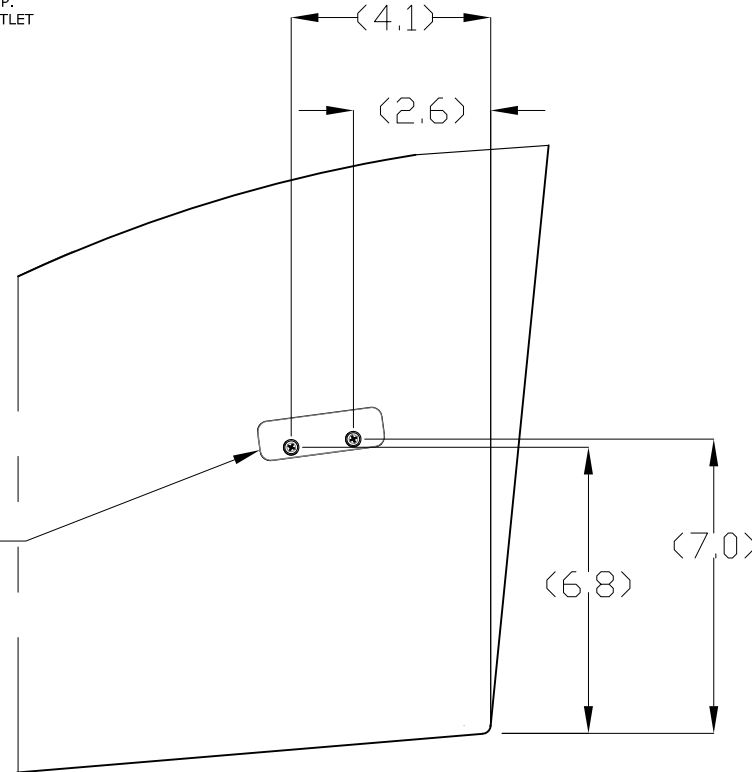

SECTION B-B
GLARE SHIELD HOLE REFERENCE
AIR VENT REMOVED FOR CLARITY
(VENT LOCATION SHOWN AS APPROXIMATE)

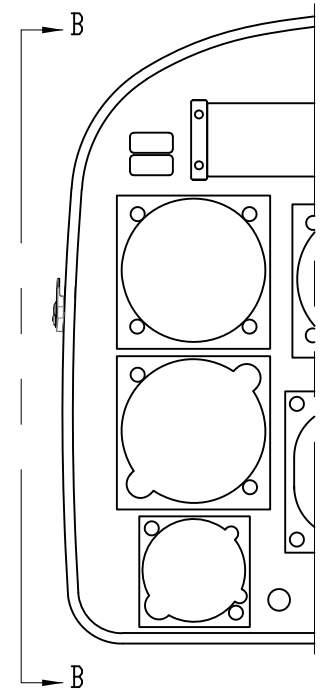

TITLE: AIR DISTRIBUTION				
DRAWN BY: JTYE	DATE: 06/15/03	REV.: D	SCALE: N/A	SHEET: 3 OF 3
APPLICATION: EC 130 B4			DWG. NO.: 5-1-EC130	

8 7 6 5 4 3 2 1

REVISION RECORD				
REV	DATE:	DESCRIPTION OF CHANGE	APPVD. BY	REV. BY
A	05/28/09	REVISED TITLE BLOCK.	MLD	JTYE
B	9/1/14	CHANGED TITLE BLOCK AND REVISION BLOCK.		AJC

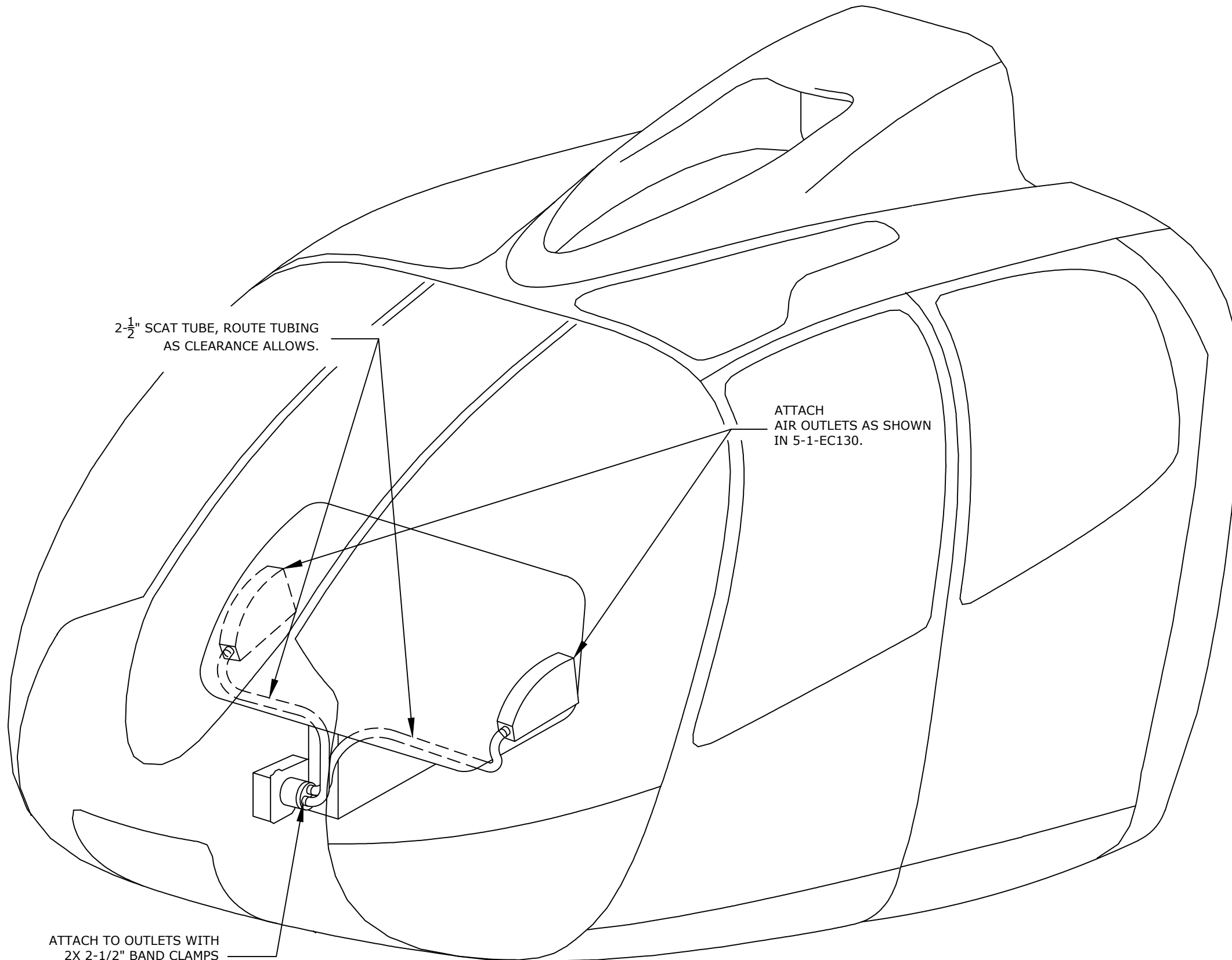

2-1/2" SCAT TUBE, ROUTE TUBING AS CLEARANCE ALLOWS.

ATTACH AIR OUTLETS AS SHOWN IN 5-1-EC130.

ATTACH TO OUTLETS WITH 2X 2-1/2" BAND CLAMPS

PROPRIETARY NOTICE TO ALL PERSONS RECEIVING THIS DOCUMENT THIS DOCUMENT AND INFORMATION OR TECHNICAL DATA AND DESIGNS CONTAINED HEREIN ARE PROPRIETARY DATA AND EXCLUSIVE PROPERTY OF RSG PRODUCTS INC. AND IS DELIVERED ON THE EXPRESS CONDITION THAT NEITHER THIS DOCUMENT NOR THE INFORMATION CONTAINED HEREIN SHALL BE DISCLOSED TO OTHERS, REPRODUCED IN WHOLE OR IN PART, OR USED FOR THE MANUFACTURE OR FABRICATION OF PARTS FOR ANYONE OTHER THAN RSG PRODUCTS INC. WITHOUT WRITTEN CONSENT AND AUTHORIZATION, AND THAT NO RIGHT IS GRANTED TO DISCLOSE OR SO USE ANY INFORMATION CONTAINED IN SAD DOCUMENT. THIS RESTRICTION DOES NOT LIMIT THE RIGHT TO USE INFORMATION OBTAINED FROM ANOTHER SOURCE.	NEXT ASSY.	TOLERANCES EXCEPT AS SHOWN		
		.X: ±.1 .XX: ±.03 .XXX: ±.010 X.X°: ±.5° BREAK ALL SHARP EDGES .01 ALL DIMENSIONS IN INCHES UNLESS OTHERWISE STATED		TITLE: AIR DISTRIBUTION
	APPROVED BY:	DATE:	DRAWN BY: JTYE DATE: 06/15/03 REV.: B SCALE: N/A SHEET: 1 OF 1	APPLICATION: EC 130 B4
			DWG. NO.: 5-2-EC130	

REVISION RECORD				
REV	DATE	DESCRIPTION OF CHANGE	APPVD. BY	REV. BY
A	05/28/09	REVISED TITLE BLOCK. ADDED OPTIONAL SWITCH LOCATION AS SHOWN IN FLIGHT MANUAL SUPPLEMENT.	MLD	JTYE
B	9/1/14	CHANGED TITLE BLOCK AND REVISION BLOCK.		AJC
C	01/19/22	SHEET 1 FOD NOTE UPDATED TO -01 CONFIG. ADDED SHEET 2 FOR INSTRUMENT PANEL VENT OVERVIEW CONFIG. -02. ADDED SHEET 3 PER ECO 0917.		SGB

-01 AIR OUTLET INSTALLATION
VIEW LOOKING FORWARD AT INSTRUMENT PANEL

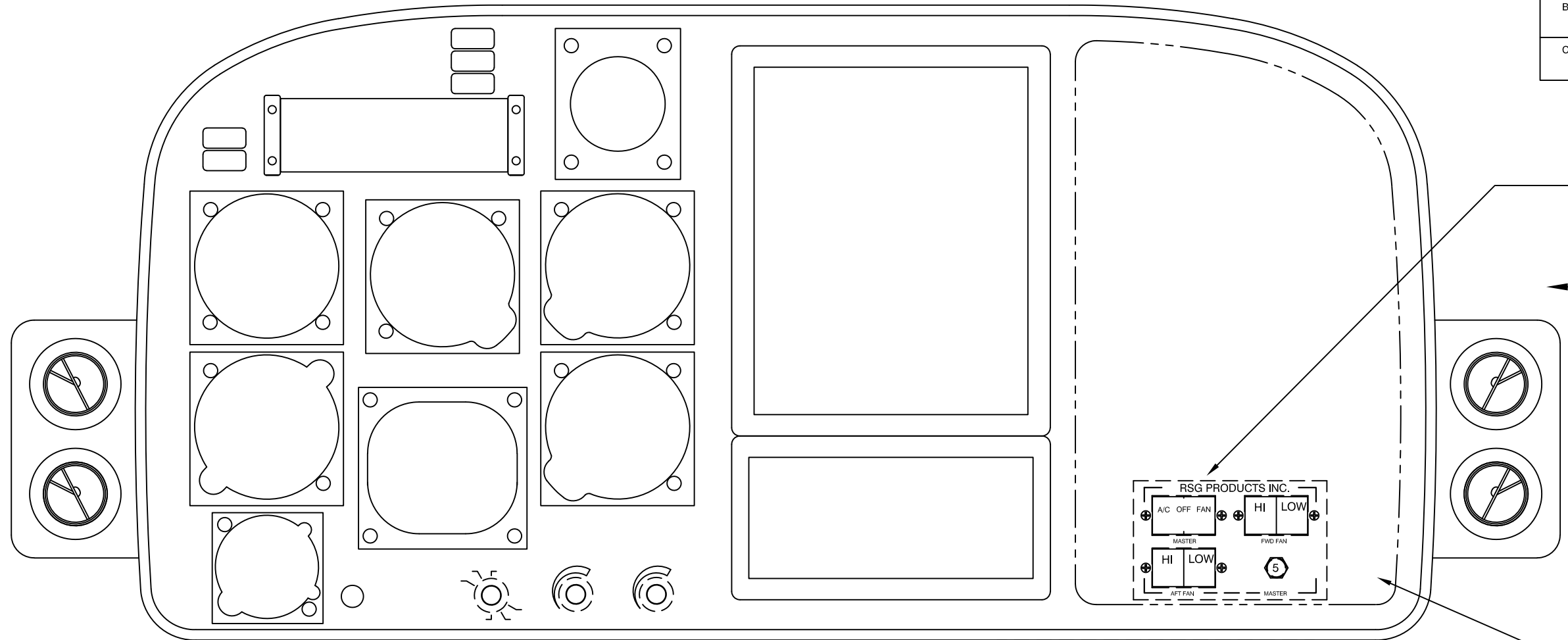

IFS P/N: 120152 LOCATE AS TO NOT OBSTRUCT OTHER INSTRUMENTATION USE PLACARDS AS TEMPLATE FOR DRILLING DO NOT USE PLACARD AS JIG FOR DRILLING.

ATTACH WITH EXISTING HARDWARE FROM PN: 540011.

INSTALLATION PERMISSABLE IN THIS AREA, ALLOWING FOR OTHER COMPONENT INSTALLATIONS.



IFS P/N: 540011
LOCATION OPTIONAL.

REMOVE EXISTING SCREWS FROM MAP BOX ON SIDE OF ATTACHMENT, MATCH DRILL IFS P/N 540011, THEN ATTACH WITH ORIGINAL HARDWARE.

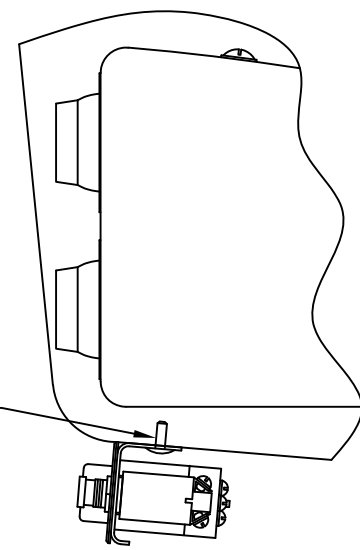

VIEW A-A

PROPRIETARY NOTICE TO ALL PERSONS RECEIVING THIS DOCUMENT THIS DOCUMENT AND INFORMATION OR TECHNICAL DATA AND DESIGNS CONTAINED HEREIN ARE PROPRIETARY DATA AND EXCLUSIVE PROPERTY OF RSG PRODUCTS INC. AND IS DELIVERED ON THE EXPRESS CONDITION THAT NEITHER THIS DOCUMENT NOR THE INFORMATION CONTAINED HEREIN SHALL BE DISCLOSED TO OTHERS, REPRODUCED IN WHOLE OR IN PART, OR USED FOR THE MANUFACTURE OR FABRICATION OF PARTS FOR ANYONE OTHER THAN RSG PRODUCTS INC. WITHOUT WRITTEN CONSENT AND AUTHORIZATION, AND THAT NO RIGHT IS GRANTED TO DISCLOSE OR SO USE ANY INFORMATION CONTAINED IN SAD DOCUMENT. THIS RESTRICTION DOES NOT LIMIT THE RIGHT TO USE INFORMATION OBTAINED FROM ANOTHER SOURCE.	NEXT ASSY.	TOLERANCES EXCEPT AS SHOWN .X: ±.1 .XX: ±.03 .XXX: ±.010 X.X": ±.5° BREAK ALL SHARP EDGES .01 ALL DIMENSIONS IN INCHES UNLESS OTHERWISE STATED		
	APPROVED BY: MLD	DATE: 05/28/09		TITLE: A/C INSTRUMENTATION CONFIGURATIONS
	DRAWN BY: JTYE	DATE: 12/03/03	REV.: C	SCALE: N/A
APPLICATION: EC 130 B4			DWG. NO.: 5-4-EC130	

-02 AIR OUTLET INSTALLATION

VIEW LOOKING FORWARD AT INSTRUMENT PANEL

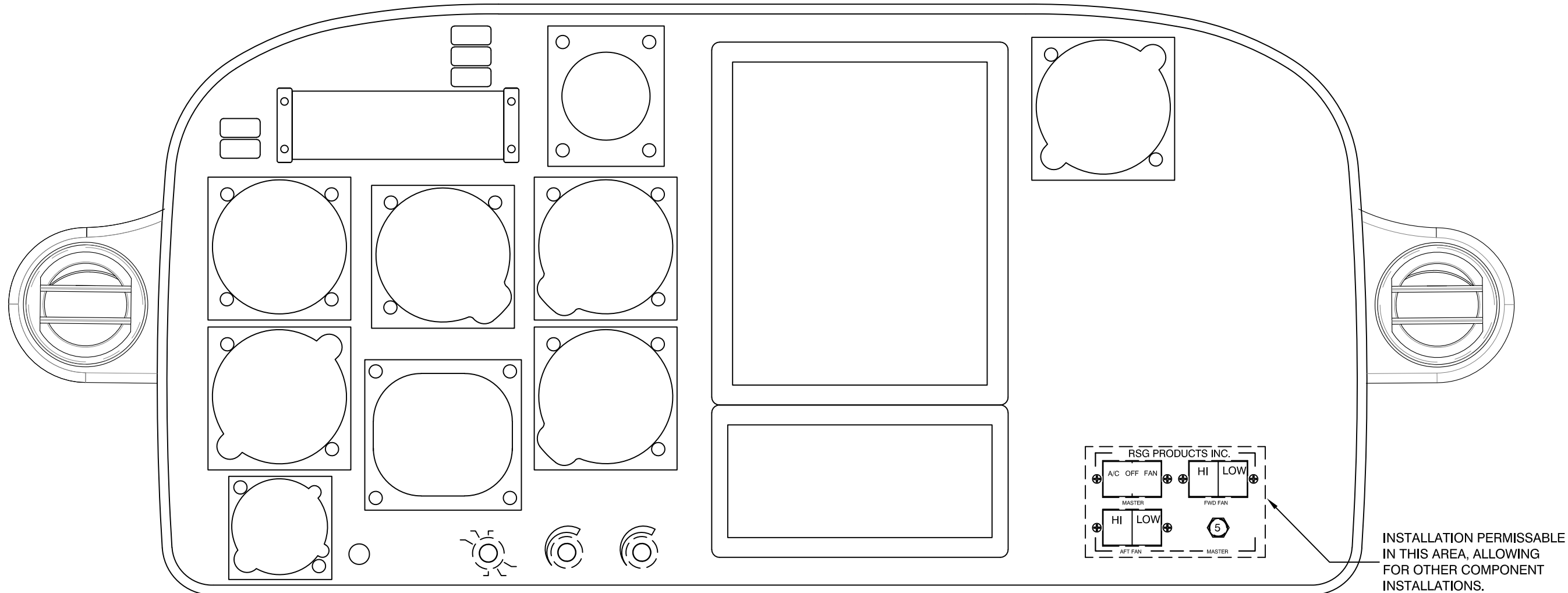

INSTALLATION PERMISSABLE IN THIS AREA, ALLOWING FOR OTHER COMPONENT INSTALLATIONS.

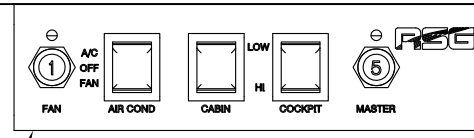

IFS P/N: 540011-02
LOCATION OPTIONAL

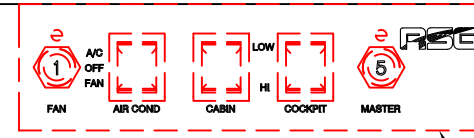

ALTERNATE LOCATION.

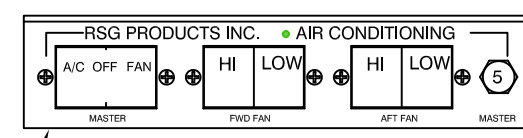

IFS P/N: 540011-01



TITLE: A/C INSTRUMENTATION CONFIGURATIONS				
DRAWN BY: JTYE	DATE: 12/03/03	REV.: C	SCALE: N/A	SHEET: 2 OF 3
APPLICATION: EC 130 B4			DWG. NO.: 5-4-EC130	

-02 AIR OUTLET INSTALLATION
VIEW LOOKING FORWARD AT INSTRUMENT PANEL

AIR OUTLET ASSY. L.H.
P/N: 520156HP-01
PLACE AIR OUTLET FLUSH WITH
GLARE SHIELD.
SLIDE AIR OUTLET DOWN ONTO
Z MOUNT.
MATCH DRILL NUTPLATE HOLE
TO GLARE SHIELD.
ATTACH USING 1X
AN525-832R8.

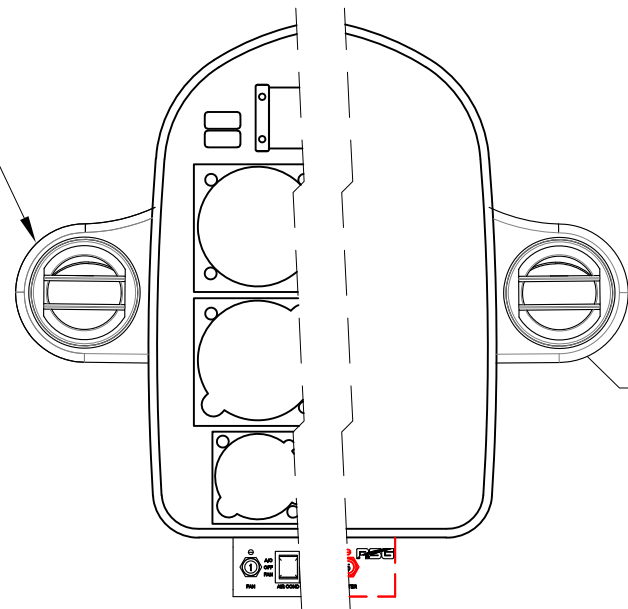

AIR OUTLET ASSY. R.H.
P/N: 520157HP-01
PLACE AIR OUTLET FLUSH WITH
GLARE SHIELD.
SLIDE AIR OUTLET DOWN ONTO Z
MOUNT.
MATCH DRILL NUTPLATE HOLE TO
GLARE SHIELD.
ATTACH USING 1X AN525-832R8.

PLACE DUCTING AROUND FITTING
AND SECURE WITH 3" BAND CLAMP.
REPEAT FOR 520157HP-01 AIR OUTLET
ASSY. R.H.

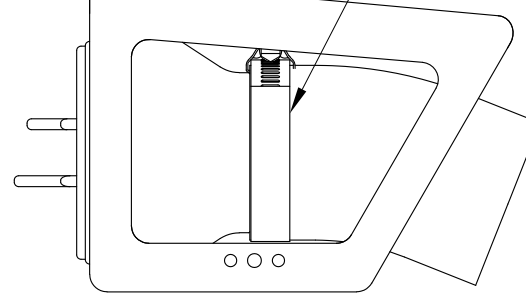

VENT MOUNT P/N: 261335HP-01
LOCATE AS DIMENSIONED.
MATCH DRILL 2X Ø.177 THRU.
ATTACH USING 2X AN525-832R8
AND 2X MS21042L08.
REPEAT FOR RIGHT SIDE
OF GLARE SHIELD.

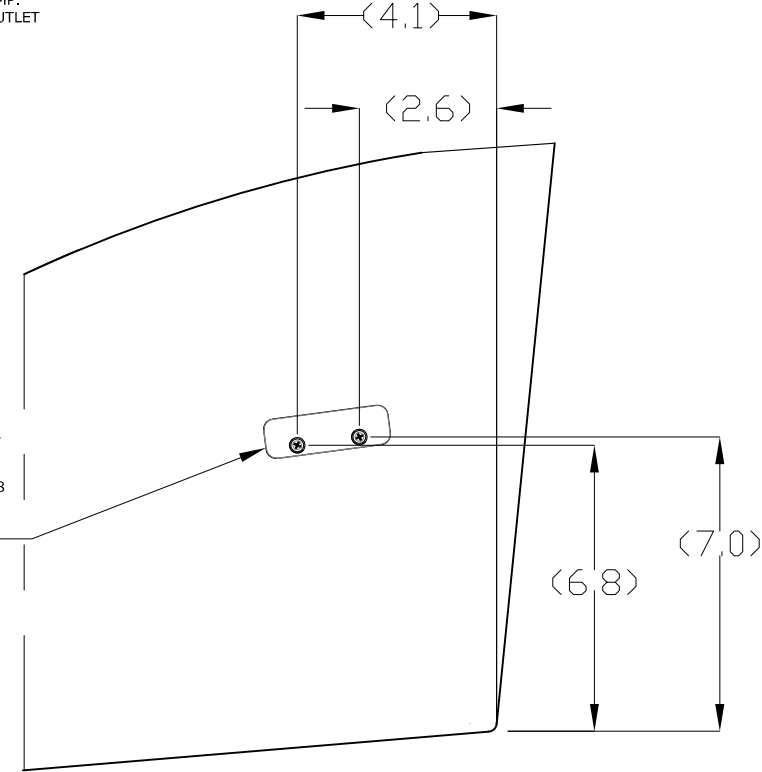

SECTION B-B
GLARE SHIELD REFERENCE
AIR VENT REMOVED FOR CLARITY
(VENT LOCATION SHOWN AS APPROXIMATE)

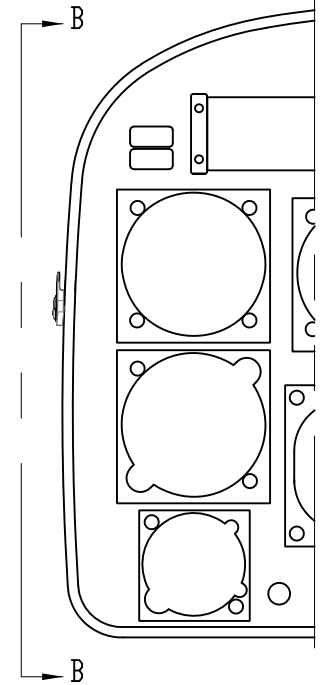

RSG PRODUCTS INC.
A ROTORCRAFT SERVICES COMPANY

TITLE:
A/C INSTRUMENTATION CONFIGURATIONS

DRAWN BY: JT YE	DATE: 12/03/03	REV.: C	SCALE: N/A	SHEET: 3 OF 3
--------------------	-------------------	------------	---------------	------------------

APPLICATION: EC 130 B4	DWG. NO.: 5-4-EC130
---------------------------	------------------------

Step 8

Installation of Compressor

Installation of Compressor

STEP	PROCEDURE	MECH	INSP
8.0	NOTE: MUST BE PERFORMED IN ACCORDANCE WITH CURRENT EUROCOPTER TECHNICAL DATA.		
8.1	Place a support on the transmission deck to support the engine drive while the shaft is disconnected for belt installation.		
8.2	Remove the cotter pins from the four pins holding the “Gimble Ring” at the Thomas coupling.		
8.3	Slide the “Gimble Ring” aft to gain access to the Thomas coupling.		
8.4	Remove the 6 bolts and Thomas coupling connecting the drive shaft and shift slightly aft.		
8.5	Install two (2) Compressor Drive belts, P/N 060005.		
8.6	Reassemble the Thomas coupling per AEC Specifications. Torque and Safety Coupling!! Torque Mark all bolts.		
8.7	Secure 1 belt to the outside of the drive shaft cover for a spare and slip one through the housing and over the drive pulley. NOTE: THE CURRENT BELT HAS NO SPECIFIC DIRECTION OF ROTATION.		
8.8	Install the “Gimble Ring” pins and cotter pins. Remove supports.		
8.9	Installation of Bracket Kit P/N 130-11-031 in accordance with drawing numbers: 6-1-EC130, 6-2-EC130 and 6-3-EC130.		
8.10	Install the forward compressor bracket, P/N 300067-1, and compressor standoffs, P/N 261007 and Compressor P/N 590008-1. Per drawing numbers: 6-1-EC130, 6-2-EC130 and 6-3-EC130.		

Installation of Compressor

STEP	PROCEDURE	MECH	INSP
8.11	Install the compressor drive belt on the drive pulley and the compressor clutch pulley. Tighten bolts at the adjustment arm assuring the belt has approximately 30 pounds of tension. Tighten the lower forward mounting bolt. (Ref photo 802).		
8.12	This tension may be performed by either pull scale or measuring belt deflection.		
8.13	30 lbs pull tension at tension adjustment bolt should provide adequate belt tension. Verify tension .25 inch deflection at mid span of belt with 10 lbs pull on belt. Per drawing number 6-5-EC130.		

RSG Products Inc.
INSTALLATION OF COMPRESSOR– B4 Air Conditioning

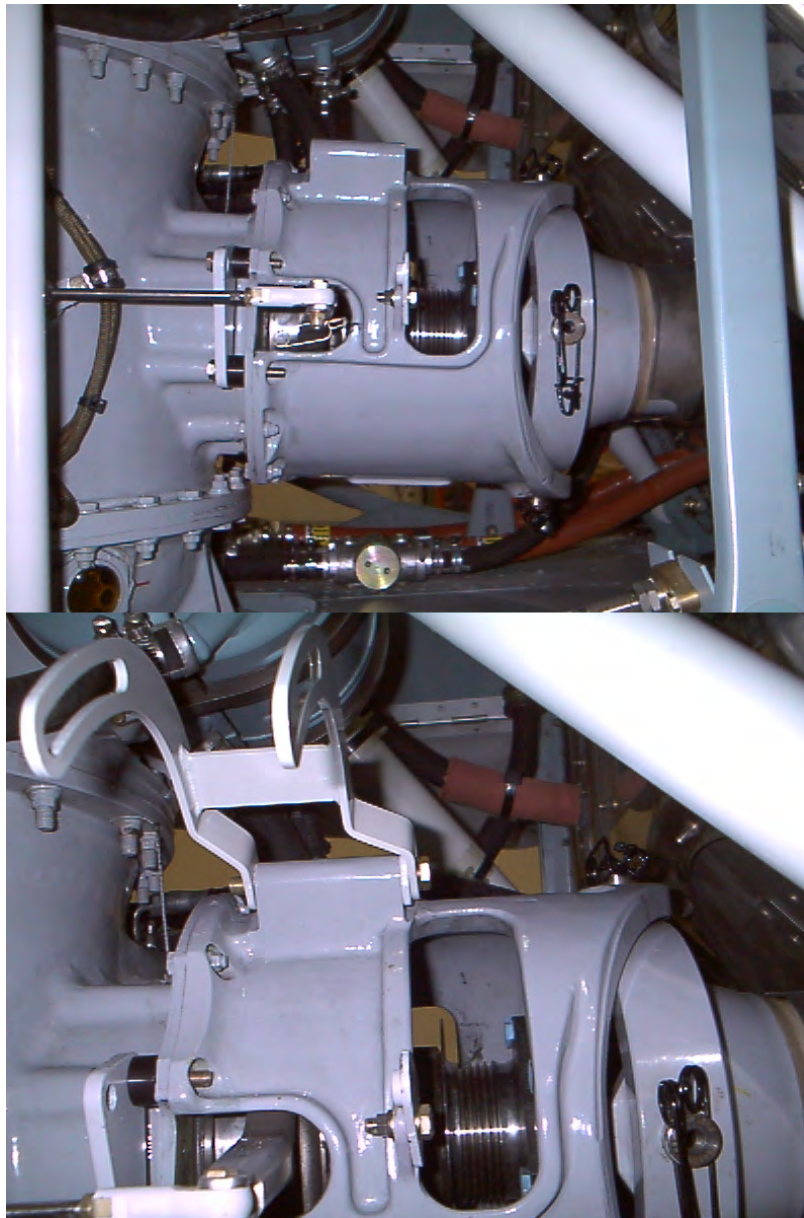

Photo 801

Compressor Bracket
Installation

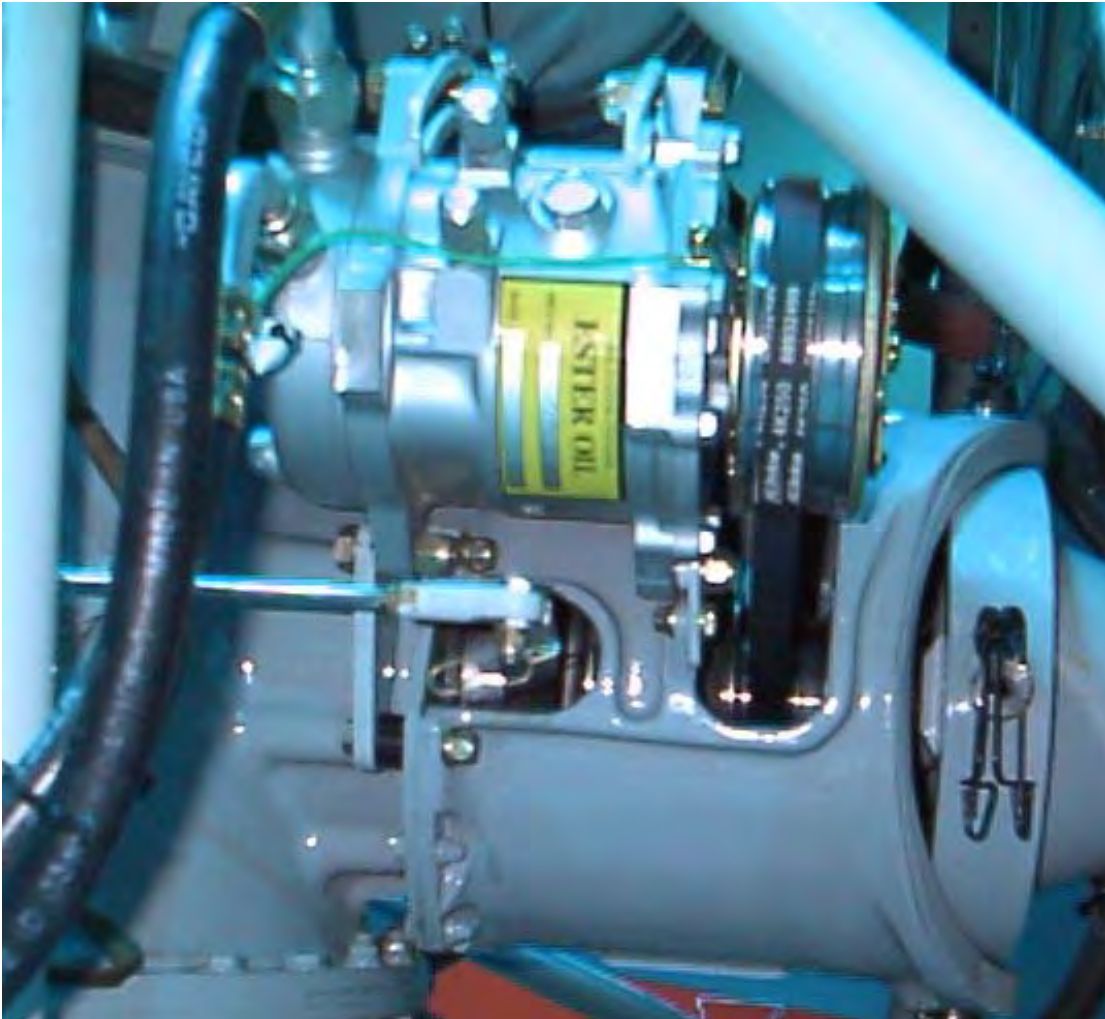
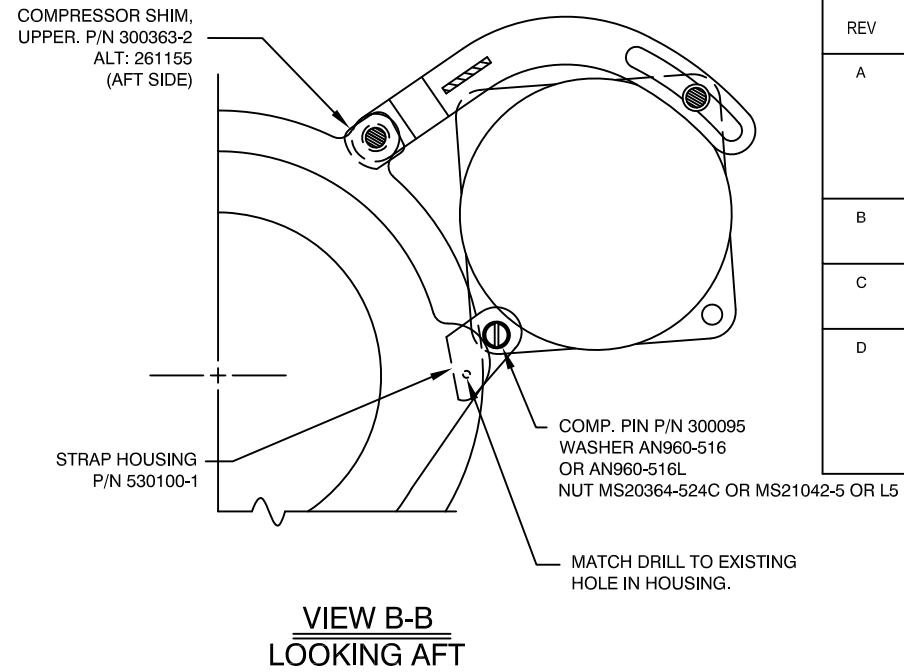
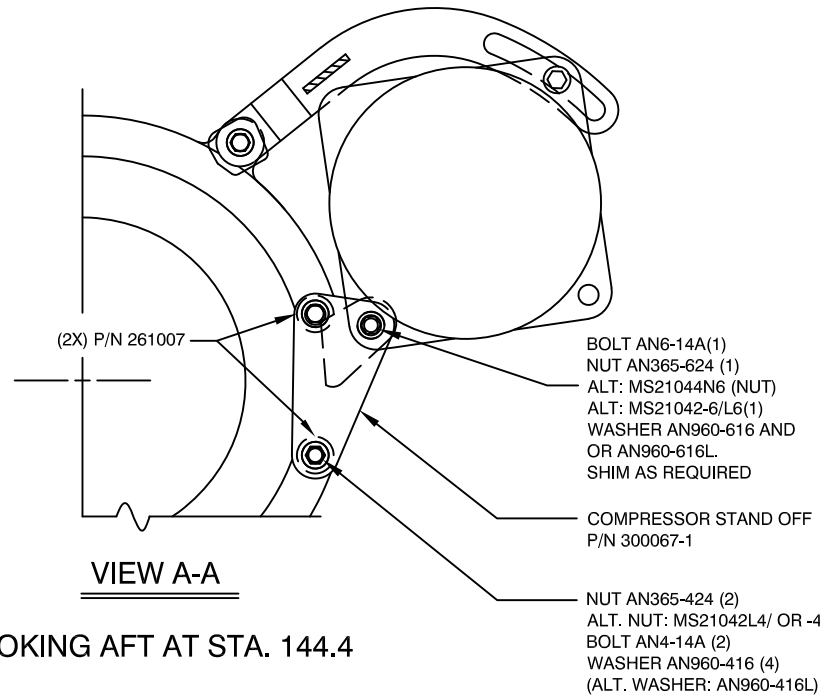

Photo 802

Compressor installation

INSTALLATION INSTRUCTIONS

- 1) THE ABOVE KIT UTILIZES THE COMPRESSOR P/N: 590008-1.
- 2) THE BELT P/N:060005 IS USED IN THIS INSTALLATION.
- 3) THE SAME COMPRESSOR MOUNT ASSEMBLY P/N: 530027-3, PIN P/N: 300095, AND COMPRESSOR STAND OFF P/N: 300067-1 ARE UTILIZED IN ALL INSTALLATIONS.
- 4) THE AFT, INBOARD COMPRESSOR MOUNTING POINT IS RELOCATED FORWARD BY PLACING TWO ALUMINUM "BUSHINGS", P/N: 261007 BETWEEN THE "STAND OFF" P/N: 300067-1 AND THE TRANSMISSION HOUSING. TWO (2) EACH AN4-14A BOLTS MUST BE USED.
- 6) THE FORWARD, UPPER INBOARD COMPRESSOR EAR IS ALIGNED WITH THE COMPRESSOR UNIT ASSEMBLY BY PLACING A "BUSHING", P/N 261008 BETWEEN THE AFT SIDE OF THE EAR AND THE MOUNT ASSEMBLY.
- 7) AN6-12A BOLTS ARE USED TO ENSURE BELT TENSION. A MINIMUM THREAD PROTRUSION ON THE FORWARD UPPER BOLT REQUIRES THAT A STEEL SELF LOCKING NUT P/N: MS20364-624C OR ALTERNATE MUST BE UTILIZED.
- 8) FOR ALTERNATE INSTALL USING 04-130-21-101-01 BRACKET SEE -02 CONFIGURATION ON SHEET 2.
- 9) REAM BUSHING IN 530100-1 STRAP HOUSING FOR PROPER FIT OF 300095 PIN USING REAMING TOOL RANGE (.302-NI TO .3594-23/64).
- 10) AFTER REAMING, USE CORROSION PROTECTANT.



REVISION RECORD				
REV	DATE	DESCRIPTION OF CHANGE	APPVD. BY	REV. BY
A	01/30/06	REVISED PART NO's AND INSTRUCTIONS TO MATCH. INCREASED BOLT LENGTH TO -45. WAS -44. ADDED ALTERNATE COMPRESSOR SHIM PART NO. 261155. DELETED ALTERNATE BELT PN. REMOVED BEVELED EDGE NOTATION. REMOVED ADDITIONAL PN:261007 AT WRONG LOCATION. CHANGED WASHER NOTES PER ECO # 0126.	-	JTYE
B	08/25/09	REVISED TITLE BLOCK. REMOVED ALTERNATE BELT PN: 060006, CHANGED NOTE 2 TO REFLECT ONLY 060005 BELT.	MLD	JTYE
C	09/01/14	CHANGED TITLE BLOCK AND REVISION BLOCK. ADDED ALTERNATE NUMBERS AND CONFIGURATION -02, AND REVISED NOTES PER ECO #'s 0262, 0375, & 0431.		AJC
D	01/19/22	CHANGED POSITION OF COMPRESSOR CLAMP & PARTS ASSOCIATED TO CONFIG. -02 OF DRAWING NO. 6-1-EC130. DEPICT CHANGES TO DETAIL B. DEPICT CHANGES TO SECTION C-C. DEPICT CHANGES TO SECTION D-D. DEPICT CHANGES TO VIEW G-G. BUBBLE CALL OUTS REFERENCING DRAWING NUMBER 6-1-EC130: ITEMS 15, 26 AND 24. ADD ALT. PN FOR ITEM 23 TO BOM PER ECO 0720 & 0941.		SGB

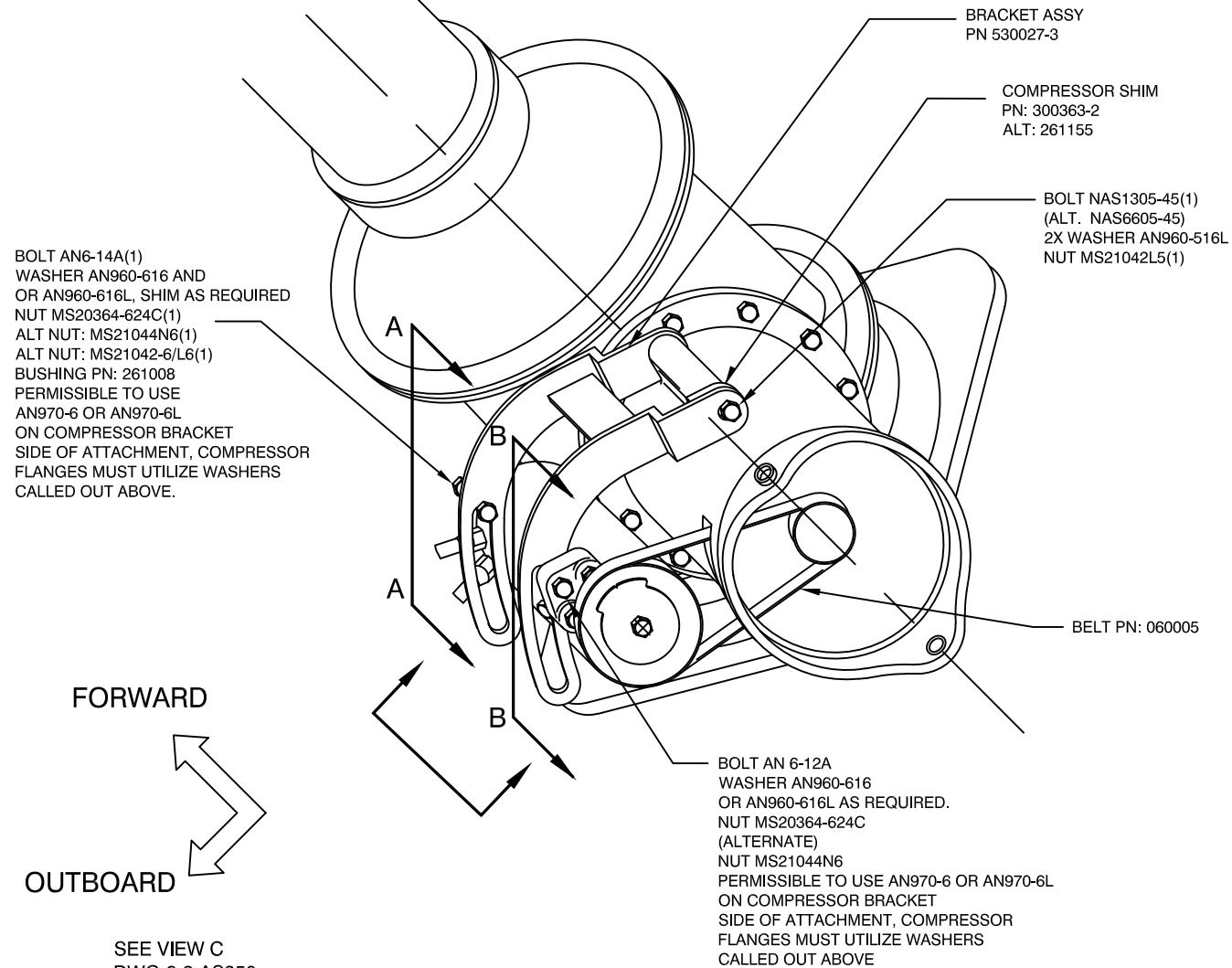

QTY	ITEM	PART NUMBER	DESCRIPTION	Vendor
1	23	NAS1305-45	BOLT (ALT. NAS6605-45)	
2	22	MS20364-624C	NUT (ALT. MS21044N6)	
1	21	MS20364-524C	NUT (ALT. MS21042L5/ OR -5)	
1	20	AN365-624	NUT (ALT. MS21044N6)	
1	19	MS21042L5	NUT	
2	18	AN365-424	NUT (ALT. MS21042L4/ OR -4)	
AR	17	AN960-616	WASHER (ALT. AN960-616L)	
3	16	AN960-516	WASHER (ALT. AN960-516L)	
4	15	AN960-416	WASHER (ALT. AN960-416L)	
1	14	AN6-12A	BOLT	
2	13	AN4-14A	BOLT	
2	12	AN6-14A	BOLT	
1	11	261008	BUSHING	
1	10	060005	BELT	
1	9	300363-2	COMPRESSOR SHIM	
1	8	530027-3	BRACKET ASSEMBLY	
2	7	261007	BUSHING	
1	6	300067-1	COMPRESSOR STAND OFF	
1	5	300363-2	COMPRESSOR SHIM (ALT. 261155)	
1	4	530100-1	STRAP HOUSING	
1	3	300095	COMPRESSOR PIN	
1	2	590008	COMPRESSOR	
--	1	-01	COMPRESSOR INSTALLATION	

UTILIZED WITH:
1. EC 130 B4

PROPRIETARY NOTICE TO ALL PERSONS RECEIVING THIS DOCUMENT THIS DOCUMENT AND INFORMATION OR TECHNICAL DATA AND DESIGNS CONTAINED HEREIN ARE PROPRIETARY DATA AND EXCLUSIVE PROPERTY OF RSG PRODUCTS INC. AND IS DELIVERED ON THE EXPRESS CONDITION THAT NEITHER THIS DOCUMENT NOR THE INFORMATION CONTAINED HEREIN SHALL BE DISCLOSED TO OTHERS, REPRODUCED IN WHOLE OR IN PART, OR USED FOR THE MANUFACTURE OR FABRICATION OF PARTS FOR ANYONE OTHER THAN RSG PRODUCTS INC. WITHOUT WRITTEN CONSENT AND AUTHORIZATION, AND THAT NO RIGHT IS GRANTED TO DISCLOSE OR SO USE ANY INFORMATION CONTAINED IN SAID DOCUMENT. THIS RESTRICTION DOES NOT LIMIT THE RIGHT TO USE INFORMATION OBTAINED FROM ANOTHER SOURCE.	NEXT ASSY. APPROVED BY:	TOLERANCES EXCEPT AS SHOWN .X: ±.1 .XX: ±.03 .XXX: ±.010 X.X": ±.5" BREAK ALL SHARP EDGES .01 ALL DIMENSIONS IN INCHES UNLESS OTHERWISE STATED DATE:	
	TITLE: COMPRESSOR INSTALLATION		

SEE VIEW C
DWG 6-2-AS350

NOTES:

1. INSTALL HARDWARE IAW RSG AERODESIGN DOCUMENT NUMBER 20R00510001.
2. USE ITEM 4 TO TENSION BELT TO F= 30 LBS. DEFLECTION AT CENTER OF THE BELT TO BE .10 INCHES UNDER 5 LB LOAD.
3. TIGHTEN BOTH NUTS AGAINST THE COMP MOUNT TENSION BOLT. SAFETY WIRE NUTS USING ITEM 25 IAW MS33540
4. ENSURE PLANAR TOLERANCE BETWEEN THE TAIL ROTOR AND COMPRESSOR PULLEY CENTERLINE IS $\pm .100$ INCHES. ALIGNMENT CAN BE ADJUSTED BY CHANGING THE WASHER STACKUP BETWEEN ITEM 9 & THE GEAR BOX COUPLING CASE.
5. REAM ITEM 11 BUSHING FOR PROPER FIT OF ITEM 10 PIN USING REAMING TOOL RANGE (.302-N TO .3594-23/64).
6. PERMISSIBLE TO USE ALTERNATE COTTER PIN TYPE HARDWARE: BOLT ANX-XX, NUT AN310-X, COTTER PIN MS24665-XXX.
7. IDENTIFY & MARK ASSEMBLY IAW RSG AERODESIGN DOCUMENT NUMBER 20R00110001. LOCATION, CHARACTER HEIGHT & PROCESS AS REQUIRED. MARK IN CONTRASTING COLOR.

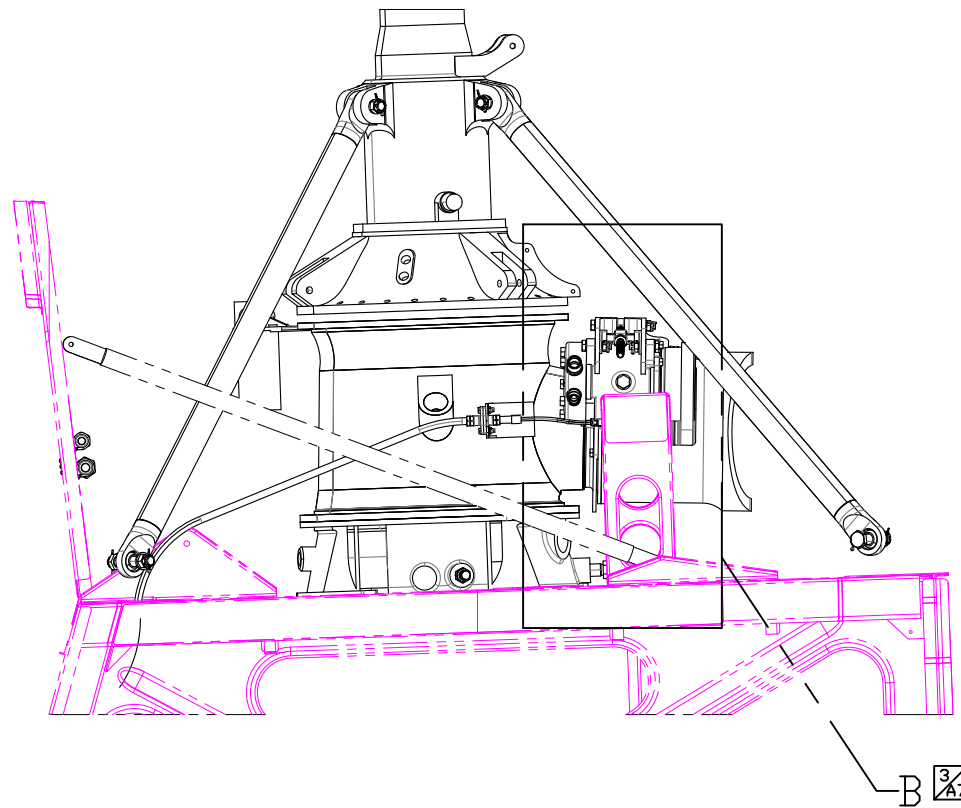
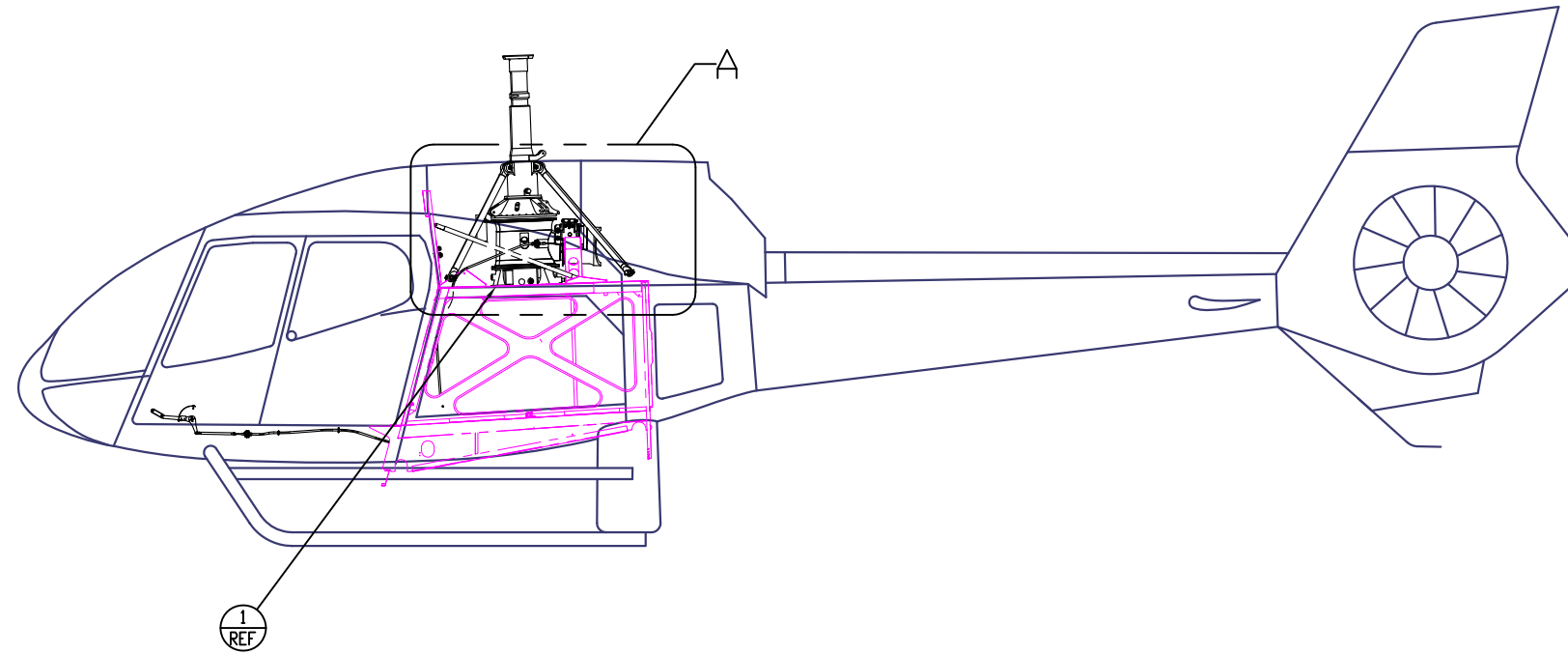

6	26	NAS1149D0632H	WASHER		
2	25	NAS1149D0532H	WASHER		
4	24	MS21042L6	NUT		
2	23	MS21042L5	NUT		
2	22	MS21042L4	NUT		
A/R	21	MS20995C32	SAFETY WIRE		
2	20	AN960-616L	WASHER		
1	19	AN960-516L	WASHER		
4	18	AN960-416	WASHER		
1	17	AN6-33A	BOLT		
1	16	AN6-14A	BOLT		
2	15	AN6-13A	BOLT		
1	14	AN5-34A	BOLT		
2	13	AN4-14A	BOLT		
1	12	590008	COMPRESSOR		12.85 LB
1	11	530100-1	STRAP HOUSING		
1	10	300095	PIN		
1	9	300067-1	COMPRESSOR STAND OFF		
2	8	261007	BUSHING		
1	7	2434K39	THREADED ROD END	McMASTER CARR	
1	6	060018-1	BELT		
2	5	04-130-21-105-01	COMPRESSOR CLAMP		
2	4	04-120-21-104-01	JAM NUT, DRILLED		0.02
1	3	04-130-21-102-01	COMP MOUNT TENSION BOLT		
1	2	04-130-21-101-01	COMPRESSOR MOUNT BRACKET		0.52
--	1	-02	COMPRESSOR INSTALLATION		
QTY	ITEM	PART NUMBER	DESCRIPTION	Vendor	WEIGHT

DETAIL A

(SOME A/C STRUCTURES REMOVED FOR CLARITY)

AFT →

RSG PRODUCTS INC.
A ROTORCRAFT SERVICES GROUP COMPANY

TITLE:
COMPRESSOR INSTALLATION

DRAWN BY: JTYE DATE: 06/15/03 REV.: D SCALE: N/A SHEET: 2 OF 4

APPLICATION: EC 130 B4 DWG. NO.: 6-1-EC130

8 7 6 5 4 3 2 1

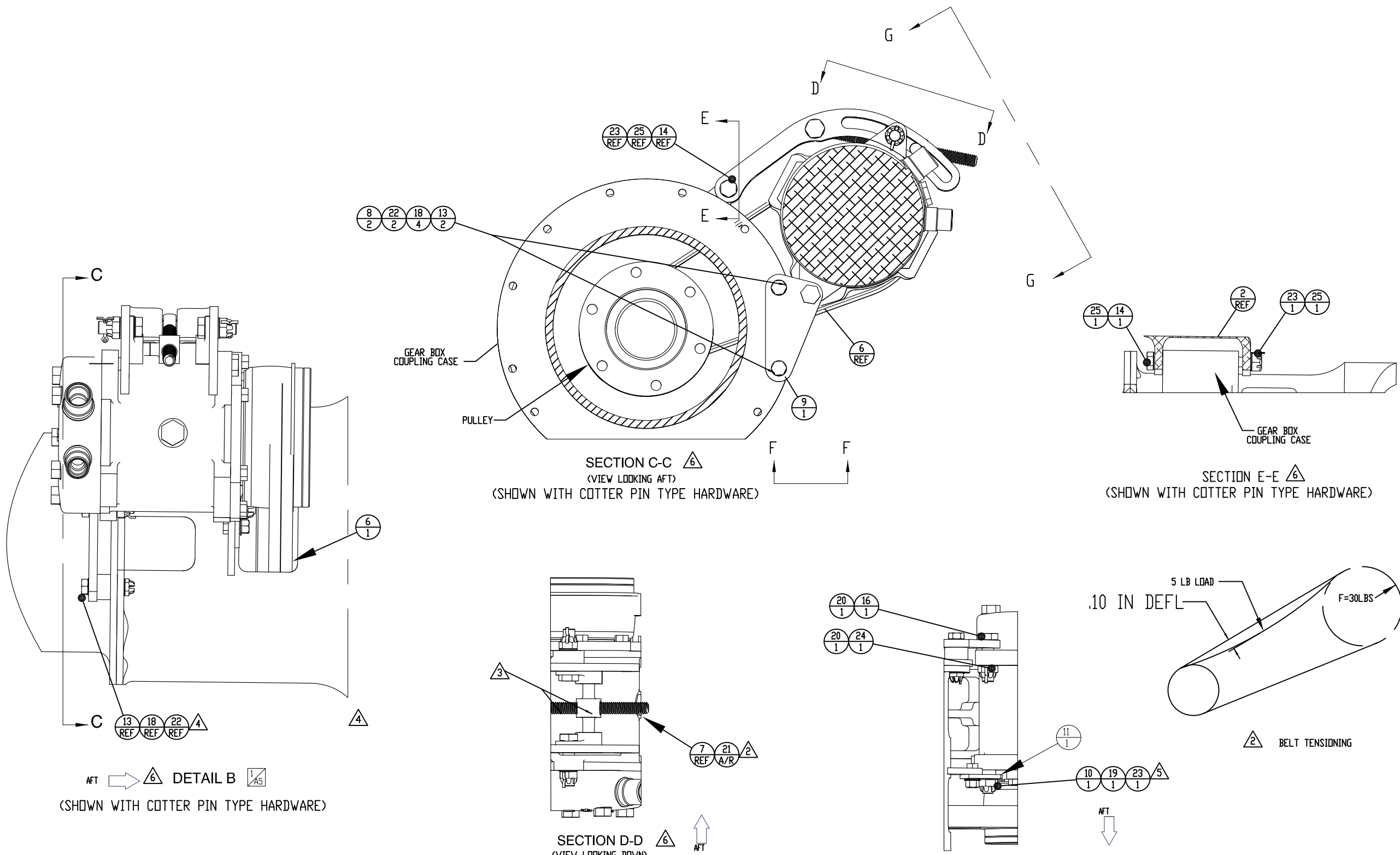

AFT → **DETAIL B** $\frac{1}{A5}$
 (SHOWN WITH COTTER PIN TYPE HARDWARE)

SECTION C-C $\triangle 6$
 (VIEW LOOKING AFT)
 (SHOWN WITH COTTER PIN TYPE HARDWARE)

SECTION E-E $\triangle 6$
 (SHOWN WITH COTTER PIN TYPE HARDWARE)

SECTION D-D $\triangle 6$ ↑ AFT
 (VIEW LOOKING DOWN)
 (SHOWN WITH COTTER PIN TYPE HARDWARE)

SECTION F-F $\triangle 6$ ↓ AFT
 (VIEW LOOKING UP)
 (SHOWN WITH COTTER PIN TYPE HARDWARE)

ASG PRODUCTS INC.
 A ROTORCRAFT SERVICES GROUP COMPANY

TITLE:
COMPRESSOR INSTALLATION

DRAWN BY: JTYE	DATE: 06/15/03	REV.: D	SCALE: N/A	SHEET: 3 OF 4
-------------------	-------------------	------------	---------------	------------------

APPLICATION: EC 130 B4	DWG. NO.: 6-1-EC130
---------------------------	------------------------

8 7 6 5 4 3 2 1

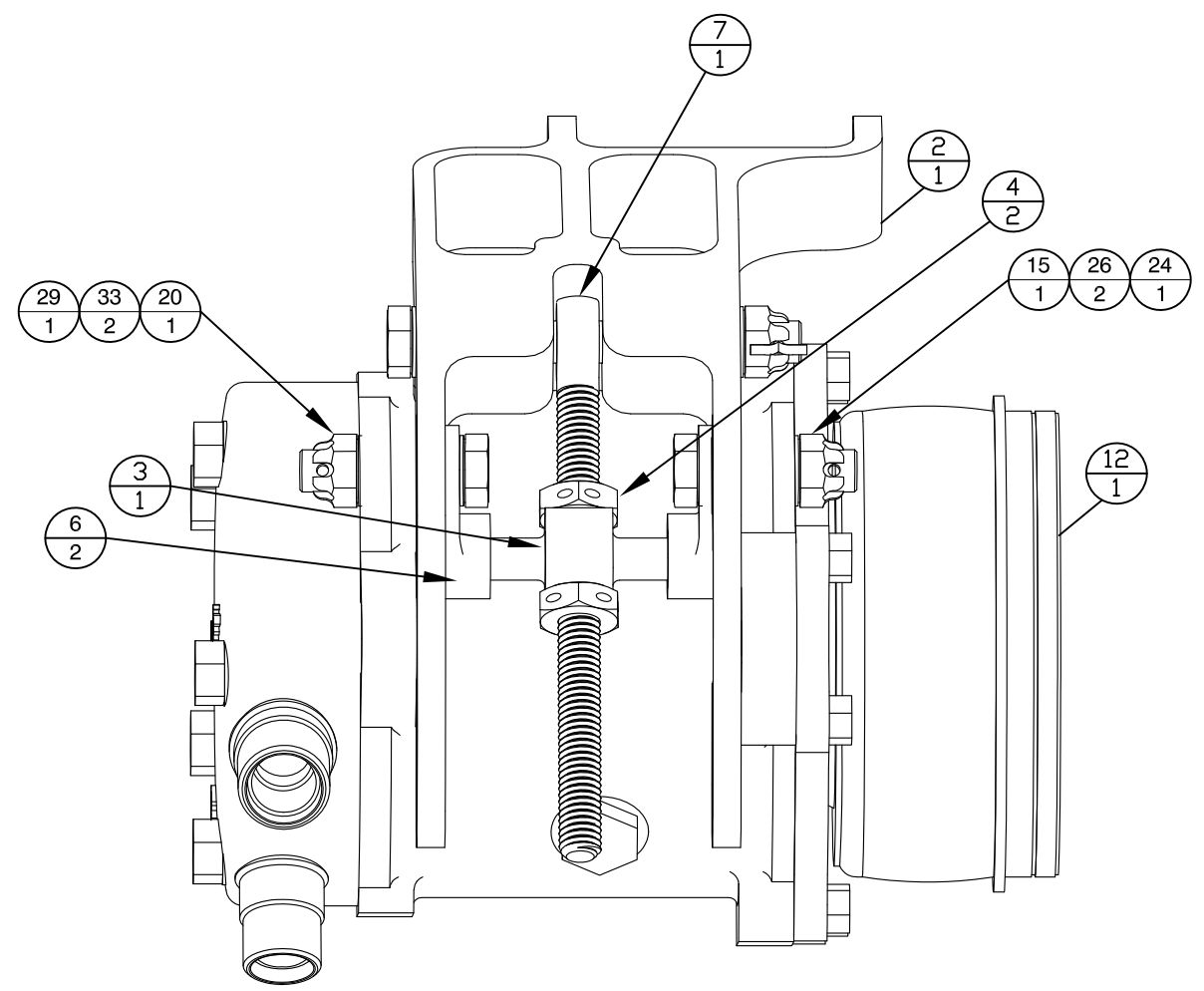

VIEW G-G

VIEW G-G $\triangle 6$
 (SHOWN WITH COTTER PIN TYPE HARDWARE)

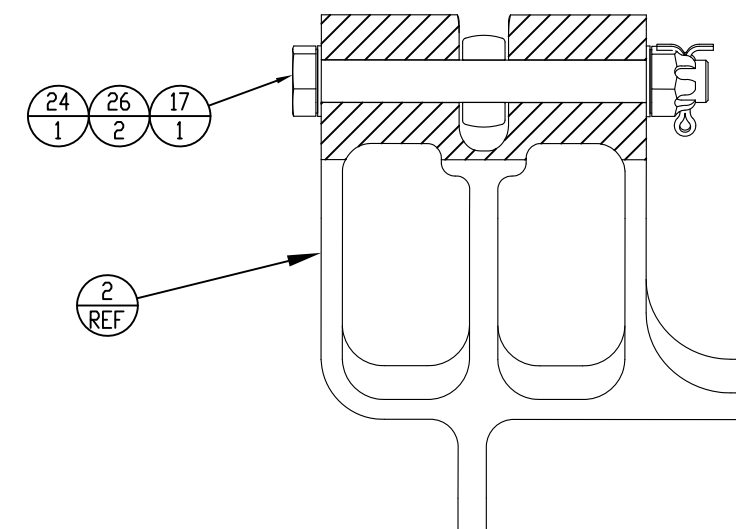

SECTION H-H $\triangle 6$
 (SHOWN WITH COTTER PIN TYPE HARDWARE)



TITLE: COMPRESSOR INSTALLATION				
DRAWN BY: JT YE	DATE: 06/15/03	REV.: D	SCALE: N/A	SHEET: 4 OF 4
APPLICATION: EC 130 B4			DWG. NO.: 6-1-EC130	

REVISION RECORD				
REV	DATE	DESCRIPTION OF CHANGE	APPVD. BY	REV. BY
A	01/30/06	REVISED TITLE BLOCK. REMOVED BEVELED EDGE NOTATION. ADDED SHIM NOTES. REMOVED ADDITIONAL PN:261007 AT WRONG LOCATION. PER ECO # 106. REVISED PN's FOR ACCURACY.		JTYE
B	09/01/14	CHANGED TITLE BLOCK AND REVISION BLOCK. REVISED PART NUMBERS UNDER CALL OUTS PER ECO #'s 0262 & 0375.		AJC

NOTE:
DO NOT CUT TRANSMISSION
FLANGE-NOT REQUIRED

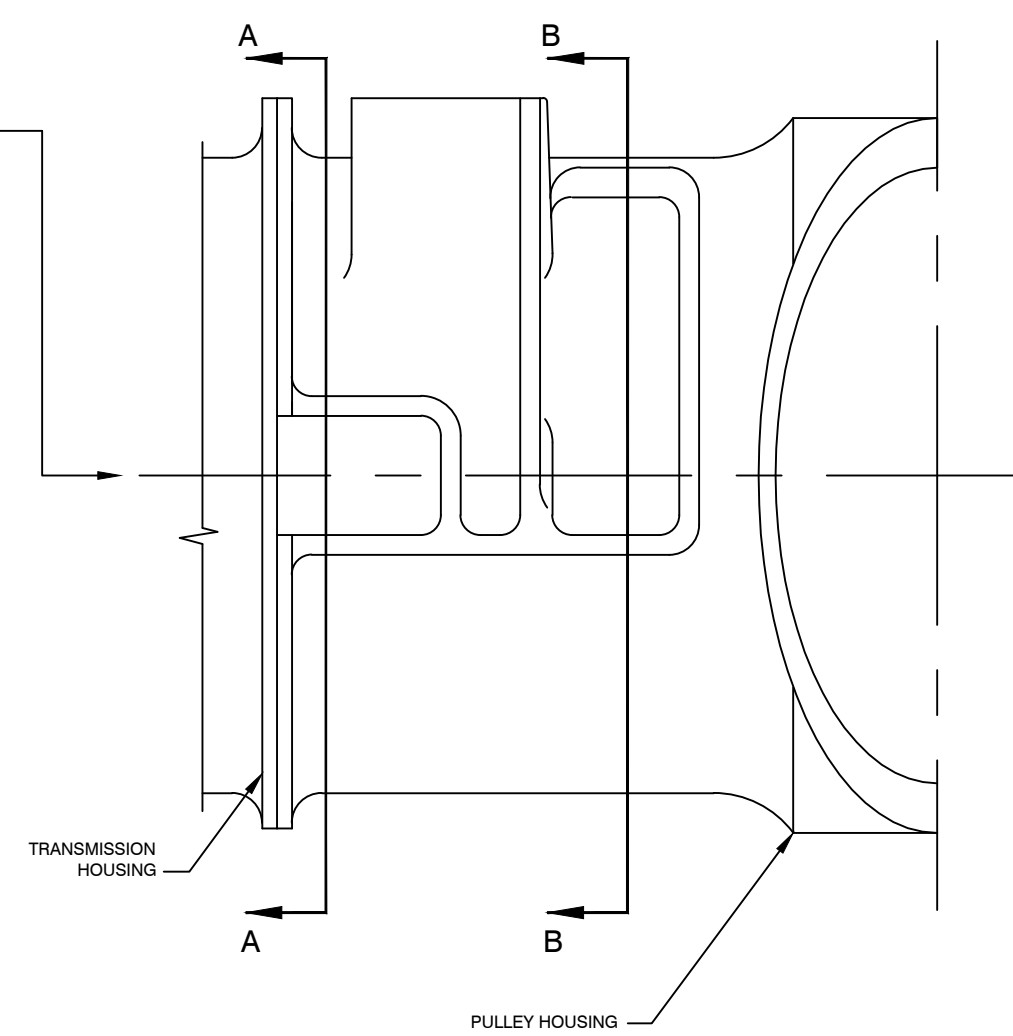
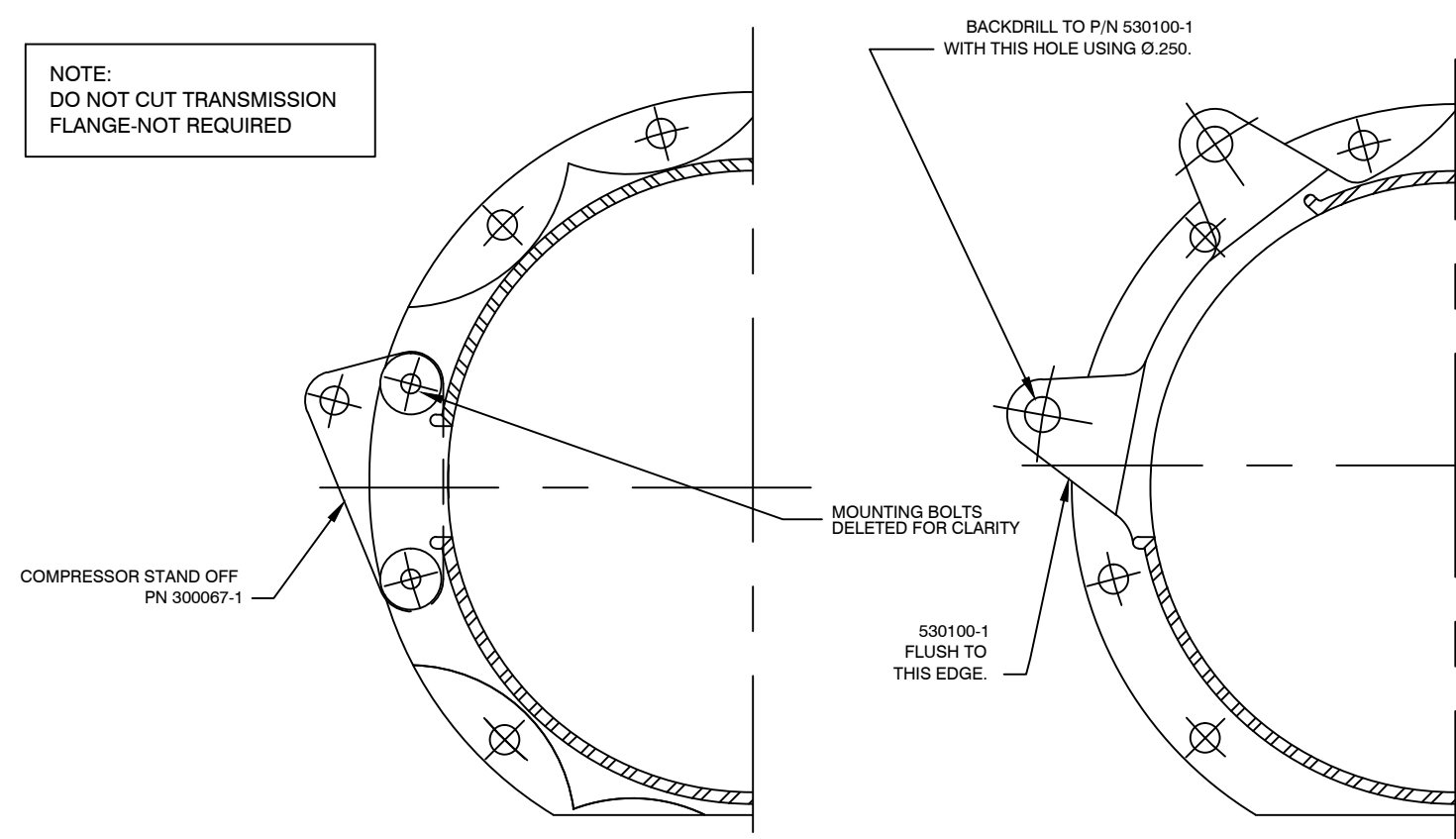

NOTE:
SHIM IF REQUIRED TO AVOID
PRE-LOADING OF BRACKET
FORKS.

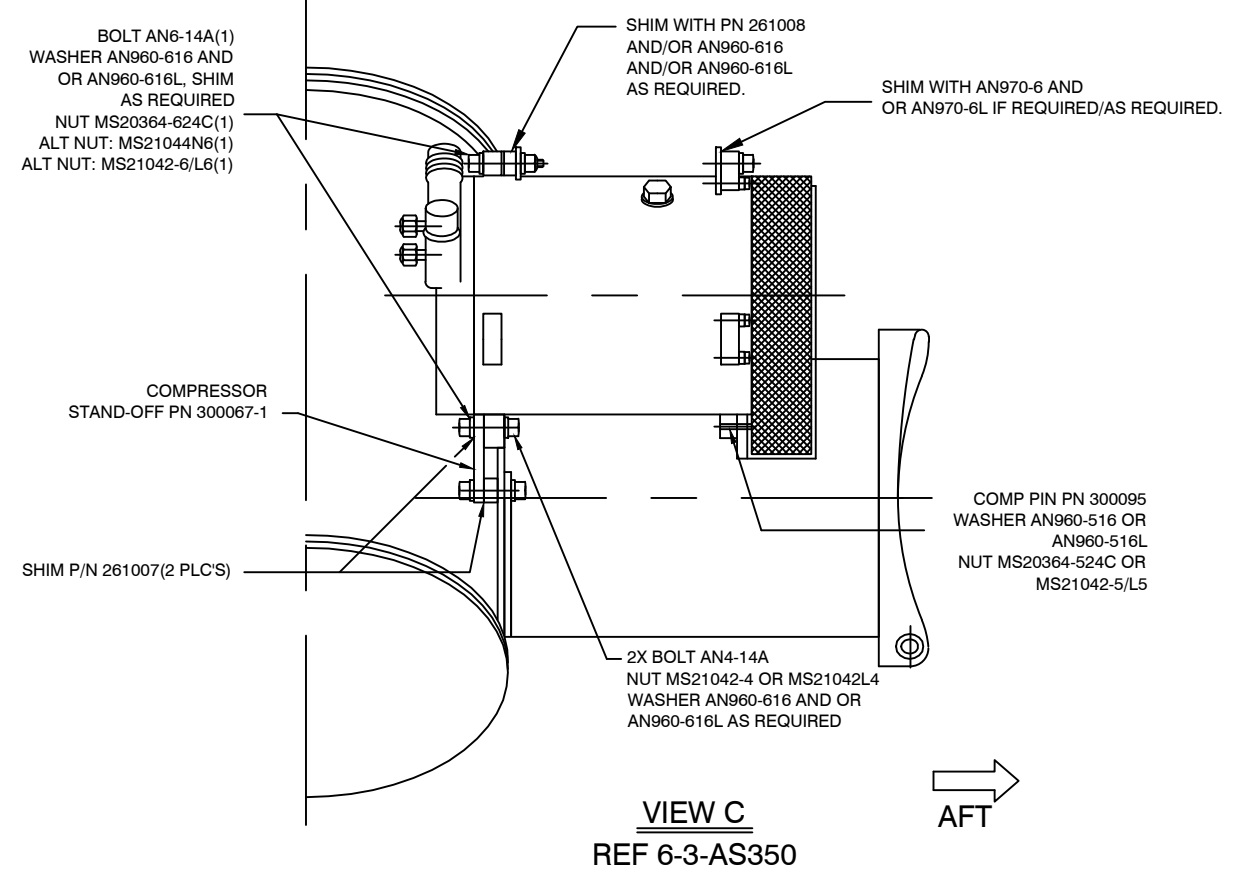

UTILIZED WITH:
1. EC 130 B4.

PROPRIETARY NOTICE <small>TO ALL PERSONS RECEIVING THIS DOCUMENT THIS DOCUMENT AND INFORMATION OR TECHNICAL DATA AND DESIGNS CONTAINED HEREIN ARE PROPRIETARY DATA AND EXCLUSIVE PROPERTY OF RSG PRODUCTS INC. AND IS DELIVERED ON THE EXPRESS CONDITION THAT NEITHER THIS DOCUMENT NOR THE INFORMATION CONTAINED HEREIN SHALL BE DISCLOSED TO OTHERS, REPRODUCED IN WHOLE OR IN PART, OR USED FOR THE MANUFACTURE OR FABRICATION OF PARTS FOR ANYONE OTHER THAN RSG PRODUCTS INC. WITHOUT WRITTEN CONSENT AND AUTHORIZATION, AND THAT NO RIGHT IS GRANTED TO DISCLOSE OR SO USE ANY INFORMATION CONTAINED IN SAID DOCUMENT. THIS RESTRICTION DOES NOT LIMIT THE RIGHT TO USE INFORMATION OBTAINED FROM ANOTHER SOURCE.</small>	NEXT ASSY.	TOLERANCES EXCEPT AS SHOWN						
			.X: ±.1 .XX: ±.03 .XXX: ±.010 X.X°: ±.5° BREAK ALL SHARP EDGES .01 ALL DIMENSIONS IN INCHES UNLESS OTHERWISE STATED	TITLE: COMPRESSOR INSTALLATION				
	APPROVED BY:		DATE:	DRAWN BY: JTYE	DATE: 06/15/03	REV.: B	SCALE: N/A	SHEET: 1 OF 1
				APPLICATION: EC 130 B4			DWG. NO.: 6-2-EC130	

REVISION RECORD				
REV	DATE	DESCRIPTION OF CHANGE	APPVD. BY	REV. BY
A	01/30/06	CHANGED NAS1305-44 BOLT TO -45, FOR LENGTH. ADDED ALTERNATE COMPRESSOR SHIM PN: 261155. REMOVED BEVELED EDGE NOTATIONS. REVISED TITLE BLOCK.		JTYE
B	09/01/14	CHANGED TITLE BLOCK AND REVISION BLOCK.		AJC

NOTE:
COMPRESSOR REMOVED FOR CLARITY

P/N 300363-2 IS LOCATED BETWEEN GIMBLE HOUSING & P/N 530027-3
ALT: P/N 261155

BACKDRILL Ø.250 HOLE INTO 530100-1 ONCE LOCATED AND INSTALL HARDWARE:
AN4-5A BOLT (1)
AN960-416L WASHER (2)
MS21042-L4 NUT (1)

ALIGN 530100-1 ON AFT SIDE OF GIMBLE HOUSING, FLUSH EDGE TO EAR CONTOUR.

SECTION A-A

FLUSH THIS EDGE TO EAR.

**DETAIL A
NOT TO SCALE**

BACKDRILL Ø.250 HOLE.

UTILIZED WITH:
1. EC 130 B4.

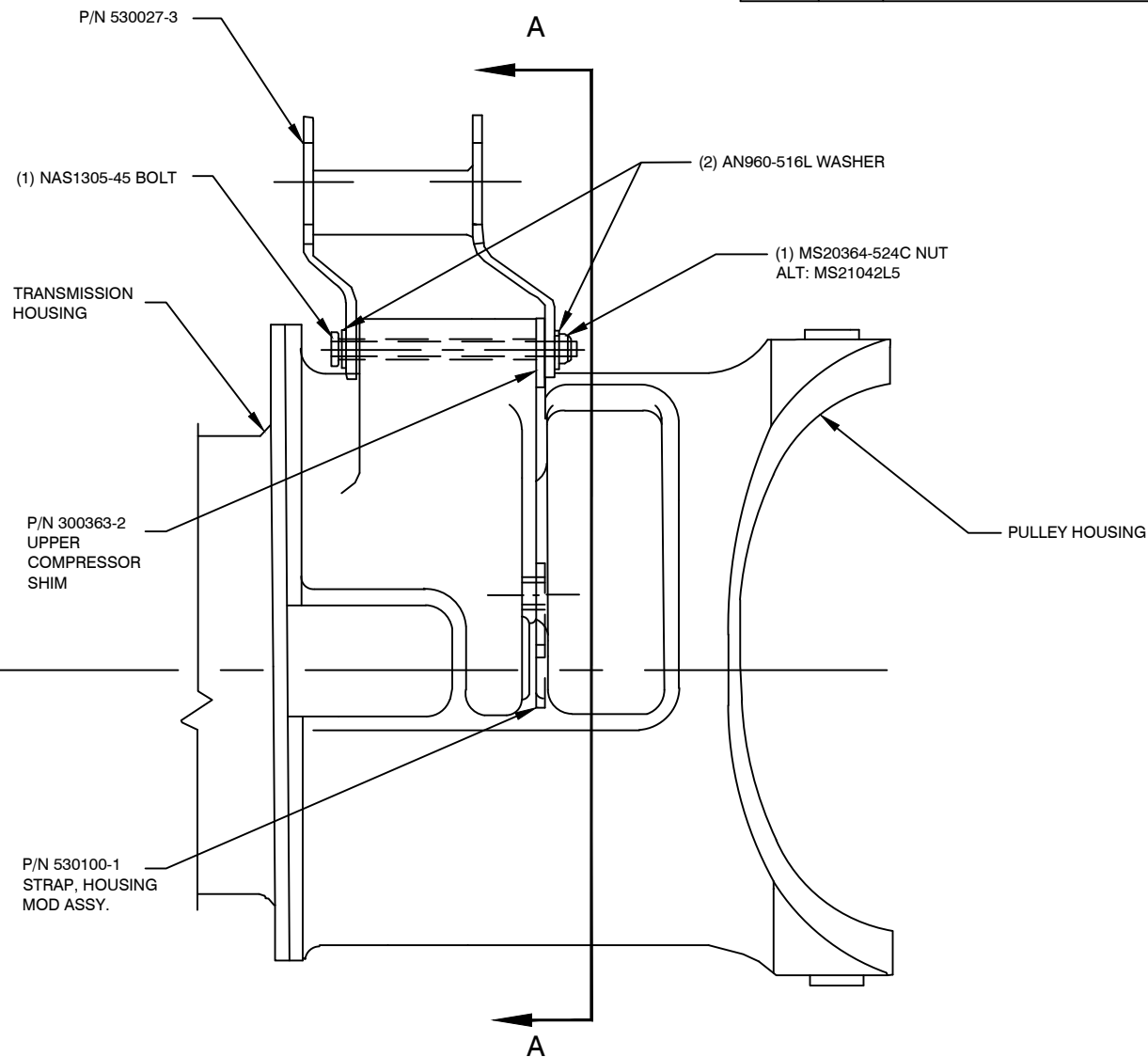

VIEW LOOKING INBOARD
← FORWARD →

PROPRIETARY NOTICE TO ALL PERSONS RECEIVING THIS DOCUMENT THIS DOCUMENT AND INFORMATION OR TECHNICAL DATA AND DESIGNS CONTAINED HEREIN ARE PROPRIETARY DATA AND EXCLUSIVE PROPERTY OF RSG PRODUCTS INC. AND IS DELIVERED ON THE EXPRESS CONDITION THAT NEITHER THIS DOCUMENT NOR THE INFORMATION CONTAINED HEREIN SHALL BE DISCLOSED TO OTHERS, REPRODUCED IN WHOLE OR IN PART, OR USED FOR THE MANUFACTURE OR FABRICATION OF PARTS FOR ANYONE OTHER THAN RSG PRODUCTS INC. WITHOUT WRITTEN CONSENT AND AUTHORIZATION, AND THAT NO RIGHT IS GRANTED TO DISCLOSE OR SO USE ANY INFORMATION CONTAINED IN SAID DOCUMENT. THIS RESTRICTION DOES NOT LIMIT THE RIGHT TO USE INFORMATION OBTAINED FROM ANOTHER SOURCE.	NEXT ASSY.	TOLERANCES EXCEPT AS SHOWN		
		.X: ±.1 .XX: ±.03 .XXX: ±.010 X.X°: ±.5° BREAK ALL SHARP EDGES .01 ALL DIMENSIONS IN INCHES UNLESS OTHERWISE STATED		TITLE: COMPRESSOR INSTALLATION
	APPROVED BY:		DATE:	DRAWN BY: JTYE DATE: 06/15/03 REV.: B SCALE: N/A SHEET: 1 OF 1
				APPLICATION: EC 130 B4 DWG. NO.: 6-3-EC130

REVISION RECORD				
REV	DATE:	DESCRIPTION OF CHANGE	APPVD. BY	REV. BY
A	08/25/09	REVISED TITLE BLOCK.		DWE
B	09/01/14	CHANGE TITLE BLOCK AND REVISION BLOCK.		AJC

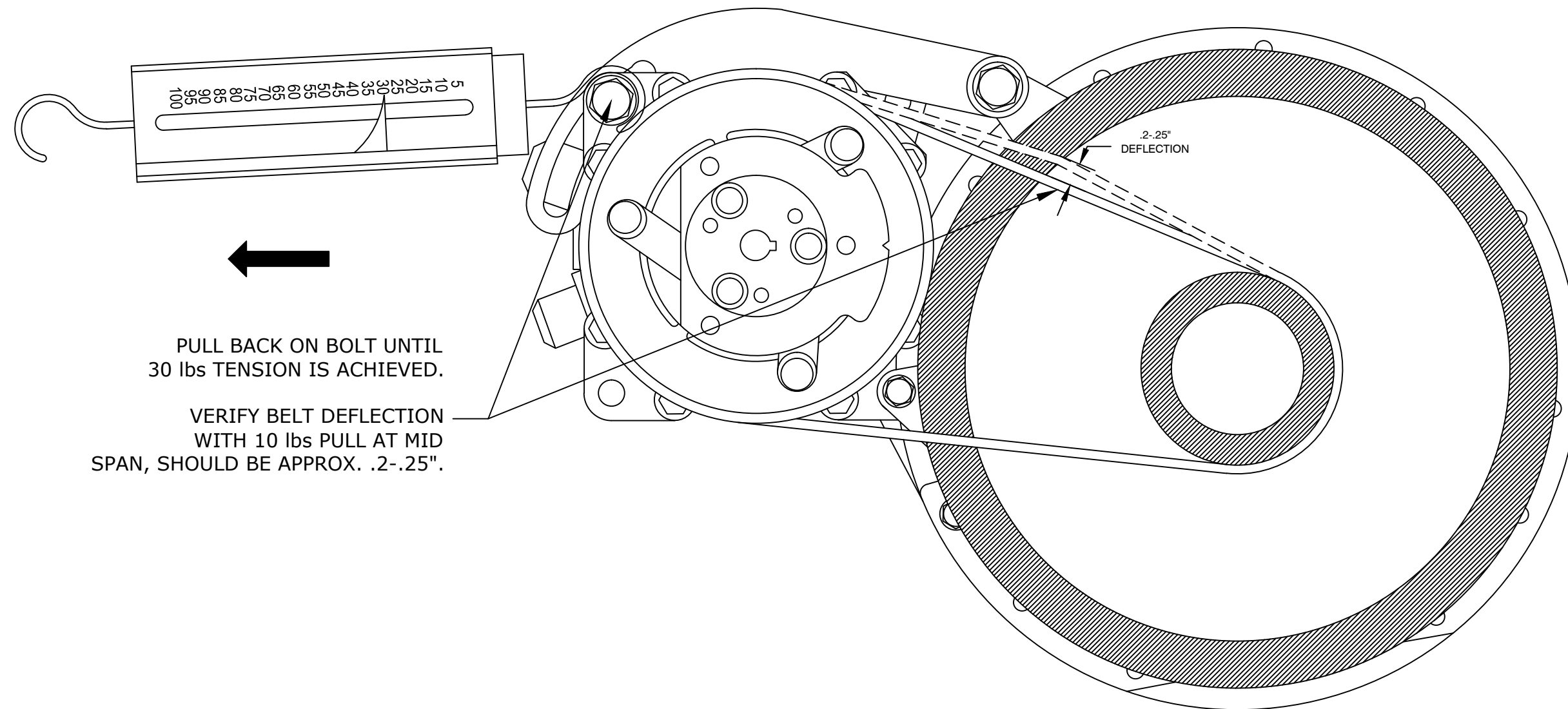

PROPRIETARY NOTICE TO ALL PERSONS RECEIVING THIS DOCUMENT THIS DOCUMENT AND INFORMATION OR TECHNICAL DATA AND DESIGNS CONTAINED HEREIN ARE PROPRIETARY DATA AND EXCLUSIVE PROPERTY OF RSG PRODUCTS INC. AND IS DELIVERED ON THE EXPRESS CONDITION THAT NEITHER THIS DOCUMENT NOR THE INFORMATION CONTAINED HEREIN SHALL BE DISCLOSED TO OTHERS, REPRODUCED IN WHOLE OR IN PART, OR USED FOR THE MANUFACTURE OR FABRICATION OF PARTS FOR ANYONE OTHER THAN RSG PRODUCTS INC. WITHOUT WRITTEN CONSENT AND AUTHORIZATION, AND THAT NO RIGHT IS GRANTED TO DISCLOSE OR SO USE ANY INFORMATION CONTAINED IN SAID DOCUMENT. THIS RESTRICTION DOES NOT LIMIT THE RIGHT TO USE INFORMATION OBTAINED FROM ANOTHER SOURCE.	NEXT ASSY.	TOLERANCES EXCEPT AS SHOWN		
		.X: ±.1 .XX: ±.03 .XXX: ±.010 X.X": ±.5° BREAK ALL SHARP EDGES .01 ALL DIMENSIONS IN INCHES UNLESS OTHERWISE STATED		TITLE: BELT TENSION
	APPROVED BY:	DATE:		DRAWN BY: JTYE DATE: 06/15/03 REV.: B SCALE: N/A SHEET: 1 OF 1 APPLICATION: EC 130 B4 DWG. NO.: 6-5-EC130

INSTALLATION INSTRUCTIONS:

KIT P/N: 350-00-011HP OR -031HP
(HIGH PERFORMANCE)

- 1) THE ABOVE TWO (2) KITS UTILIZE THE SANDEN SD-507 COMPRESSOR IFS PN: 590008 OR COMPRESSOR PN: 590008-1 IN LIEU OF THE SANDEN SD-505 IFS P/N: 590001-1-0. AN INCREASE OF 2 CUBIC INCHES IN DISPLACEMENT IS ACHIEVED. BOTH UNITS HAVE THE SAME "FOOT PRINT". HOWEVER, THE SD-507 IS SLIGHTLY LONGER.
- 2) THE SAME BELT P/N's: 060018 OR 060018-1 ARE UTILIZED IN THIS INSTALLATION WITH COMPRESSOR PN: 590008. BELT P/N's: 060005 WILL BE UTILIZED WITH COMPRESSOR PN: 590008-1.
- 3) THE SAME COMPRESSOR MOUNT ASSEMBLY P/N: 530027-3, PIN P/N: 300095, AND COMPRESSOR STAND OFF P/N: 300067 ARE UTILIZED IN THIS INSTALLATIONS.
- 4) THE AFT, INBOARD COMPRESSOR MOUNTING POINT IS RELOCATED FORWARD BY PLACING TWO ALUMINUM "BUSHINGS", P/N: 261007 BETWEEN THE "STAND OFF" P/N: 300067 AND THE TRANSMISSION HOUSING. TWO (2) EACH AN4-15A BOLTS MUST BE UTILIZED IN LIEU OF THE AN4-11A FORMERLY USED.
- 6) THE FORWARD, UPPER INBOARD COMPRESSOR EAR IS ALIGNED WITH THE COMPRESSOR UNIT ASSEMBLY BY PLACING A "BUSHING", P/N 261008 BETWEEN THE AFT SIDE OF THE EAR AND THE MOUNT ASSEMBLY.
- 7) AN6-12A BOLTS ARE USED TO ENSURE BELT TENSION IN THE SAME MANNER AS WITH THE SD-505 COMPRESSOR. A MINIMUM THREAD PROTRUSION ON THE FORWARD UPPER BOLT REQUIRES THAT A STEEL SELF LOCKING NUT P/N: MS20364-624C MUST BE UTILIZED.

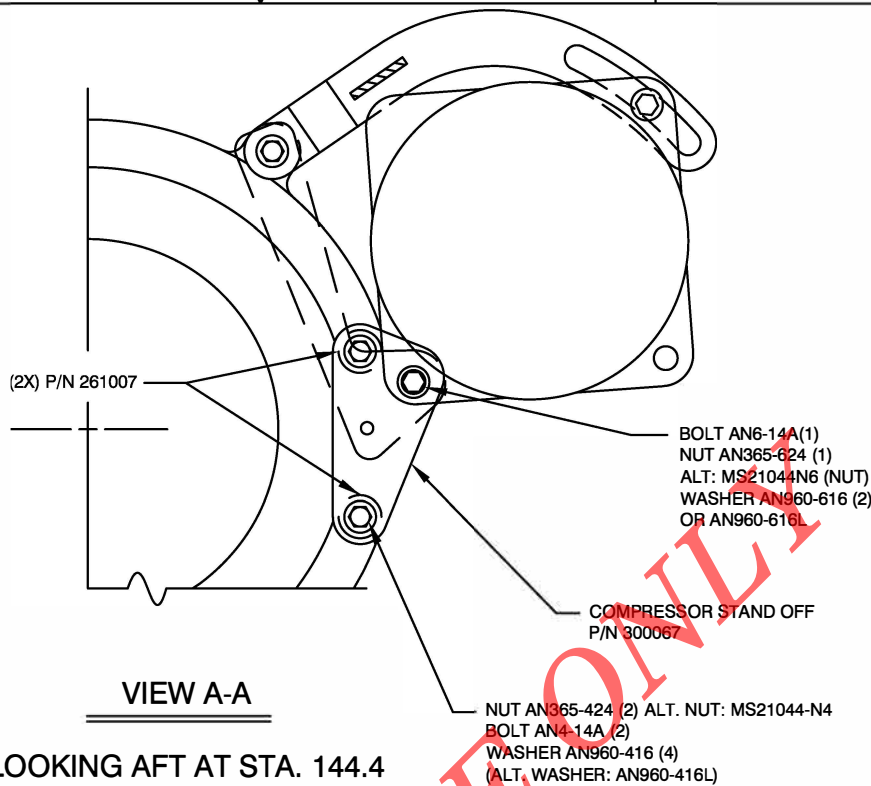

VIEW A-A
LOOKING AFT AT STA. 144.4

REVISION RECORD				
REV	DATE	DESCRIPTION OF CHANGE	APPVD. BY	REV. BY
A	08-16-00	REVISED DRAWING NUMBER, WAS 6-AS350 SHEET NUMBER WAS 1 OF 3.		
B	04/15/02	COMPUTERIZED, CHANGED TITLE BLOCK TO PAG. ADDED VIEW OF P/N 530100. CHANGED 530027-1 TO 530027-3.		
C	07/15/02	CHANGED PN: 261008 TO 2X PN: 261007, REVISED TITLE BLOCK.		
D	01/30/06	CHANGED BOLT, NAS1305-44 TO NAS1305-45 FOR EXTRA LENGTH. ADDED BELT PN 060018-1 TO ADDRESS LENGTH ISSUE. CHANGED NO. OF WASHERS ADDED "AS REQUIRED" TO WASHER NOTATION. ADDED COMPRESSOR PN: 590008-1 ADDED BELTS PN's 060005 AND 060006 FOR ALT. COMPRESSOR INSTALLATION. ADDED NOTATION TO CHANGE PULLEY ON TAIL ROTOR DRIVE SHAFT. REVISED APPLICABLE NOTATION.		JTYE
E	06/30/08	AEC PN: 350A351094 IS NOW PN: 350A35-1094-20. CORRECTED TO MATCH AEC IPC. REMOVED BELT PN: 060006, CORRECTED NOTE 2 TO MATCH. REVISED TITLE BLOCK.		JTYE
F	09/01/14	CHANGED TITLE BLOCK AND REVISION BLOCK.		AJC
G	01/19/22	ADDED ALTERNATE BOLT NAS6605-45 PER ECO 0941.		SGB

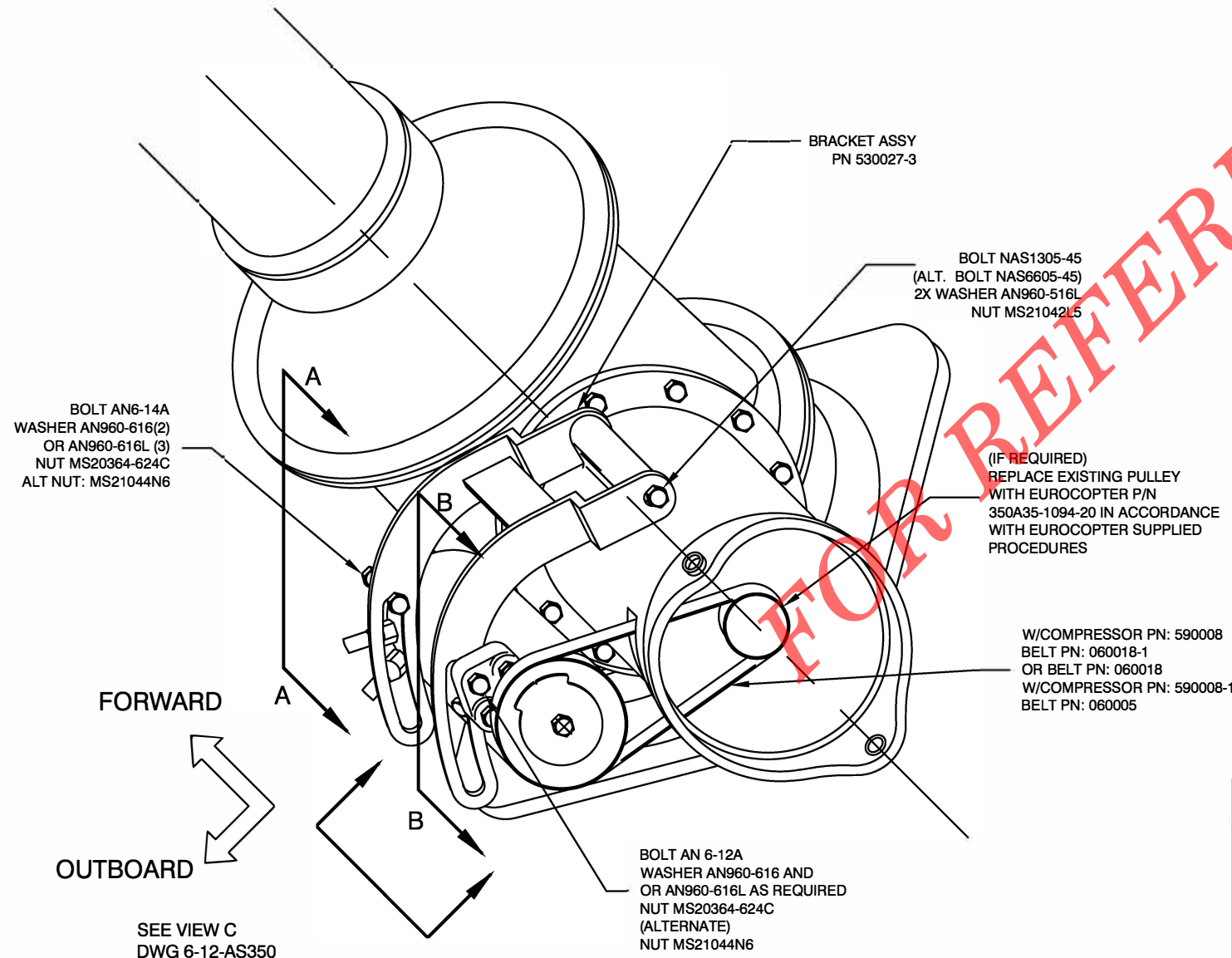

- UTILIZED WITH:
1. AS 350 WITH OLDER TRANSMISSION HOUSING DESIGN.

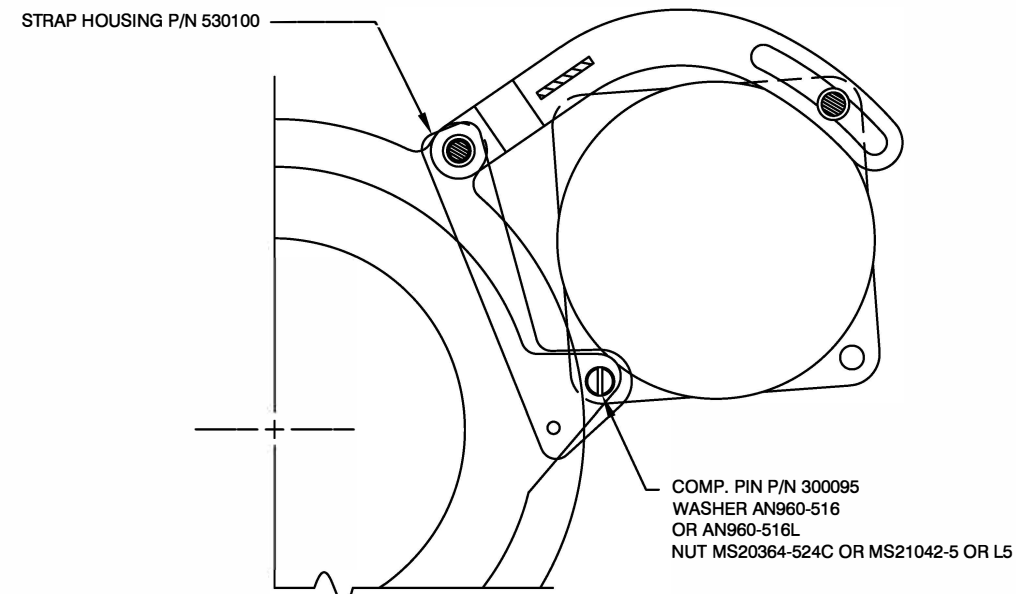

VIEW B-B
LOOKING AFT AT STA. 151.2

<p>PROPRIETARY NOTICE</p> <p>TO ALL PERSONS RECEIVING THIS DOCUMENT THIS DOCUMENT AND INFORMATION OR TECHNICAL DATA AND DESIGNS CONTAINED HEREIN ARE PROPRIETARY DATA AND EXCLUSIVE PROPERTY OF RSG PRODUCTS INC. AND IS DELIVERED ON THE EXPRESS CONDITION THAT NEITHER THIS DOCUMENT NOR THE INFORMATION CONTAINED HEREIN SHALL BE DISCLOSED TO OTHERS, REPRODUCED IN WHOLE OR IN PART, OR USED FOR THE MANUFACTURE OR FABRICATION OF PARTS FOR ANYONE OTHER THAN RSG PRODUCTS INC. WITHOUT WRITTEN CONSENT AND AUTHORIZATION, AND THAT NO RIGHT IS GRANTED TO DISCLOSE OR SO USE ANY INFORMATION CONTAINED IN SAID DOCUMENT. THIS RESTRICTION DOES NOT LIMIT THE RIGHT TO USE INFORMATION OBTAINED FROM ANOTHER SOURCE.</p>	<p>NEXT ASSY.</p>	<p>TOLERANCES EXCEPT AS SHOWN</p> <p>.X: ±.1 .XX: ±.03 .XXX: ±.010 X.X": ±.5" BREAK ALL SHARP EDGES .01 ALL DIMENSIONS IN INCHES UNLESS OTHERWISE STATED</p>	<p>RSG PRODUCTS INC. A ROTORCRAFT SERVICES GROUP COMPANY</p>		
	<p>APPROVED BY:</p>	<p>DATE:</p>		<p>TITLE: COMPRESSOR INSTALLATION</p>	
<p>DRAWN BY: BRP</p>		<p>DATE: 11/10/96</p>	<p>REV.: G</p>	<p>SCALE: N/A</p>	<p>SHEET: 1 OF 1</p>
<p>APPLICATION: AS350</p>		<p>DWG. NO.: 6-2-AS350</p>			

NOTES:

- UTILIZED ON AS350 WITH LATEST TRANSMISSION HOUSING DESIGN
- ALTERNATE FOR ITEM 16 COMPRESSOR IS P/N 590008 WHICH CAN ONLY BE USED WITH ITEM 7 ALTERNATE BELT P/N 060018-1.
- ENSURE PLANAR TOLERANCE BETWEEN THE TAIL ROTOR & COMPRESSOR PULLEY CENTERLINE IS ±.100 IN. ALIGNMENT CAN BE ADJUSTED BY CHANGING THE WASHER STACKUP BETWEEN ITEM 11 & GEAR BOX COUPLING CASE.
- REAM ITEM 10 BUSHING FOR PROPER FIT OF ITEM 12 PIN WITH RANGE .302 TO .359 IN.
- TENSION BELT TO F= 30 LBS. DEFLECTION AT CENTER OF THE BELT TO BE .10 IN. UNDER 5 LB LOAD.
- REPLACE EXISTING RING TERMINAL WITH ITEM 39 FOR USE WITH 1/4" HARDWARE ON BRACKET ASSEMBLY TO MOUNT GROUNDING STRAP ON ITEM 14. SEAL TERMINAL RING AND FASTENER WITH ITEM 38.
- COMPRESSOR BRACKET KIT P/N: 350-11-031-02. (SEE TABLE 1)

TABLE 1
COMPRESSOR BRACKET KIT P/N: 350-11-031-02

ITEM DESCRIPTION	PART NUMBER	QTY
COMPRESSOR MOUNT BRACKET	04-130-21-101-01	1
COMPRESSOR MOUNT TENSION BOLT	04-130-21-102-01	1
JAM NUT, DRILLED	04-130-21-104-01	2
COMPRESSOR CLAMP	04-130-21-105-01	2
BUSHING, SD 507	261007	2
COMPRESSOR STANDOFF	300067-1	1
UPPER COMPRESSOR SHIM	300363-2	2
COMPRESSOR PIN	300095	1
STRAP, HOUSING MOD ASSEMBLY	530100-1	1

REVISION RECORD				
REV	DATE	DESCRIPTION OF CHANGE	APPVD. BY	REV. BY
D	09/01/14	CHANGED TITLE BLOCK AND REVISION BLOCK. ADDED AND CHANGED PART NUMBERS, DESCRIPTION AND QUANTITIES TO BOM PER ECO # 0568.		AJC
E	01/19/22	INCORPORATED ECO'S 0720, 0908, 0941 & 0982.		SGB
F	08/04/23	INCORPORATED ECO'S 1180 AND 1188.		SGB

SEE ECO 1290
SEE ECO 1300

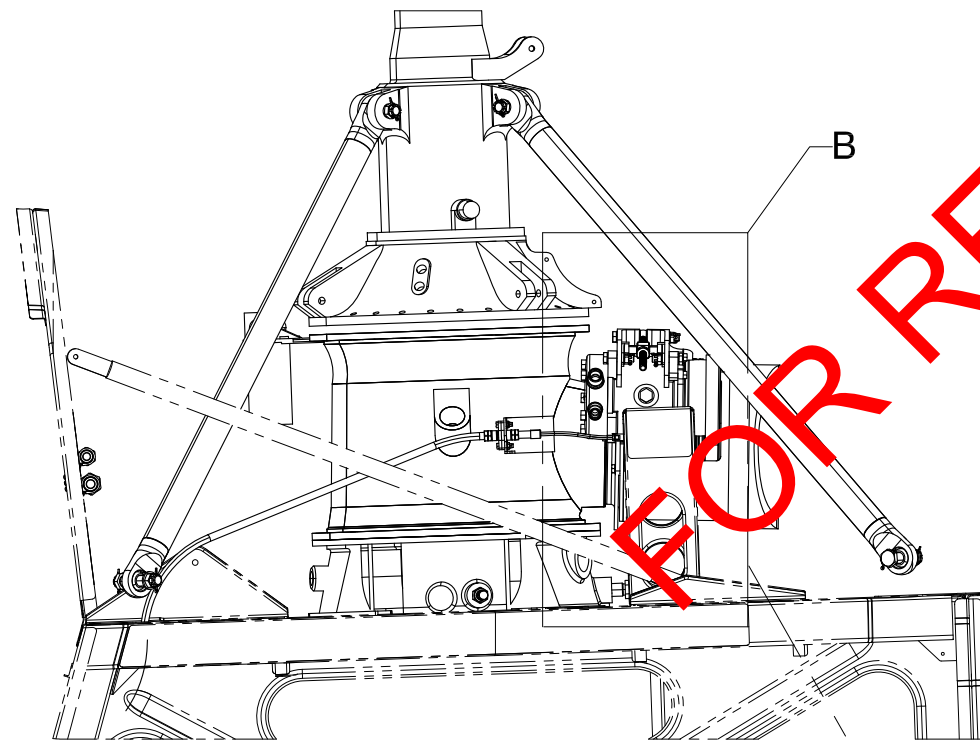
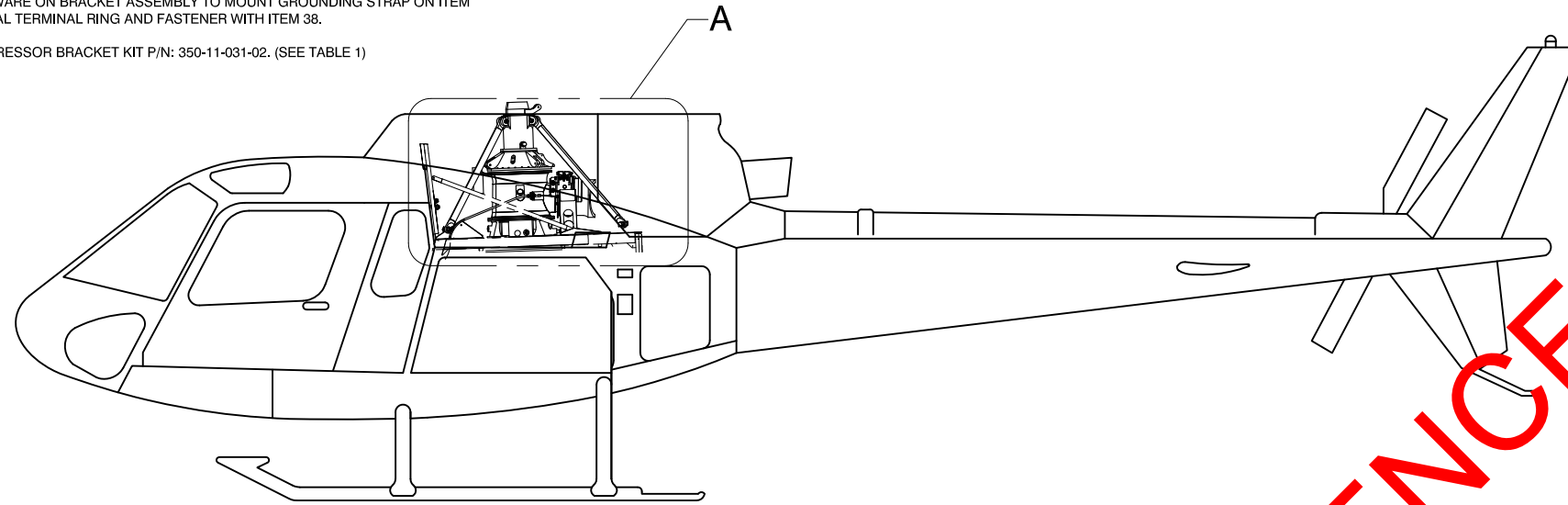

DETAIL A
(SOME A/C STRUCTURES REMOVED FOR CLARITY)
AFT →

1 OR 2
REF OR REF

FOR REFERENCE ONLY

QTY	QTY	ITEM	PART NUMBER	DESCRIPTION	VENDOR	WEIGHT
		39	MS25036-150	RING TERMINAL		
A/R	A/R	38	PR 1440 B 1/2	SEALANT		
		37	NAS1149DO416H	WASHER		
1	1	36	MS21042L4	NUT		
1	1	35	AN4-5A	BOLT		
1	1	34	NAS1305-45	BOLT (ALT. NAS6605-45)		
6		33	NAS1149D0632H	WASHER		
2		32	NAS1149D0532H	WASHER		
	2	31	MS20364-624C	NUT (ALT. MS21044N6)		
	1	30	AN365-624	NUT (ALT. MS21044N6)		
4		29	MS21042L6	NUT		
2	2	28	MS21042L5	NUT (ALT. MS20364-524C)		
2	2	27	MS21042L4	NUT (ALT. AN365-424)		
A/R		26	MS20995C32	SAFETY WIRE		
2	A/R	25	AN960-616L	WASHER (ALT. AN960-616)		
1	3	24	AN960-516L	WASHER (ALT. AN960-516)		
4	4	23	AN960-416	WASHER (ALT. AN960-416L)		
1		22	AN6-33A	BOLT		
1	2	21	AN6-12	BOLT		
2		20	AN6-13A	BOLT		
	1	19	AN6-12A	BOLT		
1		18	AN5-34A	BOLT		
2	2	17	AN4-14A	BOLT		
1	1	16	590008-1	COMPRESSOR		12.85 LB
1	1	15	530100-1	STRAP HOUSING		
	1	14	530027-3	BRACKET ASSEMBLY		
1	1	13	300363-2	SHIM (ALT: 261155)		
1	1	12	300095	PIN		
1	1	11	300067-1	COMPRESSOR STAND OFF		
	1	10	261008	BUSHING		
2	2	9	261007	BUSHING		
1		8	2434K39	THREADED ROD END	McMASTER CARR	
1	1	7	060005	BELT		
2		6	04-130-21-105-01	COMPRESSOR CLAMP		
2		5	04-130-21-104-01	JAM NUT, DRILLED		
1		4	04-130-21-102-01	COMP MOUNT TENSION BOLT		
1		3	04-130-21-101-01	COMPRESSOR MOUNT BRACKET		0.52 LB
--		2	-02	COMPRESSOR INSTALLATION		
--		1	-01	COMPRESSOR INSTALLATION		

<p>PROPRIETARY NOTICE</p> <p>TO ALL PERSONS RECEIVING THIS DOCUMENT THIS DOCUMENT AND INFORMATION OR TECHNICAL DATA AND DESIGNS CONTAINED HEREIN ARE PROPRIETARY DATA AND EXCLUSIVE PROPERTY OF RSG PRODUCTS INC. AND IS DELIVERED ON THE EXPRESS CONDITION THAT NEITHER THIS DOCUMENT NOR THE INFORMATION CONTAINED HEREIN SHALL BE DISCLOSED TO OTHERS, REPRODUCED IN WHOLE OR IN PART, OR USED FOR THE MANUFACTURE OR FABRICATION OF PARTS FOR ANYONE OTHER THAN RSG PRODUCTS INC. WITHOUT WRITTEN CONSENT AND AUTHORIZATION, AND THAT NO RIGHT IS GRANTED TO DISCLOSE OR SO USE ANY INFORMATION CONTAINED IN SAID DOCUMENT. THIS RESTRICTION DOES NOT LIMIT THE RIGHT TO USE INFORMATION OBTAINED FROM ANOTHER SOURCE.</p>	<p>NEXT ASSY.</p>	<p>TOLERANCES EXCEPT AS SHOWN</p> <p>.X: ±.1 .XX: ±.03 .XXX: ±.010 X.X": ±.5° BREAK ALL SHARP EDGES .01 ALL DIMENSIONS IN INCHES UNLESS OTHERWISE STATED</p>	<p>RSG PRODUCTS INC. A ROTORCRAFT SERVICES GROUP COMPANY</p>		
	<p>APPROVED BY:</p>	<p>DATE:</p>		<p>TITLE: COMPRESSOR INSTALLATION</p>	
<p>DRAWN BY: S.THORNTON</p>		<p>DATE: 10/03/2012</p>	<p>REV.: F</p>	<p>SCALE: N/A</p>	<p>SHEET: 1 OF 3</p>
<p>APPLICATION: AS350</p>		<p>DWG. NO.: 6-3-AS350</p>			

- NOTES:
(APPLICABLE TO -02 CONFIGURATION ONLY)
- 1 PERMISSIBLE TO USE ALTERNATE COTTER PIN TYPE HARDWARE:
BOLT ANX-XX, NUT AN310-X, COTTER PIN MS24665-XXX.
 - 2 TIGHTEN BOTH NUTS AGAINST THE COMP MOUNT TENSION
BOLT. SAFETY WIRE NUTS USING ITEM 26 IAW MS33540.
 - 3 OLD AND NEW COMPRESSOR MOUNT BRACKET
04-130-21-101-01 TO REPLACE 530027-3.

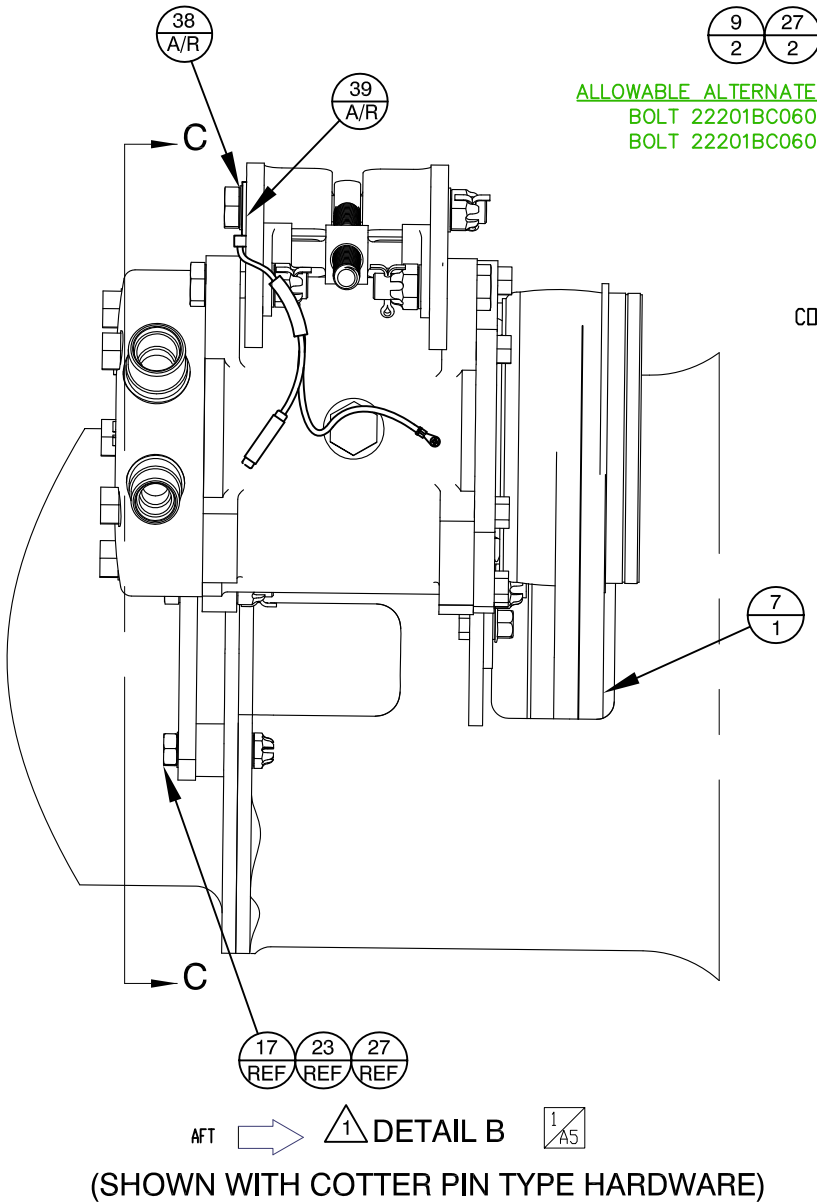

ALLOWABLE ALTERNATE METRIC HARDWARE
BOLT 22201BC060006L (X1)
BOLT 22201BC060027L (X2)

GEAR BOX
COUPLING CASE

PULLEY

SECTION C-C (VIEW LOOKING AFT)
(SHOWN WITH COTTER PIN TYPE HARDWARE)

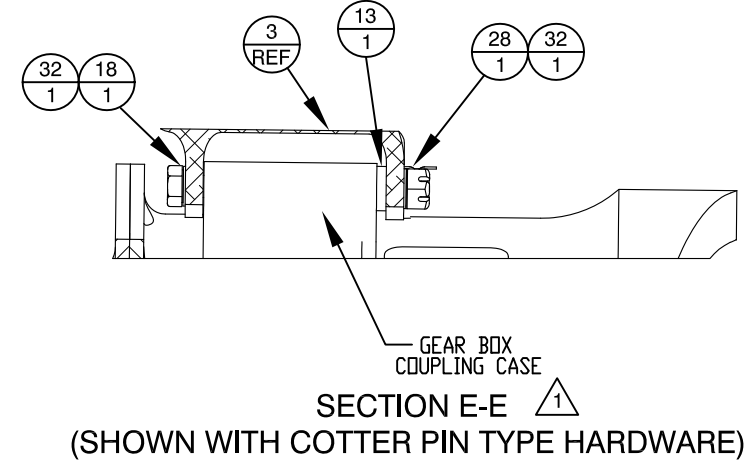
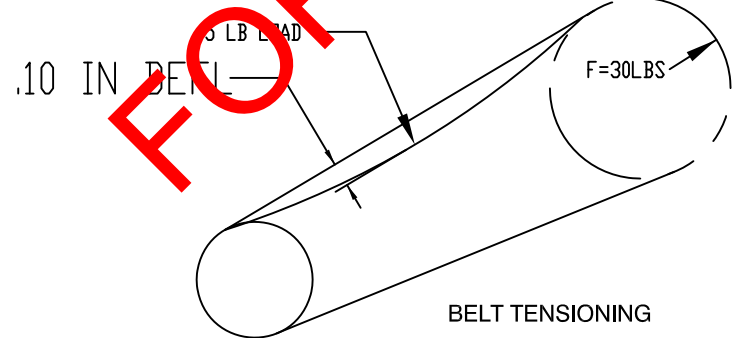

FOR REFERENCE ONLY

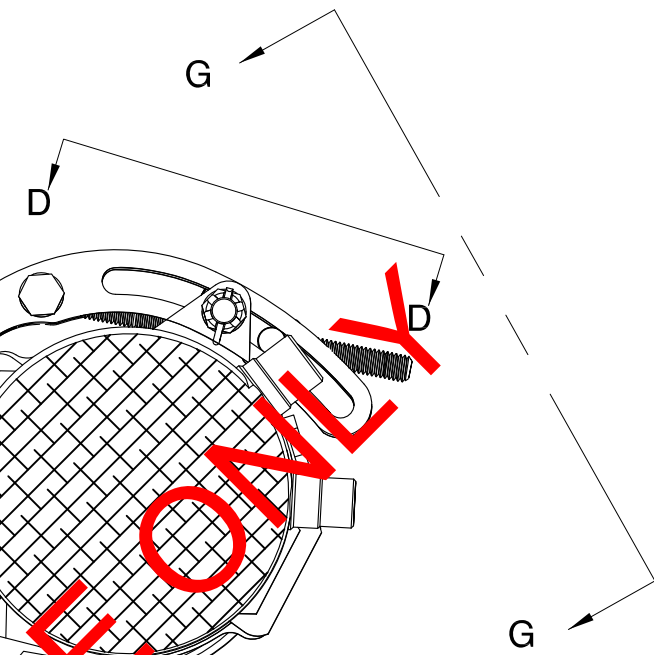

SECTION D-D (VIEW LOOKING DOWN)
(SHOWN WITH COTTER PIN TYPE HARDWARE)

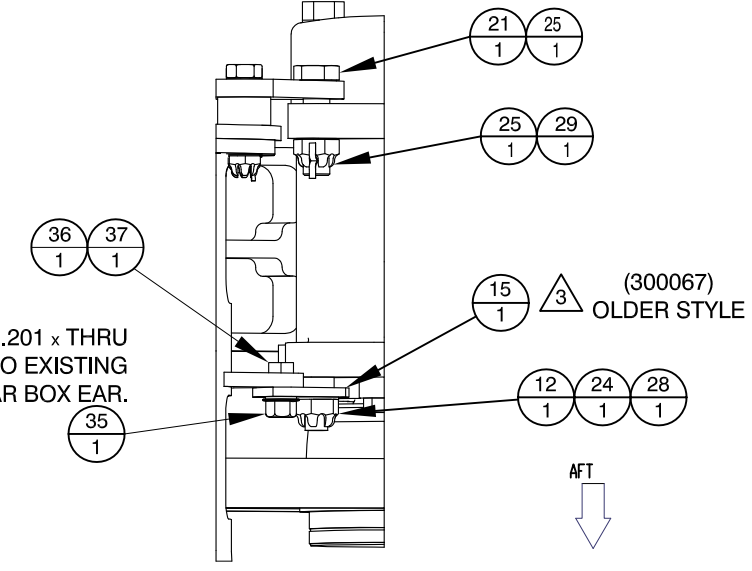

SECTION F-F (VIEW LOOKING UP.)
(SHOWN WITH COTTER PIN TYPE HARDWARE)

MATCH DRILL Ø.201 x THRU
ITEM 15 TO EXISTING
HOLE IN GEAR BOX EAR.

(300067)
OLDER STYLE



TITLE: COMPRESSOR INSTALLATION				
DRAWN BY: S. THORNTON	DATE: 10/03/2012	REV.: F	SCALE: N/A	SHEET: 2 OF 3
APPLICATION: AS350			DWG. NO.: 6-3-AS350	

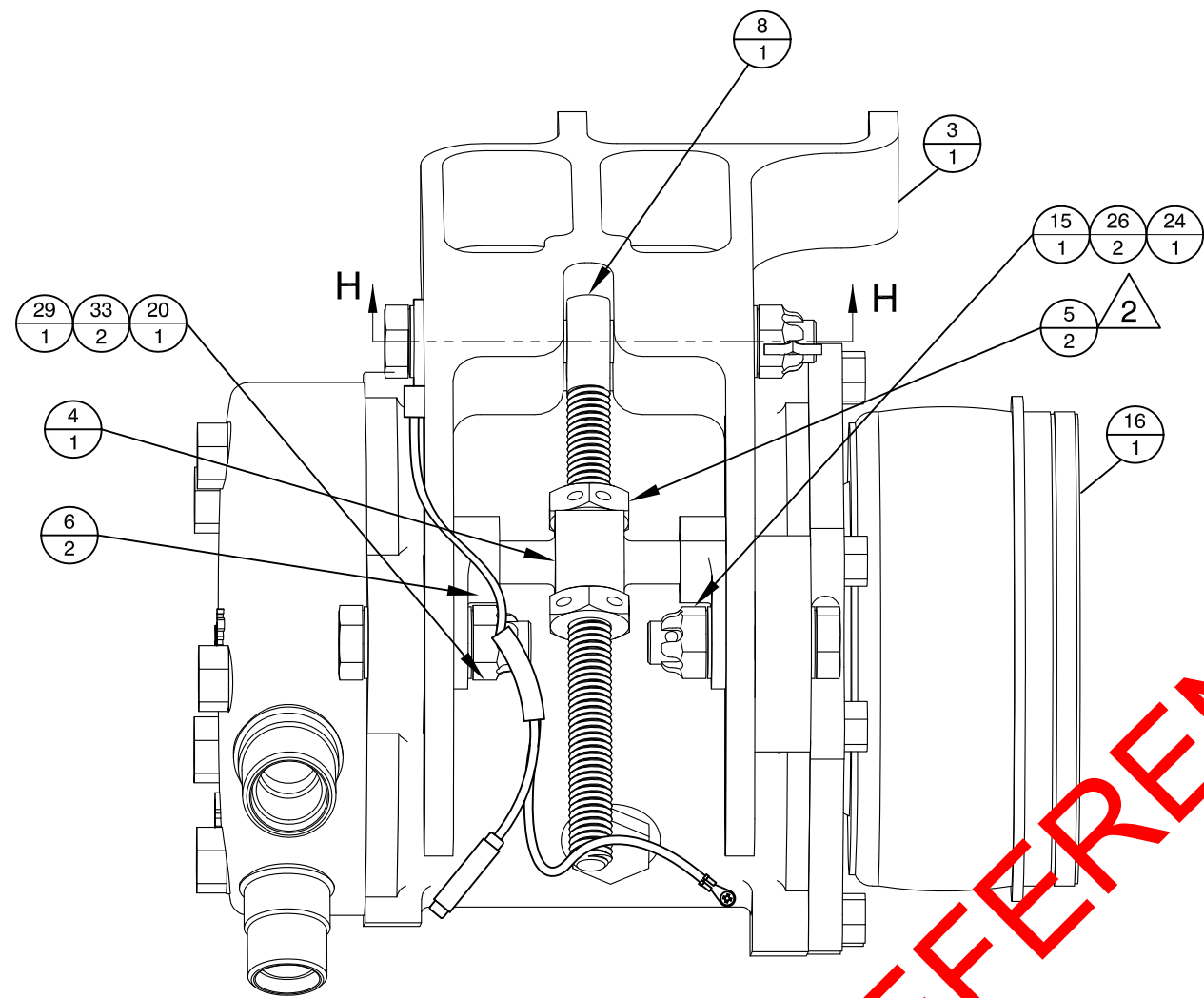

VIEW G-G $\triangle 1$
 (SHOWN WITH COTTER PIN TYPE HARDWARE)

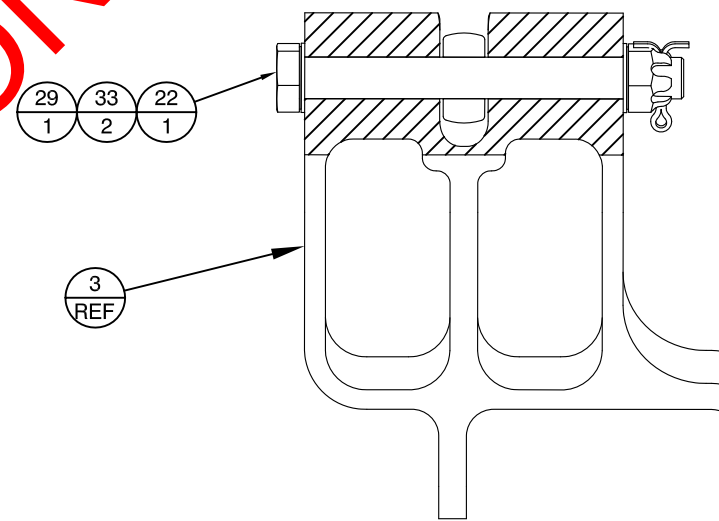

SECTION H-H $\triangle 1$
 (SHOWN WITH COTTER PIN TYPE HARDWARE)

FOR REFERENCE ONLY

-02 (CONTINUED)



TITLE: COMPRESSOR INSTALLATION				
DRAWN BY: S. THORNTON	DATE: 10/03/2012	REV.: F	SCALE: N/A	SHEET: 3 OF 3
APPLICATION: AS350			DWG. NO.: 6-3-AS350	



ENGINEERING CHANGE ORDER

ECO No.	1290	SHT	1 OF 1
DWG No.	6-3-AS350	REV	F
DWG No.		REV	
DWG No.		REV	
REF. STC No.	SH3509SW		
EFFECTIVITY:	<input type="checkbox"/> ALL UNITS THIS CUSTOMER <input type="checkbox"/> LIMITED UNITS SPECIFIED <input type="checkbox"/> ALL UNITS MFG'D AFTER THIS DATE <input checked="" type="checkbox"/> OTHER ALL UNITS		

CHANGE CLASS:

RECORD CHG. PARTS NOT AFFECTED NON-INTERCHANGEABLE PARTS
 INTERCHANGEABLE PARTS OTHER _____

EXISTING/IN-WORK STOCK DISPOSITION:

RECORD CHG. PARTS NOT AFFECTED RE-WORK EXISTING STOCK
 SCRAP EXISTING STOCK OTHER BREAK IN AT NEXT BUILD

DESCRIPTION OF CHANGE: CORRECT ALT. PART NUMBERS FOR ITEMS 23, 24 AND 25.

WAS:

2	A/R	25	AN960-616L	WASHER (ALT. AN960-616)		
1	3	24	AN960-516L	WASHER (ALT. AN960-516)		
4	4	23	AN960-416	WASHER (ALT. AN960-416L)		
QTY	QTY	ITEM	PART NUMBER	DESCRIPTION	VENDOR	WEIGHT

IS:

2	A/R	25	AN960-616L	WASHER (ALT. NAS1149F0632P)		
1	3	24	AN960-516L	WASHER (ALT. NAS1149F0532P)		
4	4	23	AN960-416	WASHER (ALT. NAS1149F0463P)		
QTY	QTY	ITEM	PART NUMBER	DESCRIPTION	VENDOR	WEIGHT

REMARKS: MINOR CHANGE.
CORRECTED ALT. P/N'S.

ENGINEERING REVIEW BOARD		
SIGNATURE	STAMP	DATE
	MRB04	1/13/2024
	QA22 PO16	1/18/2024 1/18/2024
INCORPORATION STATUS		
<input type="checkbox"/> IMMEDIATE <input checked="" type="checkbox"/> OUTSTANDING		



ENGINEERING CHANGE ORDER

ECO No.	1300	SHT 1 OF 2
DWG No.	6-3-AS350	REV F
DWG No.		REV
DWG No.		REV
REF. STC No.	SH3509SW	

CHANGE CLASS:

RECORD CHG. PARTS NOT AFFECTED NON-INTERCHANGEABLE PARTS

INTERCHANGEABLE PARTS OTHER _____

EXISTING/IN-WORK STOCK DISPOSITION:

RECORD CHG. PARTS NOT AFFECTED RE-WORK EXISTING STOCK

SCRAP EXISTING STOCK OTHER BREAK IN AT NEXT BUILD

EFFECTIVITY:

ALL UNITS THIS CUSTOMER LIMITED UNITS SPECIFIED

ALL UNITS MFG'D AFTER THIS DATE OTHER ALL UNITS

DESCRIPTION OF CHANGE: ADD MISSING HARDWARE PARTS FOR COMPRESSOR BRACKET KIT TO TABLE 1.

WAS:

FOR REFERENCE ONLY

TABLE 1
COMPRESSOR BRACKET KIT P/N: 350-11-011-01

ITEM DESCRIPTION	PART NUMBER	QTY
COMPRESSOR MOUNT BRACKET	04-130-21-101-01	1
COMPRESSOR MOUNT TENSION BOLT	04-130-21-102-01	1
JAM NUT, DRILLED	04-130-21-104-01	2
COMPRESSOR CLAMP	04-130-21-105-01	2
BUSHING, SD 507	261007	2
COMPRESSOR STANDOFF	300067-1	1
UPPER COMPRESSOR SHIM	300363-2	2
COMPRESSOR PIN	300095	1
STRAP HOUSING MOD ASSEMBLY	530100-1	1

REMARKS: MINOR CHANGE.
ADD MISSING PARTS.

ENGINEERING REVIEW BOARD		
SIGNATURE	STAMP	DATE
	MRB04	3/14/2024
	QA22	3/14/2024
	P016	3/15/2024
INCORPORATION STATUS		
<input type="checkbox"/> IMMEDIATE <input checked="" type="checkbox"/> OUTSTANDING		



ENGINEERING
CHANGE
ORDER

ECO No.	1300	SHT	2 OF 2
DWG No.	6-3-AS350	REV	F
DWG No.		REV	
DWG No.		REV	
REF. STC No.	SH3509SW		

IS:

TABLE 1
COMPRESSOR BRACKET KIT P/N: 350-11-031-02

ITEM DESCRIPTION	PART NUMBER	QTY	COMMENT
COMPRESSOR MOUNT BRACKET	04-130-21-101-01	1	
COMPRESSOR MOUNT TENSION BOLT	04-130-21-102-01	1	
JAM NUT, DRILLED	04-130-21-104-01	2	
COMPRESSOR CLAMP	04-130-21-105-01	2	
BUSHING, SD 507	261007	2	
COMPRESSOR STANDOFF	300067-1	1	
UPPER COMPRESSOR SHIM	300363-2	1	
COMPRESSOR PIN	300095	1	
STRAP, HOUSING MOD ASSEMBLY	530100-1	1	
THREADED ROD END	2434K39	1	
WASHER	NAS1149F0463H	1	OR NAS HARDWARE EQUIVALENT
WASHER	NAS1149F0635H	6	OR NAS HARDWARE EQUIVALENT
WASHER	NAS1149F0532H	2	OR NAS HARDWARE EQUIVALENT
WASHER	AN960-416	4	ALT (NAS1149F0463P)
WASHER	AN960-516L	1	ALT (NAS1149F0532P)
WASHER	AN960-616L	2	ALT (NAS1149F0632P)
NUT	MS21042-L5	2	ALT (MS20364-524C)
NUT	MS21042-L4	3	ALT (AN365-424)
NUT	MS21042L6	4	OR NAS HARDWARE EQUIVALENT
BOLT	AN4-5A	1	OR NAS HARDWARE EQUIVALENT
BOLT	AN4-14A	2	OR NAS HARDWARE EQUIVALENT
BOLT	AN5-34A	1	OR NAS HARDWARE EQUIVALENT
BOLT	AN6-13A	2	OR NAS HARDWARE EQUIVALENT
BOLT PER DRIVE	AN6-12	1	OR NAS HARDWARE EQUIVALENT
BOLT	AN6-33A	1	OR NAS HARDWARE EQUIVALENT

FOR REFERENCE ONLY

Step 9

Installation of Electrical

Installation of Electrical

STEP	PROCEDURE	MECH	INSP
9.1	Locate the electrical box support shelf, P/N 261375, per drawing 8-1-EC130 – Page 1.		
9.2	Locate the electrical box, P/N 540009, on the support shelf and match drill three each #10 holes. (Ref photo 901). Print 8-1-EC130		
9.3	Install the electrical box using three each, P/N AN525-10R6, screws.		
9.4	Install and route the electrical harness, P/N 540010 per drawing 2-1-EC130.		
9.5	Install and route electrical harness P/N 540045-1 using 8 x #10 ring terminal and P/N ANL-50 limiter per drawing 2-1-EC130.		
9.6	NOTE: Alternate mounting of electrical box may be performed if shelving is not installed at time of manufacture of aircraft.		
9.7	Install angle brackets, P/N 510265, P/N 260335. Per Print 8-2-EC130.		
9.8	Switch panel, P/N 540011, mounted under panel. Per Print 5-1-EC130, or Switch Panel P/N 540012 mounted in Instrument Panel.		

RSG Products Inc.
INSTALLATION OF ELECTRICAL– B4 Air Conditioning



Photo 901

Electrical Box and Shelf
Installation

NOTES:

USE EXISTING LIGHTENING HOLES ONLY FOR ALL ROUTING OR SECURE WIRES TO EXISTING BUNDLES OR REFRIGERATION HOSE USING TY-WRAPS, STAND-OFFS, AND SPACERS BLOCKS AS REQUIRED.

- ▶ LOCATION OF PRESSURE SWITCHES WHEN R-134a IS UTILIZED.
- ▶ ON B3 MODELS IFS WIRE ROUTING MUST BE ACCORDANCE WITH THIS DRAWING.
- ▶ INSTALL IFS104C14 TO LOW PRESSURE SWITCH. (BLUE LEADS)
- ▶ INSTALL IFS108B20 AND IFS108D20 TO HIGH PRESSURE SWITCH. (BLACK LEADS)

REVISION RECORD				
REV	DATE	DESCRIPTION OF CHANGE	APPVD. BY	REV. BY
A	08/14/09	REVISED TITLE BLOCK. EVAPORATOR BLOWER PART NO. WAS 490017 OR 490017-1, IS NOW 050143. ADDED ALTERNATE LOCATION FOR ELECTRICAL BOX. REVISED ELECTRICAL ROUTING. CHANGED RESISTOR ASSEMBLY PN TO 540020, ADDED ANL-50 LIMITER. ADDED LISTINGS OF INTERCHANGEABLE BLOWER ASSEMBLIES.		JTYE
B	09/01/14	CHANGED TITLE BLOCK AND REVISION BLOCK. INCORPORATED ECO # 0357.		AJC
C	08/04/23	REMOVED RESISTOR ASSEMBLY. INCORPORATED ECO 1027.		SGB

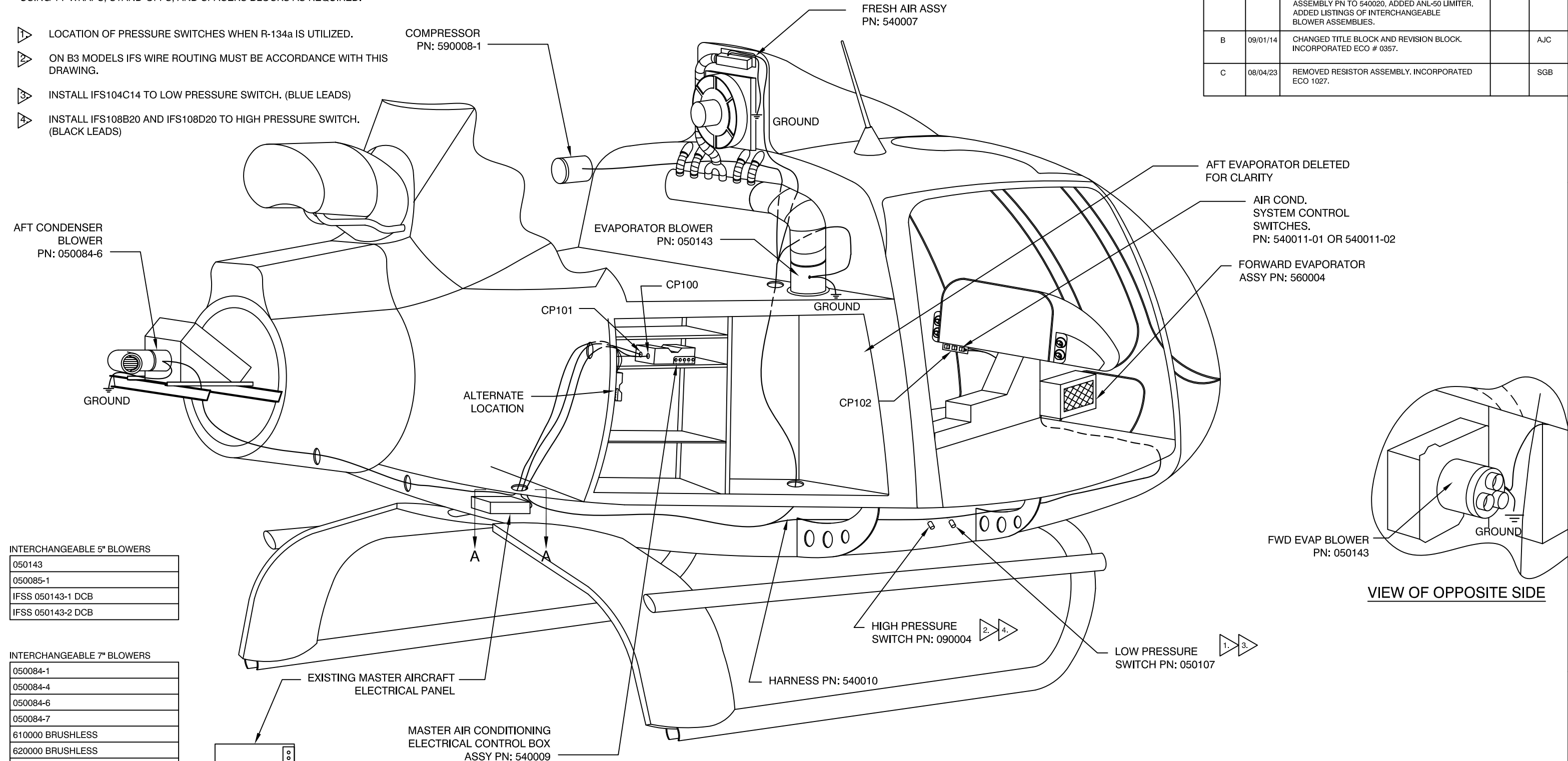

INTERCHANGEABLE 5" BLOWERS

050143
050085-1
IFSS 050143-1 DCB
IFSS 050143-2 DCB

INTERCHANGEABLE 7" BLOWERS

050084-1
050084-4
050084-6
050084-7
610000 BRUSHLESS
620000 BRUSHLESS
630000
640000
IFSS 050084-1
IFSS 050084-4
IFSS 050084-6
IFSS 050084-6-1
IFSS 050084-7 BRUSHLESS
IFSS 050084-7-1 BRUSHLESS

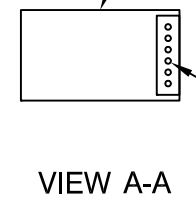
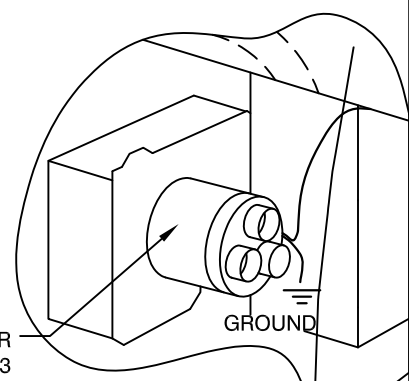

USE ANL-50 LIMITER, OR 50 AMP CIRCUIT BREAKER, OR FUSE AT PP-12 BUSS

<p>PROPRIETARY NOTICE</p> <p>TO ALL PERSONS RECEIVING THIS DOCUMENT THIS DOCUMENT AND INFORMATION OR TECHNICAL DATA AND DESIGNS CONTAINED HEREIN ARE PROPRIETARY DATA AND EXCLUSIVE PROPERTY OF RSG PRODUCTS INC. AND IS DELIVERED ON THE EXPRESS CONDITION THAT NEITHER THIS DOCUMENT NOR THE INFORMATION CONTAINED HEREIN SHALL BE DISCLOSED TO OTHERS, REPRODUCED IN WHOLE OR IN PART, OR USED FOR THE MANUFACTURE OR FABRICATION OF PARTS FOR ANYONE OTHER THAN RSG PRODUCTS INC. WITHOUT WRITTEN CONSENT AND AUTHORIZATION, AND THAT NO RIGHT IS GRANTED TO DISCLOSE OR SO USE ANY INFORMATION CONTAINED IN SAID DOCUMENT. THIS RESTRICTION DOES NOT LIMIT THE RIGHT TO USE INFORMATION OBTAINED FROM ANOTHER SOURCE.</p>	<p>NEXT ASSY.</p>	<p>TOLERANCES EXCEPT AS SHOWN</p> <p>.X: ±.1 .XX: ±.03 .XXX: ±.010 X.X": ±.5" BREAK ALL SHARP EDGES .01 ALL DIMENSIONS IN INCHES UNLESS OTHERWISE STATED</p>
	<p>APPROVED BY:</p>	<p>DATE:</p>

RSG PRODUCTS INC.
A ROTORCRAFT SERVICES GROUP COMPANY

TITLE:
ELECTRICAL ROUTING

DRAWN BY: JTYE	DATE: 06/15/03	REV.: C	SCALE: N/A	SHEET: 1 OF 1
APPLICATION: EC 130 B4			DWG. NO.: 2-1-EC130	

REVISION RECORD				
REV	DATE	DESCRIPTION OF CHANGE	APPVD. BY	REV. BY
A	12/05/03	REVISED TITLE BLOCK. WIRING NOTATION CHANGES. RE-DRAWN FOR CLARITY		JTYE
B	09/01/14	CHANGED TITLE BLOCK AND REVISION BLOCK. INCORPORATED ECO # 0613.		AJC

NOTES:
 1. FOR BRUSHLESS MOTORS: (P/N: IFSS 050143-1 DCB, IFSS 050143-2 DCB). WHEN EMI FILTER MODEL NUMBER 13619-RF16883 IS INSTALLED, TERMINATE FILTER INPUT AND OUTPUT TERMINALS WITH P/N: 51864-2, & GROUND TERMINAL WITH P/N: 51864-1. REFERENCE DRAWING 4-1-EC130 & 4-3-EC130 FOR MECHANICAL INSTALLATION OF EMI FILTER WHEN REQUIRED.

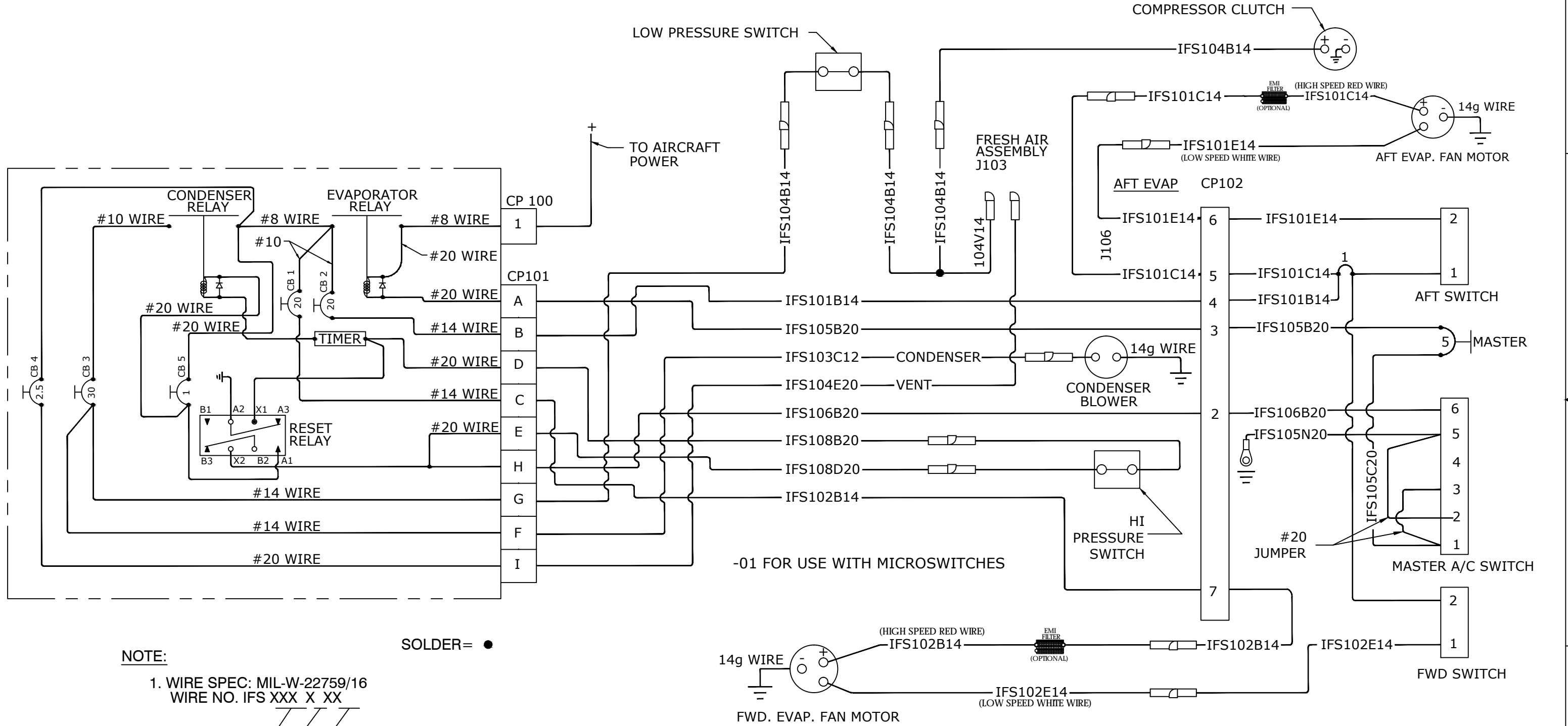

NOTE:
 1. WIRE SPEC: MIL-W-22759/16
 WIRE NO. IFS XXX X XX

GROUP
 SEQUENCE (N INDICATES GROUND)
 GAUGE

SOLDER= ●

-01 FOR USE OF MICROSWITCHES

EC 130 B4
ELECTRICAL WIRING DIAGRAM
SINGLE CONDENSER BLOWER

PROPRIETARY NOTICE TO ALL PERSONS RECEIVING THIS DOCUMENT THIS DOCUMENT AND INFORMATION OR TECHNICAL DATA AND DESIGNS CONTAINED HEREIN ARE PROPRIETARY DATA AND EXCLUSIVE PROPERTY OF RSG PRODUCTS INC. AND IS DELIVERED ON THE EXPRESS CONDITION THAT NEITHER THIS DOCUMENT NOR THE INFORMATION CONTAINED HEREIN SHALL BE DISCLOSED TO OTHERS, REPRODUCED IN WHOLE OR IN PART, OR USED FOR THE MANUFACTURE OR FABRICATION OF PARTS FOR ANYONE OTHER THAN RSG PRODUCTS INC. WITHOUT WRITTEN CONSENT AND AUTHORIZATION, AND THAT NO RIGHT IS GRANTED TO DISCLOSE OR SO USE ANY INFORMATION CONTAINED IN SAID DOCUMENT. THIS RESTRICTION DOES NOT LIMIT THE RIGHT TO USE INFORMATION OBTAINED FROM ANOTHER SOURCE.	NEXT ASSY.	TOLERANCES EXCEPT AS SHOWN .X: ±.1 .XX: ±.03 .XXX: ±.010 X.X": ±.5° BREAK ALL SHARP EDGES .01 ALL DIMENSIONS IN INCHES UNLESS OTHERWISE STATED DATE:
	APPROVED BY:	

RSG PRODUCTS INC.
 A ROTORCRAFT SERVICES GROUP COMPANY

TITLE:
ELECTRICAL DIAGRAM

DRAWN BY: JTYE	DATE: 06/15/03	REV.: B	SCALE: N/A	SHEET: 1 OF 2
APPLICATION: EC 130 B4			DWG. NO.: 2-3-EC130	

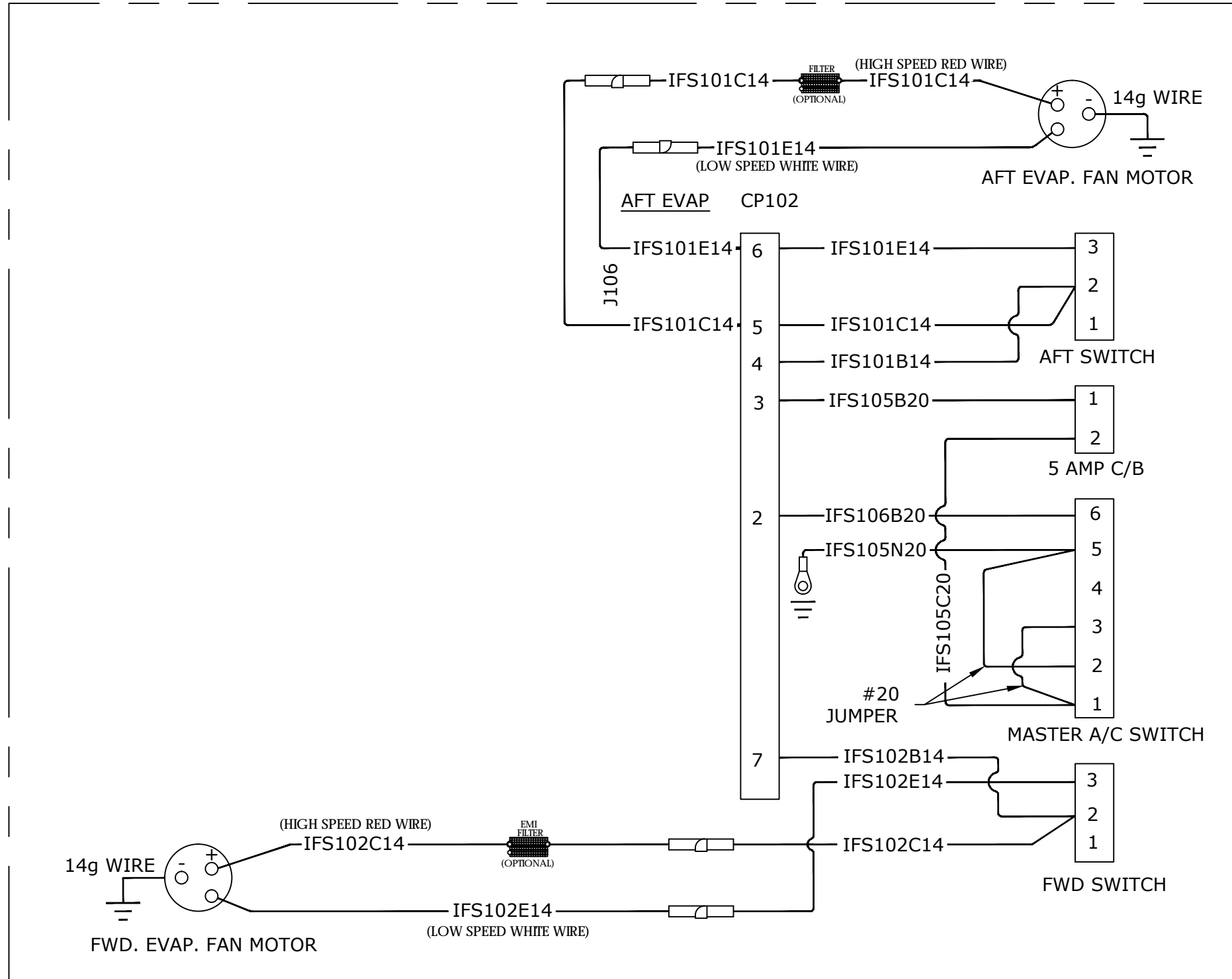

-02 FOR THE USE OF OLD STYLE SWITCHES



TITLE: ELECTRICAL DIAGRAM				
DRAWN BY: JT YE	DATE: 6/15/03	REV.: B	SCALE: N/A	SHEET: 2 OF 2
APPLICATION: EC 130 B4			DWG. NO.: 2-3-EC130	

REVISION RECORD				
REV	DATE	DESCRIPTION OF CHANGE	APPVD. BY	REV. BY
A	10/21/03	ADDED DIMENSIONS AND FLAG NOTE 1. ADDED DRILLING DIRECTIONS FOR ELECT. BOX SHELF PN: 261375.		JTYE
B	02/11/04	REVISED TITLE BLOCK. CHANGE SCREW CALL OUT FROM: 3X AN52510R7 TO: 3X AN52510R6 PER ECO 0104.		GB
C	9/1/14	CHANGED TITLE BLOCK AND REVISION BLOCK.		AJC

NOTES:
 1. DO NOT INSTALL TOO LOW, ALLOW CLEARANCE TO INSTALL ELT.

4.5"
 FROM TOP OF TOP
 TO BOTTOM OF BOTTOM

5.0"
 SHELF OPENING

LOCATE ELECTRIC BOX, PN:540009 ON SHELF AND MATCH DRILL SHELF TO NUTPLATES IN BOTTOM OF ELECTRIC BOX, ATTACH WITH 3X AN52510R6 SCREW.

LOCATE SHELF ALLOWING CLEARANCE FOR ELECTRIC BOX, DRILL 2X Ø.194 HOLES IN SHELF SUPPORT AND IN PN: 261375 ELECTRIC BOX SHELF. ATTACH WITH:
 4X AN52510R8 SCREW
 8X AN960-10 WASHER
 4X MS21083N3 NUT.



PROPRIETARY NOTICE		NEXT ASSY.	TOLERANCES EXCEPT AS SHOWN		
<small>TO ALL PERSONS RECEIVING THIS DOCUMENT THIS DOCUMENT AND INFORMATION OR TECHNICAL DATA AND DESIGNS CONTAINED HEREIN ARE PROPRIETARY DATA AND EXCLUSIVE PROPERTY OF RSG PRODUCTS INC. AND IS DELIVERED ON THE EXPRESS CONDITION THAT NEITHER THIS DOCUMENT NOR THE INFORMATION CONTAINED HEREIN SHALL BE DISCLOSED TO OTHERS, REPRODUCED IN WHOLE OR IN PART, OR USED FOR THE MANUFACTURE OR FABRICATION OF PARTS FOR ANYONE OTHER THAN RSG PRODUCTS INC. WITHOUT WRITTEN CONSENT AND AUTHORIZATION, AND THAT NO RIGHT IS GRANTED TO DISCLOSE OR SO USE ANY INFORMATION CONTAINED IN SAD DOCUMENT. THIS RESTRICTION DOES NOT LIMIT THE RIGHT TO USE INFORMATION OBTAINED FROM ANOTHER SOURCE.</small>		APPROVED BY:	.X: ±.1 .XX: ±.03 .XXX: ±.010 X.X°: ±.5° BREAK ALL SHARP EDGES .01 ALL DIMENSIONS IN INCHES UNLESS OTHERWISE STATED DATE:	TITLE: ELECTRIC BOX SHELF INSTALLATION	
					DRAWN BY: JTYE DATE: 06/15/03 REV.: C SCALE: N/A SHEET: 1 OF 1
					APPLICATION: EC 130 B4 DWG. NO.: 8-1-EC130

REVISION RECORD				
REV	DATE	DESCRIPTION OF CHANGE	APPVD. BY	REV. BY
A	11/03/04	REVISED TITLE BLOCK. ADDED 2 POSSIBLE MOUNTING CONFIGURATIONS.		JTYE
B	9/1/14	CHANGED TITLE BLOCK AND REVISION BLOCK.		AJC

NOTE:
MOUNT TO BULKHEAD TO ENSURE CLEARANCE OF ANY EXISTING HARDWARE OR OTHER MODIFICATIONS.

WHEN NO BATTERY COMPARTMENT SHELF IS PRESENT IN AIRCRAFT. UTILIZE 2X PN: 261334 (ALT:261335) AND 2X PN: 510265. LOCATE ELECTRICAL BOX AND DRILL 4X Ø.25 HOLES, 2X ON TOP, 2X ON BOTTOM, AT EQUAL SPACING. ATTACH USING:
4X- AN3-4A BOLT
8X- AN960-10 WASHER
4X- MS21044N3 LOCKNUT

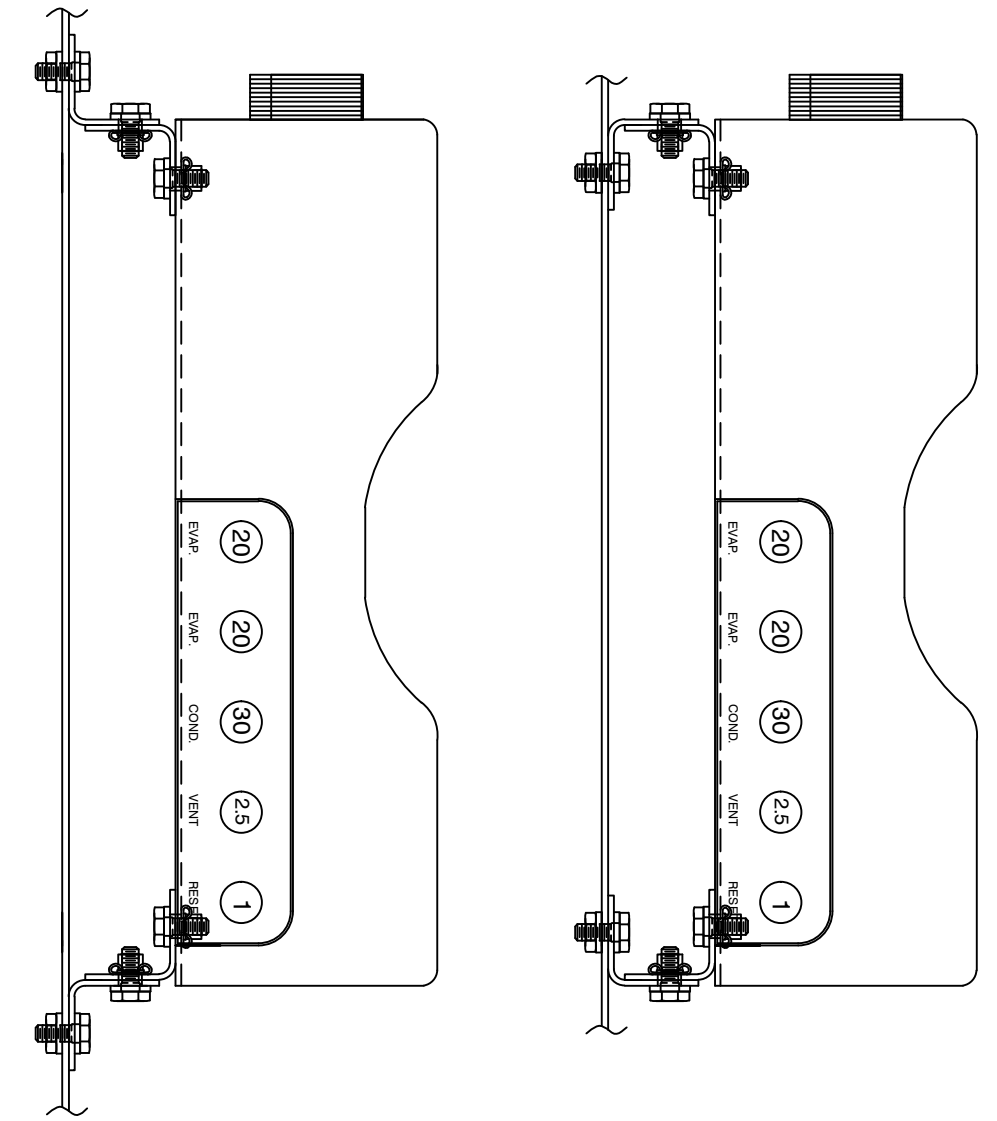
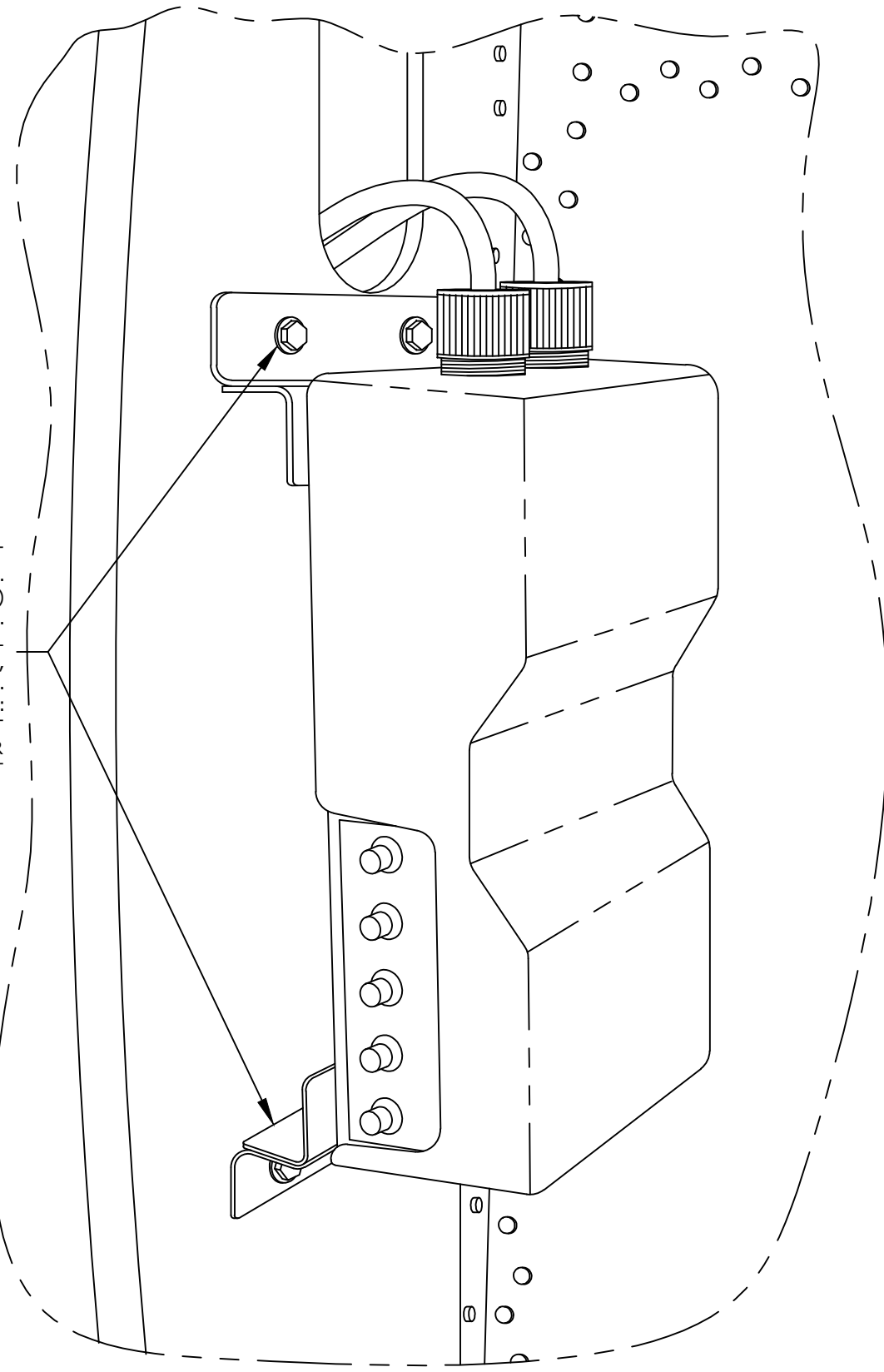

2 POSSIBLE MOUNTING CONFIGURATIONS SHOWN.

PROPRIETARY NOTICE TO ALL PERSONS RECEIVING THIS DOCUMENT THIS DOCUMENT AND INFORMATION OR TECHNICAL DATA AND DESIGNS CONTAINED HEREIN ARE PROPRIETARY DATA AND EXCLUSIVE PROPERTY OF RSG PRODUCTS INC. AND IS DELIVERED ON THE EXPRESS CONDITION THAT NEITHER THIS DOCUMENT NOR THE INFORMATION CONTAINED HEREIN SHALL BE DISCLOSED TO OTHERS, REPRODUCED IN WHOLE OR IN PART, OR USED FOR THE MANUFACTURE OR FABRICATION OF PARTS FOR ANYONE OTHER THAN RSG PRODUCTS INC. WITHOUT WRITTEN CONSENT AND AUTHORIZATION, AND THAT NO RIGHT IS GRANTED TO DISCLOSE OR SO USE ANY INFORMATION CONTAINED IN SAD DOCUMENT. THIS RESTRICTION DOES NOT LIMIT THE RIGHT TO USE INFORMATION OBTAINED FROM ANOTHER SOURCE.	NEXT ASSY.	TOLERANCES EXCEPT AS SHOWN .X: ±.1 .XX: ±.03 .XXX: ±.010 X.X°: ±.5° BREAK ALL SHARP EDGES .01 ALL DIMENSIONS IN INCHES UNLESS OTHERWISE STATED		
	APPROVED BY:	DATE:		TITLE: ELECTRIC BOX VERTICAL INSTALLATION
				DRAWN BY: JTYE DATE: 06/15/03 REV.: B SCALE: N/A SHEET: 1 OF 1
				APPLICATION: AS350/355, EC 130 B4 DWG. NO.: 8-2-EC130

Step 10

Installation of Hoses

Installation of Hoses

STEP	PROCEDURE	MECH	INSP
10.1	Locate the Dryer bottle mounting assembly, P/N 510381, install per drawing 3-1-EC130.		
10.2	WARNING: - Before connecting hoses be sure all fittings have R134 approved o-rings installed.		
10.3	Route evaporator return line hose assembly #10 suction hose (tee fitting above deck), P/N 570105, from the upper transmission deck down through the right side baggage compartment through the existing opening in the baggage compartment floor under the floor forward to the forward evaporator. The short length of hose connects to the aft evaporator return fitting above the transmission deck. The longer length above the transmission deck is routed against the cabin back wall to the compressor suction fitting located on the left side of the transmission. (Ref photo 1001)		
10.4	Route the evaporator expansion valve supply line high pressure hose assembly #6, P/N 570103, from the baggage compartment down through the existing opening in the baggage compartment floor under the floor forward to the forward evaporator. The tee fitting connects to the “out” or supply fitting on the dryer bottle. The short length to the evaporator.		
10.5	Clamp the coil on the end of the expansion valve to the return hose fitting (# 10 large line) with a 1- inch band clamp. Assure the fitting is clean where the coil is clamped. Insulate the coil completely with cork tape, P/N 070078-0.		
10.6	Route the condenser supply line hose assembly #8, P/N 570070-0-A, from the compressor discharge fitting against the cabin back wall to the right side of the transmission deck. Route down the same opening in the transmission deck as the return hose was routed through the baggage compartment out the bottom forward existing opening. Route under the floor aft and up through the existing hole in the back of the baggage floor into the tail boom under the baggage floor and up to the condenser. (Ref photo 1002)		

RSG Products Inc.
INSTALLATION OF HOSES – B4 Air Conditioning

Installation of Hoses

STEP	PROCEDURE	MECH	INSP
10.7	Route the line hose assembly, P/N 570104, down the existing forward opening in the baggage compartment. Route under the floor aft and up through the existing hole in the back of the baggage floor into the tail boom under the baggage floor and up to the condenser discharge fitting. (Ref photo 1003)		
10.8	Connect the hose end in the Baggage compartment to the “IN” or supply side of the dryer bottle 90-degree fitting. (Ref photo 1004)		

RSG Products Inc.
INSTALLATION OF HOSES– B4 Air Conditioning



Photo 1001

Rec/Drier mounting



RSG Products Inc.
INSTALLATION OF HOSES– B4 Air Conditioning



Photo 1002

Hose Routing

RSG Products Inc.
INSTALLATION OF HOSES– B4 Air Conditioning



Photo 1003

Hose Routing

RSG Products Inc.
INSTALLATION OF HOSES– B4 Air Conditioning



Photo 1004

Rec/Drier "IN" Side

ATTACH P/N 04-130-21-107-01 BRKT TO WALL & SECURE HOSES AS REQD. LOCATE FOR BEST FIT. SEE VIEW A ON DWG 3-2 EC130 FOR HOSECLAMP DETAIL. USE HOSE CLAMP MS21919WDG11 FOR #8 HOSE AND MS21919WDG12 FOR #10 HOSE.

SECURE HOSES TO WALL AS REQD. SEE VIEW A ON DWG 3-2 EC130 FOR HOSECLAMP DETAIL.

DRILL THRU TRANSMISSION DECK FOR HOSES, MATCH TO DOUBLER P/N 261370 LINE W/CATERPILLAR AND SEAL W/PRC OR PT-1

VIEW C-C
VIEW LOOKING FWD. AT STA. 115.01

COMPRESSOR
TRANS. DECK

- NOTES:**
- ▷ RESERVED
 - ▷ LOCATION OF PRESSURE SWITCHES WHEN R-134a COMPRESSOR IS INSTALLED.
 - ▷ 590008-1 R-134a W/ESTER OIL

VIEW B-B

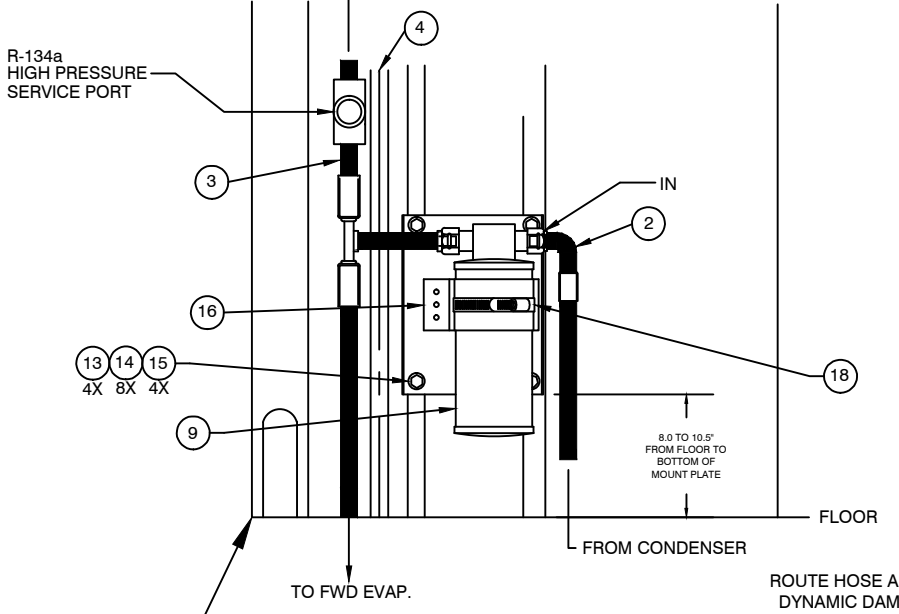

VIEW D-D
VIEW LOOKING DOWN

ROUT HOSES THROUGH EXISTING HOLE IN BAGGAGE COMPARTMENT FLOOR.

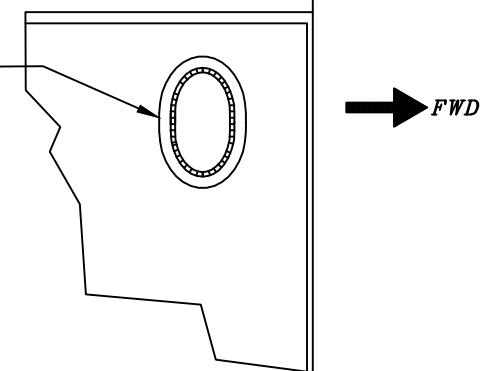

ROUTE HOSE AROUND DYNAMIC DAMPER

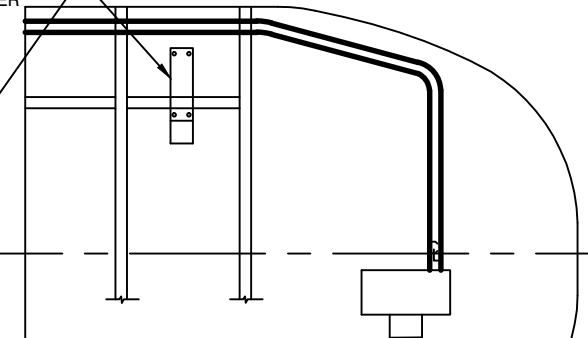

VIEW A-A
VIEW LOOKING UP



REVISION RECORD				
REV	DATE	DESCRIPTION OF CHANGE	APPVD. BY	REV. BY
A	10/15/03	REVISED TITLE BLOCK. VIEW B-B REDRAWN FOR CLARITY, DIMENSION TO FLOOR ADDED. PICTURE OF VIEW B-B ADDED.	MLD	JTYE
B	09/01/14	CHANGED TITLE BLOCK AND REVISION BLOCK. INCORPORATED ECO # 0405		AJC

QTY.	ITEM	PART NO.	DESCRIPTION	STOCK SIZE	MATL. DESC.	MATL. DESC.
1	18	3"	BAND CLAMP			
2	17	090002-0"	EXPANSION VALVE			
1	16	510381	REC/DRIER MOUNT			
4	15	MS21044-N3	NUT			
8	14	AN960-10	WASHER			
4	13	AN3-5A	BOLT			
1	12	560016-0	AFT EVAPORATOR			
1	11	590008-1	COMPRESSOR 24VDC			
1	10	550003-0	CONDENSER ASSY			
1	9	090016-5	RECIEVER/DRIER			
1	8	050107	LOW PRESSURE SWITCH			
1	7	090004	HIGH PRESSURE SWITCH			
1	6	560006	FWD EVAPORATOR ASSY.			
1	5	570070-O-A	HOSE ASSY, COMP TO COND. #8			
1	4	570105	RETURN HOSE ASSY. #10			
1	3	570103	HIGH PRESS. HOSE #6			
1	2	570104	HOSE ASSY, COND-REC/DRIER #6			
			PLUMBING DIAGRAM			

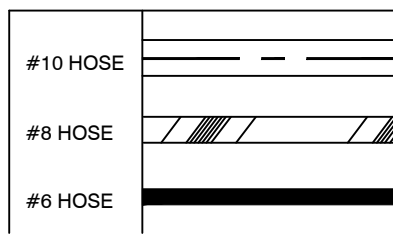

PROPRIETARY NOTICE

TO ALL PERSONS RECEIVING THIS DOCUMENT THIS DOCUMENT AND INFORMATION OR TECHNICAL DATA AND DESIGNS CONTAINED HEREIN ARE PROPRIETARY DATA AND EXCLUSIVE PROPERTY OF RSG PRODUCTS INC. AND IS DELIVERED ON THE EXPRESS CONDITION THAT NEITHER THIS DOCUMENT NOR THE INFORMATION CONTAINED HEREIN SHALL BE DISCLOSED TO OTHERS, REPRODUCED IN WHOLE OR IN PART, OR USED FOR THE MANUFACTURE OR FABRICATION OF PARTS FOR ANYONE OTHER THAN RSG PRODUCTS INC. WITHOUT WRITTEN CONSENT AND AUTHORIZATION, AND THAT NO RIGHT IS GRANTED TO DISCLOSE OR SO USE ANY INFORMATION CONTAINED IN SAD DOCUMENT. THIS RESTRICTION DOES NOT LIMIT THE RIGHT TO USE INFORMATION OBTAINED FROM ANOTHER SOURCE.

APPROVED BY: _____

TOLERANCES EXCEPT AS SHOWN
 .X: ±.1
 .XX: ±.03
 .XXX: ±.010
 X.X": ±.5°
 BREAK ALL SHARP EDGES .01
 ALL DIMENSIONS IN INCHES UNLESS OTHERWISE STATED
 DATE: _____

RSG PRODUCTS INC.
A ROTORCRAFT SERVICES GROUP COMPANY

TITLE:
PLUMBING DIAGRAM

DRAWN BY: JTYE	DATE: 06/15/03	REV.: B	SCALE: N/A	SHEET: 1 OF 2
APPLICATION: EC 130 B4			DWG. NO.: 3-1-EC 130	

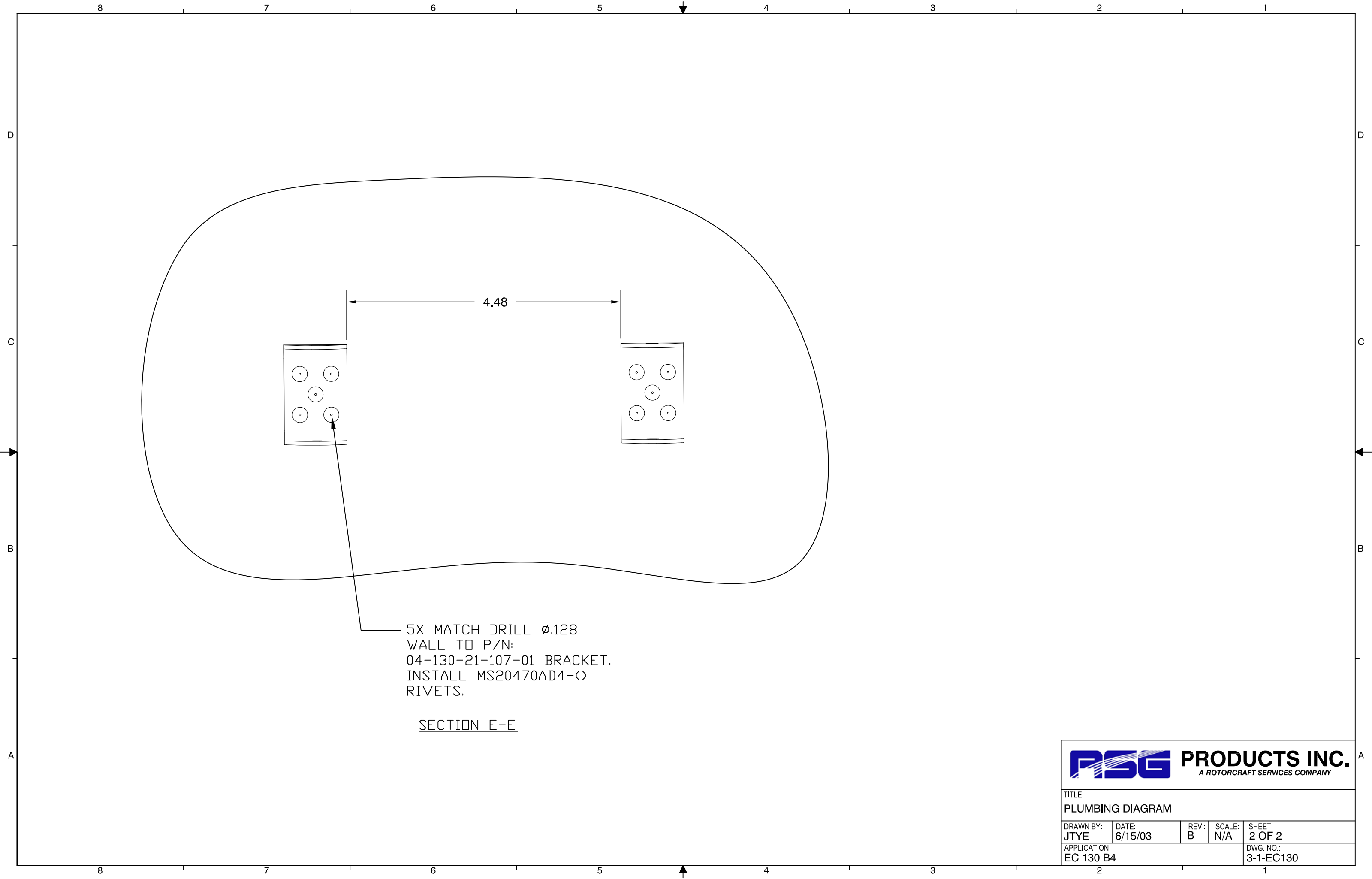

5X MATCH DRILL ϕ .128
 WALL TO P/N:
 04-130-21-107-01 BRACKET.
 INSTALL MS20470AD4-(\curvearrowright)
 RIVETS.

SECTION E-E

TITLE: PLUMBING DIAGRAM				
DRAWN BY: JT YE	DATE: 6/15/03	REV.: B	SCALE: N/A	SHEET: 2 OF 2
APPLICATION: EC 130 B4			DWG. NO.: 3-1-EC130	

REVISION RECORD				
REV	DATE	DESCRIPTION OF CHANGE	APPVD. BY	REV. BY
A	03/31/09	REVISED TITLE BLOCK.		DWE
B	9/1/14	CHANGED TITLE BLOCK AND REVISION BLOCK.		AJC

EXTREMELY IMPORTANT
FAILURE TO SECURE EXPANSION VALVE SENSING BULB, TIGHTLY, TO THE RETURN LINE HOSE FITTING (#10) WITH A STAINLESS STEEL CLAMP (AND INSULATE SENSING BULB & LINE) WILL DRAMATICALLY DECREASE THE PERFORMANCE OF THE AFT EVAPORATOR (NOT FORWARD).

SECURE HOSES TO FIREWALL
SEE DWG 3-1-EC130 (SH 1 OF 1)
VIEW C-C

CONDENSER

COMPRESSOR



AFT EVAPORATOR
EXPANSION VALVE

FWD EVAPORATOR

SEE DWG 3-1-EC130
(SH 1 OF 1),
VIEW D-D

LOW PRESSURE SWITCH
P/N 050107



VIEW A

HIGH PRESSURE SWITCH
P/N 090004

AN3-4A BOLT OR
AN525-10R10 SCREW
AN960-10 WASHER
MS21044-N3 NUT

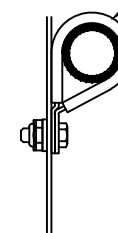

VIEW A

TYPICAL HOSE INSTALLATION:

FOR #6 HOSE ATTACH WITH TIE WRAP

FOR #8 HOSE ATTACH WITH TIE WRAP

FOR #10 HOSE ATTACH WITH ADEL CLAMP, TIE WRAP AND
MS21919DG12 & HARDWARE AS SHOWN

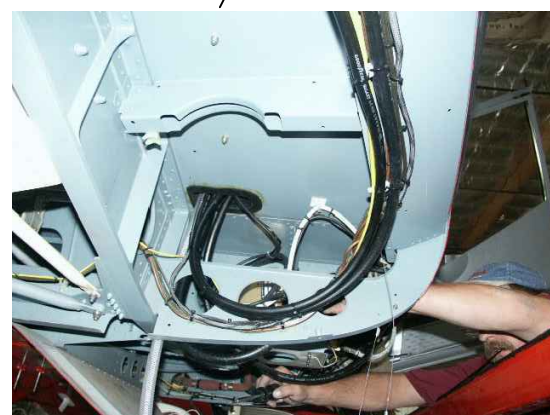

PROPRIETARY NOTICE

TO ALL PERSONS RECEIVING THIS DOCUMENT THIS DOCUMENT AND INFORMATION OR TECHNICAL DATA AND DESIGNS CONTAINED HEREIN ARE PROPRIETARY DATA AND EXCLUSIVE PROPERTY OF RSG PRODUCTS INC. AND IS DELIVERED ON THE EXPRESS CONDITION THAT NEITHER THIS DOCUMENT NOR THE INFORMATION CONTAINED HEREIN SHALL BE DISCLOSED TO OTHERS, REPRODUCED IN WHOLE OR IN PART, OR USED FOR THE MANUFACTURE OR FABRICATION OF PARTS FOR ANYONE OTHER THAN RSG PRODUCTS INC. WITHOUT WRITTEN CONSENT AND AUTHORIZATION, AND THAT NO RIGHT IS GRANTED TO DISCLOSE OR SO USE ANY INFORMATION CONTAINED IN SAD DOCUMENT. THIS RESTRICTION DOES NOT LIMIT THE RIGHT TO USE INFORMATION OBTAINED FROM ANOTHER SOURCE.

NEXT ASSY.

APPROVED BY:

TOLERANCES EXCEPT AS SHOWN

.X: ±.1
.XX: ±.03
.XXX: ±.010
X.X°: ±.5°
BREAK ALL SHARP EDGES .01
ALL DIMENSIONS IN INCHES UNLESS OTHERWISE STATED
DATE:



RSG PRODUCTS INC.
A ROTORCRAFT SERVICES GROUP COMPANY

TITLE:
PLUMBING ROUTING

DRAWN BY: **JTYE** DATE: **06/15/03** REV.: **B** SCALE: **N/A** SHEET: **1 OF 1**

APPLICATION: **EC 130 B4** DWG. NO.: **3-2-EC130**

Step 11

Paperwork



DATE:
08/04/2023

DOC No.:
IFSE-0007

REV:
F-1

PAGE:
98 of 99

TITLE:
Air Conditioning System Installation Instructions For Continued
Airworthiness for Airbus Helicopters AS-350 B, C, D, D1, B1, B2, B3, BA &
EC-130 B4

PERTAINS TO KIT # 130-00-031
Weight (#) X Arm (") = Moment ("#)

ITEM	WEIGHT (#)	ARM (")	MOMENT ("#)
FWD. EVAP ASSY W/ MOTOR	14.0	24.0	336
FWD AIR OUTLETS (x2) W/ DUCTING	3.0	33.29	99.87
AFT EVAP W/ MOTOR & DUCTS	16.0	120.5	1928
CONDENSER ASSY W/ MOTOR & AIR DISCHARGE	33.0	223.3	7368.9
COMPRESSOR W/ MOUNTING KIT	17.5	147.8	2586.5
ELECTRICAL CONTROL BOX	4.0	153.7	614.8
REFRIGERANT HOSES	5.0	76.9	384.5
ELECTRICAL HARNESS	3.5	70.0	245
INSTALLATION TOTALS	96.0		13563.57



United States of America
Department of Transportation
Federal Aviation Administration

Supplemental Type Certificate

Number: SH3509SW

This certificate issued to: RSG Products Inc.
440 West Lane Suite 100
Saginaw TX, 76131

Certifies that the change in the type design for the following product with the limitations and conditions therefore as specified hereon meets the airworthiness requirements of 27 of Federal Aviation Regulations

Original Product *Make:* Airbus Helicopters
Type Certificate Number: H9EU *Model:* AS350 B, B1, B2, B3, BA, C, D, D1;
Description of Type Design Change: EC130B4

Installation of a Single and Dual Condenser Blower Air Conditioning System in accordance with Integrated Flight Systems (IFS) Master Drawing List (MDL), Document No. DL-9 (Vapor Cycle Air Conditioning System with Belt Driven Compressor Utilizing Refrigerant R134a), Rev. T, dated 09/01/2014, or later FAA approved revision.

(See continuation sheet 3 of 3)

Limitations and Conditions:

The installer must determine whether this design change is compatible with previously approved modifications. If the holder agrees to permit another person to use this certificate to alter a product, the holder must give the other person written evidence of that permission.

This certificate and the supporting data which is the basis for approval shall remain in effect until surrendered, suspended, revoked, or a termination date is otherwise established by the Administrator of the Federal Aviation Administration.

Date of Application: September 10, 1984 *Date Reissued:* April 30, 1991; August 22, 2001; October 23, 2008; August 26, 2011; November 29, 2021
Date of Issuance: September 20, 1985 *Date Amended:* February 11, 1999; February 9, 2009; February 23, 2009; November 5, 2010; September 14, 2015

By Direction of the Administrator

Signature: Jim Grigg
Title: Manager, Fort Worth ACO Branch
Compliance & Airworthiness Division
Aircraft Certification Service

Any alteration of this certificate is punishable by a fine of not exceeding \$1,000, or imprisonment not exceeding 3 years, or both. This certificate may be transferred or made available to third persons by licensing agreements in accordance with 14 CFR 21.47. Possession of this Supplemental Type Certificate (STC) document by persons other than the STC holder does not constitute rights to the design data nor to alter an aircraft, aircraft engine, or propeller. The STC's supporting documentation (drawings, instructions, specifications, flight manual supplements, etc.) is the property of the STC holder. An STC holder who allows a person to use the STC to alter an aircraft, aircraft engine, or propeller must provide that person with written permission acceptable to the FAA. (Ref. 14 CFR 21.120).



United States of America
Department of Transportation
Federal Aviation Administration
Supplemental Type Certificate

Number: SH3509SW

INSTRUCTIONS: The transfer endorsement below may be used to notify the appropriate FAA Aircraft Certification Office of the transfer of this Supplemental Type Certificate. The FAA will reissue the certificate in the name of the transferee and forward it to him.

Transfer Endorsement

Transfer the ownership of Supplemental Type Certificate Number: _____

To (Name and address of transferee):

From (Name and address of grantor):

Extent of Authority (if licensing agreement):

Date of transfer:

Signature of grantor: _____

Any alteration of this certificate is punishable by a fine of not exceeding \$1,000, or imprisonment not exceeding 3 years, or both. This certificate may be transferred or made available to third persons by licensing agreements in accordance with 14 CFR 21.47. Possession of this Supplemental Type Certificate (STC) document by persons other than the STC holder does not constitute rights to the design data nor to alter an aircraft, aircraft engine, or propeller. The STC's supporting documentation (drawings, instructions, specifications, flight manual supplements, etc.) is the property of the STC holder. An STC holder who allows a person to use the STC to alter an aircraft, aircraft engine, or propeller must provide that person with written permission acceptable to the FAA. (Ref. 14 CFR 21.120).



United States of America
 Department of Transportation
 Federal Aviation Administration
Supplemental Type Certificate

(Continuation Sheet)

Number: SH3509SW

Date of Issuance: September 20, 1985

Date Reissued: November 29, 2021

Description of Type Design Change

For Single Condenser Configurations the following FAA Approved Flight Manual Supplements (FMSs) and revisions, or later FAA approved revisions, are required accordingly:

- AS350B, C, D, D1: FMS 19-350-21-002-011, Rev. D, dated 11/17/2014.
- AS350B1: FMS 19-350-21-004-011, Rev. C, dated 11/17/2014.
- AS350B2: FMS 19-350-21-006-011, Rev. B, dated 11/17/2014.
- AS350B3: FMS 19-350-21-008-011, Rev. B, dated 11/17/2014.
- AS350BA: FMS 19-350-21-010-011, Rev. B, dated 11/17/2014.
- EC130B4: FMS dated 2/6/04.

For Dual Condenser Configurations the following FAA approved FMSs and revisions, or later FAA approved revisions, are required accordingly:

- AS350B, C, D, D1: FMS 19-350-21-001-031, Rev. D, dated 11/17/2014.
- AS350B1: FMS 19-350-21-003-031, Rev. C, dated 11/17/2014.
- AS350B2: FMS 19-350-21-005-031, Rev. B, dated 11/17/2014.
- AS350B3: FMS 19-350-21-007-031, Rev. B, dated 11/17/2014.
- AS350BA: FMS 19-350-21-009-031, Rev. B, dated 08/18/2015.

Instructions for Continued Airworthiness, IFS Document No. IFSE-0007, Rev. C, dated 8/12/2010, or later revision is required.

-----END-----

Any alteration of this certificate and/or the Type Certificate Data Sheet is punishable by a fine not exceeding \$1,000, or imprisonment not exceeding 3 years, or both. This certificate may be transferred or made available to third persons by licensing agreements in accordance with Title 14 of the Code of Federal Regulations, part 21, section 21.47 (14 CFR 21.47). A transfer must be endorsed as provided on the reverse hereof. A Type Certificate holder who allows a person to use the Type Certificate to manufacture a new aircraft, aircraft engine, or propeller must provide that person with a written licensing agreement acceptable to the FAA. (Ref. 14 CFR 21.55).

RSG Products Inc.



Transport
Canada
Civil Aviation

Transports
Canada
Aviation Civile

Suite 620
800 Burrard Street
Vancouver, B.C.
V6Z 2J8

Your file *Votre référence*

Our file *Notre référence*
P-03-0350

July 8, 2003

Integrated Flight Systems, subsidiary
of Platinum Aviation Group, Inc.
4655 Aircenter Circle
Reno, Nevada 89502

Attn: Mr. Leroy Aday, President

Subject: Acceptance of FAA STCs SH3509SW and SH5947SW

Dear Mr. Aday:

This letter is in response to your application for Canadian acceptance of FAA STCs SH3509SW and SH5947SW, submitted to our office June 13, 2003, by the FAA Los Angeles Aircraft Certification Office.

In accordance with current Transport Canada policy concerning review of FAA-issued STCs for non-US state-of-design Normal Category rotorcraft, both STCs have been accepted in Canada without having to issue corresponding Canadian certificates.

Both FAA STC's will be entered into the national index of STCs that have been reviewed and accepted by Transport Canada for installation on Canadian-registered aeronautical products.

This letter confirms formal acceptance of the referenced STC by Transport Canada.

If you have any questions concerning this matter, I can be contacted by telephone at (604) 666-5269.

Yours truly,

David Bafia

For Regional Manager,
Aircraft Certification

Canada 



AGÊNCIA NACIONAL DE AVIAÇÃO CIVIL - BRASIL

CERTIFICADO DE HOMOLOGAÇÃO SUPLEMENTAR DE TIPO
(Supplemental Type Certificate)

NÚMERO 2006S12-09
(Number)

Este certificado, emitido com base na Lei nº 7565 "Código Brasileiro de Aeronáutica", de 19 de dezembro de 1986,
(This certificate, issued in the basis of the Law No. 7565 "Código Brasileiro de Aeronáutica", dated 19 December 1986,

é conferido ao (à): Integrated Flight Systems Corp.
is granted to:) 4607 B. Aircenter Circle
Reno, Nevada 89502
USA

por ter a modificação ao projeto de tipo do produto abaixo citado, observadas as limitações e condições
(for having the change to the type design of the product mentioned below, with the limitations and conditions thereof as)
especificadas, satisfeito aos requisitos de aeronavegabilidade aplicáveis.
(specified hereon, met the applicable airworthiness requirements.)

Produto Original - Número do Certificado de Tipo: 8812 (ANAC).
(Original Product - Type Certificate No.)

Fabricante: Eurocopter France.
(Manufacturer:)

Modelo(s): AS 350 B1, AS 350 B2, AS 350 B3, AS 350 BA and.
(Model(s):) EC 130 B4.

DESCRIÇÃO DA MODIFICAÇÃO AO PROJETO DE TIPO:
(Description of Type Design Change:)

Installation of a Belt-Driven Freon Air Conditioning System in accordance with Integrated Flight Systems Drawing List No. DL-9 (single Condenser blower), Rev. J, dated 5 Dec. 2003, or later approved revision or Drawing List No. DL-9-1 (Dual Condenser blower), Rev. NC, dated 1 Jan. 1992, or later approved revision.

This CHST validates in Brazil the STC # SH3509SW, issued by FAA (USA).

LIMITAÇÕES E CONDIÇÕES:
(Limitations and Conditions:)

See continuation sheet for applicable data.

DATAS:
(Dates of:)

Do Requerimento: 28 Aug. 2006
(Application:)

Da emissão: 13 Dec. 2006
(Issue:)

Da reemissão:
(Reissue:)

CLÁUDIO PASSOS SIMÃO

Gerente Geral, Certificação de Produtos Aeronáuticos
(Manager, Aeronautical Products Certification)

MILTON ZUANAZZI
Diretor-Presidente
(Director President)



AGÊNCIA NACIONAL DE AVIAÇÃO CIVIL

Folha de Continuação ao
(Continuation Sheet to)

CERTIFICADO DE HOMOLOGAÇÃO SUPLEMENTAR DE TIPO
(Supplemental Type Certificate)

NÚMERO 2006S12-09
(Number)

LIMITAÇÕES E CONDIÇÕES:
(Limitations and Conditions:)

- I. The approval of this type design change should not be extended to other aircraft of these models on which other previously approved modifications are incorporated unless it is determined by the installer that the relationship between this change and any of those other previously approved modifications, including changes in Type Design, will introduce no adverse effect upon the airworthiness of that aircraft.
- II. If the holder agrees to permit another person to use this certificate to alter the product, the holder shall give the other person written evidence of that permission.
- III. This installation is approved only for VFR operations.
- IV. Operation must be performed in accordance with the FAA approved Helicopter Flight Manual Supplement (FMS), as applicable:
 - Model AS 350 B1, requires FMS, Rev. A, dated 30 Apr. 1991 or later FAA approved revision;
 - Model AS 350 B2, requires FMS, Rev. NC, dated 30 Apr. 1991 or later FAA approved revision;
 - Model AS 350 B3, requires FMS, Rev. NC, dated 8 Feb. 1999 or later FAA approved revision;
 - Model AS 350 BA, requires FMS, Rev. NC, dated 15 May 1992 or later FAA approved revision;
 - Model EC 130 B4, requires FMS, Rev. NC, dated 6 Feb. 2004 or later FAA approved revision.
- V. For the Instructions for Continued Airworthiness, see the Operators Manual supplied with the Air Conditioning Kits.
- VI. A copy of this Certificate and the Supplement referred on item IV above shall be maintained as part of the permanent records of the modified aircraft.

----- END -----

Two handwritten signatures in blue ink are present below the dashed line. The first signature appears to be "Pawar" and the second is a stylized signature.



European Aviation Safety Agency

SUPPLEMENTAL TYPE CERTIFICATE

EASA.IM.R.S.01243

This certificate, established in accordance with Regulations (EC) No 1592/2002 and (EC) No 1702/2003 and issued to:

Integrated Flight Systems Corp.
4607 B Aircentre Circle
Reno
Nevada 89502
USA

certifies that the change in the type design for the product listed below with the limitations and conditions specified meets the applicable type certification basis and environmental protection requirements when operated within the conditions and limitations specified below:

Original Product Type Certificate number: *EASA TCDS EASA.R.008*

Manufacturer: *Eurocopter*

Model: *AS 350 B, B1, B2, B3, BA, D, EC130B4*

Original STC Number: *SH3509SW*

Description of Design Change:

Installation of a Belt Driven Freon Air Conditioning System (FAA STC SH3509SW).



Associated Technical Documentation:

- DL-9 rev A dated 12 Sept 1985 – Drawing List, Single Condenser Blower
- DL-9-1 rev N/C dated 10 Jan 1992 – Drawing List, Dual Condenser Blowers
- Models AS350B & D, FMS dated 26 June 1985 or later approved revision
- Model AS 350B1, FMS dated 27 October 1988 or later approved revision
- Model AS350B2, FMS dated 30 April 1991 or later approved revision
- Model AS350BA, FMS dated 15 May 1992 or later approved revision
- Model AS350B3, FMS dated 8 February 1999 or later approved revision
- Model EC130B4, RFM-130-00-031HP rev Original dated 6 February 2004 or later approved revision

Limitations and Conditions:

1. VFR Operations only
2. This STC is approved only for the product configuration as defined in the approved design data referred to in the paragraphs "Description" and "Associated Technical Documentation". Compatibility with other aircraft/engine configurations shall be determined by the installer.

This certificate shall remain valid unless otherwise surrendered or revoked.

For the European Aviation Safety Agency,
Date of Issue: 26 April 2007

Massimo Mazzoletti
Certification Manager
Rotorcraft, Balloons & Airships



DRAWING NUMBER	DRAWING TITLE	# OF PAGES	DRAWING DATE	REVISION	DESCRIPTION	AS 350	EC130B4	SIZE	NEW/RVSD
1-0-AS350	AIR CONDITIONING CONFIGURATION CONTROL	2	01/19/22	D	AS 350	X		B	TO REV. D
1-0-EC130	AIR CONDITIONING CONFIGURATION CONTROL	1	09/01/14	B	EC 130 B4		X	B	TO REV. B
1-00-EC130	CONFIGURATION AND ADD OPTIONS	1	09/01/14	B	EC 130 B4		X	B	TO REV. B
1-1-AS350	AIR CONDITIONING OVERVIEW	1	09/01/14	G	CORPORATE VERSION	X		B	TO REV. G
1-2-AS350	AIR CONDITIONING OVERVIEW	1	09/01/14	D	EMS-2 VERSION	X		B	TO REV. D
1-3-AS350	AIR CONDITIONING OVERVIEW	1	01/19/22	F	ECL TOUR-2 VERSION	X		B	TO REV. F
1-4-AS350	AIR CONDITIONING OVERVIEW	1	09/01/14	D	ECL TOUR-1 VERSION	X		B	TO REV. D
1-5-AS350	AIR CONDITIONING OVERVIEW	1	08/04/23	F	AFT MOUNTED CONDENSER	X		B	TO REV. F
1-6-AS350	AIR CONDITIONING OVERVIEW	1	09/01/14	B	LAW ENFORCEMENT	X		B	TO REV. B
1-7-AS350	AIR CONDITIONING OVERVIEW	1	01/19/22	C	ECL TOUR 1	X		B	TO REV. C
1-8-AS350	AIR CONDITIONING OVERVIEW	1	09/01/14	B	EMS 1	X		B	TO REV. B
1-1-EC130	AIR CONDITIONING OVERVIEW	1	09/01/14	B	EC130		X	B	TO REV. B
2-00-AS350	ELECTRICAL ROUTING	1	09/01/14	B	AS350	X		B	TO REV. B
2-1-AS350	ELECTRICAL ROUTING	1	09/01/14	F	SINGLE CONDENSER BLOWER	X		B	TO REV. F
2-2-AS350	ELECTRICAL ROUTING	1	09/01/14	D	EMS-2 VERSION	X		B	TO REV. D
2-3-AS350	ELECTRICAL ROUTING	1	01/19/22	E	SINGLE COND/ECL/TOUR	X		B	TO REV. E
2-4-AS350	ELECTRICAL ROUTING	1	01/19/22	E	DUAL AFT/ECL TOUR	X		B	TO REV. E
2-5-AS350	ELECTRICAL ROUTING	1	09/01/14	D	DUAL COND. BLOWER/AFT MOUNT	X		B	TO REV. C
2-6-AS350	ELECTRICAL ROUTING	1	09/01/14	C	DUAL COND/SIDE MOUNT	X		B	TO REV. C
2-8-AS350	ELECTRICAL ROUTING	1	09/01/14	C	CORP. TOUR 2, EMS AND LAW ENF.	X		B	TO REV. C
2-9-AS350	ELECTRICAL ROUTING	1	09/01/14	B	EMS/ LAW ENFORCEMENT	X		B	TO REV. B
2-10-AS350	ELECTRICAL ROUTING	1	09/01/14	B	EMS-1	X		B	TO REV. B
2-11-AS350	ELECTRICAL DIAGRAM	1	01/19/22	L	ADDED EMI-RFI FILTERS	X		B	TO REV. L
2-13-AS350	ELECTRICAL DIAGRAM	1	01/19/22	I	ADDED EMI-RFI FILTER	X		B	TO REV. I
2-14-AS350	ELECTRICAL DIAGRAM	1	01/19/22	E	AFT MOUNTED/ECL TOUR	X		B	TO REV. E
2-16-AS350	ELECTRICAL DIAGRAM	1	01/19/22	G	DUAL COND. BLOWER/AFT MOUNT	X		B	TO REV. G
2-19-AS350	ELECTRICAL ROUTING	1	01/19/22	D	ECL TOUR 2	X		B	TO REV. D
2-21-AS350	ELECTRICAL DIAGRAM	1	01/19/22	G	SINGLE COND BLOWER	X		B	TO REV. G
2-23-AS350	ELECTRICAL DIAGRAM	1	01/19/22	F	SINGLE COND/ECL TOUR 1	X		B	TO REV. F
2-24-AS350	ELECTRICAL DIAGRAM	1	01/19/22	E	DUAL AFT/ECL TOUR 1	X		B	TO REV. E
2-25-AS350	ELECTRICAL DIAGRAM	1	01/19/22	F	DUAL COND BLOWER	X		B	TO REV. F
2-29-AS350	ELECTRICAL ROUTING	1	01/19/22	C	ECL TOUR 2	X		B	TO REV. C
2-1-EC130	ELECTRICAL ROUTING	1	08/04/23	C	EC130		X	B	TO REV. C
2-3-EC130	ELECTRICAL DIAGRAM	1	09/01/14	B	EC130		X	B	TO REV. B
3-4-AS350	PLUMBING DIAGRAM	1	08/04/23	E	AFT EVAP/SIDE MOUNT	X		B	TO REV. E
3-5-AS350	PLUMBING DIAGRAM	1	08/04/23	D	ALT AFT EVAP/AFT MOUNT	X		B	TO REV. D
3-14-AS350	PLUMBING ROUTING	1	09/01/14	C	AFT EVAP/SIDE MOUNT	X		B	TO REV. C
3-15-AS350	PLUMBING DIAGRAM	1	09/01/14	C	ALT AFT EVAP/AFT MOUNT	X		B	TO REV. C
3-1-EC130	PLUMBING DIAGRAM	1	09/01/14	B	PLUMBING DIAGRAM		X	B	TO REV. B
3-2-EC130	PLUMBING ROUTING	1	09/01/14	B	PLUMBING DIAGRAM		X	B	TO REV. B
4-3-AS350	AFT EVAP INSTALL	2	08/04/23	F	AFT EVAPORATOR	X		B	TO REV. F
4-13-AS350	AFT EVAP INSTALL	1	08/04/23	D	AFT EVAPORATOR INSTALL	X		B	TO REV. D
4-21-AS350	FWD EVAP INSTALL	1	08/04/23	J	FWD EVAPORATOR INSTALL	X		B	TO REV. J
4-1-EC130	AFT EVAP INSTALL	2	08/04/23	D	AFT EVAPORATOR INSTALL		X	B	TO REV. D
4-2-EC130	AFT EVAP INSTALL	1	09/01/14	B	AFT EVAPORATOR INSTALL		X	B	TO REV. B
4-3-EC130	FWD EVAP INSTALL	2	09/01/14	B	FWD EVAPORATOR INSTALL		X	B	TO REV. B
4-4-EC130	FWD DRAIN HOSE INSTALL	1	09/01/14	A	FWD DRAIN HOSE INSTALL		X	B	TO REV. A
5-1-AS350	AIR DISTRIBUTION	1	09/01/14	E	CORPORATE	X		B	TO REV. E
5-2-AS350	AIR DISTRIBUTION	1	09/01/14	E	EMS 2	X		B	TO REV. E
5-4-AS350	AIR DISTRIBUTION	1	01/19/22	F	ECL TOUR VERSION	X		B	TO REV. F
5-5-AS350	AIR DISTRIBUTION	1	09/01/14	D	ECL TOUR 2	X		B	TO REV. D
5-6-AS350	AIR DISTRIBUTION	1	09/01/14	B	EMS-1	X		B	TO REV. B
5-9-AS350	AIR CONDITIONING OVERVIEW	1	09/01/14	E	LAW ENFORCEMENT	X		B	TO REV. E
5-10-AS350	AIR CONDITIONING OVERVIEW	1	08/04/23	H	EMS-1	X		B	TO REV. H
5-11-AS350	AIR DISTRIBUTION	1	09/01/14	E	EMS-2/LAW ENFORCEMENT	X		B	TO REV. E



DRAWING NUMBER	DRAWING TITLE	# OF PAGES	DRAWING DATE	REVISION	DESCRIPTION	AS 350	EC130B4	SIZE	NEW/RVSD
5-12-AS350	AIR DISTRIBUTION	1	09/01/14	E	MULTIPLE	X		B	TO REV. E
5-21-AS350	AIR DISTRIBUTION	1	08/04/23	H	EMS/ LAW ENFORCEMENT	X		B	TO REV. H
5-22-AS350	AIR DISTRIBUTION	1	09/01/14	C	ECL TOUR	X		B	TO REV. C
5-24-AS350	AIR DISTRIBUTION	1	09/01/14	B	LAW ENFORCEMENT	X		B	TO REV. B
5-25-AS350	AIR DISTRIBUTION	1	09/01/14	B	ECL TOUR 1	X		B	TO REV. B
5-26-AS350	AIR DISTRIBUTION	1	08/04/23	C	AEC BASIC CONFIGURATION	X		B	TO REV. C
5-1-EC130	AIR DISTRIBUTION	1	01/19/22	D	EC130		X	B	TO REV. D
5-2-EC130	AIR DISTRIBUTION	1	09/01/14	B	EC130		X	B	TO REV. B
5-3-EC130	AIR DISTRIBUTION	1	09/01/14	C	EC130		X	B	TO REV. C
5-4-EC130	A/C INSTURMENTATION CONFIGURATIONS	1	01/19/22	C	EC 130 B4		X	B	TO REV. C
6-2-AS350	COMPRESSOR INSTALL	1	01/19/22	G	HP COMPRESSOR	X		B	TO REV. G
6-3-AS350	COMPRESSOR INSTALL	1	08/04/23	F	HP COMPRESSOR NEWER B3,B4	X		B	TO REV. F
6-12-AS350	COMPRESSOR INSTALL	1	09/01/14	E	HP COMPRESSOR	X		B	TO REV. E
6-13-AS350	COMPRESSOR INSTALL	1	09/01/14	C	HP COMPRESSOR NEWER B3,B4	X	X	B	TO REV. C
6-21-AS350	COMPRESSOR INSTALL	1	09/01/14	E	BRACKET INSTALLATION	X		B	TO REV. E
6-22-AS350	COMPRESSOR INSTALL	1	09/01/14	C	HP COMPRESSOR NEWER B3,B4	X	X	B	TO REV. C
6-1-EC130	COMPRESSOR INSTALLATION	1	01/19/22	D	COMPRESSOR INSTALLATION		X	B	TO REV. D
6-2-EC130	COMPRESSOR INSTALLATION	1	09/01/14	B	COMPRESSOR INSTALLATION		X	B	TO REV. B
6-3-EC130	COMPRESSOR INSTALLATION	1	09/01/14	B	COMPRESSOR INSTALLATION		X	B	TO REV. B
6-5-EC130	BELT TENSION	1	09/01/14	B	EC 130 B4		X	B	TO REV. B
7-2-AS350	CONDENSER INSTALL	2	01/19/22	I	ADDED BLOWERS	X		B	TO REV. I
7-11-AS350	CONDENSER INSTALL	1	09/01/14	D	RIGHT SIDE BAGGAGE	X		B	TO REV. D
7-22-AS350	CONDENSER INSTALL	1	08/04/23	F	AFT CONDENSER INSTALL	X		B	TO REV. F
7-23-AS350	LH AIR EXIT DOUBLER INSTALL	1	08/04/23	F	AFT MOUNTED CONDENSER	X		B	TO REV. F
7-24-AS350	RH AIR EXIT DOUBLER INSTALL	1	08/04/23	F	AFT MOUNTED CONDENSER	X		B	TO REV. F
7-25-AS350	INSTALL AIR INLET DOUBLER LH	1	01/19/22	E	AFT MOUNTED CONDENSER	X		B	TO REV. E
7-26-AS350	INSTALL AIR INLET DOUBLER RH	1	09/01/14	D	AFT MOUNTED CONDENSER	X		B	TO REV. D
7-28-AS350	R.H. AIR EXIT DOUBLER INSTALL	1	08/04/23	C	AFT MOUNTED CONDENSER	X		B	TO REV. C
7-29-AS350	L.H. AIR EXIT DOUBLER INSTALL	1	08/04/23	C	AFT MOUNTED CONDENSER	X		B	TO REV. C
7-1-EC130	AFT CONDENSER INSTALLATION	1	09/01/14	B	AFT CONDENSER INSTALL		X	B	TO REV. B
7-2-EC130	AFT CONDENSER EXHAUST INSTALLATION	1	09/01/14	B	AFT CONDENSER INSTALL		X	B	TO REV. B
7-3-EC130	INSTALLATION AIR INLET DOUBLER	1	09/01/14	B	AIR INLET DOUBLER		X	B	TO REV. B
8-2-AS350	BAGGAGE COMPARTMENT MOD.	1 OF 2	08/0423	H	AIR INTAKE	X		B	TO REV. H
8-2-AS350	BAGGAGE COMPARTMENT MOD.	2 OF 2	08/04/23	G	AIR INTAKE	X		B	TO REV. G
8-11-AS350	BAGGAGE COMPARTMENT MOD.	1	01/19/22	F	EMS/ LAW ENFORCEMENT	X		B	TO REV. F
8-1-EC130	ELECTRIC BOX SHELF	1	09/01/14	C	EC130		X	B	TO REV. C
8-2-EC130	ELECT. BOX VERTICAL INSTALLATION	1	09/01/14	B	AS 350, EC 130 B4	X	X	B	TO REV. B
MANUFACTURE DRAWINGS									
020011-"O"	CONDENSOR COIL	1	09/01/14	D			X	B	TO REV. D
020024-"O"-1	CONDENSOR COIL	1	08/04/23	G		X		B	TO REV. G
020027-"O"-4	EVAPORATOR COIL	1	01/19/22	F		X	X	B	TO REV. F
020031-"O"-1	EVAPORATOR COIL	1	01/19/22	D		X	X	B	TO REV. D
020044-"O"	CONDENSOR COIL	1	08/04/23	E		X		B	TO REV. E
030011	LOUVER (MOD)	1	09/01/14	B		X		B	TO REV. B
030021-1	PLASTIC WEMAC, BLACK	1	01/19/22	C		X		B	TO REV. C
030021-2	WEMAC MODIFIED	1	09/01/14	C		X		B	TO REV. C
040001-1	BLOWER HOUSING	1	08/04/23	E		X		B	TO REV. E
040002-1	MOTOR COVER PLATE	1	09/01/14	D		X		B	TO REV. D
040002-4	BLOWER COVER MODIFICATION	1	09/01/14	C		X		B	TO REV. C
040003	VENTURI RING	1	01/19/22	E		X		B	TO REV. E
040003-1	VENTURI RING	1	09/01/14	D		X		B	TO REV. D
050007-1	SWITCH BUTTON "A/C-OFF-FAN"	1	09/01/14	C		X	X	B	TO REV. C
050007-3	SWITCH BUTTON	1	09/01/14	C		X	X	B	TO REV. C

RSG PRODUCTS INC.
 440 West Ln
 Suite 100
 Saginaw TX 76131



Drawing List DL-9 Rev V
 August 04, 2023

DRAWING NUMBER	DRAWING TITLE	# OF PAGES	DRAWING DATE	REVISION	DESCRIPTION	AS 350	EC130B4	SIZE	NEW/RVSD
050007-4	SWITCH BUTTON	1	09/01/14	C		X	X	B	TO REV. C
050052-1	BLOWER MOTOR MODIFIED, RH	1	08/04/23	D		X		B	TO REV. D
050084-6	7" VANE AXIAL BLOWER ASSEMBLY	3	09/01/14	E		X	X	B	TO REV. E
050143	5" VANE AXIAL BLOWER ASSEMBLY	1	09/01/14	C		X	X	B	TO REV. C
050145	MOTOR 28 VDC	1	09/01/14	B		X	X	B	TO REV. B
070069	STANDOFF	1	09/01/14	B		X	X	B	TO REV. B
080007	EVAPORATOR COVER SCREEN	1	09/01/14	C			X	B	TO REV. C
080008	FRESH AIR SCREEN	1	09/01/14	A			X	B	TO REV. A
080010	AFT RETURN AIR SCREEN	1	09/01/14	D			X	B	TO REV. D
080011	CONDENSER EXHAUST SCREEN	1	09/01/14	B			X	B	TO REV. B
080012	CONDENSER COVER SCREEN	1	09/01/14	B			X	B	TO REV. B
080020	SCREEN, CONDENSER INLET	1	09/01/14	D		X		B	TO REV. D
080021	SCREEN, CONDENSER EXHAUST	1	09/01/14	E		X		B	TO REV. E
080022	RETURN AIR SCREEN	1	09/01/14	E		X		B	TO REV. E
080022-1	RETURN AIR SCREEN	1	08/04/23	F		X		B	TO REV. F
080024	RETURN AIR SCREEN FWD. EVAP	1	09/01/14	E		X		B	TO REV. E
080035	SCREEN, CONDENSER INLET	1	09/01/14	D		X		B	TO REV. D
080039	AIR OUTLET SCREEN	1	09/01/14	D		X		B	TO REV. D
080040	AIR INLET SCREEN	1	09/01/14	E		X		B	TO REV. E
110008	AFT RETURN AIR SCREEN DOUBLER	1	09/01/14	A			X	B	TO REV. A
110009	SERVO COVER (FRESH AIR)	1	09/01/14	B			X	B	TO REV. B
110010	CONDENSER COVER	1	09/01/14	A			X	B	TO REV. A
110011	INNER EXHAUST RING CONDENSER	1	01/19/22	C			X	B	TO REV. C
110012	OUTER EXHAUST RING CONDENSER	1	01/19/22	C			X	B	TO REV. C
110013	NIPPLE (FRESH AIR)	1	09/01/14	A			X	B	TO REV. A
110015	RETURN AIR DUCT	1	08/04/23	D			X	B	TO REV. D
110016	AIR OUTLET ADAPTER LOWER	1	09/01/14	A			X	B	TO REV. A
110017	AIR OUTLET ADAPTER UPPER	1	09/01/14	A			X	B	TO REV. A
110018	INNER CLOSEOUT SKIRT	1	01/19/22	B			X	B	TO REV. B
110019	OUTER CLOSEOUT SKIRT	1	01/19/22	B			X	B	TO REV. B
120019	PLACARD, SWITCH	2	09/01/14	F		X		B	TO REV. F
120019-1	PLACARD AFT CABIN	1	09/01/14	F		X		B	TO REV. F
120020	PLACARD DUAL ROCKER SWITCH	1	09/01/14	B		X		B	TO REV. B
120021	PLACARD	1	09/01/14	E		X		B	TO REV. E
120024	PLACARD, AC MASTER	1	09/01/14	F		X		B	TO REV. F
120025	CIRCUIT BREAKER PLACARD	1	09/01/14	C		X		B	TO REV. C
120085-1	A/C MASTER PLACARD	1	09/01/14	A		X		B	TO REV. A
120087	BATTERY COVER DECAL	1	09/01/14	C		X		B	TO REV. C
120104	AIR DUCT CLOSURE DECAL	1	09/01/14	C		X		B	TO REV. C
120105	SWITCH PLACARD	1	09/01/14	C		X		B	TO REV. C
120105-1	SWITCH PLACARD	1	09/01/14	B		X	X	B	TO REV. B
120106	PLACARD, CIRCUIT BREAKER	1	09/01/14	C		X	X	B	TO REV. C
120106-1	PLACARD, CIRCUIT BREAKER	1	09/01/14	A			X	B	TO REV. A
120107	PLACARD, CIRCUIT BREAKER	1	09/01/14	E		X		B	TO REV. E
120117	REFRIGERANT LABEL	1	08/04/23	D		X	X	B	TO REV. D
120152	A/C MASTER PLACARD	1	09/01/14	A			X	B	TO REV. A
120214	FREON SERVICING STICKER	1	09/01/14	A		X	X	B	TO REV. A
250022	FWD. LOUVER HOUSING R.H. OUTER	1	09/01/14	E		X		B	TO REV. E
250022-1	FWD. LOUVER HOUSING R.H. INNER	1	01/19/22	F		X		B	TO REV. F
250022-2	FWD. LOUVER HOUSING R.H. INNER	1	09/01/14	D		X		B	TO REV. D
250036	FWD. LOUVER HOUSING L.H. OUTER	1	09/01/14	D		X		B	TO REV. D
250037	FWD. LOUVER HOUSING L.H. INNER	1	09/01/14	D		X		B	TO REV. D
250148	SPACER, AIR DUCT CLOSURE CHANNEL	1	09/01/14	D		X		B	TO REV. D
250148-1	SPACER AIR DUCT CLOSURE CHANNEL	1	09/01/14	D		X		B	TO REV. D



DRAWING NUMBER	DRAWING TITLE	# OF PAGES	DRAWING DATE	REVISION	DESCRIPTION	AS 350	EC130B4	SIZE	NEW/RVSD
250149	RETURN AIR DUCT	1	09/01/14	E		X		B	TO REV. E
250157	FWD. EVAPORATOR WYE INNER	1	09/01/14	E		X		B	TO REV. E
250158	FWD. EVAPORATOR WYE OUTER	1	09/01/14	D		X		B	TO REV. D
250160	AFT EVAPORATOR FAN ELBOW, INNER	1	09/01/14	B		X		B	TO REV. B
250161	AFT EVAPORATOR FAN ELBOW, OUTER	1	09/01/14	B		X		B	TO REV. B
250164	ELECTRIACL BOX COVER	1	09/01/14	G		X	X	B	TO REV. G
250165	AFT EVAP. HOUSING	1	09/01/14	C		X		B	TO REV. C
250165-1	AFT EVAP. HOUSING	1	09/01/14	C		X	X	B	TO REV. C
250166	RETURN AIR CONNECTOR	1	08/04/23	J		X		B	TO REV. J
250168	MOTOR SHROUD	1	09/01/14	F		X		B	TO REV. F
250168-1	MOTOR SHROUD	1	09/01/14	E		X		B	TO REV. E
250174	FWD. EVAP. ENCLOSURE	1	01/19/22	G		X		B	TO REV. G
250175	AFT EVAP HOUSING DRAIN	1	01/19/22	H		X	X	B	TO REV. H
250176-1	FWD.EVAP. FWD. ENCLOSURE	1	08/04/23	F		X		B	TO REV. F
250176-2	FEW. EVAP. REMOVABLE COVER	1	09/01/14	C		X		B	TO REV. C
250188	CONDENSER COVER, FORWARD	1	09/01/14	C		X		B	TO REV. C
250188-1	CONDENSER HOUSING CLOSEOUT	1	09/01/14	A		X		B	TO REV. A
250239-1	SCREEN RETAINER COND. EXHAUST	1	09/01/14	B		X		B	TO REV. B
250239-2	SCREEN RETAINER COND. EXHAUST	1	09/01/14	C		X		B	TO REV. C
250254	AIR TUBE	1	09/01/14	C		X		B	TO REV. C
250254-1	AIR TUBE	1	09/01/14	C		X		B	TO REV. C
250269	COND. HOUSING	1	01/19/22	F		X		B	TO REV. F
250272	AFT EVAP. ELBOW / INNER	1	09/01/14	E		X		B	TO REV. E
250273	AFT EVAP. ELBOW / OUTER	1	09/01/14	E		X		B	TO REV. E
250292	CONDENSER AIR INTAKE	1	01/19/22	D		X		B	TO REV. D
250299	VENT ADAPTER	1	09/01/14	E		X		B	TO REV. E
250301	AFT BAGGAGE CLOSEOUT PANEL	1	09/01/14	B		X		B	TO REV. B
250311	EVAP. MOTOR SHIM PLATE	1	09/01/14	B		X		B	TO REV. B
250314	INNER COVER	1	01/19/22	C		X		B	TO REV. C
250316-1	AIR OUTLET HOUSING, R.H.	1	09/01/14	C		X		B	TO REV. C
250319-1	AIR TUBE	1	09/01/14	C		X	X	B	TO REV. C
250324	AIR EXIT COLLAR	1	09/01/14	B		X		B	TO REV. B
250355	AFT EVAP HOUSING	1	09/01/14	E			X	B	TO REV. E
250370	FILLER	1	09/01/14	D		X	X	B	TO REV. D
250393	FWD EVAPORATOR ENCLOSURE	1	09/01/14	A			X	B	TO REV. A
250394	REMOVABLE COVER	1	08/04/23	B			X	B	TO REV. B
250402	AFT TRANSITION ELBOW	1	08/04/23	G		X		B	TO REV. G
250408	RIGHT HAND AIR TUBE	1	09/01/14	C		X		B	TO REV. C
250409	LEFT HAND AIR TUBE	1	09/01/14	B		X		B	TO REV. B
250431	AIR TUBE	1	09/01/14	B		X		B	TO REV. B
250440	AIR DISTRIBUTION MANIFOLD NOZZLE FWD	1	09/01/14	B			X	B	TO REV. B
250441	AIR DISTRIBUTION MANIFOLD LOWER	1	09/01/14	A			X	B	TO REV. A
250442	AIR DISTRIBUTION MANIFOLD UPPER	1	09/01/14	A			X	B	TO REV. A
250443	AIR DISTRIBUTION MANIFOLD NOZZLE, REAR	1	09/01/14	B			X	B	TO REV. B
250444	CONDENSER EXHAUST TUBE	1	09/01/14	A			X	B	TO REV. A
250445	AIR OUTLET LEFT SIDE	1	09/01/14	B			X	B	TO REV. B
250446	AIR OULET RIGHT SIDE	1	09/01/14	B			X	B	TO REV. B
250447	AIR OUTLET LEFT SIDE	1	09/01/14	A			X	B	TO REV. A
250448	AIR OUTLET MOUNT RIGHT SIDE	1	09/01/14	A			X	B	TO REV. A
250449	FWD EVAPORATOR HOUSING ASSY	1	09/01/14	B			X	B	TO REV. B
250450	EVAP COVER ASSEMBLY ENCLOSURE	1	09/01/14	A			X	B	TO REV. A
250458	AIR DISTRIBUTION BAFFLE	1	09/01/14	A			X	B	TO REV. A
260002	COND. MTG. ANGLE	1	09/01/14	D		X		B	TO REV. D
260004	COND. MTG. SUPPORT FWD	1	09/01/14	D		X		B	TO REV. D



DRAWING NUMBER	DRAWING TITLE	# OF PAGES	DRAWING DATE	REVISION	DESCRIPTION	AS 350	EC130B4	SIZE	NEW/RVSD
260005	COND. MTG. SUPPORT SPACER	1	08/04/23	F		X		B	TO REV. F
260006	COND. MTG. SUPPORT SPACER	1	01/19/22	E		X		B	TO REV. E
260007	COND. MOUNTING SUPPORT AFT	1	09/01/14	F		X		B	TO REV. F
260008	COND. MTG. SUPPORT SPACER	1	09/01/14	D		X		B	TO REV. D
260009	COND. MTG. SUPPORT SPACER	1	08/04/23	G		X		B	TO REV. G
260020	FAN CHANNEL BASE ANGLE	1	09/01/14	D		X		B	TO REV. D
260123-2	MOUNT RECEIVER / DRIER	2	08/04/23	D		X	X	B	TO REV. D
260148	CONDENSER FAN MOUNT	1	08/04/23	E		X		B	TO REV. E
260148-3	CONDENSER FAN MOUNT	1	08/04/23	D		X		B	TO REV. D
260216	AIR DUCT CLOSURE CHANNEL	1	09/01/14	F		X		B	TO REV. F
260234	AIR DUCT CLOSURE INSERT	1	09/01/14	E		X		B	TO REV. E
260321	CONDENSER FAN MOUNT RING	1	09/01/14	E		X		B	TO REV. E
260322	DOUBLER, RETURN AIR	1	08/04/23	D		X		B	TO REV. D
260322-1	DOUBLER, RETURN AIR	1	08/04/23	F		X		B	TO REV. F
260322-2	ANGLE	1	08/04/23	F		X		B	TO REV. F
260325	AFT. EVAP. CLOSEOUT, FWD.	1	08/04/23	F		X	X	B	TO REV. F
260325-1	AFT. EVAP. CLOSEOUT, FWD.	1	08/04/23	B		X	X	B	TO REV. B
260326	EVAP. CLOSEOUT, AFT.	1	08/04/23	F		X	X	B	TO REV. F
260327	AFT EVAP. CLOSEOUT INBOARD	1	08/04/23	F		X	X	B	TO REV. F
260327-1	AFT EVAP. CLOSEOUT OUTBOARD	1	08/04/23	F		X	X	B	TO REV. F
260328-1	AFT EVAP. FAN DOUBLER	1	08/04/23	F		X		B	TO REV. F
260333	BATTERY COMP. SHELF	1	09/01/14	F		X		B	TO REV. F
260335	BATTERY COMPARTMENT SHELF ANGLE FWD	1	09/01/14	E		X		B	TO REV. E
260339	ANGLE BATTERY COVER	1	08/04/23	E		X		B	TO REV. E
260343	ELECTRICAL BOX BODY	1	08/04/23	E		X		B	TO REV. E
260343-1	ELECTRICAL BOX BODY	1	08/04/23	E		X	X	B	TO REV. E
260344	ELECTRICAL BOX SHIM	1	08/04/23	E		X	X	B	TO REV. E
260344-1	ELEC. BOX ANGLE	1	08/04/23	E		X	X	B	TO REV. E
260350	UPPER CLOSEOUT, AFT EVAPORATOR	1	08/04/23	F		X	X	B	TO REV. F
260351	AFT SWITCH BACKING PLATE	1	08/04/23	F		X		B	TO REV. F
260354	ANGLE, RETURN AIR CONNECTOR	1	08/04/23	F		X		B	TO REV. F
260369	HOSE DOUBLER, BAG COMP.	1	09/01/14	G		X		B	TO REV. G
260372	FWD. EVAP. ANGLE	1	09/01/14	D		X		B	TO REV. D
260373	DOUBLER	1	08/04/23	E		X		B	TO REV. E
260373-1	DOUBLER	1	08/04/23	G		X	X	B	TO REV. G
260486-1	FWD EVAP SUPPORT VERTICAL	1	09/01/14	C			X	B	TO REV. C
260862	FILLER	1	08/04/23	D		X		B	TO REV. D
260863	FWD. EVAP. MOUNT	1	08/04/23	E		X		B	TO REV. E
260863-1	FWD. EVAP. MOUNT	1	08/04/23	C		X		B	TO REV. C
260915	RING	1	08/04/23	D			X	B	TO REV. D
260947	TURNING VANE	1	08/04/23	D		X		B	TO REV. D
260951	ANGLE	1	01/19/22	D		X		B	TO REV. D
260951-1	ANGLE	1	01/19/22	D		X		B	TO REV. D
260952	CLIP	1	08/04/23	D		X		B	TO REV. D
260953	CLIP	1	08/04/23	D		X		B	TO REV. D
261006	ANGLE	1	09/01/14	C		X		B	TO REV. C
261006-1	ANGLE R.H. LOWER WEMAC MOUNT	1	09/01/14	B		X		B	TO REV. B
261006-2	ANGLE	1	09/01/14	B		X		B	TO REV. B
261006-3	ANGLE	1	08/04/23	B		X		B	TO REV. B
261007	BUSHING, SD-507	1	01/19/22	E		X	X	B	TO REV. E
261008	BUSHING, SD-507	1	08/04/23	F		X	X	B	TO REV. F
261012	STRINGER, OUTBOARD	1	08/04/23	C		X		B	TO REV. C
261013	L/H AIR INLET DOUBLER	1	08/04/23	D		X		B	TO REV. D
261013-2	R/H AIR INLET DOUBLER	1	08/04/23	C		X		B	TO REV. C



DRAWING NUMBER	DRAWING TITLE	# OF PAGES	DRAWING DATE	REVISION	DESCRIPTION	AS 350	EC130B4	SIZE	NEW/RVSD
261014	STRAP	1	08/04/23	C		X		B	TO REV. C
261071	CLOSEOUT PANEL	1	08/04/23	E		X		B	TO REV. E
261072	CLOSEOUT PANEL DOUBLER	1	08/04/23	E		X	X	B	TO REV. E
261074	PLATE, BACK	1	08/04/23	D		X		B	TO REV. D
261075	CLOSEOUT, TOP/BOTTOM	1	08/04/23	C		X		B	TO REV. C
261076	FILLER	1	08/04/23	D		X		B	TO REV. D
261077	ANGLE CLOSEOUT	1	08/04/23	D		X		B	TO REV. D
261078	CLOSEOUT, SIDE	1	08/04/23	C		X		B	TO REV. C
261079	MOTOR MOUNT	1	08/04/23	E		X		B	TO REV. E
261080	CHANNEL, SUPPORT, FORWARD	1	08/04/23	C		X		B	TO REV. C
261081	CHANNEL, SUPPORT, AFT	1	08/04/23	C		X		B	TO REV. C
261082	ANGLE	1	08/04/23	C		X		B	TO REV. C
261083	BAFFLE	1	08/04/23	C		X		B	TO REV. C
261086-1	SWITCH PLATE	1	09/01/14	B		X	X	B	TO REV. B
261086-2	SWITCH PLATE	1	09/01/14	D		X		B	TO REV. D
261087	ANGLE	1	08/04/23	C		X		B	TO REV. C
261089-1	WEMAC MOUNT	1	08/04/23	D		X		B	TO REV. D
261094	FILLER STRIP UPPER	1	08/04/23	C		X		B	TO REV. C
261095	FILLER STRIP LOWER	1	08/04/23	C		X		B	TO REV. C
261096	ANGLE UPPER RH	1	08/04/23	D		X		B	TO REV. D
261097	ANGLE UPPER LH	1	08/04/23	D		X		B	TO REV. D
261098	ANGLE LOWER RH	1	08/04/23	D		X		B	TO REV. D
261099	ANGLE LOWER LH	1	08/04/23	D		X		B	TO REV. D
261100	RH AIR EXIT DOUBLER	1	08/04/23	D		X		B	TO REV. D
261100-1	RH AIR EXIT DOUBLER	2	08/04/23	B		X		B	TO REV. B
261101	LH AIR EXIT DOUBLER	1	08/04/23	D		X		B	TO REV. D
261101-1	LH AIR EXIT DOUBLER	2	08/04/23	B		X		B	TO REV. B
261107	RELAY STRAP	1	08/04/23	D		X	X	B	TO REV. D
261107-2	RELAY STRAP	1	09/01/14	A			X	B	TO REV. A
261176	FAN BLADE HUB	1	09/01/14	C		X	X	B	TO REV. C
261299	TRANSITION ELBOW STRAP	1	08/04/23	E		X		B	TO REV. E
261333HP	VENT HOUSING	2	08/04/23	B		X			TO REV. B
261335HP	VENT MOUNT	1	09/01/14	NC		X			TO REV. NC
261336HP	BACK PLATE	1	09/01/14	NC		X			TO REV. NC
261346HP	MOUNTING PLATE	1	09/01/14	NC		X			TO REV. NC
261347HP	RELAY BRACKET	1	09/01/14	NC		X			TO REV. NC
261348HP	DZUS RAIL, SWITCH ASSEMBLY	1	09/01/14	NC		X			TO REV. NC
261351	CLIP (FRESH AIR DOOR)	1	09/01/14	B			X	B	TO REV. B
261352	HINGE DOOR	1	09/01/14	C			X	B	TO REV. C
261353	SERVO MOUNT	1	09/01/14	B			X	B	TO REV. B
261354	DOOR	1	09/01/14	B			X	B	TO REV. B
261355	FWD EVAP SUPPORT LOWER	1	01/19/22	B			X	B	TO REV. B
261356	FWD EVAP SUPPORT UPPER	1	01/19/22	B			X	B	TO REV. B
261357	FWD EVAP MOUNT SHIM	1	09/01/14	B			X	B	TO REV. B
261358	NUT PLATE STRIP FORWARD EVAPORATOR	1	09/01/14	A			X	B	TO REV. A
261359	DOOR HANDLE	1	09/01/14	B			X	B	TO REV. B
261360	FWD BRACE CONDENSER	1	09/01/14	A			X	B	TO REV. A
261361	AFT BRACE CONDENSER	1	08/04/23	C			X	B	TO REV. C
261362	MOUNT PLATE	1	09/01/14	A			X	B	TO REV. A
261363	FWD EVAP MOUNT PLATE	1	08/04/23	B			X	B	TO REV. B
261364	CONDENSER MOUNT LEFT & RIGHT	1	09/01/14	A			X	B	TO REV. A
261365	SERVO MOUNT PLATE	1	09/01/14	B			X	B	TO REV. B
261366	CONDENSER BODY	1	09/01/14	A			X	B	TO REV. A
261367	CONDENSER ANGLE LEFT	1	08/04/23	C			X	B	TO REV. C



DRAWING NUMBER	DRAWING TITLE	# OF PAGES	DRAWING DATE	REVISION	DESCRIPTION	AS 350	EC130B4	SIZE	NEW/RVSD
261367-1	CONDENSER ANGLE RIGHT	1	08/04/23	B			X	B	TO REV. B
261368	AFT MANIFOLD BRACKET	1	09/01/14	B			X	B	TO REV. B
261369	AIR VALVE BODY	1	08/04/23	C			X	B	TO REV. C
261370	R.H. FAN DOUBLER	1	09/01/14	B			X	B	TO REV. B
261371	R.H. FAN DOUBLER SHIM	1	09/01/14	B			X	B	TO REV. B
261374	AFT MANIFOLD BRACKET BASE	1	09/01/14	A			X	B	TO REV. A
261375	ELECTRICAL BOX SHELF	1	09/01/14	B			X	B	TO REV. B
261377	AC MASTER PLATE	1	09/01/14	A			X	B	TO REV. A
261511	L.H. STRAP	1	08/04/23	B		X		B	TO REV. B
261512	R.H. STRAP	1	08/04/23	B		X		B	TO REV. B
261513	FILLER	1	08/04/23	B		X		B	TO REV. B
261585	RESISTOR MOUNT	1	09/01/14	A		X	X	B	TO REV. A
300066	PULLEY MODIFIED	1	09/01/14	C		X		B	TO REV. C
300066-1	PULLEY MODIFIED	1	09/01/14	A		X		B	TO REV. A
300067	COMPRESSOR STAND OFF	1	01/19/22	G		X		B	TO REV. G
300067-1	COMPRESSOR STAND OFF	1	01/19/22	B		X	X	B	TO REV. B
300068-1	COMPRESSOR MOUNT, ARM	1	09/01/14	C		X		B	TO REV. C
300068-2	ARM, COMPRESSOR MOUNT	1	09/01/14	B		X	X	B	TO REV. B
300068-3	ARM COMPRESSOR MOUNT	1	09/01/14	D		X	X	B	TO REV. D
300069-1	ARM, COMP. MT.	1	09/01/14	C		X	X	B	TO REV. C
300069-2	ARM COMPRESSOR MOUNT	1	09/01/14	D		X	X	B	TO REV. D
300070-1	GUSSET	1	09/01/14	D		X	X	B	TO REV. D
300095	COMPRESSOR PIN	1	09/01/14	D		X	X	B	TO REV. D
300329	SPACER TUBE	1	09/01/14	E		X	X	B	TO REV. E
300355	PULLEY MODIFIED	1	09/01/14	D		X		B	TO REV. D
300355-2	PULLEY MODIFIED	1	08/04/23	F		X		B	TO REV. F
300363	COMPRESSOR HOUSING SUPPORT	1	09/01/14	D		X		B	TO REV. D
300363-1	COMP. HOUSING SUPPORT LOWER	1	09/01/14	A		X	X	B	TO REV. A
300363-2	COMPRESSOR SHIM UPPER	1	09/01/14	A		X	X	B	TO REV. A
300364	COMPRESSOR HOUSING BUSHING	1	01/19/22	D		X	X	B	TO REV. D
300396	5 GROOVE PULLEY	1	08/04/23	D			X	B	TO REV. D
490015	BLOWER HOUSING ASSY	1	09/01/14	C		X		B	TO REV. C
490015-1	BLOWER HOUSING ASSY	1	08/04/23	F		X		B	TO REV. F
490016-1	FWD. BLOWER ASSEMBLY	1	08/04/23	E		X		B	TO REV. E
490017-1	AFT EVAPORATOR FAN	1	08/04/23	G		X		B	TO REV. G
500001	LEFT SIDE AIR OUTLET ASSEMBLY	1	09/01/14	B			X	B	TO REV. B
500002	RIGHT SIDE AIR OUTLET ASSEMBLY	1	09/01/14	B			X	B	TO REV. B
500008-1	LOUVER ASSEMBLY, RH	1	09/01/14	E		X		B	TO REV. E
500010-1	LOUVER HOUSING ASSY. R.H.	1	09/01/14	F		X		B	TO REV. F
500011-1	LOUVER HOUSING ASSY. L.H.	1	09/01/14	F		X		B	TO REV. F
500018	AIR OUTLET ASSY, RH	1	01/19/22	E		X		B	TO REV. E
500018-1	AIR OUTLET ASSY, RH	1	01/19/22	D		X		B	TO REV. D
500018-2	AIR OUTLET ASSY, L/H	1	09/01/14	D		X		B	TO REV. D
500033	INNER COVER ASSEMBLY	1	09/01/14	B		X		B	TO REV. B
510007	AFT. CHANNEL COND. SUPPORT ASSEMBLY	1	08/04/23	E		X		B	TO REV. E
510008	FWD COND. CHANNEL ASSEMBLY	1	01/19/22	E		X		B	TO REV. E
510091	COND. FAN MOUNT RING ASSEMBLY	1	09/01/14	E		X		B	TO REV. E
510091-2	COND. FAN MOUNT RING ASSY	1	09/01/14	C		X	X	B	TO REV. C
510092	AIR DUCT CLOSURE ASSEMBLY	1	09/01/14	C		X		B	TO REV. C
510099	UPPER CLOSEOUT, AFT EVAPORATOR ASSY	1	09/01/14	D		X	X	B	TO REV. D
510200	BOX ASSY	1	09/01/14	D		X		B	TO REV. D
510200-1	BOX ASSY	1	09/01/14	C		X	X	B	TO REV. C
510233	RING ASSEMBLY	1	09/01/14	B			X	B	TO REV. B
510259	AIR OUTLET ASSEMBLY	1	09/01/14	D		X		B	TO REV. D



DRAWING NUMBER	DRAWING TITLE	# OF PAGES	DRAWING DATE	REVISION	DESCRIPTION	AS 350	EC130B4	SIZE	NEW/RVSD
510259-1	AIR OUTLET ASSEMBLY, LOWER	1	09/01/14	C		X		B	TO REV. C
510259-2	AIR OUTLET ASSEMBLY	1	09/01/14	C		X		B	TO REV. C
510259-3	AIR OUTLET ASSEMBLY	1	09/01/14	A		X		B	TO REV. A
510261	ANGLE RETURN AIR CONECTOR ASSY	1	09/01/14	C		X		B	TO REV. C
510265	BATTERY COMP. SHELF ANGLE FWD ASSY.	1	09/01/14	C		X		B	TO REV. C
510266	RETURN AIR DOUBLER ASSEMBLY	1	09/01/14	C		X		B	TO REV. C
510283	CLOSEOUT, BOTTOM ASSEMBLY	1	09/01/14	C		X		B	TO REV. C
510284	CLOSEOUT, SIDE ASSEMBLY	1	09/01/14	C		X		B	TO REV. C
510372	CLIP ASSEMBLY (FRESH AIR)	1	09/01/14	A			X	B	TO REV. A
510373	NUT PLATE STRIP ASSY FWD EVAP	1	09/01/14	A			X	B	TO REV. A
510374	SERVO MOUNT SHELF ASSY	1	08/04/23	C			X	B	TO REV. C
510375	SERVO MOUNT FRAME ASSEMBLY	1	09/01/14	A			X	B	TO REV. A
510376	ASSEMBLY (FRESH AIR DOOR)	1	08/04/23	C			X	B	TO REV. C
510377	FRESH AIR ASSY (METAL)	1	09/01/14	B			X	B	TO REV. B
510378HP	OVERLAY ASSEMBLY	1	09/01/14	NC		X			TO REV. NC
510379	FWD EVAP SUPPORT ASSY UPPER	1	09/01/14	A			X	B	TO REV. A
510380	FWD EVAP SUPPORT ASSY LOWER	1	09/01/14	A			X	B	TO REV. A
510381	MOUNT PLATE ASSEMBLY	1	01/19/22	B			X	B	TO REV. B
510384	ELECT BOX MOUNT ASSEMBLY	1	09/01/14	A		X	X	B	TO REV. A
510463	RESISTOR MOUNT ASSEMBLY	1	09/01/14	A		X	X	B	TO REV. A
520001	CONDENSER EXHAUST ASSEMBLY	1	09/01/14	A			X	B	TO REV. A
520002	AIR DISTRIBUTION MANIFOLD ASSY	1	08/04/23	D			X	B	TO REV. D
520003-130	AIR DIST. MANIFOLD ASSY COMP	1	09/01/14	C			X	B	TO REV. C
520004-130	CONDENSER ASSY	1	09/01/14	B			X	B	TO REV. B
520005	MANIFOLD NOZZLE ASSEMBLY	1	08/04/23	E			X	B	TO REV. E
520032-1	CONDENSER EXHAUST ELBOW	1	09/01/14	B		X		B	TO REV. B
520033	EVAPORATOR WYE ASSEMBLY	1	09/01/14	C		X		B	TO REV. C
520033-1	FWD EVAP WYE ASSY	1	08/04/23	D		X		B	TO REV. D
520034	AFT EVAPORATOR FAN ELBOW ASSY.	1	09/01/14	B		X		B	TO REV. B
520036-3	AFT TRANSITION ELBOW ASSEMBLY	1	08/04/23	E		X		B	TO REV. E
520052-1	SCREEN ASSEMBLY COND. EXHAUST	1	09/01/14	C		X		B	TO REV. C
520052-2	SCREEN ASSY- COND. EXHAUST	1	09/01/14	C		X		B	TO REV. C
520061	AFT EVAPORATOR FAN ELBOW ASSY.	1	09/01/14	D		X		B	TO REV. D
520071	CONDENSER AIR INTAKE ASSY	1	09/01/14	B		X		B	TO REV. B
520071-1	CONDENSER AIR INTAKE ASSY	1	08/04/23	D		X		B	TO REV. D
520073	FWD. EVAP. REMOVABLE COVER ASSY.	1	08/04/23	C		X		B	TO REV. C
520120	AIR OUTLET ADAPTER ASSEMBLY	1	09/01/14	B			X	B	TO REV. B
520156HP	AIR VENT ASSEMBLY L.H.	1	08/04/23	A		X			TO REV. A
520157HP	AIR VENT ASSEMBLY R.H.	1	09/01/14	NC		X			TO REV. NC
530027-1	SD-505 COMPRESSOR MOUNT ASSY	1	09/01/14	D		X		B	TO REV. D
530027-2	SD-505 COMPRESSOR MOUNT ASSY	1	09/01/14	B		X		B	TO REV. B
530027-3	COMPRESSOR MOUNT ASSY	1	09/01/14	F		X	X	B	TO REV. F
530084	VENTURI RING ASSY.	1	09/01/14	B		X		B	TO REV. B
530100	STRAP, HOUSING MOD ASSY	1	09/01/14	D		X		B	TO REV. D
530100-1	STRAP, HOUSING MOD ASSY	1	09/01/14	B		X	X	B	TO REV. B
540007	FRESH AIR INTAKE ASSEMBLY	2	08/04/23	E			X	B	TO REV. E
540008	FRESH AIR SERVO WIRING DIAGRAM	1	09/01/14	B			X	B	TO REV. B
540008-1	FRESH AIR SERVO CIRCUIT BOARD ASSY/DIAG	1	01/19/22	C			X	B	TO REV. C
540009	ELECTRICAL BOX ASSY	1	08/04/23	E			X	B	TO REV. E
540010	HARNESS ASSEMBLY	1	09/01/14	A			X	B	TO REV. A
540011	SWITCH ASSEMBLY	1	01/19/22	C			X	B	TO REV. C
540012	PANEL MOUNT SWITCH ASSEMBLY	1	09/01/14	A			X	B	TO REV. A
540020	RESISTOR ASSEMBLY	1	09/01/14	A		X	X	B	TO REV. A
540028-C	ELECTRICAL BOX ASSEMBLY	1	09/01/14	C		X		B	TO REV. C

RSG PRODUCTS INC.
 440 West Ln
 Suite 100
 Saginaw TX 76131



Drawing List DL-9 Rev V
 August 04, 2023

DRAWING NUMBER	DRAWING TITLE	# OF PAGES	DRAWING DATE	REVISION	DESCRIPTION	AS 350	EC130B4	SIZE	NEW/RVSD
540028-"C"-1	ELECTRICAL BOX ASSEMBLY	1	09/01/14	B		X		B	TO REV. B
540028-"C"-1-A	ELECTRICAL BOX ASSEMBLY	1	08/04/23	F		X		B	TO REV. F
540028-"C"-2	ELECTRICAL BOX ASSEMBLY	1	09/01/14	C		X		B	TO REV. C
540028-"C"-2-A	ELECTRICAL BOX ASSEMBLY	2	08/04/23	F		X		B	TO REV. F
540044	HARNESS ASSEMBLY	1	09/01/14	C		X		B	TO REV. C
540044-2	HARNESS ASSEMBLY	1	09/01/14	C		X		B	TO REV. C
540044-3	HARNESS ASSEMBLY	1	08/04/23	J		X		B	TO REV. J
540044-4	HARNESS ASSEMBLY	1	08/04/23	H		X		B	TO REV. H
540044-5	HARNESS ASSEMBLY	2	01/19/22	F		X		B	TO REV. F
540044-6	HARNESS ASSEMBLY	1	01/19/22	E		X		B	TO REV. E
540044-7	HARNESS ASSEMBLY	1	09/01/14	C		X		B	TO REV. C
540044-8	INSTRUMENT PANEL SWITCH	1	01/19/22	D		X		B	TO REV. D
540044-9	5 AMP CIRCUIT BREAKER ASSY	1	09/01/14	B		X		B	TO REV. B
540045-1	HARNESS ASSEMBLY	1	01/19/22	D		X	X	B	TO REV. D
540056	ELECT. BOX VERTICAL MOUNTING ASSY	1	09/01/14	A		X	X	B	TO REV. A
540089	AFT EVAPORATOR SWITCH ASSY	1	01/19/22	E		X		B	TO REV. E
550002-"O"	COND. COIL ASSY	1	09/01/14	E		X		B	TO REV. E
550002-"O"-1	COND. COIL ASSY	1	09/01/14	C		X		B	TO REV. C
550003-"O"	AFT CONDENSER ASSY	3	01/19/22	C			X	B	TO REV. C
550004-"O"	CONDENSER COIL ASSY	1	09/01/14	A			X	B	TO REV. A
550007-1	COND. ASSEMBLY	1	08/04/23	G		X		B	TO REV. G
550022	COND. ASSEMBLY	1	08/04/23	J		X		B	TO REV. J
560004	FORWARD EVAPORATOR ASSEMBLY	2	09/01/14	B			X	B	TO REV. B
560005	FWD EVAPORATOR COIL ASSEMBLY	1	08/04/23	C			X	B	TO REV. C
560006	FWD EVAP COIL HOUSING ASSY	1	01/19/22	C			X	B	TO REV. C
560010-"O"-5	AFT EVAPORATOR ASSEMBLY	1	08/04/23	F		X		B	TO REV. F
560012-"O"-3	AFT EVAPORATOR COIL ASSEMBLY	1	01/19/22	E		X	X	B	TO REV. E
560016-"O"	COIL ASSEMBLY FWD	1	09/01/14	B		X		B	TO REV. B
560016-"O"-1	AFT EVAPORATOR ASSEMBLY	1	08/04/23	D			X	B	TO REV. D
560025-"O"	FWD. EVAP. ASSY.	1	08/04/23	G		X		B	TO REV. G
560052-"O"	COIL ASSY FORWARD	1	01/19/22	E		X		B	TO REV. E
570020-"O"-A	HOSE ASSEMBLY, COND. TO REC/ DRIER	1	09/01/14	C		X		B	TO REV. C
570021-"O"-A	HOSE ASSY. FWD. EVAP. TO AFT EVAP	1	09/01/14	C		X		B	TO REV. C
570022-"O"-A	HOSE ASSY. EVAP. TO EVAP.	1	09/01/14	C		X		B	TO REV. C
570023-"O"-A	HOSE ASSEMBLY, COMP. SUCTION	1	09/01/14	C		X		B	TO REV. C
570024-"O"-A	HOSE ASSY, COMPRESSOR DISCHARGE	1	09/01/14	E		X		B	TO REV. E
570067-"O"-A	HOSE ASSY, COND TO REC/DRIER	1	09/01/14	D		X		B	TO REV. D
570070-"O"-A	HOSE ASSY, COMPRESSOR TO COND	1	09/01/14	D		X	X	B	TO REV. D
570071-"O"-A	HOSE ASSY, FWD EVAP. TO AFT EVAP.	1	09/01/14	B		X		B	TO REV. B
570072-"O"-A	HOSE ASSY, EVAP TO EVAP	1	01/19/22	E		X		B	TO REV. E
570087-"O"-A	HOSE ASS, FWD EVAP. TO AFT EVAP	1	01/19/22	F		X		B	TO REV. F
570103	HIGH PRESSURE HOSE, #6 ASSEMBLY	1	09/01/14	B			X	B	TO REV. B
570104	CONDENSER TO REC DRYER #6 ASSY	1	09/01/14	B			X	B	TO REV. B
570105	RETURN HOSE #10 ASSEMBLY	1	09/01/14	B			X	B	TO REV. B
580000	5" HUB & PROPELLER ASSY	1	09/01/14	C		X		B	TO REV. C
590001-1-"O"	SD-505 COMPRESSOR ASSEMBLY	1	09/01/14	C		X		B	TO REV. C
590008	COMPRESSOR ASSEMBLY	1	08/04/23	E		X	X	B	TO REV. E
590008-1	COMPRESSOR ASSEMBLY	1	08/04/23	D		X	X	B	TO REV. D
590010	MOTOR 28 VDC MODIFIED	1	09/01/14	D		X		B	TO REV. D
600002	FRESH AIR ASSMBLY	1	01/19/22	C			X	B	TO REV. C
04-130-21-101	COMPRESSOR MOUNT BRACKET	1	05/18/12	A		X	X	B	TO REV. A
04-130-21-102	COMPRESSOR MOUNT TENSION BOLT	1	01/19/22	A		X	X	B	TO REV. A
04-130-21-104	JAM NUT, DRILLED	1	04/30/12	NC		X	X	B	TO REV. NC
04-130-21-105	COMPRESSOR CLAMP	1	04/30/12	NC		X	X	B	TO REV. NC

RSG PRODUCTS INC.
 440 West Ln
 Suite 100
 Saginaw TX 76131



Drawing List DL-9 Rev V
 August 04, 2023

DRAWING NUMBER	DRAWING TITLE	# OF PAGES	DRAWING DATE	REVISION	DESCRIPTION	AS 350	EC130B4	SIZE	NEW/RVSD
04-130-21-107	HOSE DISCONNECT BRACKET	1	04/30/12	NC		X	X	B	TO REV. NC
IFSS 050084-7-2	7" DC BRUSHLESS BLOWER ASSEMBLY	1	01/19/22	E		X	X	B	TO REV. E
IFSS 050084-7-3	7" DC BRUSHLESS BLOWER ASSEMBLY	1	01/19/22	E		X	X	B	TO REV. E
IFSS 261323	3-PIN CONNECTOR W/COLLAR ASSY	1	01/19/22	C		X	X	B	TO REV. C
IFSS 540126-1	CONTROLLER ASSEMBLY	1	01/19/22	C		X	X	B	TO REV. C
IFSS 261319	CURVED BASE MOUNT	1	01/19/22	B		X	X	B	TO REV. B
IFSS 261314-1	CURVED BASE MOUNT ASSY	1	01/19/22	B		X	X	B	TO REV. B
IFSS 040021	7" BLOWER HOUSING, STEEL	1	01/19/22	C		X	X	B	TO REV. C
IFSS 050193	MOOG DC BRUSHLESS MOTOR	3	01/19/22	B		X	X	B	TO REV. B
IFSS 040020	7" HOUSING, SINGLE FLANGE WITH BEAD, STEEL	1	08/04/23	D		X	X	B	TO REV. D
IFSS 040019	7" PROPELLER - MOOG	1	01/19/22	B		X	X	B	TO REV. B
IFSS 050176-1	7" PROPELLER HUB	1	01/19/22	B		X	X	B	TO REV. B
IFSS 540131	CONTROLLER	1	01/19/22	B		X	X	B	TO REV. B
IFSS 510362	MOUNTING PLATE ASSEMBLY	1	01/19/22	B		X	X	B	TO REV. B
IFSS 261322	FLAT CONTROLLER MOUNTING PLATE	1	09/01/14	A		X	X	B	TO REV. A
IFSS 110008	CONTROLLER COVER	1	09/01/14	A		X	X	B	TO REV. A
IFSS 300398	PROP ADAPTER	1	09/01/14	A		X	X	B	TO REV. A
IFSS 300396	KEY	1	09/01/14	A		X	X	B	TO REV. A
IFSS 261318	STANDOFF	1	09/01/14	A		X	X	B	TO REV. A
IFSS 120128	FAA/PMA PLACARD	1	09/01/14	A		X	X	B	TO REV. A
IFSS 120123	MANUFACTURERS PLACARD	1	09/01/14	A		X	X	B	TO REV. A
IFSS 120124	MANUFACTURERS PLACARD	1	09/01/14	A		X	X	B	TO REV. A
IFSS 050143-2 DCB	5" DC BRUSHLESS 2 SPEED BLOWER ASSEMBLY	1	08/04/23	C		X	X	B	TO REV. C
IFSS 050143-3 DCB	5" DC BRUSHLESS SINGLE SPEED BLOWER ASSE	1	08/04/23	C		X	X	B	TO REV. C
IFSS 250371	PROPELLER	2	08/04/23	A		X	X	B	TO REV. A
IFSS 580000	5" HUB & PROPELLER ASSY	2	08/04/23	A		X	X	B	TO REV. A
IFSS 540125	CONTROLLER/COVER ASSEMBLY	1	08/04/23	A		X	X	B	TO REV. A
IFSS 261176	HUB, FAN BLADE	2	08/04/23	B		X	X	B	TO REV. B
IFSS 050187	CONTROLLER	1	08/04/23	B		X	X	B	TO REV. B
IFSS 261306	AFT MOTOR COVER	1	08/04/23	A		X	X	B	TO REV. A
IFSS 040016	5" AXIAL HOUSING	1	08/04/23	A		X	X	B	TO REV. A
IFSS 040017	STANDOFF	1	08/04/23	A		X	X	B	TO REV. A
PURCHASE PARTS DRAWINGS									
010001-1	COMPRESSOR SD-505	1	09/01/14	C		X		B	TO REV. C
010001-1-O	COMPRESSOR SD-505	1	09/01/14	C		X		B	TO REV. C
010001-2-O	COMPRESSOR SD-505	1	09/01/14	B		X		B	TO REV. B
010001-3-O	COMPRESSOR SD-505	1	09/01/14	C		X		B	TO REV. C
010004	COMPRESSOR SD-507 (SE-507)	1	09/01/14	B		X	X	B	TO REV. B
010004-1	COMPRESSOR ASSY SD-507	1	09/01/14	B		X	X	B	TO REV. B
010004-3	COMPRESSOR	1	08/04/23	C		X		B	TO REV. C
010011	BEARING	1	09/01/14	B		X	X	B	TO REV. B
010012	CLUTCH PLATE SD-505	1	09/01/14	B		X	X	B	TO REV. B
010013	CLUTCH PLATE, SD-505	1	09/01/14	B		X	X	B	TO REV. B
010014	CLUTCH PLATE, SD-507	1	09/01/14	B		X	X	B	TO REV. B
010015	CLUTCH PLATE, SD-507	1	09/01/14	C		X	X	B	TO REV. C
030010	LOUVER	1	09/01/14	B		X		B	TO REV. B
030010-1	LOUVER	1	09/01/14	B		X		B	TO REV. B
030012-1	WEMAC-BLACK	1	09/01/14	B		X	X	B	TO REV. B
030012-3	WEMAC, BLACK WITH ADAPTER	1	09/01/14	A		X		B	TO REV. A
030021	PLASTIC WEMAC, BLACK	1	09/01/14	B		X	X	B	TO REV. B
040001	BLOWER HOUSING	1	09/01/14	C		X		B	TO REV. C
040002	COVER PLATE	1	09/01/14	C		X		B	TO REV. C



DRAWING NUMBER	DRAWING TITLE	# OF PAGES	DRAWING DATE	REVISION	DESCRIPTION	AS 350	EC130B4	SIZE	NEW/RVSD
040003	VENTURI RING	1	09/01/14	D		X		B	TO REV. D
040004-8	FAN WHEEL CW	1	08/04/23	D		X		B	TO REV. D
040004-9	FAN WHEEL CW	1	09/01/14	B		X		B	TO REV. B
050000	SWITCH W/BUTTON	1	09/01/14	D		X	X	B	TO REV. D
050001	SWITCH W/O BUTTON	1	09/01/14	C		X	X	B	TO REV. C
050002	SWITCH	1	09/01/14	C		X	X	B	TO REV. C
050006	SWITCH W/O BUTTON	1	09/01/14	D		X	X	B	TO REV. D
050006-2	SWITCH W/BUTTON	1	09/01/14	D		X	X	B	TO REV. D
050007	SWITCH BUTTON	1	09/01/14	C		X	X	B	TO REV. C
050008	RELAY 24VDC SPST	1	09/01/14	C		X	X	B	TO REV. C
050019-7	RELAY 24VDC SPST	1	09/01/14	B		X	X	B	TO REV. B
050024-2	RESISTOR 100W 2 OHM	1	09/01/14	F		X	X	B	TO REV. F
050026	TIMER	1	09/01/14	C		X	X	B	TO REV. C
050031	BRUSH	1	09/01/14	B		X	X	B	TO REV. B
050032	BRUSH CAP	1	09/01/14	B		X	X	B	TO REV. B
050033	COIL, 24 VDC	1	01/19/22	C		X	X	B	TO REV. C
050034	COIL, 24 VDC	1	09/01/14	B		X	X	B	TO REV. B
050035	BRUSH	1	09/01/14	B		X	X	B	TO REV. B
050038	BRUSH	1	09/01/14	B		X	X	B	TO REV. B
050043	BRUSH	1	09/01/14	B		X	X	B	TO REV. B
050044	CIRCUIT BOARD FRESH AIR	3	09/01/14	B			X	B	TO REV. B
050052	MOTOR 24VDC DBL. SHAFT	1	01/19/22	E		X		B	TO REV. E
050068	12V REGULATOR	1	09/01/14	C		X	X	B	TO REV. C
050084	FAN, VANE AXIAL, 24 VDC, 7"	3	09/01/14	B		X	X	B	TO REV. B
050107	SWITCH, LOW PRESSURE	1	09/01/14	E		X	X	B	TO REV. E
050108	PLUG, 4 PIN	1	09/01/14	B		X	X	B	TO REV. B
050109	4 PIN RECEPTACLE	1	09/01/14	B		X	X	B	TO REV. B
050110	CABLE CLAMP KIT SHELL SIZE = 11	1	09/01/14	D		X	X	B	TO REV. D
050111	PLUG, 9 PIN	1	09/01/14	C		X		B	TO REV. C
050112	RECEPTACLE, 9 PIN	1	09/01/14	C		X		B	TO REV. C
050113	CABLE CLAMP KIT SHELL SIZE = 13	1	09/01/14	B		X		B	TO REV. B
050114	RECEPTACLE IN LINE	1	09/01/14	C		X		B	TO REV. C
050115	PLUG, CANNON	1	09/01/14	C		X	X	B	TO REV. C
050116	RECEPTACLE SINGLE PIN	1	09/01/14	B		X	X	B	TO REV. B
050117	CABLE CLAMP	1	09/01/14	C		X	X	B	TO REV. C
050118	PLUG	1	09/01/14	C		X	X	B	TO REV. C
050119	RECEPTACLE	1	09/01/14	C		X	X	B	TO REV. C
050131	RESET RELAY	1	09/01/14	C		X	X	B	TO REV. C
050132	SERVO	1	09/01/14	D		X	X	B	TO REV. D
050134	CLEVIS ROD ASSY	1	09/01/14	B		X	X	B	TO REV. B
050137	RESET RELAY	1	09/01/14	B		X	X	B	TO REV. B
050144	BRUSH	1	09/01/14	B		X	X	B	TO REV. B
060004	5" DUCT	1	02/04/08	A		X	X	B	TO REV. A
060005	4 GROOVE BELT	1	08/04/23	D		X	X	B	TO REV. D
060006	5 GROOVE BELT	1	09/01/14	B		X	X	B	TO REV. B
060018	FLAT BELT	1	08/04/23	E		X		B	TO REV. E
060018-1	FLAT BELT	1	08/04/23	C		X		B	TO REV. C
060025	2 1/2" DUCT	1	09/01/14	B		X	X	B	TO REV. B
060036	3" BAND CLAMP	1	01/19/22	C		X	X	B	TO REV. C
060037	1" BAND CLAMP	1	08/04/23	C		X	X	B	TO REV. C
070005	DRAIN TUBING	1	09/01/14	B		X	X	B	TO REV. B
070076	ALUMINUM FOIL TAPE	1	09/01/14	B		X	X	B	TO REV. B
070077	.25 HEATSHRINK	1	09/01/14	B		X	X	B	TO REV. B
070077-1	.125 HEATSHRINK	1	09/01/14	B		X	X	B	TO REV. B

RSG PRODUCTS INC.
 440 West Ln
 Suite 100
 Saginaw TX 76131



Drawing List DL-9 Rev V
 August 04, 2023

DRAWING NUMBER	DRAWING TITLE	# OF PAGES	DRAWING DATE	REVISION	DESCRIPTION	AS 350	EC130B4	SIZE	NEW/RVSD
070077-2	.375 HEATSHRINK	1	09/01/14	B		X	X	B	TO REV. B
070077-3	.50 HEATSHRINK	1	09/01/14	B		X	X	B	TO REV. B
070078	FOAM INSULATION TAPE	1	08/04/23	C		X	X	B	TO REV. C
070078-O	PT-1 CORK INSULATION TAPE	1	09/01/14	A		X	X	B	TO REV. A
070087	LINKAGE	1	09/01/14	B		X	X	B	TO REV. B
080005	SCREEN EM-3	1	08/04/23	D		X	X	B	TO REV. D
080006	1/2 X 1/2 .047 SCREEN	1	09/01/14	B		X	X	B	TO REV. B
080048	SCREEN	1	09/01/14	C		X	X	B	TO REV. C
090002	EXPANSION VALVE	1	09/01/14	B		X		B	TO REV. B
090002-"O"	EXPANSION VALVE	1	09/01/14	C		X	X	B	TO REV. C
090002-2	EXPANSION VALVE	1	09/01/14	B		X		B	TO REV. B
090004	HIGH PRESSURE SWITCH	1	08/04/23	E		X	X	B	TO REV. E
090004-1	HIGH PRESSURE SWITCH	1	09/01/14	B		X	X	B	TO REV. B
090016-2	RECIEVER/DRIER	1	09/01/14	C		X		B	TO REV. C
090016-5	RECIEVER / DRIER	1	08/04/23	E		X	X	B	TO REV. E
090018	DRAIN TUBE 3/8" I.D.	1	09/01/14	C		X	X	B	TO REV. C
090018-1	DRAIN TUBE 1/2" I.D.	1	09/01/14	C		X	X	B	TO REV. C
090089	#6 NYLON BARRIER HOSE	1	08/04/23	C		X	X	B	TO REV. C
090090	#8 NYLON BARRIER HOSE	1	08/04/23	C		X	X	B	TO REV. C
090091	#10 NYLON BARRIER HOSE	1	01/19/22	C		X	X	B	TO REV. C
090092	6# R134A O-RING	1	01/19/22	D		X	X	B	TO REV. D
090093	8# R134A O-RING	1	01/19/22	D		X	X	B	TO REV. D
090094	10# R134A O-RING	1	01/19/22	D		X	X	B	TO REV. D
09-STD-21-101	#10 FITTING STRAIGHT MALE	1	08/04/23	B		X		B	TO REV. B
100100	DRAIN NIPPLE 3/8"	1	09/01/14	B		X	X	B	TO REV. B
100100-1	DRAIN NIPPLE 1/2"	1	09/01/14	C		X	X	B	TO REV. C
100126-"O"	5/8" X #10 X 90 FEMALE O-RING	1	09/01/14	B		X	X	B	TO REV. B
100127-"O"	5/8" X #10 X 45 FEMALE O-RING	1	09/01/14	B		X	X	B	TO REV. B
100128-"O"	5/8" X #10 X STRIGHT FEMALE O-RING	1	08/04/23	C		X	X	B	TO REV. C
100129-"O"	1/2" X #8 X 90 FEMALE O-RING	1	08/04/23	D		X	X	B	TO REV. D
100130-"O"	1/2" X #8 X 45 FEMALE O-RING	1	08/04/23	C		X	X	B	TO REV. C
100131-"O"	1/2" X #8 X STRAIGHT FEMALE O-RING	1	01/19/22	C		X	X	B	TO REV. C
100132-"O"	3/8" X #6 X 90 FEMALE O-RING	1	01/19/22	C		X	X	B	TO REV. C
100133-"O"	3/8" X #6 X 45 FEMALE O-RING	1	09/01/14	B		X	X	B	TO REV. B
100134-"O"	3/8" X #6 STRAIGHT FEMALE O-RING	1	08/04/23	C		X	X	B	TO REV. C
100135	#6 X #6 SPLICE W/R134A SERVICE PORT	1	08/04/23	C		X	X	B	TO REV. C
100136	#10 X #10 X INLINE W/R134A SERVICE PORT	1	09/01/14	B		X	X	B	TO REV. B
100137-"O"	3/8" #6 TEE FITTING	1	09/01/14	D		X	X	B	TO REV. D
100140	5/8" X #10 X 90 FEMALE FLARE	1	09/01/14	B		X		B	TO REV. B
100141	#10 X #10 X #10 TEE SPLICER	1	09/01/14	B		X	X	B	TO REV. B
100143	#6 X #6 X #6 T SPLICER	1	09/01/14	B		X	X	B	TO REV. B
100144	3/8" X #6 SPLICE W.SIGHT GLASS	1	09/01/14	B		X		B	TO REV. B
100147-"O"	1/2 X #6 X STRIAGHT FEMALE O-RING	1	09/01/14	B		X		B	TO REV. B
100148	10 X 10 INLINE W/SCHRADER	1	09/01/14	B		X	X	B	TO REV. B
100149	#6 X #6 SPLICE SCHRADER	1	08/04/23	C		X	X	B	TO REV. C
100162	#10 TEE FITTING	1	01/19/22	D		X		B	TO REV. D
120117	REFRIGERANT LABEL	1	09/01/14	C		X	X	B	TO REV. C
120203	MOTOR AIR FLOW STICKER	1	09/01/14	A		X	X	B	TO REV. A
120204	RSG PRODUCTS INC. ID TAG	1	08/04/23	C		X	X	B	TO REV. C
250371	PROPELLER	1	09/01/14	B		X	X	B	TO REV. B

FLIGHT MANUAL

SUPPLEMENT

FOR

EC130 B4

INTEGRATED FLIGHT SYSTEMS, INC.
4607 B AIRCENTER CIRCLE
RENO, NV 89502

FAA APPROVED

ROTORCRAFT FLIGHT MANUAL SUPPLEMENT

FOR

EUROCOPTER FRANCE

MODEL: EC 130 B4

REGISTRATION NO.: _____

SERIAL NO.: _____

This supplement must be attached to the DGAC approved Rotorcraft Flight Manual, November 29, 2000 when Integrated Flight Systems, Inc. air conditioning system is installed in accordance with Supplemental Type Certificate number SH3509SW. The information contained herein supplements the basic Rotorcraft Flight Manual only in those areas listed. For limitations, procedures, and performance information not contained in this supplement, consult the basic Rotorcraft Flight Manual.

FAA APPROVED:

acting Manager, Flight Test Branch, ANM-160L
Federal Aviation Administration
Los Angeles Aircraft Certification Office
Transport Airplane Directorate

Date: *February 6, 2004*

Integrated Flight Systems, Inc.
4607 B Aircenter Circle
Reno, NV 89502
RFM Supplement Air Conditioner Kit
RFM-130-00-031HP STC#SH3509SW

Rotorcraft Flight Manual
Supplement for Eurocopter
France EC 130 B4

MODEL EC 130 B4

LOG OF REVISIONS

REVISION:ORIGINAL ISSUE

<u>PAGE</u>	<u>DATE</u>	<u>REVISION NO.</u>
1	February 6, 2004	Original
2	February 6, 2004	Original
3	February 6, 2004	Original
4	February 6, 2004	Original
5	February 6, 2004	Original
6	February 6, 2004	Original
7	February 6, 2004	Original
8	February 6, 2004	Original
9	February 6, 2004	Original

REVISED PAGES WILL BE DENOTED WITH “ * “ FOLLOWING PAGE NUMBER

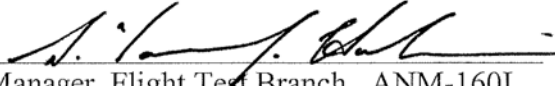
FAA Approved: 
acting Manager, Flight Test Branch , ANM-160L
Federal Aviation Administration
Los Angeles Aircraft Certification Office
Transport Airplane Directorate

Date: Feb. 6, 2004

NOTE: Revised portions of affected pages are identified by vertical black line in the margin adjacent to the change.

INDEX

Log of Revisions.....	2
1.0 General	4
2.0 Operating Limitations	4
3.0 Emergency Procedures	4
4.0 Normal Procedures	4-5
5.0 Performance	5

APPENDIX

A. 0 System & Description	6
A. 1 Electrical Loading	7
A. 2 Weight & Balance	7
A. 3 Configurations/Options	8-9

1.0 GENERAL

The installation consists of a belt drive vapor-cycle air conditioning system driven at the transmission for further description refer to Appendix A.0 System & Description.

2.0 OPERATING LIMITATIONS

The air conditioning system must be “OFF” during engine start.

Operation of the air conditioning system is prohibited if the total electrical load will exceed continuous load rating (green range) or if generator is inoperative.

3.0 EMERGENCY PROCEDURES

3.1 ENGINE or ELECTRICAL FAILURE PROCEDURES

In the event of an engine failure, turn air conditioner “OFF”

In the event of electrical power failure, turn air conditioner “OFF”.

3.2 FIRE or SMOKE in CABIN

In the event of any of the following, turn air conditioner “OFF”.

1. Cabin or other fire
2. Presence of smoke in cockpit

4.0 NORMAL PROCEDURES

4.1 Ground Operation

Air conditioning system operation: The air conditioning control switches are located on or near the instrument console.

To turn air conditioner “OFF” – Move switch to “OFF”.

For air circulation without cooling – Move switch to “FAN”.

For air circulation with cooling – Move switch to “A/C”

Select desired blower speeds.

4.2 Flight Operations

Ventilation Control – as desired (Close for cockpit/cabin cooling)

Air conditioning Control Switch – As desired.

Air conditioning Fan Speed Control Switch – As desired

5.0 PERFORMANCE

5.1 Hover In Ground Effect

If air conditioner is operating reduce gross weight capability determined from Figure 5-5 of the basic RFM by 30 pounds for pressure altitudes above 5,400 feet.

5.2 Hover Out of Effect

If air conditioner is operating reduce gross weight capability determined from Figure 5-6 of the basic RFM by 30 pounds.

APPENDIX

A.O SYSTEM AND DESCRIPTION

The air conditioning installation consists of a belt driven vapor cycle air-conditioning system using R-134A as the refrigerant.

The air conditioning system provides for cabin comfort during all operations both on the ground and in flight. During ground operations when the engine is running, cooling may be provided. Controls for the air conditioning system are located on or near the instrument panel. Three switches are provided. The Master Control Selector consists of a rocker type switch, labeled "A/C", "OFF", and "FAN". Selecting the "A/C" position turns on the system's dual evaporator fans, and condenser blower, and belt driven compressor. The second rocker switch is "HIGH", "LOW" evaporator fan speed selection for the forward cockpit. A third rocker switch provides two (2) speed evaporator blower speed selection for the aft cabin. All three switches are located next to each other.

A 5-amp circuit breaker located with the switches disconnects 28 VDC power for controlling air conditioning system power relays placarded as "Master" if pulled the system will be disable electrically and will be inoperative at this time.

A high-pressure safety switch, located under cabin floor, outboard of the right side keel beam disengages the compressor clutch and stops operation of the system in the event of excessive refrigerant pressures. This can occur due to failure of the condenser blower or restricted air intake. The switch will automatically reset itself.

A low-pressure safety switch is located under the cabin floor, outboard of the right side keel beam. It opens and stops operation of the compressor clutch in the event refrigerant loss occurs. The switch will automatically reset. Although both safety switches will reset, the occurrence of the either fault causes a 1-amp circuit breaker in the "Master A/C Electrical Panel" to trip. The compressor clutch and condenser blower are electrically disengaged when this occurs. Maintenance personnel MUST correct the fault once the aircraft is on the ground. Air circulation is still available, even if a fault occurs. The evaporator fan system may be used anytime air circulation is desired. This is accomplished by placing the selector switch in the "FAN" position Temperature control is not provided.

A.1 Electrical loading

The maximum electrical loads of the air conditioning system components:

Condenser blower	1 each @	19amps =	19 amps
Compressor clutch coil	1 each @	2amps =	2 amps
Evaporator fan (fwd)	1 each @	13amps =	13 amps
Evaporator fan (aft)	1 each @	13amps =	13 amps
Vent servo	1 each @	1 amp =	1 amp
System		Total =	48 amps

Load Shedding

Automatic electrical load shedding will not occur if a DC generator failure occurs.

NOTE **During conditions of high DC current use, such as battery recharging after engine start or use of landing lights, it is possible that the electrical load requirements with the air conditioning operating may exceed the rated output of the DC generator system.

A.2 WEIGHT AND BALANCE

Weight and Balance must update to show air conditioning system installation once installation has been performed. Approximate weight is 89 pounds.

See Instructions supplied with kit for actual weights and moment information.

A.3 CONFIGURATIONS / OPTIONS

This system may be utilized in multiple applications. See the following possible Configurations and application for each specific installation possibility.

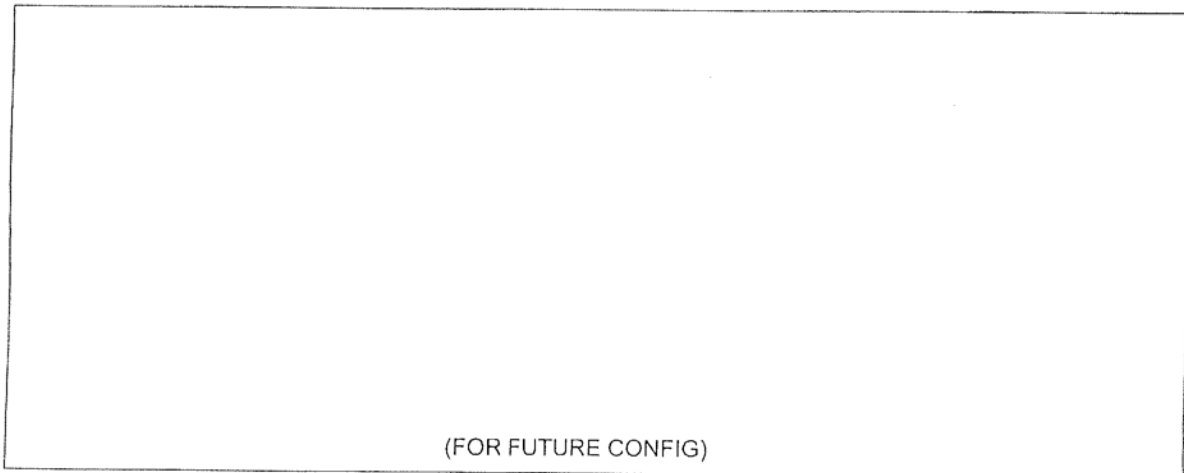
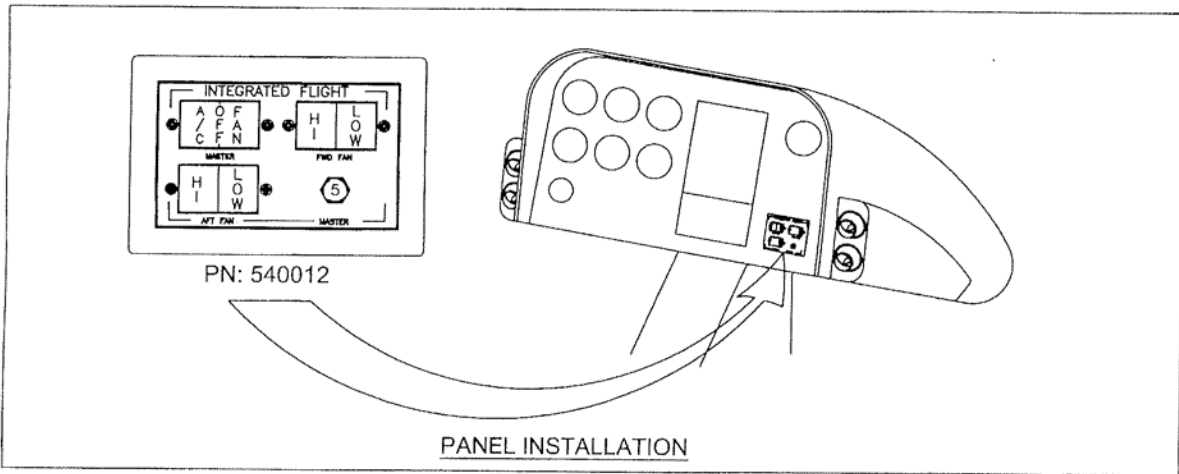
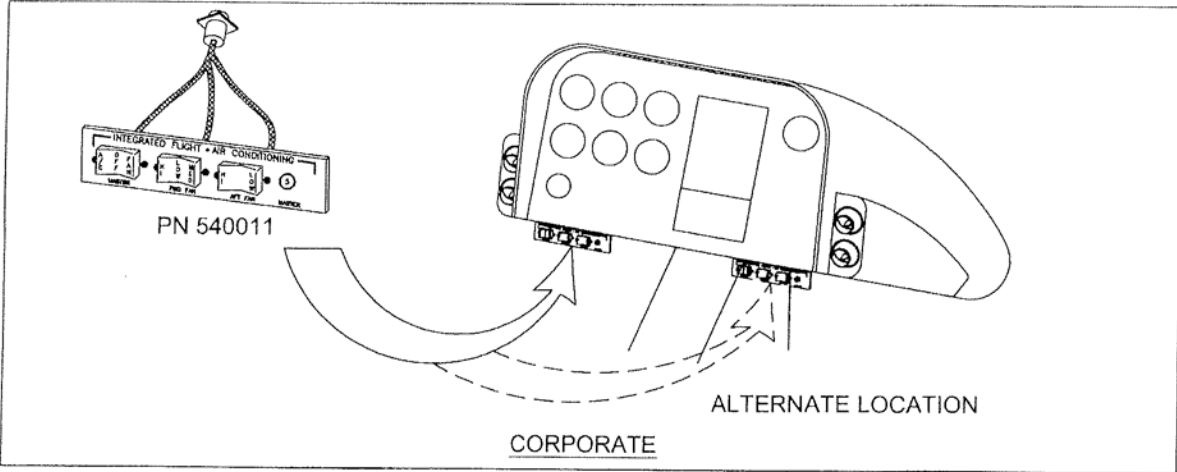

AIR DISTRIBUTION OPTIONS
EC 130



SPECIAL OPTIONS

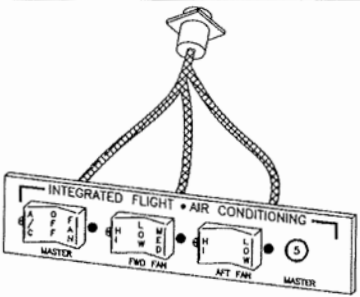

PN 540011: AIR CONDITIONING
CONTROL SWITCHES

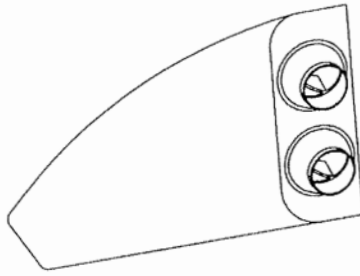

PN 500001: LEFT SIDE
AIR OUTLET

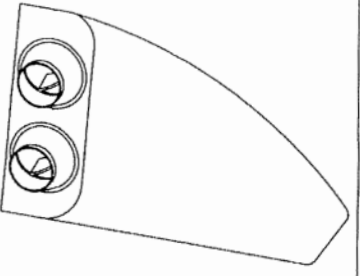

PN 500002: RIGHT SIDE
AIR OUTLET

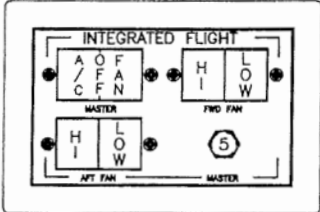

PN: 540012 PANEL MOUNT
SWITCH ASSEMBLY

(THESE ARE STANDARD ITEMS AT THE TIME OF THIS RELEASE,
FUTURE CONFIGURATIONS AND OPTIONS WILL DEPEND ON CUSTOMER
REQUEST AND EXISTING MODIFICATIONS TO AIRCRAFT.)

Step 12

Continued Airworthiness

ASG

PRODUCTS INC.

Air Conditioning System Installation

Instructions for Continued Airworthiness
for
Airbus Helicopters AS-350 B, C, D, D1, B1, B2, B3, BA &
EC-130 B4

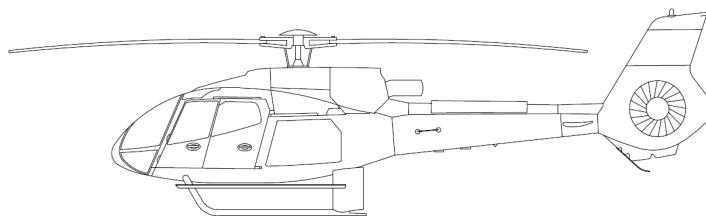
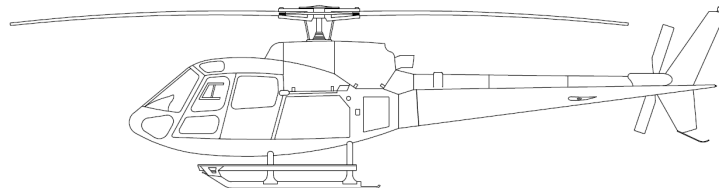

FAA Project Number: SA3109RC-R
STC Number: SH3509SW



DATE:
08/04/2023

DOC No.:
IFSE-0007

REV:
F-1

PAGE:
ii of vii

TITLE:
Air Conditioning System Installation Instructions For Continued Airworthiness for Airbus Helicopters AS-350 B, C, D, D1, B1, B2, B3, BA & EC-130 B4

LOG OF REVISIONS

Instructions for Continued Airworthiness for the Airbus Helicopters AS-350 B, C, D, D1, B, B1, B2, B3, BA and EC-130 B4 Air Conditioning System Installation have been reviewed and found to be acceptable to the Administrator. For the purpose of these Instructions for Continued Airworthiness (ICA), acceptable to the Administrator means the ICA contains the applicable requirements specified in Appendix A to Federal Aviation Regulations Part 27, as appropriate, do not contain any incorrect terminology or incorrect references, and contain a Cover Page, Log of Accepted Revisions, Revision Control Procedure and Record of Temporary Revisions, a list of Effective Pages, and a Table of Contents. Changes to this document will be distributed to owners of the kits within 10 days after the revision is approved. Changes to this document will be indicated by a revision letter in the header, in the Record of Revisions, and on the List of Effective Pages. Contact RSG Products by mail at 440 West Lane Suite 100, Saginaw, TX, 76131. Or by phone at 817-624-6600.

REV	Date	Description	Written By	Checked By	FAA Approval	Approval Date
-	05/03/10	Original Issue	E. Sherrill	P. Ban		
A	06/11/10	Incorporated FAA redlines	E. Sherrill	K. Sheridan		
B	08/08/10	Revised to add Brushless Motor part information, page 87	E. Sherrill	P. Ban		
C	08/12/10	Incorporated FAA redlines	E. Sherrill	P. Ban		
C-1	12/11/13	Revised Chapter 5, 100 hour inspection to change belt on condition. Changed Name.	A. Weidler	S. Weidler		
C-2	09/17/14	Revised Chapter 12 and 21. Removed paragraphs 7 - 9 of Section 12-10-02.d. Removed sight glass troubleshooting information Section 21-00-06 under symptoms.	A. Cuellar	S. Weidler		
C-3	09/30/14	Revised chapter 5 to increase inspection interval to 150 Hours +/- 15	S. Weidler	S. Weidler		
D	11/19/14	Changed Template. Changed Mfr. Name. Was: Eurocopter, Is: Airbus Helicopters. Updated parts list with newer configurations. Parts list is now	S. Johnson	S. Thornton		



DATE:
08/04/2023

DOC No.:
IFSE-0007

REV:
F-1

PAGE:
iii of vii

TITLE:
Air Conditioning System Installation Instructions For Continued
Airworthiness for Airbus Helicopters AS-350 B, C, D, D1, B1, B2, B3, BA &
EC-130 B4

		under Chapter 31. Updated electrical and plumbing diagrams and install drawings. Updated annual/150-hour inspection program in sections 05-00-00 and 05-10-00.				
E	01/12/17	Remove 50 hour inspection table and added Component Overhaul/Replacement schedule for blower motors. Remove, add and update images for Sections 11-00-00, 21-00-00, & 21-10-00	A. Cuellar	S. Weidler		
F	01/19/22	Update to include changes made for MDL Rev U. Change amount of refrigerant to paragraph 1 and 5 on page 18 of 99. Added acceptance criteria to table 5-01 item 8	S. Brewer	K. Musgraves		
F-1	08/04/23	Change time delay of "4 to 8 seconds" to "15 seconds" on page 28 of 99. Updated Weight and Balance information on pages 97, 98 and 99 of 99. Update also includes changes made for MDL Rev V.	S. Brewer	K. Musgraves		

Typed signatures indicate approval. Handwritten signature approvals of this document are on file at RSG Products Inc.



DATE:
08/04/2023

DOC No.:
IFSE-0007

REV:
F-1

PAGE:
v of vii

TITLE:
Air Conditioning System Installation Instructions For Continued
Airworthiness for Airbus Helicopters AS-350 B, C, D, D1, B1, B2, B3, BA &
EC-130 B4

LIST OF EFFECTIVE PAGES

LIST OF REVISIONS	Revision A	December 06, 2012
	Revision B	February 27, 2013
	Revision C	May 14, 2013
	Revision D	November 19, 2014
	Revision E	January 12, 2017
	Revision F	January 19, 2022

LIST OF EFFECTIVE PAGES

<u>TITLE</u>	<u>PAGES</u>	<u>REV.No</u>
Cover	i	D
Log of Revisions	ii	D
Record of Temporary Revisions	iv	D
List of Effective Pages	v	D
Table of Contents	vi - vii	D
Chapter 1 Introduction	1	D
Chapter 4 Airworthiness Limitation	2	D
Chapter 5 Continued Airworthiness Inspections and Overhaul	3 - 9	E1
Chapter 6 Dimensions and Access	10 - 12	D
Chapter 11 Markings and Placards	13	E
Chapter 12 Servicing Maintenance Practices	14 - 30	D
Chapter 20 Standard Practices	31 - 43	E1
Chapter 21 Air Conditioning	44 - 59	E
Chapter 31 Illustrated Parts List	60 - 83	D
Chapter 98 Wiring Diagrams and Plumbing Schematics	84 - 96	D
Appendix A Weight and Balance	97 - 99	D



DATE:
08/04/2023

DOC No.:
IFSE-0007

REV:
F-1

PAGE:
vi of vii

TITLE:
Air Conditioning System Installation Instructions For Continued
Airworthiness for Airbus Helicopters AS-350 B, C, D, D1, B1, B2, B3, BA &
EC-130 B4

Table of Contents

LOG OF REVISIONS.....	ii
RECORD OF TEMPORARY REVISIONS.....	iv
LIST OF EFFECTIVE PAGES.....	v
Chapter 1	1
Section 01-00-00 Introduction	1
Chapter 4	2
Section 04-00-00 Airworthiness Limitations	2
Chapter 5	3
Section 05-00-00 Continued Airworthiness Inspection	3
Section 05-10-00 Continued Airworthiness Scheduled Inspection	6
Chapter 6	10
Section 06-00-00 Dimensions and Access.....	10
Chapter 11	13
Section 11-00-00 Placards and Markings.....	13
Chapter 12	14
Section 12-00-00 Servicing Maintenance Practices.....	14
Section 12-10-00 Charging Practices.....	15
Section 12-20-00 Clutch Servicing Practices	20
Section 12-30-00 System Leak Check.....	26
Section 12-40-00 Fitting Torque Procedures	27
Section 12-50-00 Normal Operation Functional Test.....	28
Section 12-60-00 Belt Tension Procedure.....	29
Section 12-70-00 Drive Belt Change Procedure	30
Chapter 20	31
Section 20-00-00 Standard Practices.....	31
Section 20-10-00 Torques Maintenance Practices	32
Section 20-30-00 Painting Maintenance Practices.....	37



DATE:
08/04/2023

DOC No.:
IFSE-0007

REV:
F-1

PAGE:
vii of vii

TITLE:
Air Conditioning System Installation Instructions For Continued
Airworthiness for Airbus Helicopters AS-350 B, C, D, D1, B1, B2, B3, BA &
EC-130 B4

Section 20-40-00 Corrosion Control Maintenance Practices.....	38
Section 20-50-00 Mechanical Fastener Sealing Methods.....	42
Section 20-90-00 Dye-Penetrant Inspection Methods	43
Chapter 21	44
Section 21-00-00 Air Conditioning.....	44
Section 21-10-00 Illustrated Parts List	60
Chapter 98	84
Section 98-00-00 Wiring Diagrams and Plumbing Schematics	84
APPENDIX A Weight and Balance.....	96



DATE:
08/04/2023

DOC No.:
IFSE-0007

REV:
F-1

PAGE:
1 of 99

TITLE:
Air Conditioning System Installation Instructions For Continued
Airworthiness for Airbus Helicopters AS-350 B, C, D, D1, B1, B2, B3, BA &
EC-130 B4

Chapter 1

Section 01-00-00 Introduction

These are accepted Instructions for Continued Airworthiness for modifications performed in accordance with the Airbus Helicopters AS-350 B, C, D, D1, B, B1, B3, BA and EC-130 B4 Belt-Driven Vapor Cycle Air Conditioning System Installation. All references to the Air Conditioning System in this document will refer to the Belt-Driven Air Conditioning System Installation and other related components specified in STC – SH3509SW. Whether modified by Rotorcraft Services Group or by another Agency with expressed permission from RSG these Instructions for Continued Airworthiness (ICA) should be supplied to the owner/operator of the STC at the time of completion. Subsequent accepted changes to the ICA will be submitted by Rotorcraft Services Group for distribution to owners and operators of the STC.

This, Instructions for Continued Airworthiness, is intended to supplement the AS-350 B, C, D, D1, B, B1, B2, B3, BA, and EC-130 B4 rotorcraft maintenance manuals provided by Airbus Helicopters. The information, procedures, requirements, and limitations contained in this, Instructions for Continued Airworthiness, for this type design change supersede the information, procedures, requirements, and limitations contained in the rotorcraft's maintenance manual when the type design change is installed on the Type Certificate Holder's rotorcraft.



DATE:
08/04/2023

DOC No.:
IFSE-0007

REV:
F-1

PAGE:
2 of 99

TITLE:
Air Conditioning System Installation Instructions For Continued
Airworthiness for Airbus Helicopters AS-350 B, C, D, D1, B1, B2, B3, BA &
EC-130 B4

Chapter 4

Section 04-00-00 Airworthiness Limitations

“The Airworthiness Limitations section is FAA approved and specifies inspections and other maintenance required under §§43.16 and 91.403 of the Federal Aviation Regulation unless an alternative program has been FAA approved.”

There are no additional airworthiness limitations associated with the Air Conditioning System Installation.

There are no life limited components associated with the Air Conditioning System Installation.

Chapter 5

Section 05-00-00 Continued Airworthiness Inspection and Overhaul

1. General

This chapter contains time limit intervals for the Component Overhaul Schedule and Scheduled Inspection for the Air Conditioning System. This chapter is to be added to the approved scheduled inspection for the rotorcraft.

2. Component Overhaul Schedule & Scheduled Maintenance Practices

This chapter describes the inspection that must be accomplished on the Air Conditioning System Installation at Scheduled Inspection intervals. Scheduled Inspection requirements must be complied with at the hourly and/or calendar time intervals specified. Refer to Tables 5-01 and 5-02, in Section 05-10-00 for hourly and/or calendar inspection schedules.

3. Conditional Inspection

After any operational incident involving hard landings, sudden stoppage of the drive train or water immersions the system must not be operated and an Annual or 150 flight hour inspection is required.

4. Documentation

Aircraft mechanics, owners, or operators are required to keep records of the aircraft systems inspections and repairs. This includes, but is not limited to, airworthiness directives, service notices, scheduled inspections, records and life limited components.

5. Definitions

The following is short descriptions of words and terms used in the procedures for the required scheduled inspections.

- **Ambient air temperature:** The temperature of the air surrounding a person.
- **Charging station:** An air conditioning system service.
- **Cold:** The absence of heat.
- **Condensation:** The process of changing a vapor into a liquid.
- **Condition:** The state of an item or component compared to a known standard.



DATE:
08/04/2023

DOC No.:
IFSE-0007

REV:
F-1

PAGE:
4 of 99

TITLE:
Air Conditioning System Installation Instructions For Continued
Airworthiness for Airbus Helicopters AS-350 B, C, D, D1, B1, B2, B3, BA &
EC-130 B4

- **Damage:** Physical deterioration of a component.
- **Desiccant:** A material used in the receiver/dryer bottle, to absorb moisture from the refrigerant.
- **Evaporate:** To change from a liquid into a vapor.
- **Examine:** Look carefully to find the condition of the component. Find how that condition is related to a specific standard.
- **Heat load:** The amount of heat which the air conditioner is required to remove from the aircraft cabin.
- **Inches of Mercury:** A measurement of pressure normally used for pressures below atmospheric, one i-h of mercury is equal to approximately one-half pound per square i-h.
- **Inspection:** A procedure that includes checking, inspecting and examining a system or component.
- **Maintenance:** The servicing and/or repair of a rotorcraft, a system or a component that keeps it serviceable.
- **Pressure, ambient:** The pressure of the air surrounding a body, normally measured in Pounds per Square i-h, or PSIG.
- **Refrigerant:** A fluid which is used in an air conditioning system to absorb heat from the cabin and carry it outside the helicopter where it can be transferred to the outside air.
- **Relative Humidity:** The ratio of the amount of water vapor in the air to the amount of water vapor required to saturate the air at the existing temperature.
- **Scheduled Inspection:** An inspection procedure that must occur at a specified calendar interval or at specific operational time intervals. Scheduled Inspections are required to help ensure the rotorcraft stays airworthy.
- **Security:** Term used for inspection of hardware and components to make sure they are properly attached and tightened.
- **Temperature Differential:** Difference in temperature.
- **Thermostat:** An air condition control which senses the temperature of the evaporator coil and causes the system to cycle or by-pass to maintain the proper temperature of cooling air.
- **Vacuum:** A negative pressure, or pressure below atmospheric; it is usually expressed in inches of mercury.
- **Vapor:** The gaseous state of a material.



DATE:
08/04/2023

DOC No.:
IFSE-0007

REV:
F-1

PAGE:
5 of 99

TITLE:
Air Conditioning System Installation Instructions For Continued
Airworthiness for Airbus Helicopters AS-350 B, C, D, D1, B1, B2, B3, BA &
EC-130 B4

6. Abbreviations:

- **ICA:** Instructions for Continued Airworthiness
- **TD:** Temperature differential
- **In:** Inches
- **InHg:** Inches of Mercury
- **lbs:** Pounds
- **oz:** Ounces
- **Psig:** Pounds per Square I-h (gauge)
- **gr:** Grams
- **kg:** Kilograms
- **kgcm:** Kilograms Per Centimeter
- **ml:** Milliliters
- **mm:** Millimeters
- **N-m:** Newton-meters

Section 05-10-00 Continued Airworthiness Scheduled Inspection

1. General

This section contains requirements for scheduled inspection.

2. Scheduled Inspection Program

The Air Conditioning System Installation requires one scheduled inspection in order to maintain continued airworthiness. Every effort should be made to perform the inspection with the aircraft placed in a clean well-lit environment.

a) Annual or 150-Hour Inspection

The inspection is required to be performed annually or every 150 hours of rotorcraft time-in-service, whichever comes first, + 15 hours not to exceed 165 hours. If inspection is overflowed beyond 165 hours then overflowed time must be deducted from the next inspection due. Inspection Table 5-01 specifies the requirements of the annual inspection.

b) Component Overhaul/Replacement Schedule

The blower manufacturer recommends TBO at 1000 hours.

A blower failure will result in a reduction in cooling, but no safety-of-flight issues are involved. Component Overhaul/Replacement Schedule Table 5-02 specifies the requirements of overhaul/replacement hours.

3. Tools and Special Tools for Scheduled Inspection

Although not necessarily considered special tools, the adjustable ball swivel mirror and bright flashlight and / or drop light are standard requirements for doing inspections. These items should be used freely and frequently to enhance inspection quality and help ensure discrepancies are not missed. It is important to have adequate lighting for all phases of the inspection.

The special tools necessary for the Air Conditioning System Installation inspection are listed as follows:

- a) Vacuum Pump
- b) Gauge Manifold
- c) Vacuum Cleaner
- d) Pull Scale



DATE:
08/04/2023

DOC No.:
IFSE-0007

REV:
F-1

PAGE:
7 of 99

TITLE:
Air Conditioning System Installation Instructions For Continued
Airworthiness for Airbus Helicopters AS-350 B, C, D, D1, B1, B2, B3, BA &
EC-130 B4

Table 5-01 Annual or 150 – Hour Inspection

Registration No.	Serial No.	Helicopter Total Hours
<ul style="list-style-type: none"> The inspection shall be accomplished annually or every 150 hours of rotorcraft time-in-service, whichever comes first, + 15 hours not to exceed 165 hours. If inspection is overflowed beyond 165 hours then overflowed time must be deducted from the next inspection due. Initial each item after accomplishing the inspection. Record all findings and attach a copy of findings to this inspection form. After correction of all findings, make maintenance record entry. 		
PRE-INSPECTION		Initial
1. Review Airworthiness Directives.		
2. Review records for the Air Conditioning System.		
3. Review log books for discrepancies.		
INSPECTION		Initial
1. Perform an operational test of the system in accordance with Section 12-50-00		
2. Inspect the condition of the belt for cracks, deterioration, separation and worn or flat spots. Change belt if necessary. Check belt for proper tension (Ref. 12-60-00 Belt Tension).		
3. Inspect the compressor for a true turning and free clutch. One mechanic should turn the main rotor blade while another observes the belt and clutch faceplate. Turn system to "A/C" and check magnetic operation of clutch faceplate. Inspect compressor ground wire for condition and conductivity. If clutch plate and pulley show signs of excessive heat, replace clutch pulley assembly, bearing and coil (Ref. Section 12-20-00 Clutch Servicing Procedures)		
4. Inspect the compressor clutch bearing. It is not mandatory to grease the bearing. If the bearing is greased use a hypodermic needle, without removing the bearing using 3 to 5cc of Mobil 28 grease. This has proven to be satisfactory when performed at regularly scheduled inspections of 500 hours. Some operators flying as much as 200 hours per month have found that re-greasing can occur at more than 500-hour intervals, provided they DO NOT OVER PACK THE BEARING. 100% capacity packing of the bearing can cause a failure to occur in 1 to 1 ½ hours.		
5. Inspect hoses for general condition, cuts or swelling. Replace as required.		
6. Check for security of all plumbing fittings (Ref. Section 12-40-00 Fitting Torque Procedures). Replace fittings as needed. Check security of clamps and anti-chaff material. Perform system leak check (Ref. 12-30-00 System leak check).		



DATE:
08/04/2023

DOC No.:
IFSE-0007

REV:
F-1

PAGE:
8 of 99

TITLE:
Air Conditioning System Installation Instructions For Continued
Airworthiness for Airbus Helicopters AS-350 B, C, D, D1, B1, B2, B3, BA &
EC-130 B4

7. For brushed motors only, access the Aft Evaporator (Ref. Section 6-00-00 Dimensions and Access). Aft evaporator motor has two (2) removable brushes. Detach elbow from top of blower assembly. Remove brushes one (1) at a time. Note position relative to curvature of armature. Inspect brush for wear. Replace if brush is 5/16" or less. Install new brushes and run at 12 VDC (utilizing an independent power source).

Until seating occurs on 70% of the surface (this should be accomplished with motor assembly removed from aircraft). This action will greatly enhance brush life. Reconnect wires to aircraft system and reinstall insulated duct. Run both of the blower/fans in the "FAN" position and perform visual inspection of the assemblies to see that foreign materials have not been ingested into the blower/fan, which might cause blade damage. The blower/fan should also be run at the various speeds available to check the motor operation.

8. Access the condenser (Ref. Section 6-00-00 Dimensions and Access). Check the fins of the condenser coil for cleanliness and ensure that they are straight. If damage has occurred to the fins, a fin comb should be utilized to put them in like new condition. If damaged fins that cannot be straighten account for $\leq 3\%$ of the overall fin-covered surface area of the condenser, the operation of the condenser will remain unaffected.



DATE:
08/04/2023

DOC No.:
IFSE-0007

REV:
F-1

PAGE:
9 of 99

TITLE:
Air Conditioning System Installation Instructions For Continued
Airworthiness for Airbus Helicopters AS-350 B, C, D, D1, B1, B2, B3, BA &
EC-130 B4

Table 5-02 Component Overhaul/ Replacement Schedule

Description	Part Number	Overhaul/Replacement Hours
Aft Evaporator Blower Motor	490017-1-01 (IFSS 050143-3 DCB) 490017-1-02 (IFSS 050143-2 DCB)	The blower manufacturer recommends TBO at 1000 hrs. At the discretion of the operator, it is acceptable to operate the blower until failure. A blower failure will result in a reduction in cooling, but no safety-of-flight issues are involved.
Condenser Blower Motors	IFSS 050143-3 DCB or IFSS 050084-7-2 & IFSS 050084-7-3	Same as above

Chapter 6

Section 06-00-00 Dimensions and Access

1. Access Methods

a) Access Item Identification (Ref. figures 6-01 & 6-02)

- **Condenser-** The condenser is located in one of two positions depending on kit part number (Ref. Section 21.00.00 System Description). The aft mounted condenser (Kit numbers 350-00-031HP and 130-00-031HP) (Ref. figure 6-02) is mounted in the tail boom mounted 5 in. above the baggage floor and is accessed by removing the tail boom closeout panel. The side mounted condenser (Kit Number 350-00-011HP) is located in the right baggage compartment (Ref. figure 6-01) and is accessed by removing to baggage compartment close out panel.
- **Compressor-** The compressor is located aft and to the left side on main transmission deck. It is accessed by opening the upper transmission cowling.
- **Aft Evaporator-** The aft evaporator is located on the right-hand upper transmission deck in all configurations. It is accessed by opening the right-hand transmission cowling forward latch.
- **Forward Evaporator-** In the AS-350 series, the forward evaporator is located on the cockpit floor forward of the pilots' controls. In the EC-130, it is located on the cockpit floor forward of the pedestal and mounted to the pedestal. No additional access method is required.

b) Removal and Installation Methods

Caution: Use of power tools during removal or installation of panels and attaching hardware may damage nut plates or deform holes in composite doors, covers, panels, and fairings.

TITLE:
Air Conditioning System Installation Instructions For Continued
Airworthiness for Airbus Helicopters AS-350 B, C, D, D1, B1, B2, B3, BA &
EC-130 B4

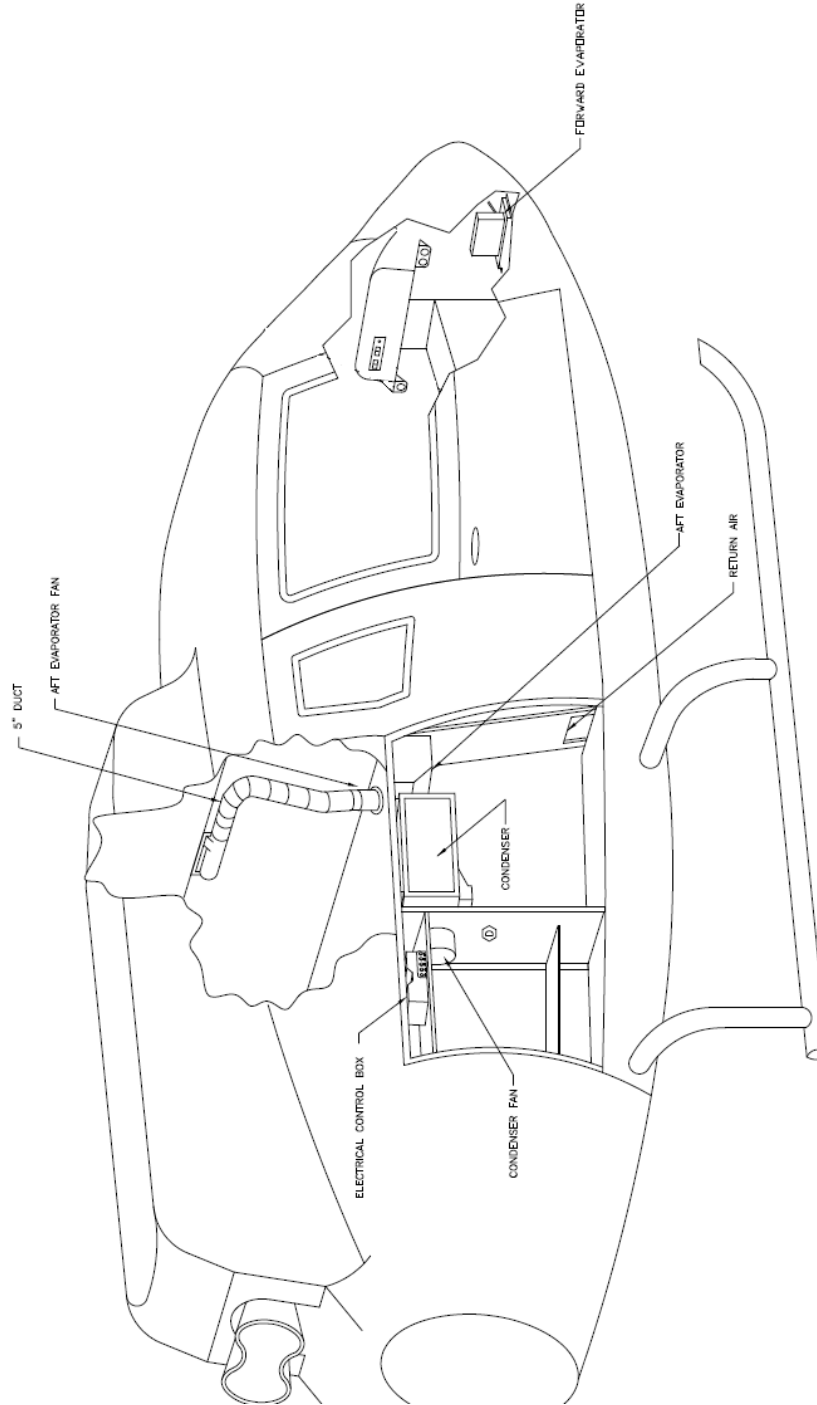

Figure 6-01: Side Mounted Condenser Configuration

TITLE:
Air Conditioning System Installation Instructions For Continued
Airworthiness for Airbus Helicopters AS-350 B, C, D, D1, B1, B2, B3, BA &
EC-130 B4

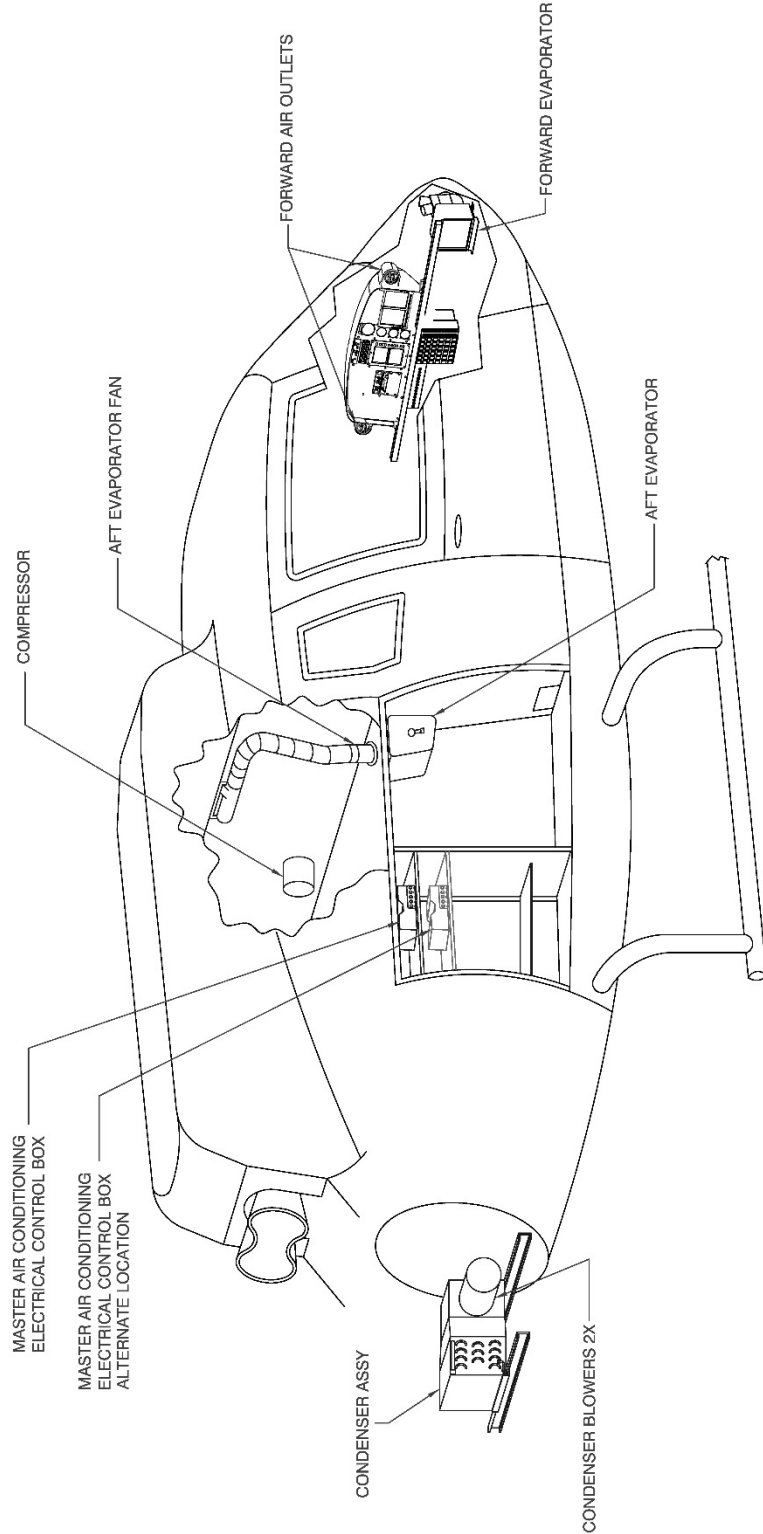
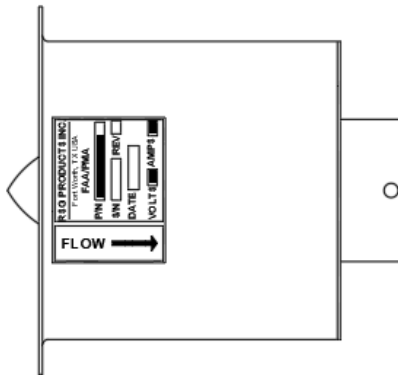

Figure 6-02: Aft Mounted Condenser Configuration

Chapter 11

Section 11-00-00 Placards and Markings

1. Placards and Decals



For PN: IFSS 050143



For PN: 550007-1

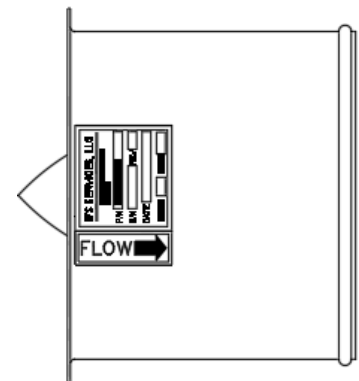

For PN: IFSS 050084

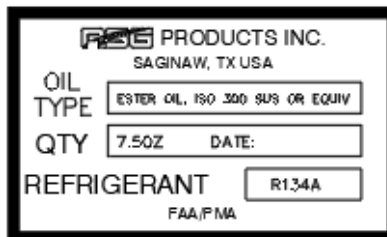

For PN: 590008 & 590008-1

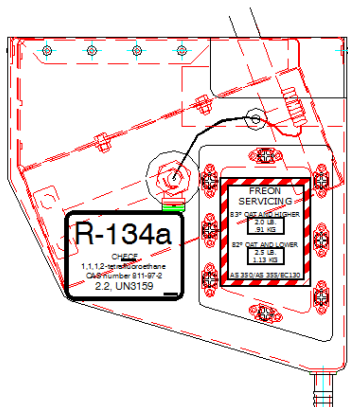

For PN: 560010-O-5 & 560016-O-1



For PN: 050145



DATE:
08/04/2023

DOC No.:
IFSE-0007

REV:
F-1

PAGE:
14 of 99

TITLE:
Air Conditioning System Installation Instructions For Continued
Airworthiness for Airbus Helicopters AS-350 B, C, D, D1, B1, B2, B3, BA &
EC-130 B4

Chapter 12

Section 12-00-00 Servicing Maintenance Practices

1. General

It is assumed in the following practices that the personnel engaged in Charging, Servicing, or Maintenance of the system will be either an experienced air conditioning mechanic under the supervision of a qualified A & P mechanic or an A & P mechanic possessing good air conditioning skills.

Section 12-10-00 Charging Practices

1. Reclaiming

- a) Connect the EPA approved recovery unit services hoses, which shall have shut-off valves to the aircraft air conditioning system service ports.
- b) Operate the recovery equipment as covered by the equipment manufacturers recommended procedure.
- c) Start the recovery process and remove the refrigerant from the aircraft air conditioning system. Operate the recovery unit until the aircraft system has been reduced from a pressure to a vacuum. With the recovery unit shut off for at least 5 minutes, determine that there is not refrigerant remaining in the aircraft air conditioning system. If the aircraft system has pressure, additional recover operation is required to remove the remaining refrigerant. Repeat the operation until the aircraft air conditioning system vacuum level remains stable for two minutes.
- d) Close the valves in the service lines and then remove the service lines from the aircraft system. Proceed with the repair/service. If the recovery equipment has automatic closing valves, be sure they are properly operating.

2. Charging

a) **Prior to Charging the System**

Prior to charging the system with R-134a, the evaporator fan/blower and condenser blower should be checked for operation and direction of airflow. This is most easily done by utilizing a GPU unit for electrical power. Since the compressor is belt driven only those maintenance and operational functions that are electrically powered may be checked either in the hanger or on the ramp without running the engine.

After the GPU is connected to the aircraft and the Aircraft Master Switch is "On", the air conditioning system may be turned "On". Place the rocker switch on the Master Air Conditioning Control Panel to "A/C". It does not cause the compressor to run or refrigerant to be pumped. All evaporator blowers and the forward evaporator fan should start immediately. The 7" condenser blower and clutch will not engage until after approximately 4 seconds after evaporator fan start.

NOTE: SYSTEM MUST HAVE MINIMUM 30 PSI CHARGE

Check airflow of each evaporator fan/blower. Determine that air is coming out of the cockpit and the cabin air outlets.



DATE:
08/04/2023

DOC No.:
IFSE-0007

REV:
F-1

PAGE:
16 of 99

TITLE:
Air Conditioning System Installation Instructions For Continued
Airworthiness for Airbus Helicopters AS-350 B, C, D, D1, B1, B2, B3, BA &
EC-130 B4

Check airflow into and out of condenser air openings.

b) **Charging the System**

*NOTE: All evaporators' fan/blower, condenser blowers, and controls are 28-volt DC.

DANGER: R-134a, particularly liquid R-134a, should never be allowed to come in contact with the eyes or skin. Under normal conditions, R-134a as a gas or vapor is an inert substance and non-poisonous. A flame-type leak detector should never be used because of the danger of fire or explosion around an aircraft. Several electronic leak detectors are available on the market.

Never heat a cylinder of R-134a to produce additional pressure or to squeeze that last bit of refrigerant from the cylinder. If the cylinder has become cooled to the point where additional refrigerant cannot be obtained from it, the only approved method is to place the entire cylinder in a container of warm water. **Do Not Exceed 120 Degrees Fahrenheit.**

Never attempt to repair a leak requiring brazing or soldering within the aircraft structure as fire or explosion can result. Remove the entire assembly from the aircraft to a safe location before attempting such a procedure.

CAUTION: Should R-134a come in contact with the eyes or skin, Do Not attempt first aid beyond the immediate washing of the eye or skin with clear water. A doctor should be contacted immediately for diagnosis and treatment even though the injury may be considered slight.

The refrigerant used in this system R-134a, and no other refrigerant is to be considered. Normal safety practices, such as wearing of gloves and the use of goggles, should be utilized as R-134a could freeze the eyeball instantly were it to come in contact with the eye. Also, frostbite could occur to areas of the skin if R-134a were allowed to come in contact.

Charging of the system is a simple procedure whether on initial or recharging after leakage repair. A set of refrigerant gauges with a minimum of three hoses should be connected to the high side and low side service ports provided.

Prior to charging each newly installed system with R-134a, **you will not need to charge compressor with oil since 7.5 ounces of ESTER oil has already been**

added. Do not add additional oil if replacing a compressor in an existing system.

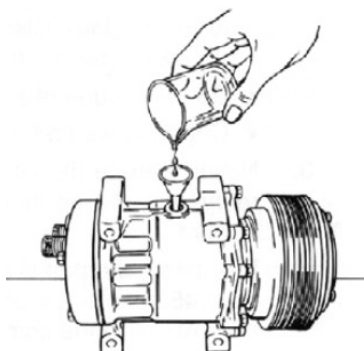

Figure 12 - 01: Adding Oil to the Compressor

c) **Initial Charging**

Tighten any leaking connections or make repairs as necessary to eliminate leaks. Shut off and disconnect hose from the refrigerant cylinder. Connect the hose to a regulator mounted on a cylinder of dry nitrogen. Purge the regulator to center manifold hose. **Close low side valve (left) at manifold. Failure to do so can cause pressure to flow to the low side (left) gauge. Failure of gauge can result.**

Pressurize system to 250-PSI minimum, 300-PSI maximum.

After the system has been rechecked with the leak detector and it is determined that no leaks exist, disconnect the charging hose from the manifold set to the cylinder of nitrogen. Open the valves allowing the R-134a and nitrogen within the system to be collected into an EPA approved recycling until (expelling of refrigerant is not allowed).

Connect a vacuum pump to the center manifold hose. Open both valves and evacuate the system for a minimum of twenty minutes. **(NOTE: For each 1,000 foot rise in altitude above sea level, a decrease below 30" of vacuum of 1" per one thousand feet rise in altitude will occur).**

d) **Adding R134-a Refrigerant**

Close both the manifold valves and connect the center charging hoses to a cylinder of R-134a. Open the valves of the cylinder. Purge the charging hose by loosening it at the charging manifold's center hose. **ONLY THE HIGH SIDE VALVE OF THE CHARGING MANIFOLD MAY NOW BE OPENED**



DATE:
08/04/2023

DOC No.:
IFSE-0007

REV:
F-1

PAGE:
18 of 99

TITLE:
Air Conditioning System Installation Instructions For Continued
Airworthiness for Airbus Helicopters AS-350 B, C, D, D1, B1, B2, B3, BA &
EC-130 B4

The combination of the vacuum still existing and the pressure in the R-134a cylinder transfers the R-134a from the cylinder into the system, **on the high side only**, without the compressor running. If a scale is available, the cylinder may be pre-weighted and **2.5 pounds of refrigerant R-134a added to the system**. No additional refrigerant should be added after the system is in operation. Close manifold.

The system is now ready for operation. **This must be performed on the flight line with the engine at 100%**. As soon as the "A/C" Master Control Switch is turned to "A/C" all 28 VDC evaporator fans will immediately begin operations.

If, after the system has been in the "A/C" mode for at least 2 minutes and cooling is not being accomplished, then check all circuit breakers.

Determine that 28 VDC power is available for control circuitry. Check operations of the relays and contacts

After the compressor has come on line, the entire system is operational with the manifold valve closed on the high side. The R-134a cylinder valve should be closed initially in order to get an accurate reading on the low side gauge of the "system pressure". The reading on the gauge should not be allowed to go below 10 PSI, as this will indicate that the low-pressure safety switch is possibly set too low. It will disconnect the electrical power to the compressor clutch if allowed to open. Open or close the cylinder valve as required to monitor the flow of R-134a from the cylinder into the low side of the system, if additional R-134a is needed. **Smoke test is no longer required for R-134a receiver/drier (without sight glass) like it was for R-12 receiver/drier (with sight glass).**

Charge system to 2.5 lbs. The optimum method of determining the correct charge using at least two digital thermometers and place them near the return air and the discharge air of each evaporator. R-134a can then be added or deleted, as required, until the highest T.D. is noted, per the paragraph below. At that time, the correct amount of refrigerant is installed.

A test sheet should be completed noting the average cabin temperature, the temperature on the return or entering air to all evaporators and the discharge air from the evaporators, at the nearest point. If a Temperature Differential (T.D.) of less than 20 degrees Fahrenheit with a humidity of 30% or less is recorded through the evaporators at sea level, the system should be considered as having possible defects, which will need investigation. At altitudes above sea level, less than 20 degrees Fahrenheit temperature difference may be recorded at humidity of 30% or less. This is due to less dense air moving more rapidly through the evaporators.

e) **Effect of Humidity on TD**

It should be noted that in measurements taken and entered on a test sheet that similar measurements made at a later date, when the humidity is considerably higher, would dramatically change the T.D.

The higher the humidity, as compared to a previous T.D. reading taken with a low humidity, will result in a lower T.D. The reason for this lower T.D. measurement is that when a test is performed at lower humidity, only "SENSIBLE HEAT" is being removed. With higher humidity, a different condition exists. It requires that "LATENT HEAT" containing moisture borne heat must first be removed prior to the removal of the sensible heat

If the system is found to be completely empty of R-134a, a set of charging gauges should be connected to both high and low side service ports and to a cylinder of R-134a. Purge the charging hoses from the cylinder to the service ports with R-134a vapor. Open both the low and high side charging valves and allow pressure from the cylinder to equalize through the system until at least 50 PSI is noted. Utilizing an electronic leak detector, check all fittings on the system to determine the point of leakage. Any fitting indicating an oily or dirty condition is a prime suspect.

f) **Recharging the System**

After the leaks have been found and corrected, pressurize the system with dry nitrogen. Re-check for leaks. Connect a vacuum pump to the system and evacuate the system for a minimum of 20 minutes from both the high and low sides. If the system has been allowed to become contaminated, then the receiver/drier is to be replaced.

It is always good air conditioning practice to replace the receiver/drier whenever it is suspected that moisture has contaminated the system.

The balance of the recharging procedure is exactly the same as pointed out previously under the **Charging Operation**. A judgment must be made as to the amount of oil, if any, lost at the point of leakage. Additional oil may be required to be added to the system. If the refrigerant has been expelled rapidly by the rupture of a line or similar situation, then two (2) ounces of refrigerant oil of the type previously specified should be applied to the system at this time and immediately prior to charging of the system with R-134a.

Section 12-20-00 Clutch Servicing Practices

1. General

These clutch servicing practices are applicable to all compressors that can be installed with the Air Conditioning System Installation.

a) Clutch Armature Assembly Removal

- (1) If armature dust cover is present, remove the 3 or 6 bolts holding it in place and remove cover. If auxiliary sheet metal pulley is present, remove the screws holding it in place. Then remove pulley.
- (2) Insert pins of armature plate spanner into threaded holes of armature assembly.
- (3) Hold armature assembly stationary while removing retaining nut with 3/4 in, 19 mm or 14 mm socket wrench as appropriate. (Ref. Figure 12-02)

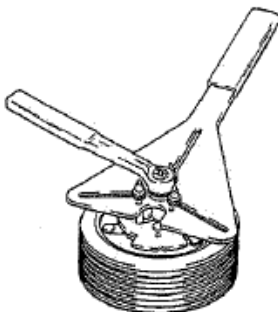

Figure 12 - 02

- (4) Remove armature assembly using puller. Thread 3 puller bolts into the threaded holes in the armature assembly. Turn center screw clockwise until armature assembly comes loose. (Ref. Figure 12-03)

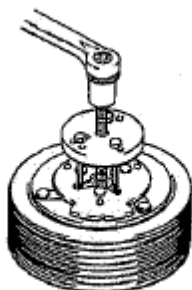

Figure 12 - 03

- (5) If shims are above shaft key, the key and bearing dust cover (if present) must be removed before the shims can be removed.
- (6) Remove bearing dust cover (if present). Use caution to prevent distorting cover when removing it.
- (7) Remove shaft key by tapping loose with a flat blade screwdriver and hammer.
- (8) Remove shims. Use a pointed tool and a small screwdriver to prevent the shims from binding on the shaft.

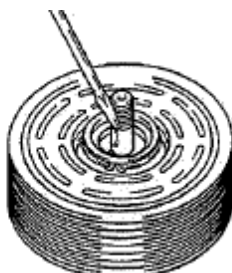

Figure 12 - 04

b) Rotor Assembly Removal

- (1) If bearing dust cover has not been removed, remove it now.
- (2) If internal snap ring for bearing is visible above the bearing, remove it with internal snap ring pliers.
- (3) Remove rotor snap ring.
- (4) Remove shaft key.
- (5) Remove rotor assembly: insert the lip of the jaws into the snap ring groove, place rotor puller shaft protector (puller set) over the exposed shaft, align thumb screws to puller jaws and finger tighten and turn puller center bolt clockwise using a socket wrench until rotor pulley is free. (Ref. Figure 12-05)

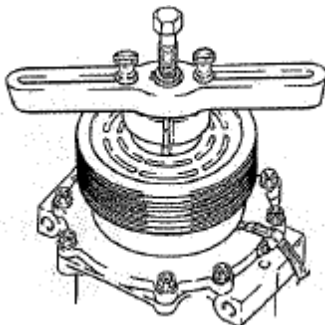

Figure 12 - 05

c) **Field Coil Assembly Removal**

- (1) Loosen lead wire clamp screw with #2 Phillips screwdriver until wire(s) can be slipped out from under clamp.
- (2) Undo any wire connections on the compressor which would prevent removal of the field coil assembly.
- (3) Remove snap ring.
- (4) Remove the field coil assembly. (Ref. Figure 12-06)

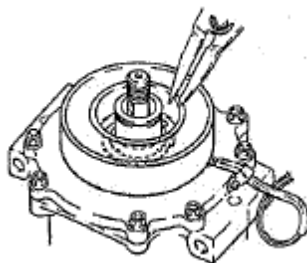

Figure 12 - 06

d) **Field Coil Assembly Installation**

- (1) Reverse the steps of the field coil assembly removal. Protrusion on underside of coil ring must match hole in front housing to prevent movement and correctly locate lead wire(s).

e) **Rotor Assembly Installation**

- (1) Place compressor on support stand, supported at rear end of compressor. If the compressor must be clamped in a vice, clamp only on the mounting ears, never on the body of the compressor.
- (2) Set rotor squarely over the front housing boss.
- (3) Place the rotor installer ring into the bearing bore. Ensure that the edge rests only on the inner race of the bearing, not on the seal, pulley, or outer race of the bearing.
- (4) Place the driver into the ring and drive the rotor down onto the front housing with a hammer or arbor press. Drive the rotor against the front housing step. A distinct change of sound can be heard when using a hammer to install the rotor. (Ref. figure 12-07).

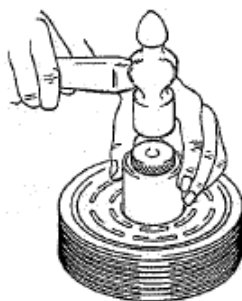

Figure 12 - 07

- (5) Reinstall rotor bearing snap ring, if it has been removed, with internal snap ring pliers. (Ref. figure 12-08)



Figure 12 - 08

- (6) Reinstall rotor retaining snap ring with external snap ring pliers. If a bevel is present in the snap ring, it should be face up (away from the body of the compressor).
- (7) Reinstall rotor bearing dust cover (if present) by gently tapping it into place.

f) **Armature Assembly Installation**

- (1) Install shaft key with pliers. (Ref. figure 12-09)

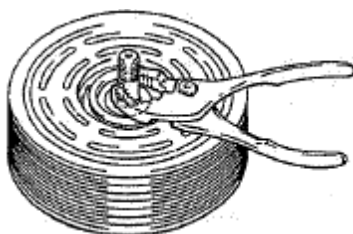

Figure 12 - 09

- (2) Install clutch shims. NOTE: Clutch air gap is determined by shim thickness. When installing a clutch on a used compressor, try the original shims first. When installing a clutch on a compressor that has not had a clutch installed before, first try 0.04 in, 0.02 in and 0.004 in (1.0, 0.5, 0.1 mm) shims.
- (3) Align keyway in armature assembly to shaft key. Using driver and a hammer or arbor press, drive the armature assembly down over the shaft until it bottoms on the shims. A distinct sound change will be noted if driving with a hammer. (Ref. figure 12-10)

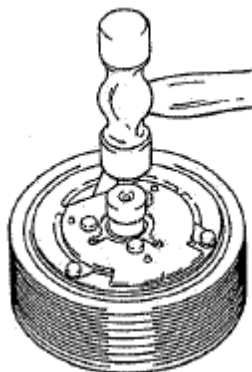

Figure 12 - 10

- (4) Replace retaining nut and torque to specification

1/2-20: 20-25 ft*lb (27-34 N*m)

M8: 11-15 ft*lb (15-21 N*m)

- (5) Check air gap with a feeler gauge. Specification is 0.011-0.019 in (0.3-0.5mm). If gap is not even around the clutch, gently tap down at the high spots. If the overall gap is out of spec, remove the armature assembly and change shims as necessary.

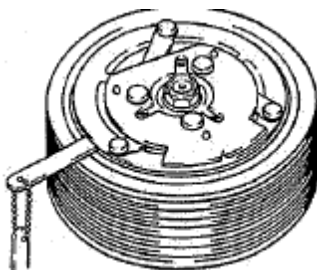

Figure 12 - 11

- (6) Replace armature dust cover (if used) and torque 3 or 6 bolts to specification below.

3-1/4-20 bolts: 2-4 ft*lb (2-5 N*m)

6-M5 bolts: 5-8 ft*lb (7-11 N*m)

NOTE: Over torque of dust cover bolts will cause air gap to become out of spec.



DATE:
08/04/2023

DOC No.:
IFSE-0007

REV:
F-1

PAGE:
26 of 99

TITLE:
Air Conditioning System Installation Instructions For Continued
Airworthiness for Airbus Helicopters AS-350 B, C, D, D1, B1, B2, B3, BA &
EC-130 B4

Section 12-30-00 System Leak Check

1. General

Identification and elimination of system fitting leaks is extremely important to the operation of this air conditioning system installation.

A system which contains a partial charge of refrigerant can be leak tested with the aid of an electronic leak detector and be recharged without evacuating the system.

A new or empty system can be pressurized with nitrogen 70-80 psi (5.1-5.6 kgcm) or R134a 50 psi to conduct a leak survey. Do not use compressed air, for it can introduce moisture into the system causing degradation to the operation of the system.

The preferred method is to use an electronic leak detector in conjunction with a small charge of R134a refrigerant. All checks done in this manner should be conducted with the air conditioner off. Since the refrigerant is heavier than air, leaks are most likely to be detected on the underside of the hoses and fittings. Refrigerants will collect in low areas and provide erroneous leak detection. A stream of compressed air from a nozzle may be useful in clearing the area just prior to conducting a leak test.

If the nitrogen method is used, it will be necessary to mix together a water and mild soap solution. Each fitting or suspected leak area should be brushed with this soap solution and watched for evidence of bubbles formed by the escaping nitrogen.

If a leak is detected at an O-ring fitting, check to ensure proper torque has been applied to the fitting. If the system continues to leak, evacuate the system of refrigerant and install a new O-ring. NOTE: be sure that the O-ring is lubricated with refrigerant oil prior to its installation.

A small amount of leakage (approximately one ounce per year) past the compressor shaft seal is normal. Most leak detectors are sensitive enough to show a leak a magnitude.

Section 12-40-00 Fitting Torque Procedures

1. Fitting Torque Procedures and Torque Values

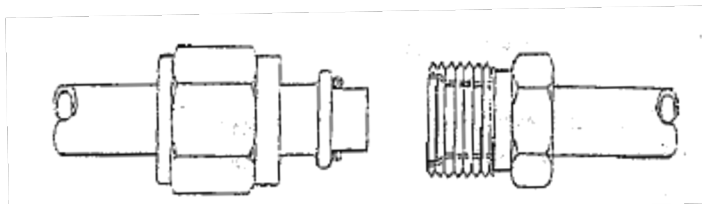

Figure 12 – 12: Insert O-Ring Fittings

- (1) Confirm there is no damage on fittings.
- (2) Apply a thin coating of refrigerant oil to O-ring and female side of fitting.
- (3) Slide B-nut back away from the end of the tube so the O-ring can be seen as the fitting is being slide together. Be careful not to pinch the O-ring during assembly.
- (4) Engage the male end into the female fitting being careful to maintain alignment.
- (5) The male flange should seat fully against the female fitting without the O-ring being pinched.
- (6) It is important to hold the fitting together while sliding the B-nut forward and engaging the threads. Tighten the B-nut by hand and torque per table 12-01. **DO NOT OVER TORQUE.**

Table 12-01 Fitting Torque Values

Fitting #	Torque Value in/lbs (Nm)
#6	30-35 (3.4-4.0)
#8	40-45 (4.6-5.1)
#10	50-55 (5.7-6.3)



DATE:
08/04/2023

DOC No.:
IFSE-0007

REV:
F-1

PAGE:
28 of 99

TITLE:
Air Conditioning System Installation Instructions For Continued
Airworthiness for Airbus Helicopters AS-350 B, C, D, D1, B1, B2, B3, BA &
EC-130 B4

Section 12-50-00 Normal Operation Functional Test

- a. With the aircraft engine operating, electrical system on and functioning normally, move the air conditioner control switch to the "FAN" position.
- b. Move the cockpit fan switch from "LOW" to "HIGH" speed and ensure that air output is present in all the forward air outlets. Repeat the test using the aft cabin fan speed selector switch for the aft cabin air outlets.
- c. Reposition the air conditioner control switch to the "A/C" position and repeat Step 2 above. Cool air should be supplied to the cockpit and cabin vents after a time delay of 15 seconds.
- d. Turn air conditioner switch to "OFF" or the center position. Entire system should shut down.

Section 12-60-00 Belt Tension Procedure

With the compressor drive belt on the drive pulley and the compressor clutch pulley. Tighten bolts at the adjustment arm assuring the belt proper amount of tension. Tighten the lower forward mounting bolt. Use a pull scale to measure the tension. (Ref. figure 12-13). Recommended belt tension values if using a grooved belt is 30 lbs and if using a flat belt is 50 lbs.

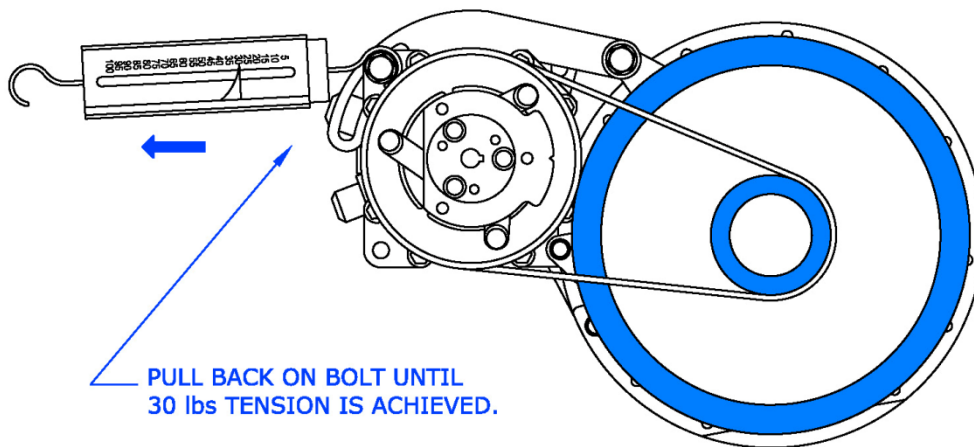

060005 GROOVED BELT

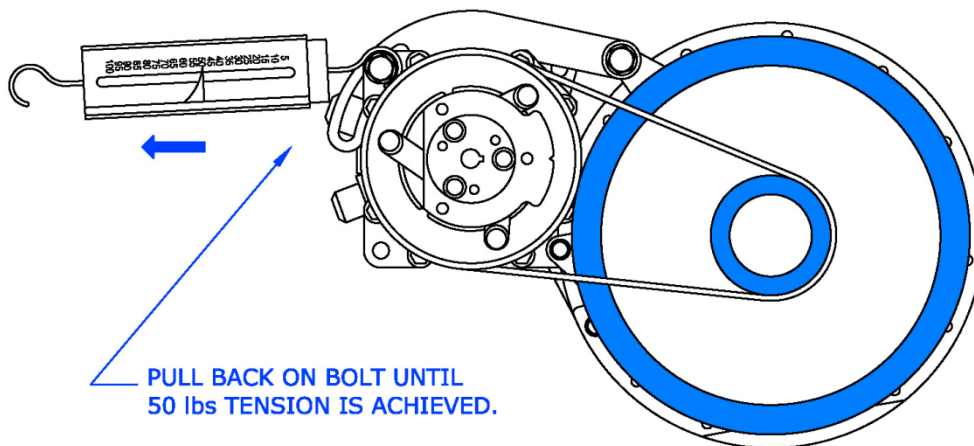

060018-1 FLAT BELT

Figure 12 – 13



DATE:
08/04/2023

DOC No.:
IFSE-0007

REV:
F-1

PAGE:
30 of 99

TITLE:
Air Conditioning System Installation Instructions For Continued
Airworthiness for Airbus Helicopters AS-350 B, C, D, D1, B1, B2, B3, BA &
EC-130 B4

Section 12-70-00 Drive Belt Change Procedure

- a. Access the compressor installation (ref. Section 6-00-00 Dimensions and Access). For compressor information reference Section 21-00-00 Air Conditioning.
- b. Place a support on the transmission deck to support the engine drive while the shaft is disconnected for belt installation.
- c. Remove the cotter pins from the four pins holding the “Gimble Ring” at the Thomas coupling.
- d. Slide the “Gimble Ring” aft to gain access to the Thomas coupling.
- e. Remove the 6 bolts and Thomas coupling connecting the drive shaft and shift slightly aft.
- f. Install two (2) Compressor Drive belts.
- g. Reassemble the Thomas coupling.
- h. Secure 1 belt to the outside of the drive shaft cover for a spare and slip one through the housing and over the drive pulley.
- i. Install the “Gimble Ring” pins and cotter pins. Remove supports.
- j. Install the compressor drive belt on the drive pulley and the compressor clutch pulley. Tighten bolts at the adjustment arm assuring the belt proper amount of tension. (Ref. Section 12-60-00 Belt Tension Procedure). Tighten the lower forward mounting bolt.



DATE:
08/04/2023

DOC No.:
IFSE-0007

REV:
F-1

PAGE:
31 of 99

TITLE:
Air Conditioning System Installation Instructions For Continued
Airworthiness for Airbus Helicopters AS-350 B, C, D, D1, B1, B2, B3, BA &
EC-130 B4

Chapter 20

Section 20-00-00 Standard Practices

This chapter contains maintenance information and procedures that are common standard practices. Information contained in this chapter is standard torque charts and application procedures, corrosion prevention, painting, mechanical fastener sealing, and dye penetrant inspection techniques.

Section 20-10-00 Torques Maintenance Practices

1. Torque Wrenches

a) Torque Wrench Accuracy

Torque wrenches must be of good quality and calibrated at least once a year. Any torque wrench that has been dropped or abused should be calibrated to ensure continued accuracy.

b) Application of Torque Wrench Loads

- (1) Be sure the bolt and nut and the surface they bear on are clean and dry, unless otherwise specified by the manufacturer.
- (2) Run the nut down to near contact with the washer or bearing surface and check the friction drag torque required to turn the nut. Add the friction drag torque to the desired torque to arrive at the "final torque" to be registered on the torque wrench indicator.
- (3) Whenever possible, apply the torque to the nut instead of the bolt. This will reduce rotation of the bolt in the hole and reduce wear.
- (4) Apply a smooth even pull when applying torque pressure.
- (5) If special adapters are used which will change the effective length of the torque wrench, the final torque indication or wrench setting must be adjusted accordingly. To determine the torque wrench setting or indication with adapter installed reference Figure 20-01.

TITLE:
Air Conditioning System Installation Instructions For Continued Airworthiness for Airbus Helicopters AS-350 B, C, D, D1, B1, B2, B3, BA & EC-130 B4

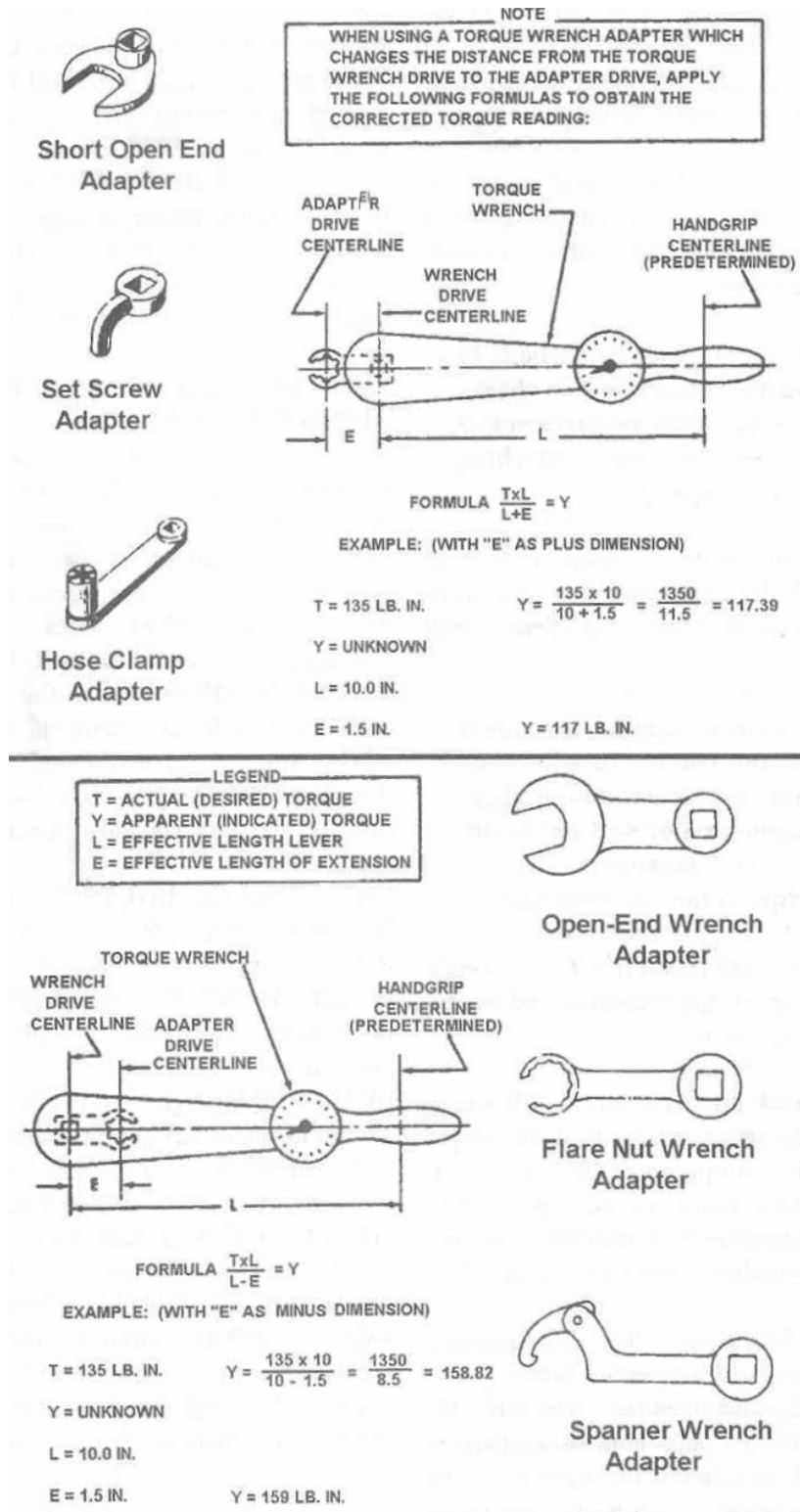

Figure 20 - 1: Torque Wrenches and Adapters

2. Torque Values

Warning: Do not exceed maximum allowable torque value. Overstressing of fastener may result.

Standard hardware torque values are given in the following [Table 20 - 1](#) through [Table 20 - 3](#). [Table 20 - 1](#) gives recommended torque values for fine thread fasteners, shear and tension applications. [Table 20 - 2](#) gives recommended torque values for coarse thread fasteners, shear and tension applications. [Table 20 - 3](#) gives recommended torque values for Phillips-head screws.

Table 20 - 1: Recommended Torque Values for Fine-Thread Fasteners

Thread Size Fractional (decimal)	Shear		Tension	
	Recommended in-lb (N-m)	Maximum in-lb (N-m)	Recommended in-lb (N-m)	Maximum in-lb (N-m)
8-36 (0.1640-36)	7-9 (0.79-1.02)	12 (1.36)	12-15 (1.36-1.69)	20 (2.26)
10-32 (0.1900-32)	12-15 (1.36-1.69)	25 (2.82)	20-25 (2.25-2.82)	40 (4.51)
1/4-28 (0.2500-28)	30-40 (3.38-4.51)	60 (6.77)	50-70 (5.64-7.90)	100 (11.29)
5/16-24 (0.3125-24)	60-85 (6.77-9.60)	140 (15.81)	100-140 (11.29-15.81)	225 (25.41)
3/8-24 (0.3750-24)	95-110 (10.73-12.42)	240 (27.11)	160-190 (18.07-21.46)	390 (44.05)
7/16-20 (0.4375-20)	270-300 (30.49-33.88)	500 (56.48)	450-500 (50.83-56.48)	840 (94.88)
1/2-20 (0.5000-20)	290-410 (32.75-46.31)	660 (74.55)	480-690 (54.22-77.94)	1,100 (124.25)
9/16-18 (0.5625-18)	480-600 (54.22-67.77)	960 (108.44)	800-1,000 (90.36-112.96)	1,600 (180.73)
5/8-18 (0.6250-18)	660-780 (74.55-88.10)	1,400 (158.14)	1,100-1,300 (124.25-146.84)	2,400 (271.10)
3/4-16 (0.7500-16)	1,300-1,500 (146.84-169.44)	3,000 (338.88)	2,300-2,500 (259.80-282.40)	5,000 (564.80)
7/8-14 (0.8750-14)	1,500-1,800 (169.44-203.32)	4,200 (474.43)	2,500-3,000 (282.40-338.88)	7,000 (790.72)
1-12 (1.0000-12)	2,200-3,300 (248.51-372.76)	6,000 (677.76)	3,700-5,500 (417.95-621.28)	10,000 (1129.6)
1-1/8-12 (1.1250-12)	3,000-4,200 (338.88-474.43)	9,000 (1016.6)	5,000-7,000 (564.80-790.72)	15,000 (1694.4)
1-1/4-12 (1.2500-12)	5,400-6,600 (609.98-745.53)	15,000 (1694.4)	9,000-11,000 (1016.6-1242.6)	25,000 (2824.0)



TITLE:
Air Conditioning System Installation Instructions For Continued Airworthiness for Airbus Helicopters AS-350 B, C, D, D1, B1, B2, B3, BA & EC-130 B4

Table 20 - 2: Recommended Torque Values for Coarse-Thread Fasteners

Thread Size Fractional (decimal)	Shear		Tension	
	Recommended in-lb (N-m)	Maximum in-lb (N-m)	Recommended in-lb (N-m)	Maximum in-lb (N-m)
8-32 (0.1640-32)	7-9 (0.79-1.02)	12 (1.36)	12-15 (1.36-1.69)	20 (2.26)
10-24 (0.1900-24)	12-15 (1.36-1.69)	21 (2.37)	20-25 (2.25-2.82)	35 (3.95)
1/4-20 (0.2500-20)	25-30 (2.82-3.38)	45 (5.08)	40-50 (4.51-5.64)	75 (8.47)
5/16-18 (0.3125-18)	48-55 (5.42-6.21)	100 (11.29)	80-90 (9.03-10.16)	160 (18.07)
3/8-16 (0.3750-16)	95-100 (10.73-11.29)	170 (19.20)	160-185 (18.07-20.89)	275 (31.06)
7/16-14 (0.4375-14)	140-155 (15.81-17.50)	280 (31.62)	235-255 (26.54-28.8)	475 (53.65)
1/2-13 (0.5000-13)	240-290 (27.11-32.75)	520 (58.73)	400-480 (45.18-54.22)	880 (99.40)
9/16-12 (0.5625-12)	300-420 (33.88-47.44)	650 (73.42)	500-700 (56.48-79.07)	1,100 (124.25)
5/8-11 (0.6250-11)	420-540 (47.44-60.99)	900 (101.66)	700-900 (79.07-101.66)	1,500 (169.44)
3/4-10 (0.7500-10)	700-950 (79.07-107.31)	1,500 (169.44)	1,150-1,600 (129.90-180.73)	2,500 (282.40)
7/8-9 (0.8750-9)	1,300-1,800 (146.84-203.32)	2,700 (474.43)	2,200-3,000 (248.51-338.88)	4,600 (519.61)
1-8 (1.0000-8)	2,200-3,000 (248.51-338.88)	4,500 (508.32)	3,700-5,000 (417.95-564.80)	7,600 (858.49)
1-1/8-8 (1.1250-8)	3,300-4,000 (372.76-451.84)	7,200 (813.31)	5,500-6,500 (621.28-734.24)	12,000 (1355.5)
1-1/4-8 (1.2500-8)	4,000-5,000 (451.84-564.80)	10,000 (1129.6)	6,500-8,000 (734.24-903.68)	16,000 (1807.4 N m)



DATE:
08/04/2023

DOC No.:
IFSE-0007

REV:
F-1

PAGE:
36 of 99

TITLE:
Air Conditioning System Installation Instructions For Continued
Airworthiness for Airbus Helicopters AS-350 B, C, D, D1, B1, B2, B3, BA &
EC-130 B4

Table 20 - 3: Recommended Torque Values for Phillips-Head Fasteners

Thread Size Fractional (decimal)	Recommended in-lb (N-m)	Maximum in-lb (N-m)
8-32 (0.1640-32)	12-15 (1.36-1.69)	23 (2.59)
10-32 (0.1900-32)	20-25 (2.25-2.82)	35 (3.95)
1/4-28 (0.2500-28)	60-70 (6.77-7.90)	90 (10.16)
5/16-24 (0.3125-24)	110-125 (12.42-14.12)	150 (16.94)
3/8-24 (0.3750-24)	150-175 (16.94-19.76)	225 (25.41)
7/16-20 (0.4375-20)	230-280 (25.98-31.62)	450 (50.83)
1/2-20 (0.5000-20)	550-650 (62.12-73.42)	850 (96.01)
9/16-18 (0.5625-18)	750-900 (84.72-101.66)	1,200 (135.55)
5/8-18 (0.6250-18)	1,100-1,300 (124.25-146.84)	1,600 (180.73)



DATE:
08/04/2023

DOC No.:
IFSE-0007

REV:
F-1

PAGE:
37 of 99

TITLE:
Air Conditioning System Installation Instructions For Continued
Airworthiness for Airbus Helicopters AS-350 B, C, D, D1, B1, B2, B3, BA &
EC-130 B4

Section 20-30-00 Painting Maintenance Practices

The following procedures should be used to touch-up paint flaking, scratches, nicks, and gouges in system components.

Warning: Cleaning solvents and epoxy primer are flammable. Cleaning solvents, epoxy primer, and alodine can cause burns and irritation when skin is contacted. Vapors are harmful and caustic to eyes; goggles must be worn for eye protection. Cleaning solvents and alodine are poisonous. Vapors are harmful to life or health; work should be performed with proper ventilation and / or respirators should be worn while working with cleaning solvents, epoxy primer and alodine.

1. Paint Touch-Up of Small Areas

Use the following procedures to touch-up paint of small sanded areas and nicks, scratches, gouges, etc., that do not go through paint and primer to bare metal.

- a. Wipe surface clean with trichloroethane, MIL-T-81533, or equivalent cleaning solvent, and wipe dry immediately.
- b. Apply coat of epoxy polyamide primer, MIL-P-23377F or equivalent, to match original. Feather primer coating onto surrounding color coat. Allow primer to air dry for 30 minutes.
- c. Apply topcoat to match original finish.

Section 20-40-00 Corrosion Control Maintenance Practices

1. Corrosion Control

The system components are fabricated primarily of steel and aluminum, and should be inspected regularly for any signs of corrosion. The following procedures should be used for removing corrosion and treating affected areas.

2. Corrosion Removal

Remove corrosion by either chemical or mechanical means.

a) Paint Removal, Chemical

Caution: Do not use chemical paint stripper on composite materials. Chemical paint strippers can cause composite components to de-bond and / or lose adhesion of the epoxy matrix.

- (1) Mask all non-metallic surfaces in area to be stripped as well as areas where solution may get entrapped.

Warning: Paint stripper can cause burns and irritation when it contacts skin; proper gloves should be worn. Vapors are harmful and caustic to eyes; goggles must be worn for eye protection. Paint stripper is poisonous. Vapors are harmful to life or health; work should be performed with proper ventilation and / or respirators should be worn while working with paint stripper.

- (2) Using a fiber brush, apply sufficient paint stripper (Turco 5873) to cover area of removal.

Note: If paint stripper evaporates quickly or works slowly, cover area with plastic sheet.

- (3) Allow paint remover to remain on surface for a time sufficient to cause wrinkling and lifting of paint (about 10-30 minutes).
- (4) Using non-metallic scraper or abrasive pads (3M Scotchbrite 63) scrub area to further loosen paint.
- (5) Reapply paint stripper (Turco 5873) as necessary in areas where paint remains tightly adherent.

(6) Wash and scrub surface with demineralized water and alkaline cleaner to neutralize paint stripper.

(7) Remove masking materials and any residual paint or stripper

(8) Rinse with demineralized water.

b) Paint Removal, Mechanical

Caution: Do not sand into or expose composite fibers. Do not remove more material than necessary. Do not use aluminum oxide abrasive materials on epoxy/graphite materials.

Use abrasive flap wheel, abrasive disk, abrasive paper, or plastic media blast to remove paint.

c) Corrosion Removal

Note: Aircraft shall be electrically grounded during corrosion removal operations. When removing exterior corrosion from electronic boxes, the unit case shall be electrically grounded during the complete operation.

(1) Corrosion shall be removed by the mildest method possible.

(a) Hand scrub with dry non-metallic brush/pad (3M pad).

(b) Use abrasive cloth (Aluminum oxide 240 grit). Caution: Do not use on epoxy/graphite materials.

(c) Use 320-grit sandpaper.

(d) Glass bead blast.

(e) Use 240-grit abrasive wheel.

Note: On high-strength steel, do not use power tools other than a flap brush or mandrel with abrasive material; overheating and notching may occur.

(2) Ensure all active corrosion and corrosion products have been removed.

(3) Using 320-grit sandpaper, blend edges of paint (if applicable) surrounding repair area to create a smooth transition. Vacuum the area thoroughly to remove all contaminants.

(4) Apply aluminum surface treatment if applicable. (Ref. Section 4 of 20-40-00, Aluminum Alloy Surface Touch-Up Treatment).

(5) Touch-up primer and paint to match original.

3. Mechanical Defects (Nicks, Scratches, Gouges, Etc.)

- a) Section 20-30-00 Painting Maintenance Practices).
- b) If damage is through the paint surface, prepare area for paint touch-up using the following methods.

Note: On high-strength steel, do not use power tools other than a flap brush or mandrel with abrasive material; overheating and notching may occur.

- (1) Remove defect using flap wheel, abrasive disk, abrasive paper, or plastic media blast.
- (2) Using 320-grit sandpaper, blend edges of paint surrounding repair area to create a smooth transition.
- (3) Apply aluminum surface treatment if applicable. (Ref. Section 4 of 20-40-00, Aluminum Alloy Surface Touch-Up Treatment).
- (4) Touch-up primer and paint to match original.

4. Aluminum Alloy Surface Touch-Up Treatment

Note: If there is any question as to whether or not the protective coating is removed, surface treatment shall be applied.

Warning: Alodine and solvents can cause burns and irritation when it contacts skin; proper gloves should be worn. Vapors are harmful and caustic to eyes; goggles must be worn for eye protection. Alodine is poisonous. Vapors are harmful to life or health; work should be performed with proper ventilation and / or respirators should be worn while working with solvents and alodine. Solvent cleaners are flammable.

- a) Scuff surface using 3M Scotchbrite 63 cellulose/nylon scouring pad.
- b) Wipe exposed surface with isopropyl alcohol or aliphatic naphtha. Allow area to air dry for 10 minutes. Do not touch or otherwise contaminate surface after solvent wipe.



DATE:
08/04/2023

DOC No.:
IFSE-0007

REV:
F-1

PAGE:
41 of 99

TITLE:
Air Conditioning System Installation Instructions For Continued
Airworthiness for Airbus Helicopters AS-350 B, C, D, D1, B1, B2, B3, BA &
EC-130 B4

- c) Apply Alodine 1200 or equivalent with cotton swab, non-metallic brush, or by dipping. Maintain moist surface for 1-3 minutes with repeated application. Surface will become amber or brown in color.
- d) Irrigate surface with demineralized or distilled water to remove surface treatment chemical. Allow to air dry for approximately 1 hour.
- e) If there is any surface without color change, repeat procedure.
- f) Apply paint touch-up as required (Ref Section 20-30-00 Painting Maintenance Practices).

Section 20-50-00 Mechanical Fastener Sealing Methods

Remove existing cracked, chipped or broken existing sealing compound and thoroughly clean with solvent. Reseal using MIL-S-8802, sealing compound, mixing per manufacturer's instructions.

Seal mechanical fasteners as shown:

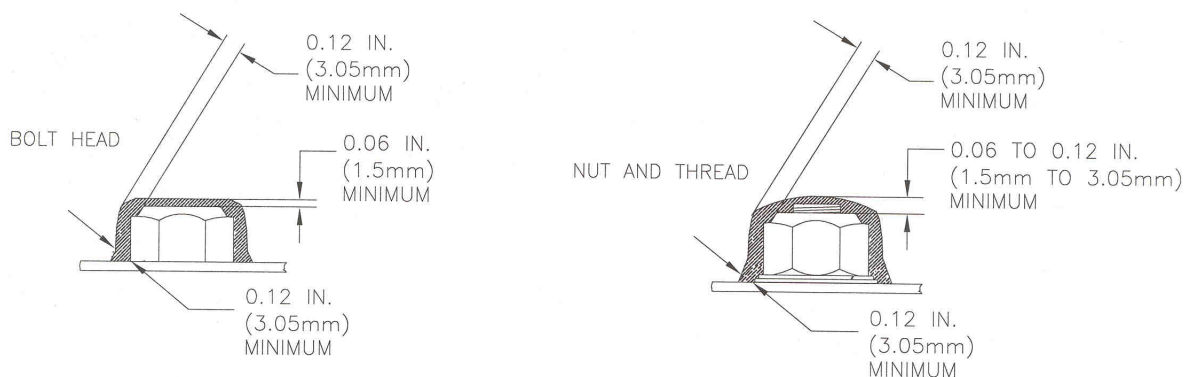

Figure 20 - 02: Mechanical Fastener Sealing

Section 20-90-00 Dye-Penetrant Inspection Methods

Warning: solvents can cause burns and irritation when it contacts skin; proper gloves should be worn. Vapors are harmful and caustic to eyes; goggles must be worn for eye protection. Vapors are harmful to life or health; work should be performed with proper ventilation and / or respirators should be worn while working with solvents. Solvent cleaners are flammable.

Use the following steps to perform dye-penetrant inspection:

1. Using cleaning solvent trichloroethane, MIL-T-81533, clean area to be inspected.
Note: Parts to be inspected must be dry and heated to at least 70° F (21.1° C), but not over 130° F (54.4° C).
Note: Manufacturer's instructions on Dye-Penetrant Kit take precedence over the following instructions.
2. Apply penetrant from dye-penetrant kit (ASTM E1417) by brushing, spraying, or by dipping. Allow to stand for a minimum of 2 minutes.
3. Remove excess penetrant with remover (available with dye-penetrant kit), or by cleaning with plain water. Allow part to dry.
4. Apply a light, even layer of developer from dye-penetrant kit by brushing, spraying, or by dipping. When dipping, avoid excess quantity.
5. Penetrant which has penetrated into cracks (or other openings) in the surface of the part will be drawn out by the developer, resulting in a bright red indication.
6. If part is serviceable or repairable, clean part free of penetrant and developer with trichloroethane (MIL-T-81533) cleaning solvent.

Chapter 21

Section 21-00-00 Air Conditioning

1. Description and Operation

The Air Conditioning System Installation consists of a belt driven vapor cycle air-conditioning system using R-134a as the refrigerant. The air conditioning system provides for cabin comfort during all operations, both in the ground and in flight. During ground operations when the engines are running, cooling may be provided.

This system consists of 4 major components:

- **Condenser-** The condenser is located in one of two positions depending on kit part number (Ref. table 21.1). The aft mounted condenser (Ref. figure 21-01) is mounted in the tail boom mounted 5 in. above the baggage floor. The side mounted condenser is located in the right baggage compartment (Ref. figure 21-02). The EC-130 condenser is only located in the aft mounted configuration. The aft mounted condenser assembly has two blower motors, whereas the side mounted condenser assembly only has one blower motor.
- **Compressor-** The compressor is located aft and to the left side on main transmission deck. The belt is secured to the outside of the drive shaft, in all configurations. If designated by the kit part number (Ref. tables 21-01 & 21-02), either a smooth pulley compressor or a grooved double V-belt pulley compressor is installed.
- **Aft Evaporator-** The aft evaporator is located on the right-hand upper transmission deck in all configurations.
- **Forward Evaporator-** In the AS-350 series, the forward evaporator is located on the cockpit floor forward of the pilots' controls. In the EC-130 kits, it is located forward of the pedestal and mounted to the pedestal.

Controls for the air conditioning system are located around or in the instrument panel, the specific location depending on the Kit number part as described in tables 21-01 and 21-02. All kits contain a Master Control Selector, which consists of a rocker type switch labeled, "A/C", "OFF" and "FAN." Selecting the "A/C" turns on the system's dual evaporator fans, compressor and condenser blower. The second rocker switch, also included with every kit, is for "HIGH," "MED" and "LOW" evaporator fan speed selection for the forward cockpit. An additional 2 position switch for the aft evaporator fan speed "HI/LOW" is present depending on the kit part numbers and the switch is located per that kit.



DATE:
08/04/2023

DOC No.:
IFSE-0007

REV:
F-1

PAGE:
45 of 99

TITLE:
Air Conditioning System Installation Instructions For Continued Airworthiness for Airbus Helicopters AS-350 B, C, D, D1, B1, B2, B3, BA & EC-130 B4

Table 21-1 Air Condition System Installation Kit Part Number Description AS-350 Series

AS-350 Series	
BASE KIT NUMBERS:	
350-00-011-HP	AEC Basic Configuration Side Mounted Condenser (Ref Figure 21-01)
350-00-031-HP	AEC Basic Configuration Aft Mounted Condenser (Ref Figure 21-02)

Table 21-2 Air Condition System Installation Kit Part Number Description EC-130 Series

EC-130B4	
BASE KIT NUMBER:	
130-00-031-HP*	Aft Mounted Condenser (Ref Figure 21-02)
CUSTOM CONFIGURATIONS:	
Corporate Configuration (Ref Figure 21-05)	

TITLE:
Air Conditioning System Installation Instructions For Continued
Airworthiness for Airbus Helicopters AS-350 B, C, D, D1, B1, B2, B3, BA &
EC-130 B4

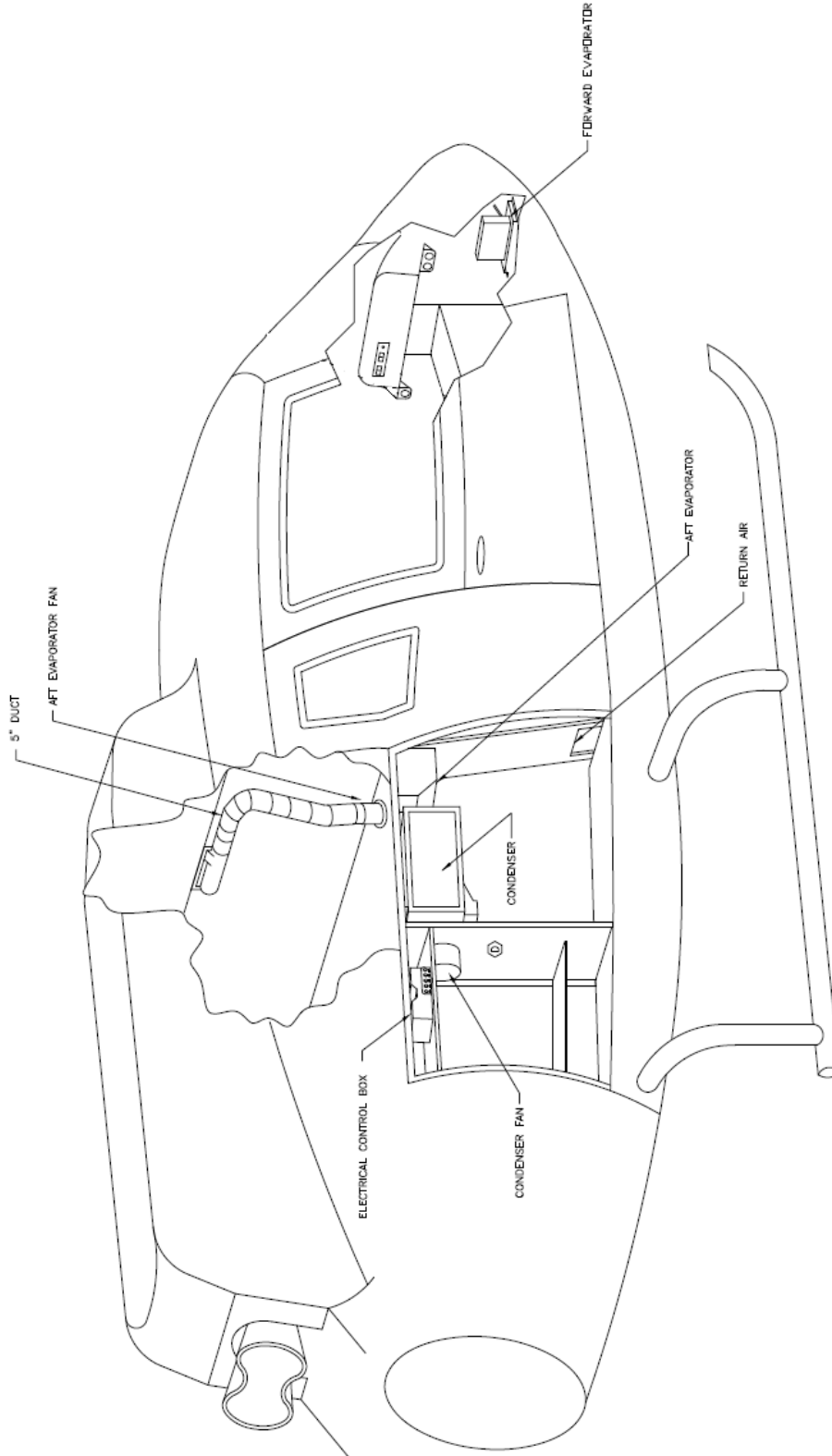

Figure 21-01: Equipment Locations for Air Conditioning System
with the -011 Configuration (Side Mounted Condenser)

TITLE:
Air Conditioning System Installation Instructions For Continued
Airworthiness for Airbus Helicopters AS-350 B, C, D, D1, B1, B2, B3, BA &
EC-130 B4

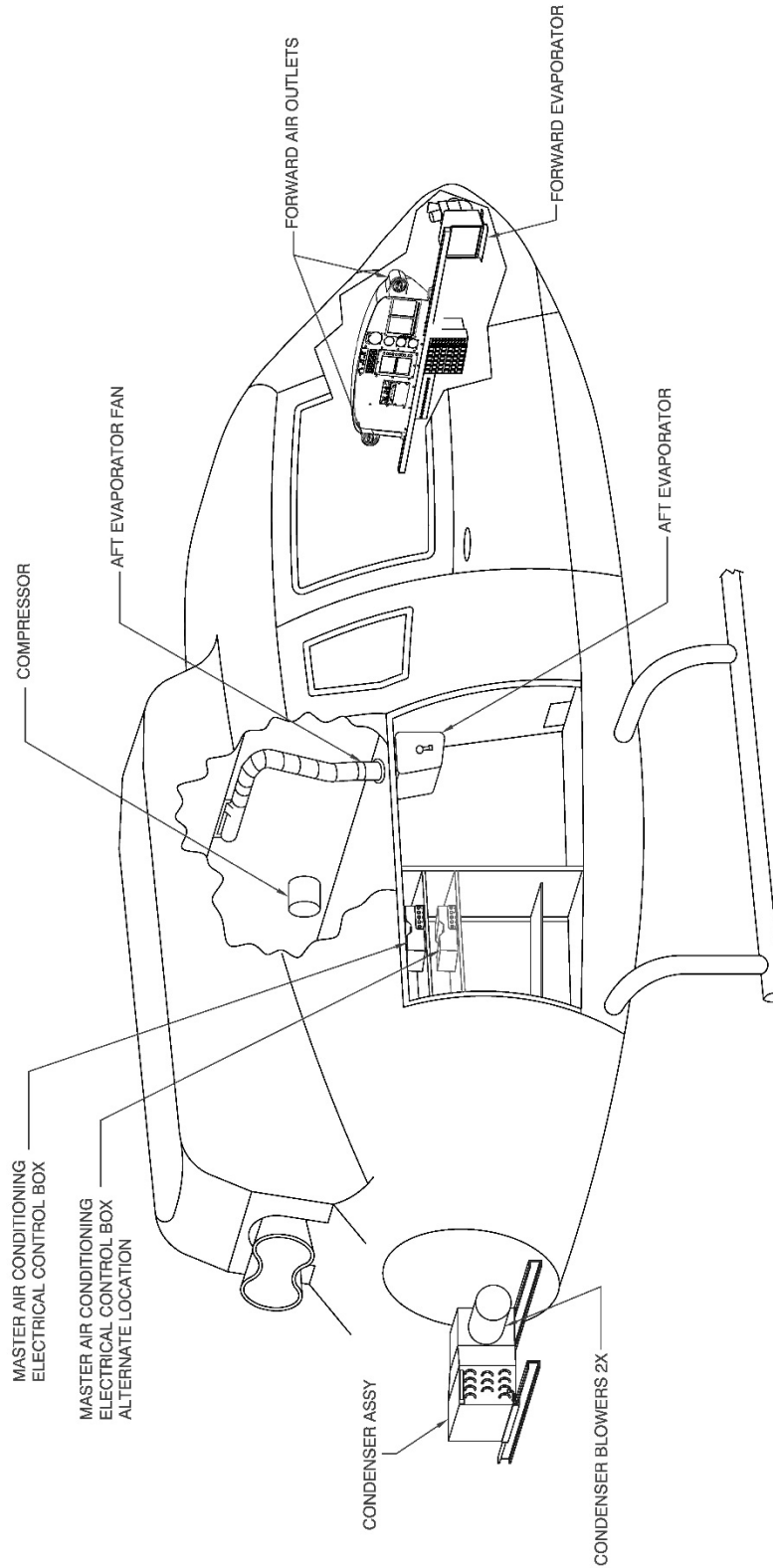
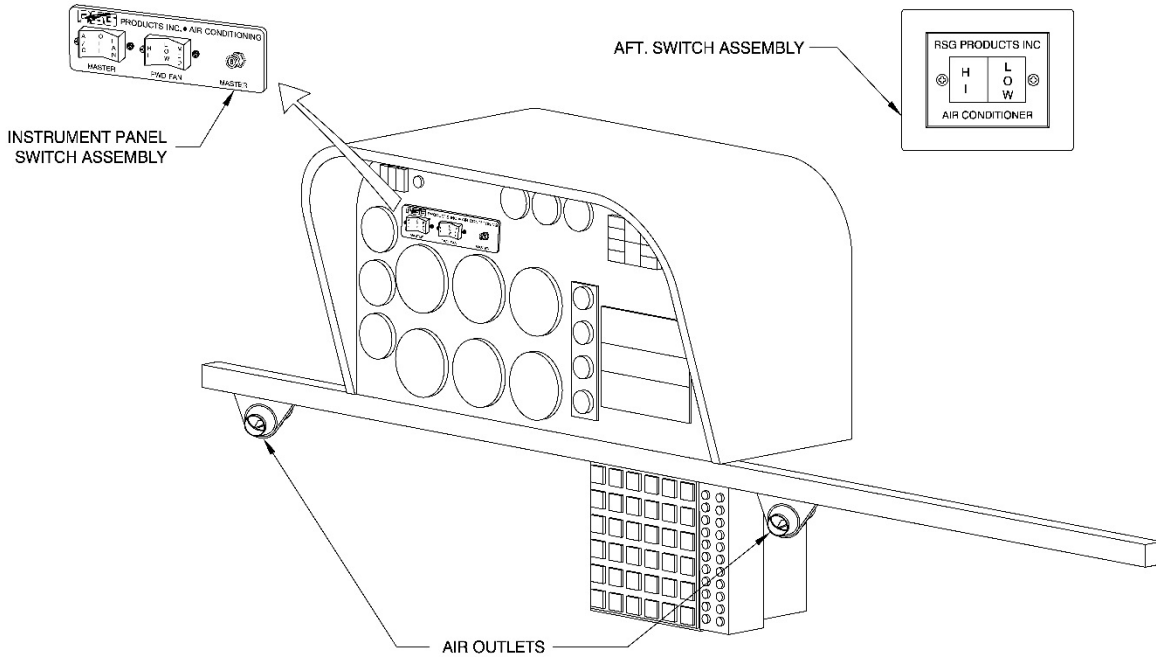
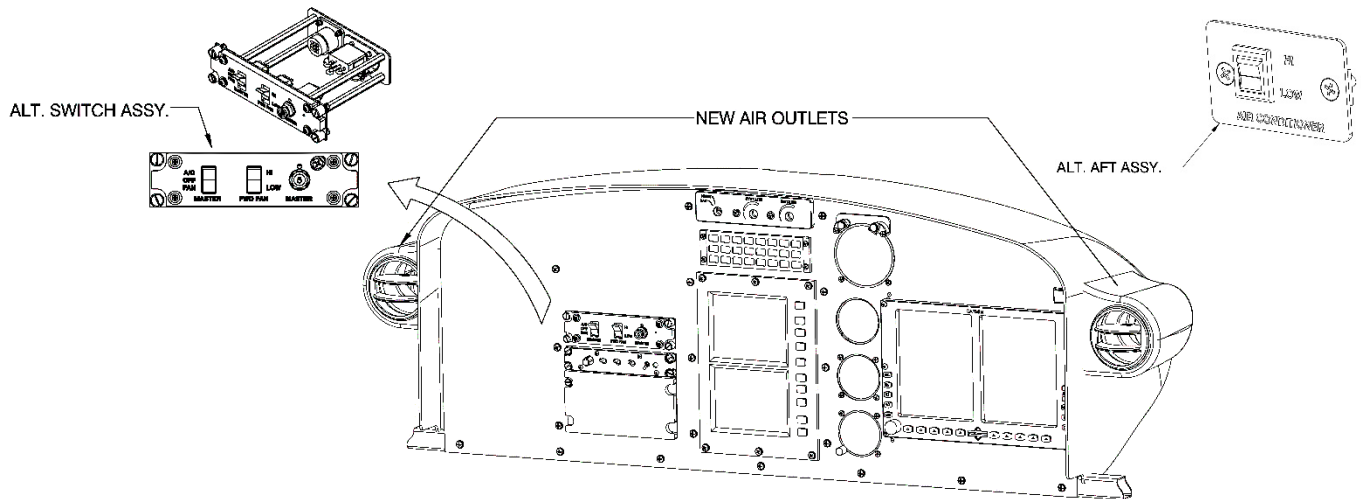

Figure 21-02: Equipment Locations for Air Conditioning System with the -031 Configuration (Aft Mounted Condenser)

TITLE:
Air Conditioning System Installation Instructions For Continued
Airworthiness for Airbus Helicopters AS-350 B, C, D, D1, B1, B2, B3, BA &
EC-130 B4



(AS350 Old configuration)



(AS350 New configuration)

Figure 21 - 03: AEC Basic Configuration
(Top - Old config. / Bottom - New config.)

TITLE:
Air Conditioning System Installation Instructions For Continued
Airworthiness for Airbus Helicopters AS-350 B, C, D, D1, B1, B2, B3, BA &
EC-130 B4

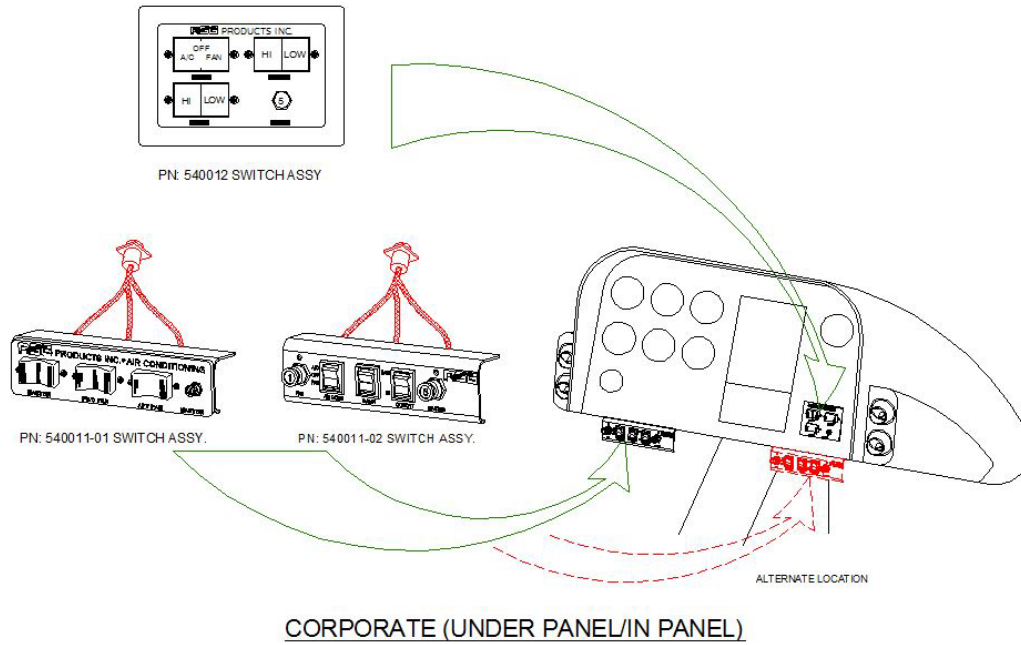

Figure 21 - 05: Corporate Configuration (EC130)

2. **Removal/ Installation Forward Evaporator**

(Ref. figures 21-06 and 21-07)

a) **Removal**

- 1) Access forward evaporator per Section 6-00-00 Dimensions and Access.
- 2) Connect refrigerant reclaimer to system in accordance with Section 21-00-00 and remove coolant from system. Comply with all Federal, State, and Local rules governing refrigerant handling.
- 3) Remove bolts securing evaporator.
- 4) Remove evaporator assembly.
- 5) Support evaporator while removing lines and other duct work.
- 6) Remove evaporator from aircraft.
- 7) Cap all open lines on unit and aircraft.
- 8) Disconnect electrical connections and remove evaporator fan.

b) **Installation**

- 1) Reinstall fan in aircraft and connect electrical connections.
- 2) Position evaporator against fan assembly and loosely install with securing hardware. Secure mounting hardware.
- 3) Reinstall drain line.
- 4) Connect duct work.
- 5) Ensure refrigerant O-rings are installed and in good condition. Replace as necessary. Oil all O-rings and fittings with refrigerant oil of the same type listed on the compressor. Torque refrigerant lines: #6 11-13 ft./lbs.; #8 15-20 ft./lbs.; #10 21-27 ft./lbs.
- 6) After completing other system functions and maintenance, charge system in accordance with Section 12-10-00.
- 7) Check for leaks per section 12-30-00

TITLE:
Air Conditioning System Installation Instructions For Continued
Airworthiness for Airbus Helicopters AS-350 B, C, D, D1, B1, B2, B3, BA &
EC-130 B4

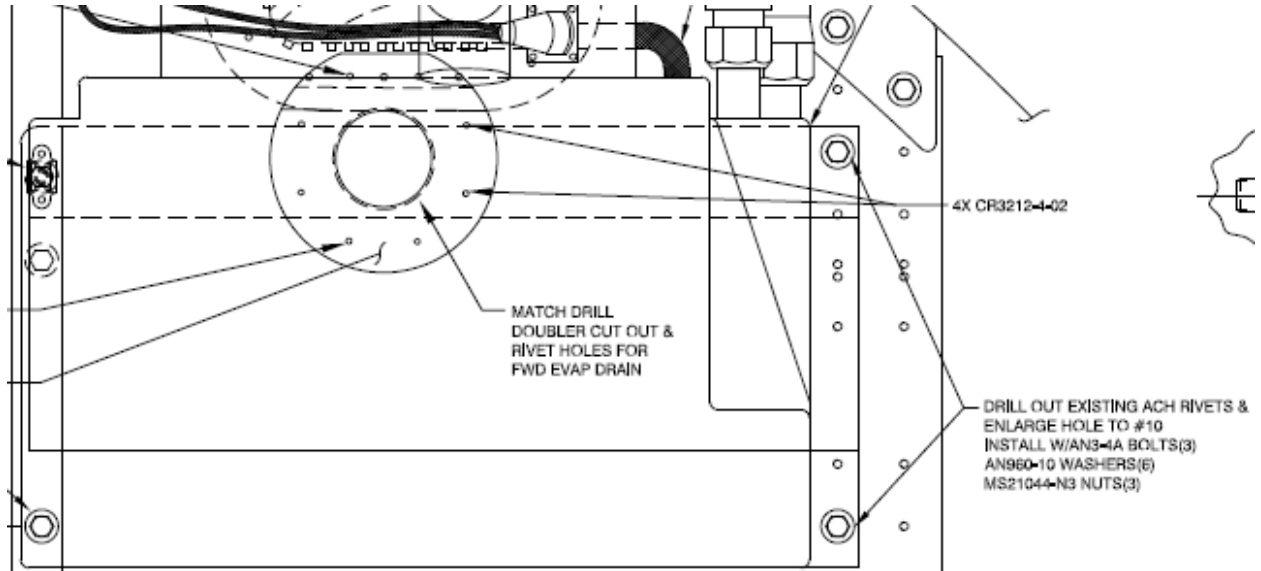

Figure 21 - 06: Forward Evaporator (AS-350)

FLUSH WITH PLATE, AND ATTACH WITH
5X AN3-5A BOLT
5X AN960-10 WASHER

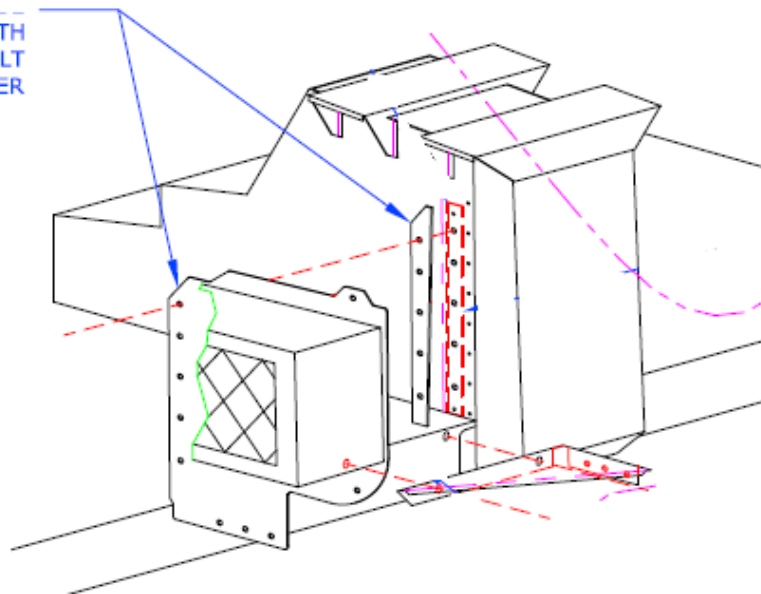

Figure 21 - 07: Forward Evaporator (EC-130)

3. Removal/ Installation Aft Evaporator

(Ref Figure 21-08)

a) Removal

- 1) Access aft evaporator (Ref. Section 6-00-00 Dimensions and access) and remove electrical connections.
- 2) Reclaim refrigerant in system in accordance with Section 12-10-00, to remove coolant from system.
- 3) Support evaporator while removing lines and duct work.
- 4) Cap all open lines on unit and aircraft.

b) Installation

- 1) Reinstall fan/evaporator and connect electrical connections.
- 2) Position evaporator and loosely install with securing hardware. Secure mounting hardware.
- 3) Reinstall drain line.
- 4) Connect duct work.
- 5) Ensure refrigerant O-rings are installed and in good condition. Replace as necessary. Oil all O-rings and fittings with refrigerant oil of the same type listed on the compressor. Torque refrigerant lines: #6 11-13 ft./lbs.; #8 15-20 ft./lbs.; #10 21-27 ft./lbs.
- 6) After completing other system functions and maintenance, charge system in accordance with Section 12-10-00.
- 7) Check for leaks per section 12-30-00.

TITLE:
Air Conditioning System Installation Instructions For Continued Airworthiness for Airbus Helicopters AS-350 B, C, D, D1, B1, B2, B3, BA & EC-130 B4

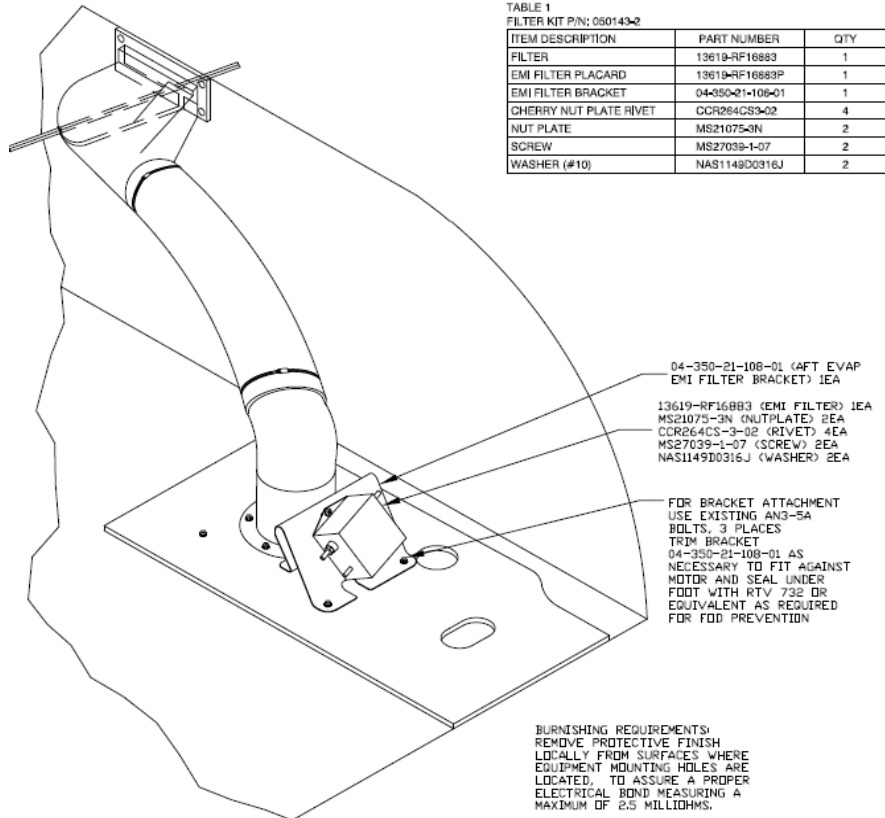

Figure 21 - 08: Aft Evaporator

4. Removal / Installation - Condenser

(Ref figures 21-09 and 21-10)

a) Removal

- 1) Access the condenser (Ref Section 6-00-00 Dimensions and Access)
- 2) Reclaim refrigerant in system in accordance with Section 12-10-00, to remove coolant from system.
- 3) Remove hardware securing condenser assembly. Disconnect blower wires and refrigerant hoses.
- 4) Remove condenser and cap all open lines on condenser and airframe.



DATE:
08/04/2023

DOC No.:
IFSE-0007

REV:
F-1

PAGE:
54 of 99

TITLE:
Air Conditioning System Installation Instructions For Continued
Airworthiness for Airbus Helicopters AS-350 B, C, D, D1, B1, B2, B3, BA &
EC-130 B4

b) Installation

- 1) Place condenser back in location.
- 2) Loosely install all hardware securing condenser assembly. Tighten mounting hardware only after all other hardware is installed.
- 3) Remove protective caps from refrigerant lines. Inspect that O-rings are installed and in good condition. Oil all O-rings and fittings with refrigerant oil of the same type listed on the compressor.
- 4) Install refrigerant lines. Torque refrigerant lines as follows: #6 11-13 ft./lbs.; #8 15-20 ft./lbs.; #10 21-27 ft./lbs. Do not over tighten.
- 5) Charge system in accordance with Section 12-10-00
- 6) Install 5" duct P/N: 060004

TITLE:
Air Conditioning System Installation Instructions For Continued
Airworthiness for Airbus Helicopters AS-350 B, C, D, D1, B1, B2, B3, BA &
EC-130 B4

BURNISHING REQUIREMENTS:
REMOVE PROTECTIVE FINISH LOCALLY FROM
SURFACES WHERE EQUIPMENT MOUNTING HOLES
ARE LOCATED, TO ASSURE A PROPER ELECTRICAL
BOND MEASURING A MAXIMUM OF 2.5 MILLIOHMS.

OPTIONAL INSTALL FOR NOISE REDUCTION WHEN BRUSHLESS
MOTORS ARE INSTALLED; P/Ns: IFSS 050143 DCB, -1 DCB,
-2 DCB, AND -3 DCB.
INSTALL THE FOLLOWING, MAINTAINING BURNISHING REQ:
13619-RF16883 (EMI FILTER) 2EA
MS27039-0807 (SCREW) 4EA
NAS620-8L (WASHER) 4EA

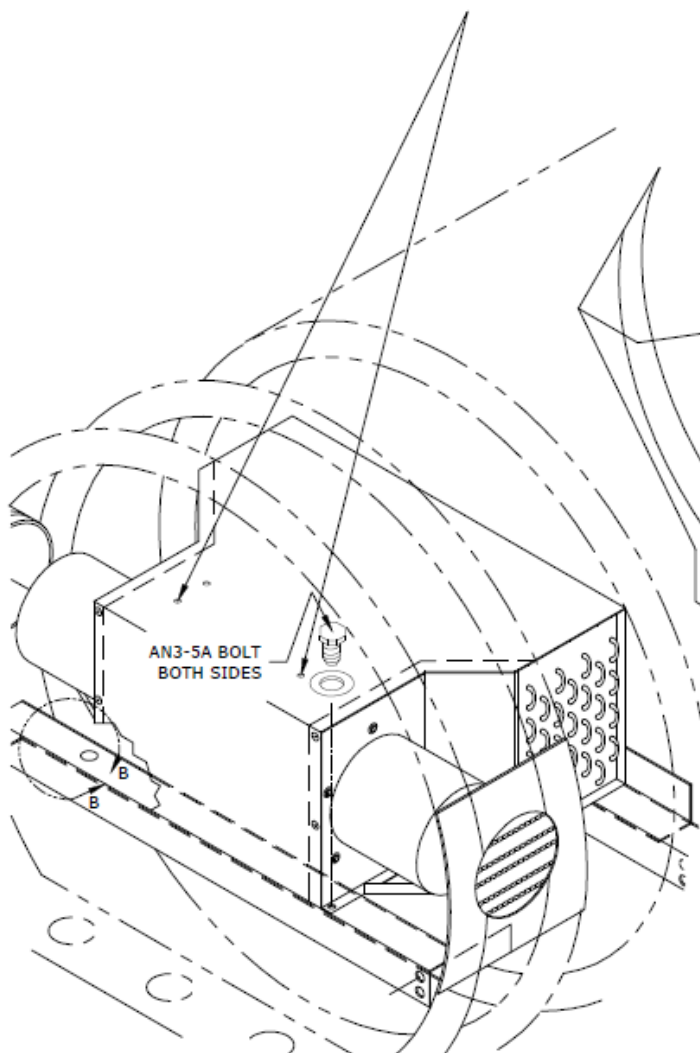

Figure 21 - 09: Aft Mounted Condenser (AS-350, EC-130)

TITLE:
Air Conditioning System Installation Instructions For Continued
Airworthiness for Airbus Helicopters AS-350 B, C, D, D1, B1, B2, B3, BA &
EC-130 B4

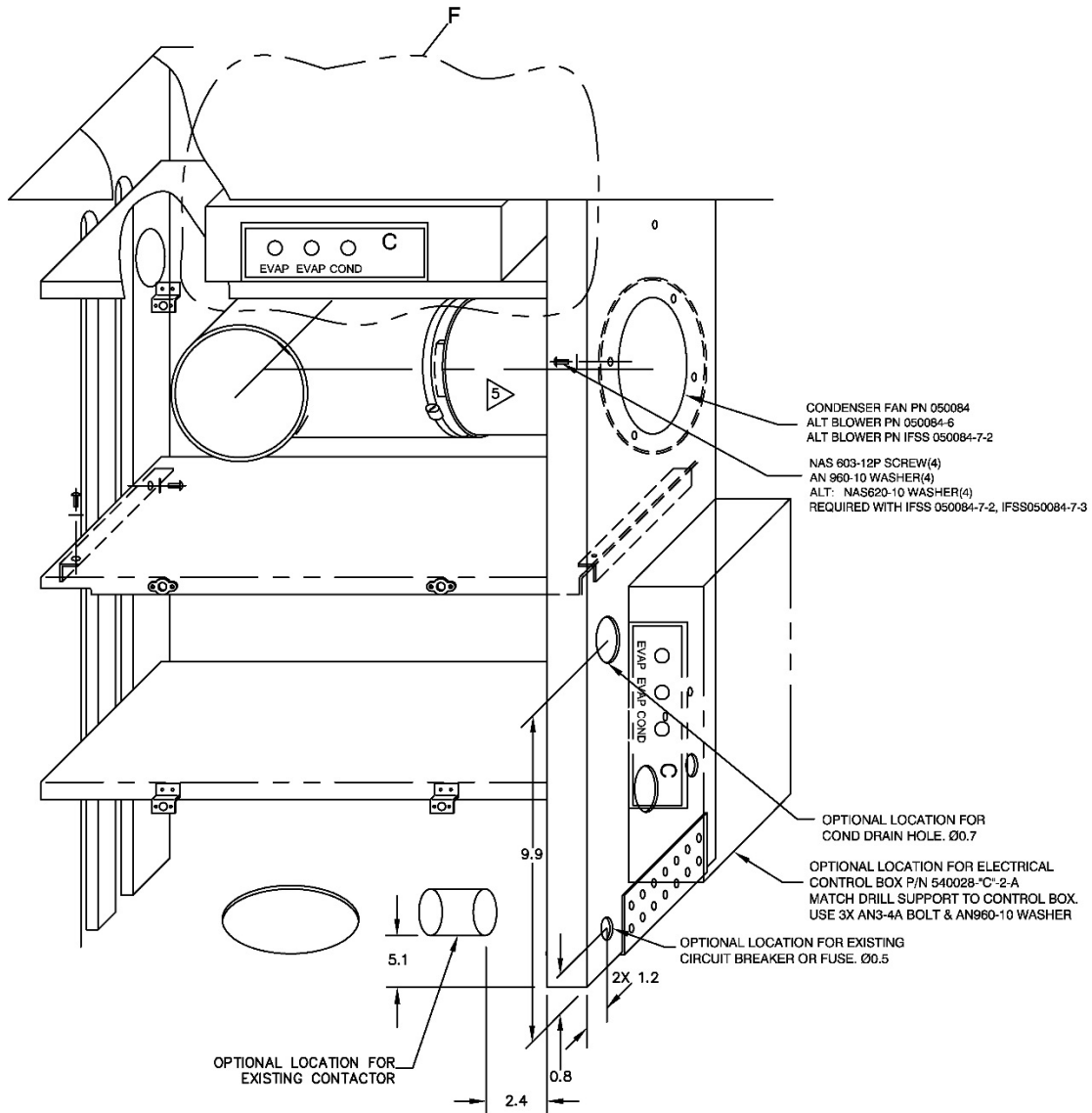

Figure 21 - 10: Side Mounted Condenser (AS-350)

5. Removal / Installation - Compressor

(Ref figure 21-11)

a) Removal

- 1) Access the compressor (Ref Section 6-00-00 Dimensions and Access)
- 2) Reclaim refrigerant in system in accordance with Section 12-10-00, to remove coolant from system.
- 3) Remove refrigerant lines from compressor and install protective caps to protect from foreign material entering system and compressor.
- 4) Disconnect drive belt to compressor.
- 5) Remove bolts securing compressor to mount and remove compressor.

b) Installation

- 1) Install compressor loosely on support frame with attaching hardware.
- 2) Install drive belt.
- 3) Tighten compressor bolts allowing compressor to "Seek" its own natural position on the frame. Tighten compressor belt tensioning bolt to 50 lbs. belt tension for PN 060018-1 Flat Belt, or 30 lbs. tension for PN 060005 Grooved Belt.
- 4) Tighten and safety all compressor mounting bolts.
- 5) Remove protective caps from refrigerant lines and compressor. Inspect the O-rings from installation and condition. Replace as necessary.
- 6) Oil all fittings and O-rings.
- 7) Install refrigerant lines.
- 8) Torque refrigerant lines: #6 11-13 ft./lbs.; #8 15-20 ft./lbs.; #10 21-27 ft./lbs. Do not over tighten.
- 9) Charge system in accordance with Section 12-00-00.
- 10) Install previously removed cowlings.

TITLE:
Air Conditioning System Installation Instructions For Continued
Airworthiness for Airbus Helicopters AS-350 B, C, D, D1, B1, B2, B3, BA &
EC-130 B4

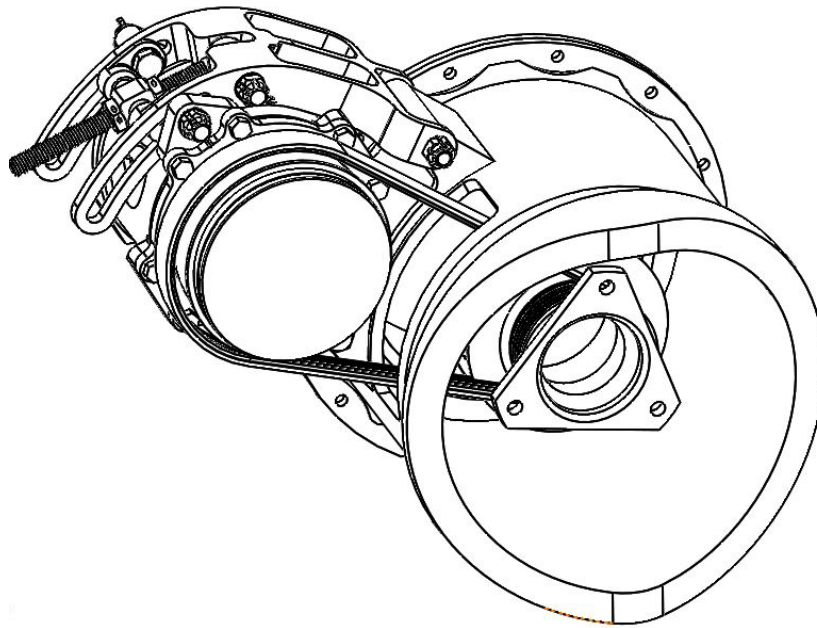

Figure 21 - 11: Compressor

6. Troubleshooting guide

Symptoms	Trouble	Cause	Correction
<ul style="list-style-type: none"> -Insufficient cooling -Low-side pressure too low -High -side pressure too low -Air in ducts only slightly cool 	Low or partial refrigerant charge	Leak	Find and fix the leak. If there was a loss of oil, be sure to check to compressor oil level. Evacuate and recharge per section 12.10.00
<ul style="list-style-type: none"> - Insufficient cooling during hottest part of the day or during extended flying. - Low-side pressure normal, though it may be too low or even a vacuum - High-side pressure normal, though it may be low-at the same time low side is low - Air in the ducts is usually cold, but becomes warm when pressure reading drop 	Excessive moisture in the system	The desiccant in the drier/receiver is saturated	Replace or rebuild the receiver/drier. Evacuate and recharge per section 12.10.00
<ul style="list-style-type: none"> - Insufficient cooling - Low-side pressure normal, but does not drop when the clutch cycles - High-side pressure high - Air in ducts only slight cool 	Air in the System	Refrigerant contains non-condensable in the form of air moisture	Leak test, watch for bad compressor seals. Drain the system. Repair leaks as needed. Replace or rebuild the receiver-drier. Check the compressor oil. Evacuate and recharge per section 12.10.00.
<ul style="list-style-type: none"> - No cooling - Low-side pressure too high - High-side pressure too high - Liquid line very hot - Air in ducts is warm 	Condenser malfunction or system overcharge	Condenser malfunction or system overcharge	Evacuate and recharge per section 12.10.00 or replace condenser.

Section 21-10-00 Illustrated Parts List

1. General

This section contains information on parts for the Air Conditioning System Installation, for use in ordering replacements if necessary.

Air Outlets

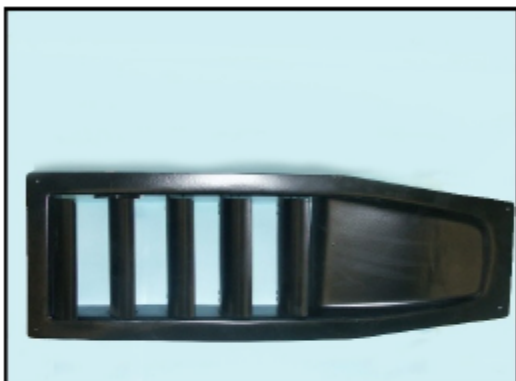

RSG PN: 520071-1
**Condenser Air Intake
Assembly Low Profile
(Sliding Door)**

AS350 



RSG PN: 500001
Left Side Air Outlet

EC130 



RSG PN: 500002
Right Side Air Outlet

EC130 

Air Outlets



RSG PN: 510259-3
Air Outlet Assembly

AS350 

EC130 

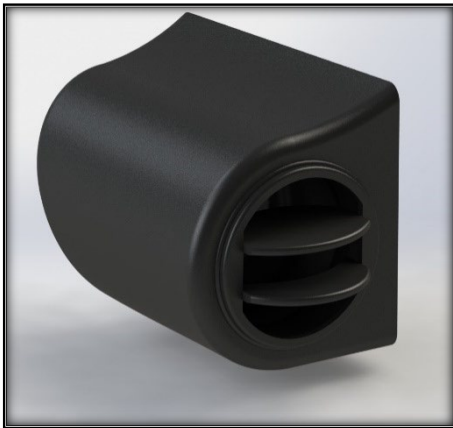

RSG PN: 520156HP-01
Air Outlet L.H.

AS350 

EC130 

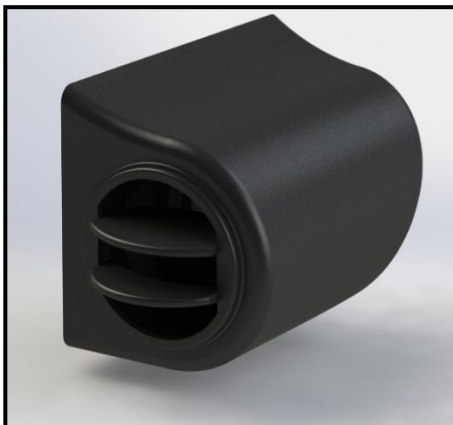

RSG PN: 520157HP-01
Air Outlet R.H.

AS350 

EC130 

Blower Motors



RSG PN:IFSS 050143-2 DCB
-3 DCB

**5" Vane Axial Blower
Assembly**

AS350 

EC130 



RSG PN: 050052-1
**Blower Motor,
Modified Right Half**

AS350 



RSG PN: 490017-1-02
**Aft Evaporator Fan
Assembly**

AS350 

TITLE:
Air Conditioning System Installation Instructions For Continued
Airworthiness for Airbus Helicopters AS-350 B, C, D, D1, B1, B2, B3, BA &
EC-130 B4

Blower Motor Part

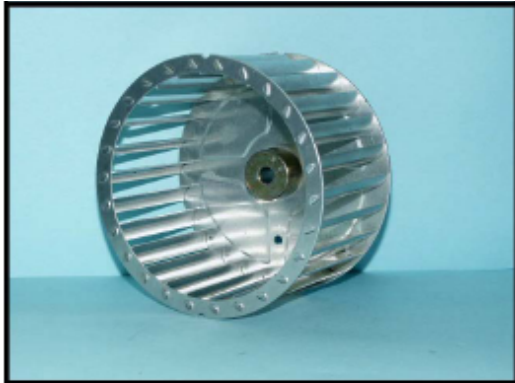

RSG PN: 040004-8
Fan Wheel CW

AS350 

EC130 

Compressors



RSG PN: 590008
**Compressor
Assembly**

AS350 

EC130 

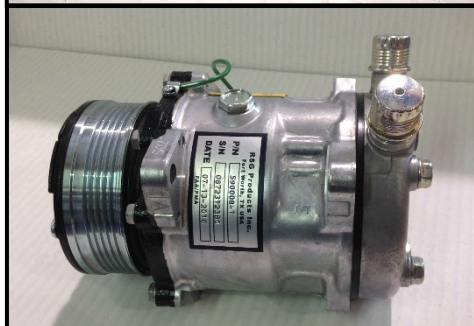

RSG PN: 590008-1
**Compressor
Assembly**

AS350 

EC130 

Compressor Parts



RSG PN: 050033
Coil, 24 VDC

AS350 

EC130 

Compressor Parts



RSG PN: 060005
**24.3" 4 Groove
Serpentine Belt**

AS350 

EC130 



RSG PN: 060018 25-1/4"
RSG PN: 060018-1 25"
Flat Belt

AS350 

EC130 

Compressor Bracket/Parts



RSG PN: 04-130-21-101-01
**Compressor Mount
Bracket**

AS350 

EC130 

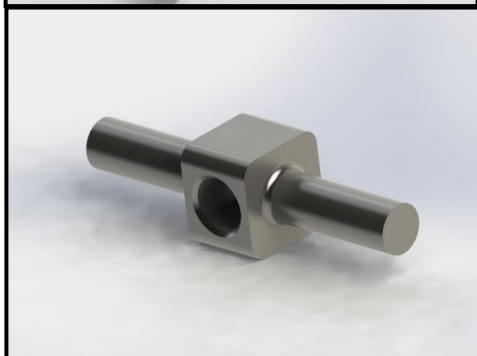

RSG PN: 04-130-21-102-01
**Compressor Mount
Tension Bolt**

AS350 

EC130 

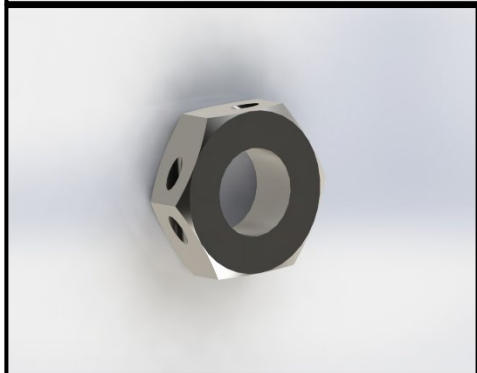

RSG PN: 04-130-21-104-01
Jam Nut Drilled

AS350 

EC130 

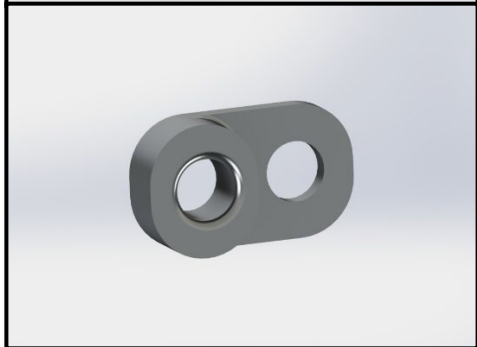

RSG PN: 04-130-21-105-01
Compressor Clamp

AS350 

EC130 

Compressor Bracket/Parts

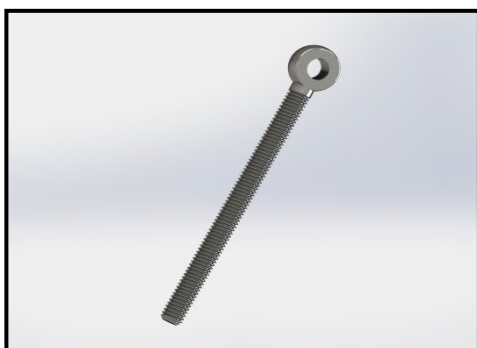

RSG PN: 2434K39
Threaded Rod End

AS350



EC130



RSG PN: 530100-1
**Strap, Housing Mod
Assembly**

AS350



EC130



RSG PN: 300363-2
**Compressor Shim, Upper
(Alt: 261155 not shown)**

AS350



EC130



Compressor Bracket/Parts



RSG PN: 300067-1 Compressor Standoff

AS350 

EC130 



RSG PN: 261007 Bushings, SD507

AS350 

EC130 



RSG PN: 300095 Compressor Pin

AS350 

EC130 

Condenser/Evaporator



RSG PN: 090002-O
Expansion Valve

AS350 

EC130 



RSG PN: 090016-5
Receiver/Drier

AS350 

EC130 



RSG PN: 550003-O
**Aft Condenser
Assembly**

EC130 



RSG PN: 550007-1
**Side Condenser
Assembly**

AS350 

Condenser/Evaporator

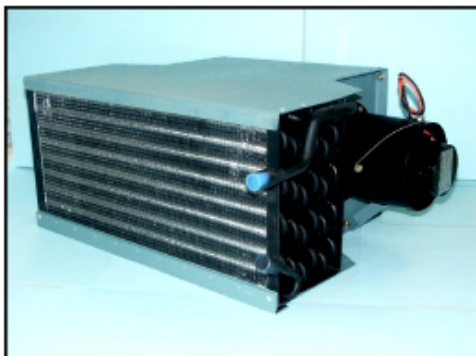

RSG PN: 550022
**Aft Condenser
Assembly**

AS350 



RSG PN: 560004
**Fwd Evaporator
Assembly**

EC130 



RSG PN: 560010-O-5
**Aft Evaporator
Assembly**

AS350 



RSG PN: 560016-O-1
**Aft Evaporator
Assembly**

EC130 

TITLE:
Air Conditioning System Installation Instructions For Continued
Airworthiness for Airbus Helicopters AS-350 B, C, D, D1, B1, B2, B3, BA &
EC-130 B4

Condenser/Evaporator



RSG PN: 56025-O-01

-02

**Fwd Evaporator
Assembly**

AS350 

Electrical Parts



RSG PN: 540009
**Electrical Box
Assembly**

EC130 



RSG PN: 540028-C-1-A
-C-2-A
**Electrical Box
Assembly**

AS350 



RSG PN: 540011-01
-02
**Instrument Panel
Switch**

EC130 



RSG PN: 540044-5
Harness Assembly

AS350 

Electrical Parts



RSG PN: 540044-8-01
-02

**Instrument Panel
Switch**

AS350 



RSG PN: 540044-9
**5 amp Breaker
Assembly**

AS350 

EC130 



RSG PN: 540089-01
-02
**Aft Evaporator Switch
Assembly**

AS350 

Electrical Parts



RSG PN: 050000
Switch with Button

AS350 

EC130 



RSG PN: 050001
Switch without Button

AS350 

EC130 



RSG PN: 050006
Switch without Button

AS350 

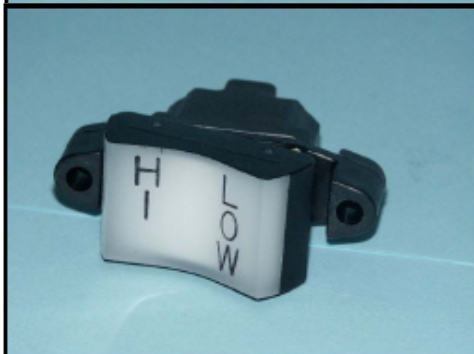

RSG PN: 050006-2
Switch with Button

AS350 

EC130 

Electrical Parts



RSG PN: 050007-1
Button



RSG PN: 050007-3
Button



RSG PN: 050007-4
Button



RSG PN: 050008
Relay

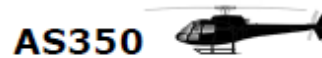

Electrical Parts

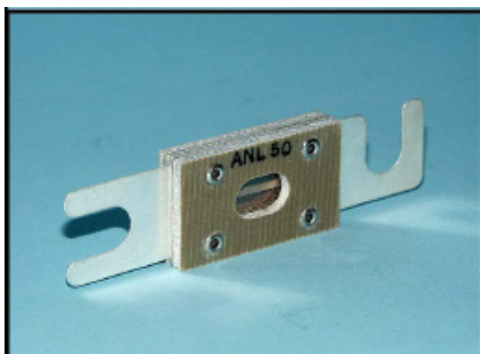

RSG PN: 050015-2
50 Amp Limiter

AS350 

EC130 



RSG PN: 050026
Timer

AS350 

EC130 



RSG PN: 050107
Low Pressure Switch

AS350 

EC130 



RSG PN: 090004
High Pressure Switch

AS350 

EC130 

Electrical Parts

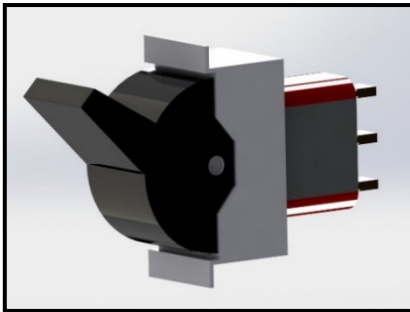

RSG PN: 7303J21ZQI22
Switch, 3PDT, 3 POS.

AS350 

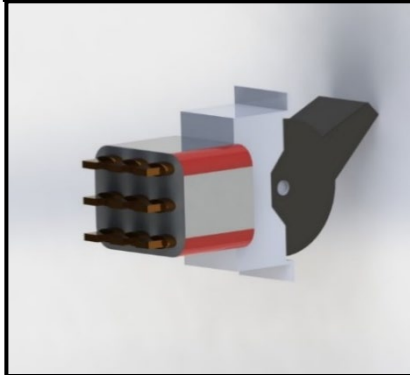

RSG PN: 7301J21ZGE22
Switch, 3PDT, 3 POS.

AS350 

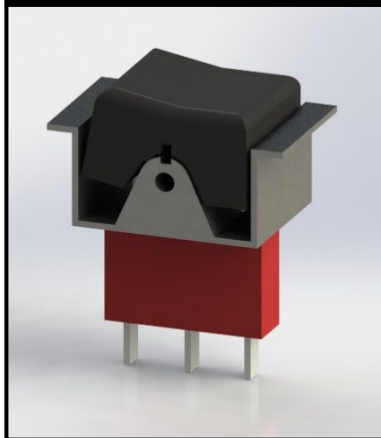

RSG PN: 7301J11ZQE22
Switch, SPST, 2 POS.

AS350 

Electrical Parts

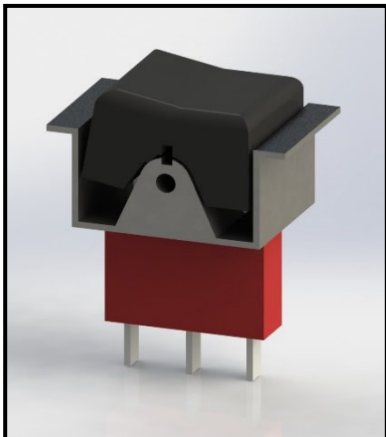

RSG PN: 7101J51ZQE22
Switch, SPST, 2 POS.

EC130 

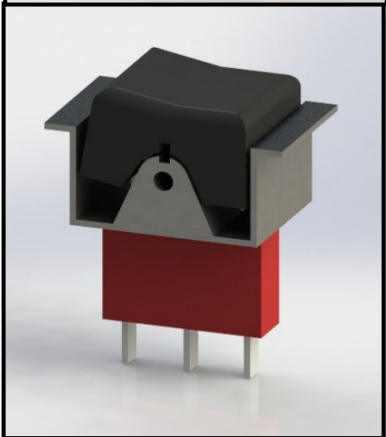

RSG PN: 7203J51ZQE22
Switch, DPDT, 2 POS.

EC130 

EC130 Hoses



RSG PN: 570103
**High Pressure Hose #6
Assembly**

EC130 



RSG PN: 570104
**Condenser to
Receiver/Drier Hose #6
Assembly**

EC130 



RSG PN: 570105
**Return Hose #10
Assembly**

EC130 

AS350 Hoses



RSG PN: 570067-O-A
Hose Assembly #6
Condenser to Drier

AS350 



RSG PN: 570070-O-A-01
Hose Assembly #8
Compressor Discharge

AS350 



RSG PN: 570070-O-A-02
Hose Assembly #8
Compressor Discharge

AS350 



RSG PN: 570020-O-A
Hose Assembly #6
Condenser to Drier

AS350 

AS350 Hoses



RSG PN: 570024-O-A-01
Hose Assembly #8
Compressor Discharge

AS350 



RSG PN: 570024-O-A-02
Hose Assembly #8
Compressor Discharge

AS350 



RSG PN: 570072-O-A
Hose Assembly #6 Fwd
Evaporator to Receiver/Drier

AS350 

AS350 Hoses



RSG PN: 570087-O-A-01
**Hose Assembly Fwd
Evaporator to Aft Evaporator
to Compressor**



RSG PN: 570087-O-A-02
**Hose Assembly Fwd
Evaporator to Aft Evaporator
to Compressor**



BRUSHLESS BLOWER MOTORS



RSG PN: IFSS 050084-7-2
**7" DC Brushless Blower
Assembly Short**

AS350 

EC130 



RSG PN: IFSS 050084-7-3
**7" DC Brushless Blower
Assembly Long**

AS350 

EC130 



TITLE:
Air Conditioning System Installation Instructions For Continued Airworthiness for Airbus Helicopters AS-350 B, C, D, D1, B1, B2, B3, BA & EC-130 B4

LIST OF CONSUMABLE MATERIALS

DESCRIPTION	P/N	VENDOR/SPECIFICATION
THREAD LOCK	242	LOCTITE
ADHESIVE	1300L	3M
Cleaning cloth, Low-Lint	--	Commercial
Mineral Spirits, Cleaning Solvent	--	MIL-PRF-680, TYP II OR ASTM-D235
Alodine	Alodine 1200	--
Alodine	Iridite 14-2	--
Paint Stripper	Turco 5873	--
Polyamide Paint Primer	--	--
Dye Penetrant Kit	--	--
Acetone	--	ASTM-D329
Isopropyl Alcohol	--	TT-I-735
Trichloroethane	--	MIL-T-81533
Nylon Scouring Pad	(3M) Scotchbrite 63	3M
240 Grit Sandpaper	--	Commercial
320 Grit Sandpaper	--	Commercial
240 Grit Aluminum Oxide Abrasive	--	Commercial
Cloth	--	Commercial
Sealant	--	MIL-S-8802
Adhesive transfer tape 950 (2")	70-0060-3057-4	3M
Refrigerant	R134a	--

Chapter 98

Section 98-00-00 Wiring Diagrams and Plumbing Schematics

This section contains all applicable wiring diagrams and plumbing schematics.

TITLE:
Air Conditioning System Installation Instructions For Continued
Airworthiness for Airbus Helicopters AS-350 B, C, D, D1, B1, B2, B3, BA &
EC-130 B4

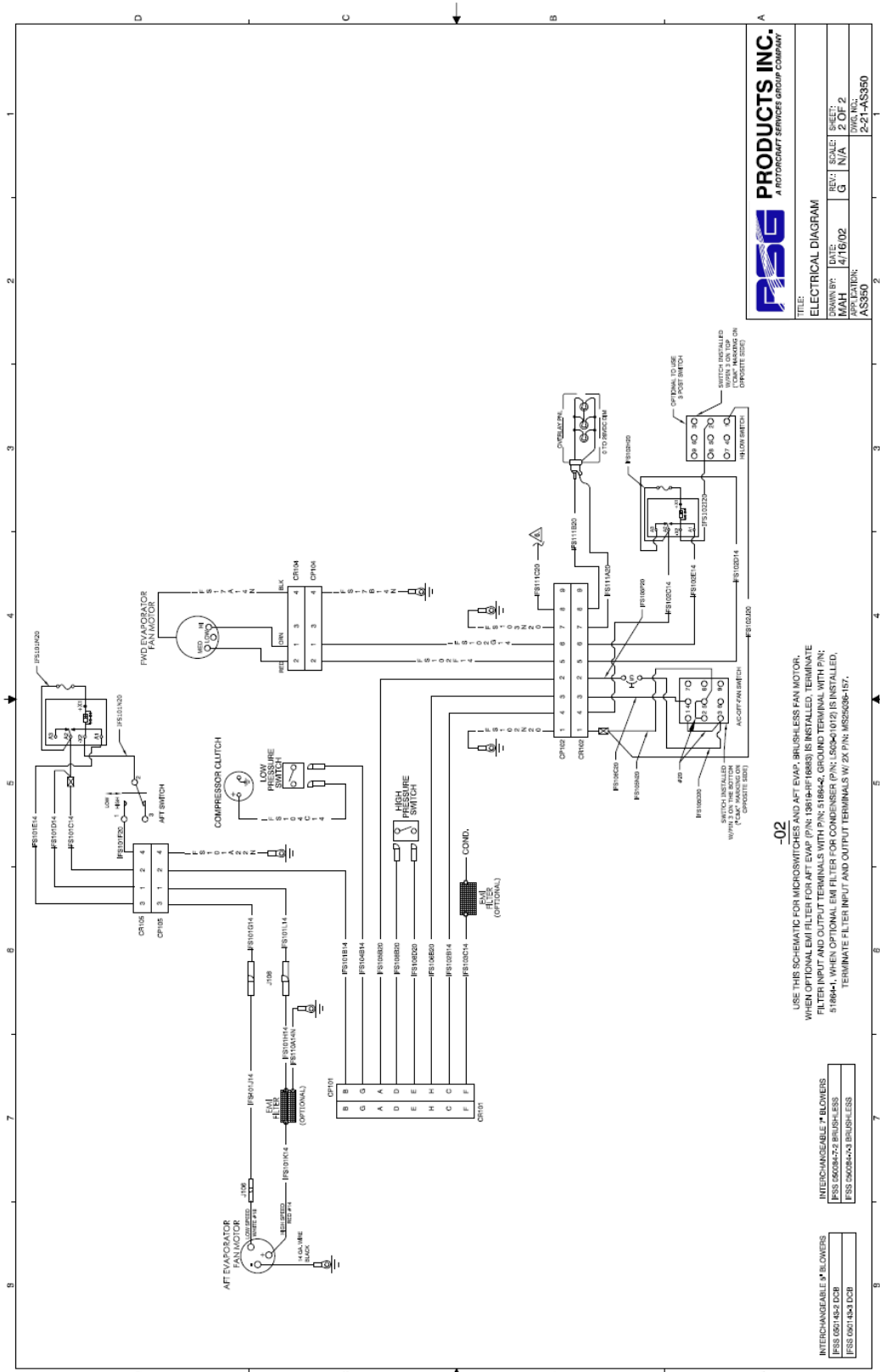

PSG PRODUCTS INC.
A ROTORCAFT SERVICES GROUP COMPANY

TITLE: ELECTRICAL DIAGRAM

DRAWN BY: MAH	DATE: 4/16/02	REV: G	SCALE: N/A	SHEET: 2 OF 2
APPROVED BY: ASB	DATE: 4/16/02	REV: G	SCALE: N/A	SHEET: 2 OF 2
PART NUMBER: 2-21-AS350				

-02

USE THIS SCHEMATIC FOR MICROSWITCHES AND AFT EVAP. BRUSHLESS FAN MOTOR. WHEN OPTIONAL EMF FILTER FOR AFT EVAP (P/N: 1816-RP-18883) IS INSTALLED, TERMINATE FILTER INPUT AND OUTPUT TERMINALS WITH P/N: 5186A-2. GROUND TERMINAL WITH P/N: 5186A-1. WHEN OPTIONAL EMF FILTER FOR CONDENSER (P/N: 15020-012) IS INSTALLED, TERMINATE FILTER INPUT AND OUTPUT TERMINALS W/ 2X P/N: MS25036-157.

INTERCHANGEABLE * BLOWERS
P/N: 1001-1502 DCB
P/N: 1001-1504 DCB

INTERCHANGEABLE * BLOWERS
P/N: 6008A-03 BRUSHLESS
P/N: 5008A-03 BRUSHLESS

TITLE: Air Conditioning System Installation Instructions For Continued Airworthiness for Airbus Helicopters AS-350 B, C, D, D1, B1, B2, B3, BA & EC-130 B4

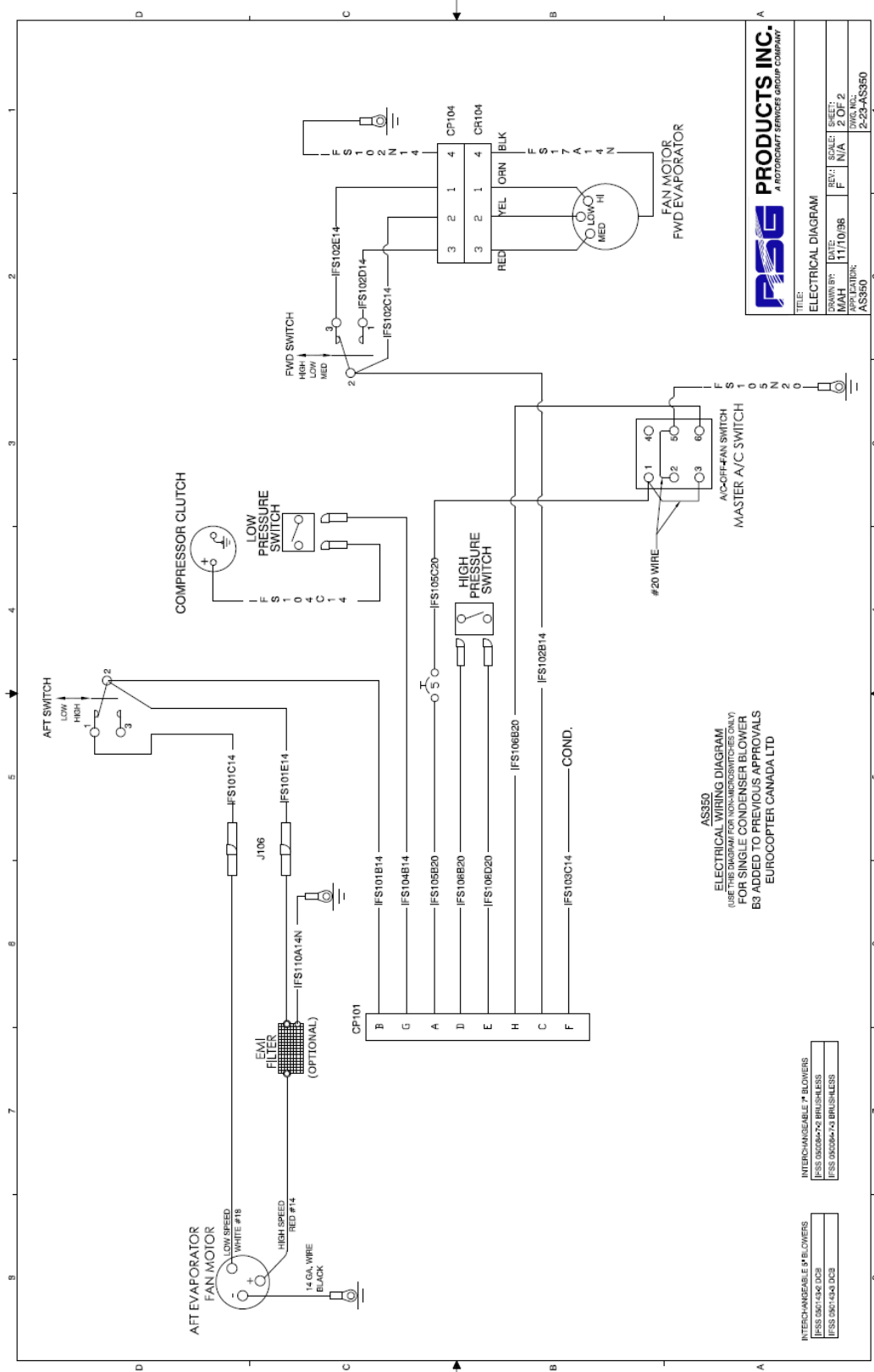

RSG PRODUCTS INC.
A ROTORCRAFT SERVICE GROUP COMPANY

TITLE: ELECTRICAL DIAGRAM
DRAWN BY: DATE: 11/10/98
MAH: REV: SCALE: N/A
REV: 2 OF 2
DATE: 2-23-ASS90

TITLE: Air Conditioning System Installation Instructions For Continued Airworthiness for Airbus Helicopters AS-350 B, C, D, D1, B1, B2, B3, BA & EC-130 B4

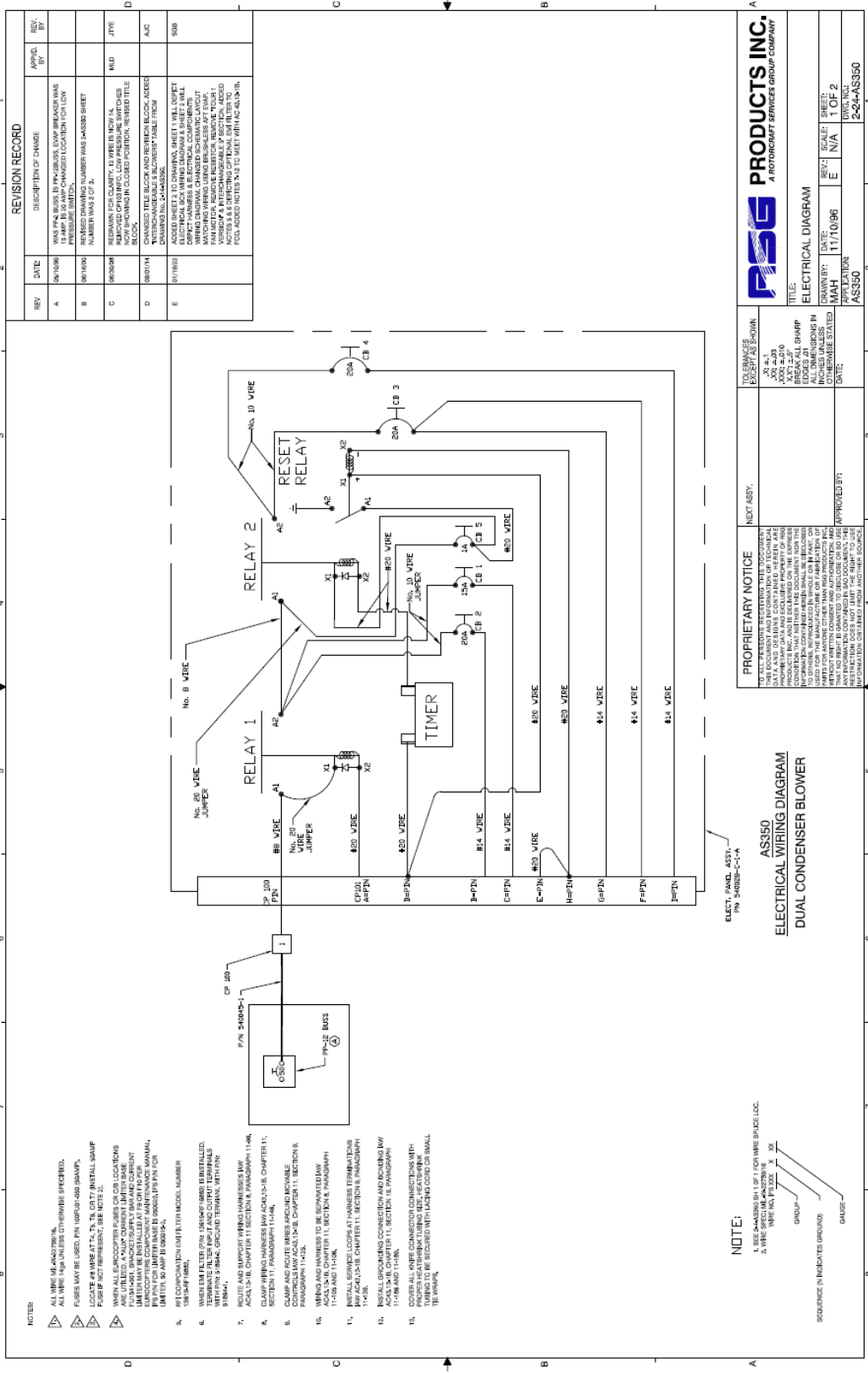

REV.	DATE	DESCRIPTION OF CHANGE	APPROV. BY	REV. ID
A	08/04/23	WAS PINK BUSH IN PAGES 85 AND 86. SWAP WIRE FROM 13 AMP TO 50 AMP CHANGED LOCATION FOR LOW PRESSURE SWITCH. NUMBER WAS 5400S SHEET NUMBER WAS 2 OF 3.		
B	08/04/23	SUGGESTION TO CLARIFY. 1 WIRE IN WIRE 14. REMOVED FROM IN CLOSED POSITION. REWIRING BLOCK.	MJD	JITE
C	08/04/23	CHANGED TITLE BLOCK AND REVISION BLOCK. ADDED REVISION NUMBER 1.		
D	08/04/23	ADDED SHEET 2 TO DRAWING. SHEET 1 WILL DISPLAY ELECTRICAL BOX WIRING DIAGRAMS SHEET 2 WILL DISPLAY WIRING DIAGRAMS. CHANGED SCHEMATIC LAYOUT WIRING DIAGRAM. REMOVED RESISTOR. REWIRING BLOCK. PAN MOUNT. REMOVED RESISTOR. REWIRING BLOCK. ADDED NOTES AS A REFERENCE TO THE ORIGINAL SHEET. TO ADD. ADDED NOTES TO MEET WIRING AS BUILT.		
E	01/18/23			508

PROPRIETARY NOTICE
 THIS DOCUMENT AND INFORMATION CONTAINED HEREIN IS THE PROPERTY OF RSG PRODUCTS INC. AND IS UNCLASSIFIED EXCEPT AS SHOWN. IT IS TO BE KEPT CONFIDENTIAL AND NOT DISCLOSED TO ANY OTHER PARTY WITHOUT THE WRITTEN CONSENT OF RSG PRODUCTS INC. ANY INFORMATION CONTAINED HEREIN IS UNCLASSIFIED EXCEPT AS SHOWN.

ASS350
 ELECTRICAL DIAGRAM
 DUAL CONDENSER BLOWER

DRAWN BY: MAH DATE: 11/10/96 REV: 1 OF 2
 APPLICATION: E N/A SCALE: 1 OF 2
 APPROVED BY: ASS350 DWG. NO.: 2-94-ASS350

NOTE:
 1. SEE PARAGRAPH 1 OF 1.000 WIRE SPEC. LOC.
 2. SEE SPEC. IMA-02728-18 WIRE TABLE FOR WIRE TYPE AND GAUGE.
 3. WIRE GAUGE.
 4. WIRE TYPE.
 5. WIRE LENGTH.
 6. WIRE COLOR.
 7. WIRE IDENTIFICATION NUMBER.
 8. WIRE IDENTIFICATION LETTER.
 9. WIRE IDENTIFICATION NUMBER.
 10. WIRE IDENTIFICATION LETTER.
 11. WIRE IDENTIFICATION NUMBER.
 12. WIRE IDENTIFICATION LETTER.
 13. WIRE IDENTIFICATION NUMBER.
 14. WIRE IDENTIFICATION LETTER.
 15. WIRE IDENTIFICATION NUMBER.
 16. WIRE IDENTIFICATION LETTER.
 17. WIRE IDENTIFICATION NUMBER.
 18. WIRE IDENTIFICATION LETTER.
 19. WIRE IDENTIFICATION NUMBER.
 20. WIRE IDENTIFICATION LETTER.

TITLE:
Air Conditioning System Installation Instructions For Continued
Airworthiness for Airbus Helicopters AS-350 B, C, D, D1, B1, B2, B3, BA &
EC-130 B4

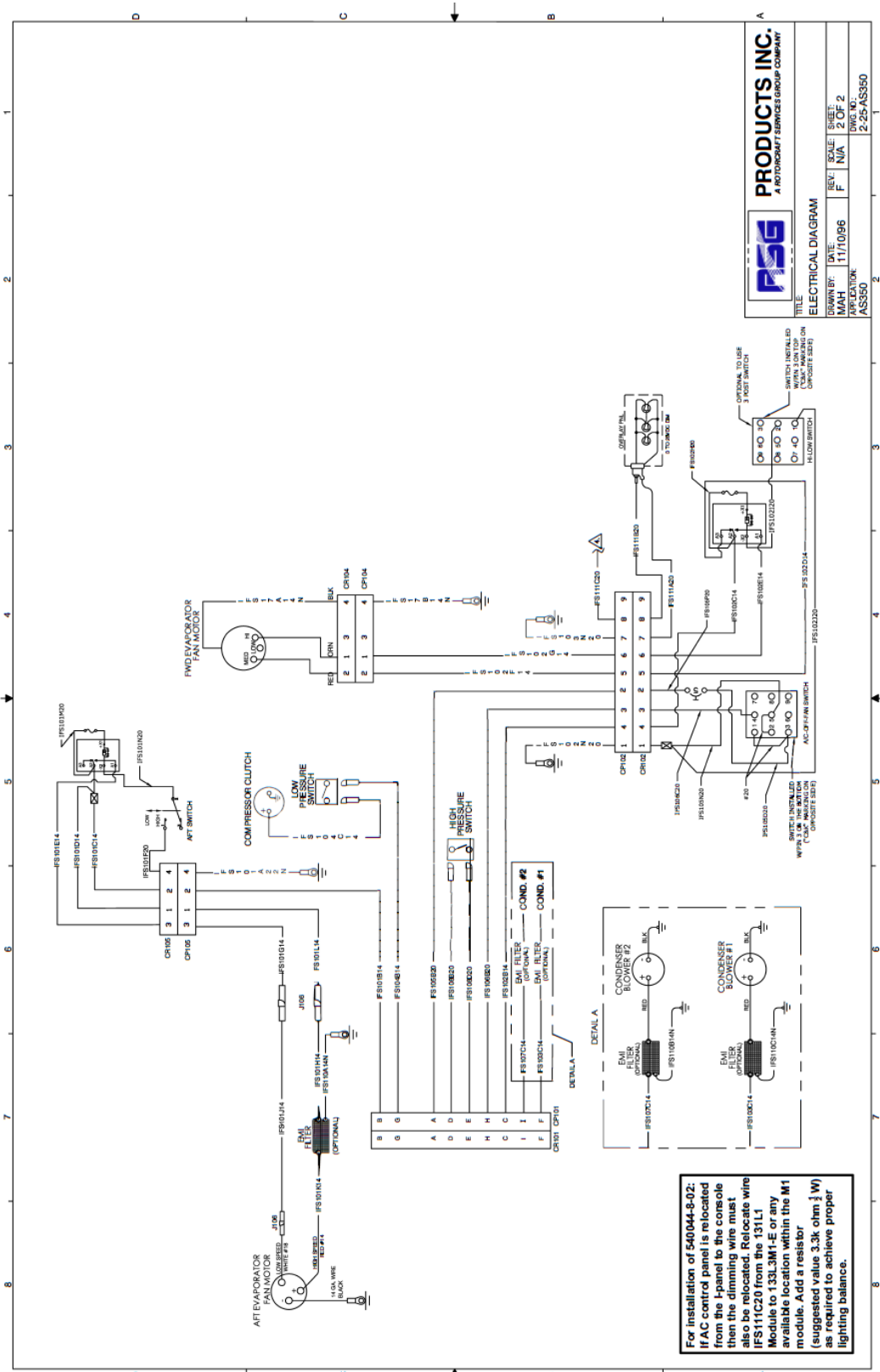

PSG PRODUCTS INC.
A ROTORCRAFT SERVICES GROUP COMPANY

TITLE: ELECTRICAL DIAGRAM

DRAWN BY: MAH	DATE: 11/10/96	REV: F	SCALE: N/A	SHEET: 2 OF 2
DESIGNED BY: AS350				2-254/AS350

For installation of 540044-B-02:
If AC control panel is relocated from the I-panel to the console then the dimming wire must also be relocated. Relocate wire IFS111C20 from the 131L1 Module to 133L3M1-E or any available location within the M1 module. Add a resistor (suggested value 3.3k ohm $\frac{1}{2}$ W) as required to achieve proper lighting balance.

TITLE: Air Conditioning System Installation Instructions For Continued Airworthiness for Airbus Helicopters AS-350 B, C, D, D1, B1, B2, B3, BA & EC-130 B4

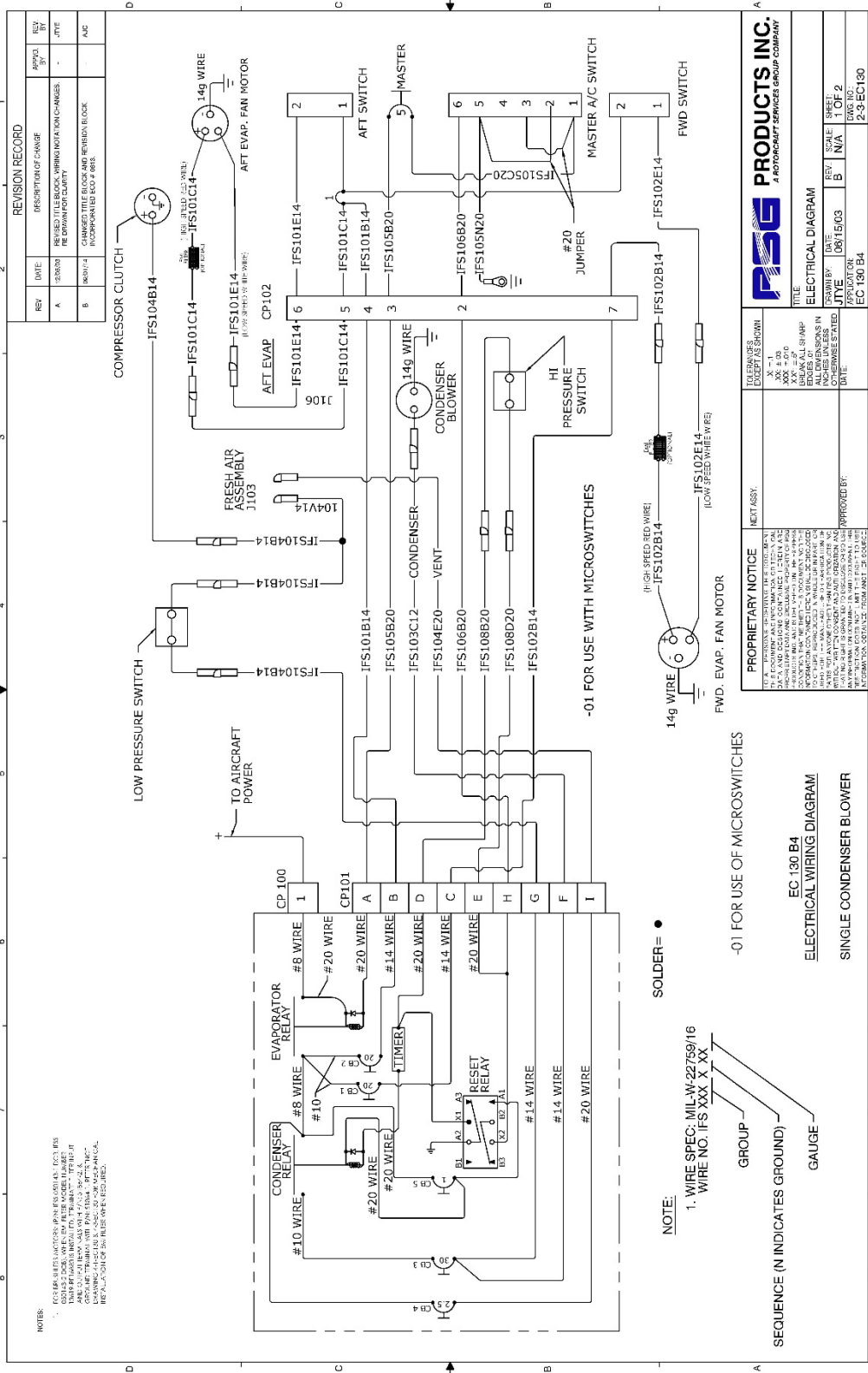

REVISION RECORD

REV	DATE	DESCRIPTION OF CHANGE	APPROVED BY	DATE
A	02/03/21	REVISED (1) (LEAKAGE) (WIRING) (NOTATION) (CHANGES) (REWORK) (FOR CLARITY)		
B	06/01/24	CHANGED TITLE BLOCK AND REVISION BLOCK (INCORPORATED ECU 2-3-1618)		

PROPRIETARY NOTICE THIS DOCUMENT IS THE PROPERTY OF RSG PRODUCTS INC. AND IS NOT TO BE REPRODUCED OR TRANSMITTED IN ANY FORM OR BY ANY MEANS, ELECTRONIC OR MECHANICAL, INCLUDING PHOTOCOPYING, RECORDING, OR BY ANY INFORMATION STORAGE AND RETRIEVAL SYSTEM, WITHOUT THE WRITTEN PERMISSION OF RSG PRODUCTS INC. THE INFORMATION CONTAINED HEREIN IS UNCLASSIFIED AND IS NOT SUBJECT TO EXPORT CONTROL.	
TELEPHONE: XXX-XXX-XXXX XXX-XXX-XXXX XXX-XXX-XXXX XXX-XXX-XXXX	EMAIL: XXX@RSG.COM XXX@RSG.COM XXX@RSG.COM XXX@RSG.COM
PERMISSIONS: ALL PERMISSIONS IN THIS DOCUMENT ARE BY THE AUTHOR. OTHERS MUST BE APPROVED BY:	
DATE: 08/15/03	REV: B
SCALE: N/A	DATE: 08/15/03
APPROVED BY: [Signature]	
ECU NO.: 2-3-EC130	

NOTES:

- FOR AIRCRAFT INSTALLATION IN AN AIRCRAFT, ELECTRICAL WIRING SHALL BE INSTALLED IN ACCORDANCE WITH THE AIRCRAFT TYPE DATA SHEET (TDS) AND THE AIRCRAFT TYPE DATA SHEET (TDS) FOR THE AIRCRAFT TYPE. THE AIRCRAFT TYPE DATA SHEET (TDS) SHALL BE USED TO DETERMINE THE AIRCRAFT TYPE DATA SHEET (TDS) FOR THE AIRCRAFT TYPE. THE AIRCRAFT TYPE DATA SHEET (TDS) SHALL BE USED TO DETERMINE THE AIRCRAFT TYPE DATA SHEET (TDS) FOR THE AIRCRAFT TYPE. THE AIRCRAFT TYPE DATA SHEET (TDS) SHALL BE USED TO DETERMINE THE AIRCRAFT TYPE DATA SHEET (TDS) FOR THE AIRCRAFT TYPE.

NOTE:
 1. WIRE SPEC: MIL-W-22759/16
 WIRE NO. IFS XXX X XX

SEQUENCE (N INDICATES GROUND)
 GROUP
 GAUGE

TITLE:
Air Conditioning System Installation Instructions For Continued Airworthiness for Airbus Helicopters AS-350 B, C, D, D1, B1, B2, B3, BA & EC-130 B4

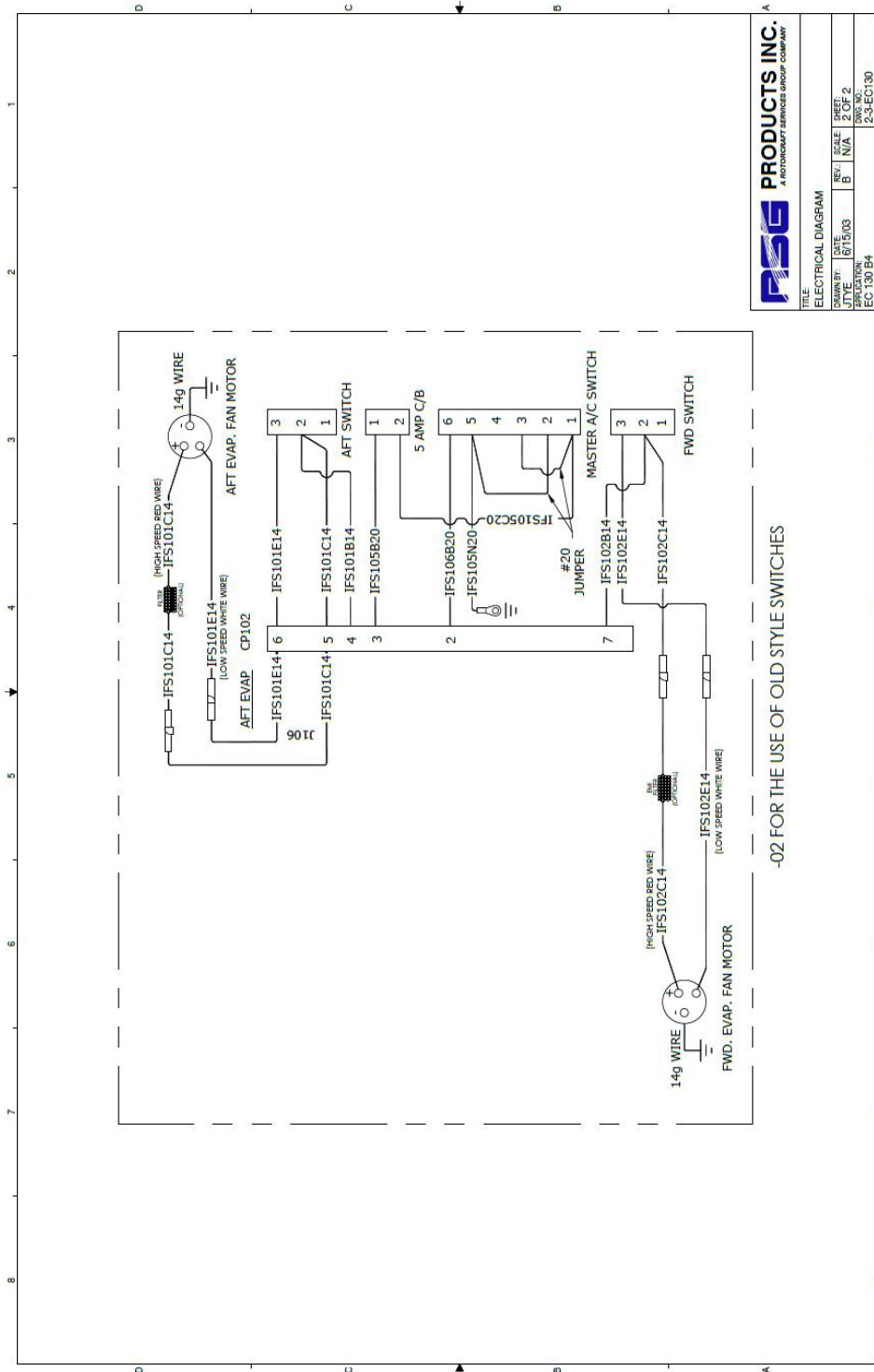

RSG PRODUCTS INC. A ROTORHUB AIRSERVICES GROUP COMPANY	
TITLE: ELECTRICAL DIAGRAM	
DESIGNED BY: BT/15/03	REV: N/A
APPROVED BY: B	REV: 2 OF 2
APPLICATION: EC-130 B4	DATE: 2-3-EC-130
	2

TITLE: Air Conditioning System Installation Instructions For Continued Airworthiness for Airbus Helicopters AS-350 B, C, D, D1, B1, B2, B3, BA & EC-130 B4

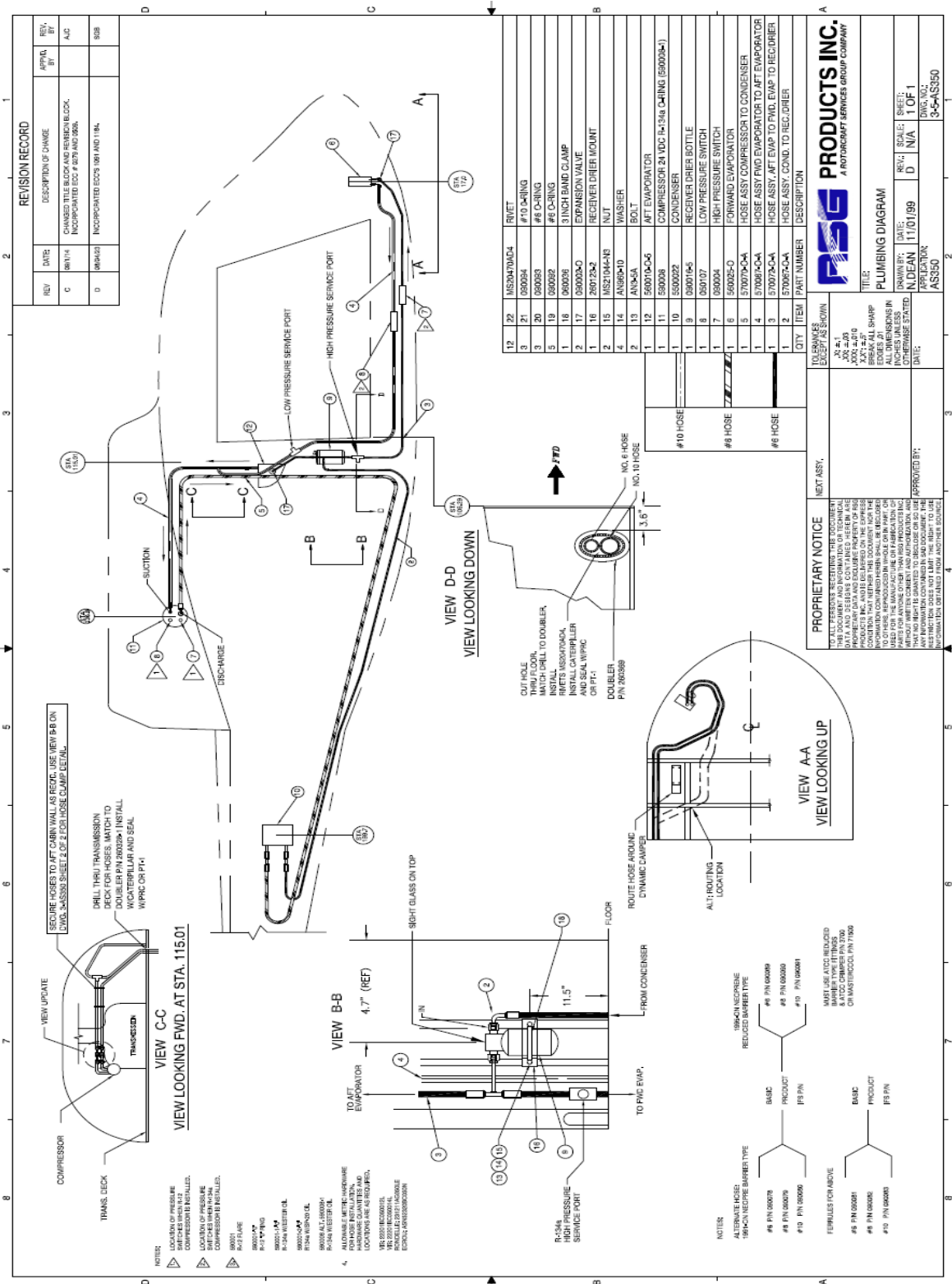

TITLE: Air Conditioning System Installation Instructions For Continued Airworthiness for Airbus Helicopters AS-350 B, C, D, D1, B1, B2, B3, BA & EC-130 B4

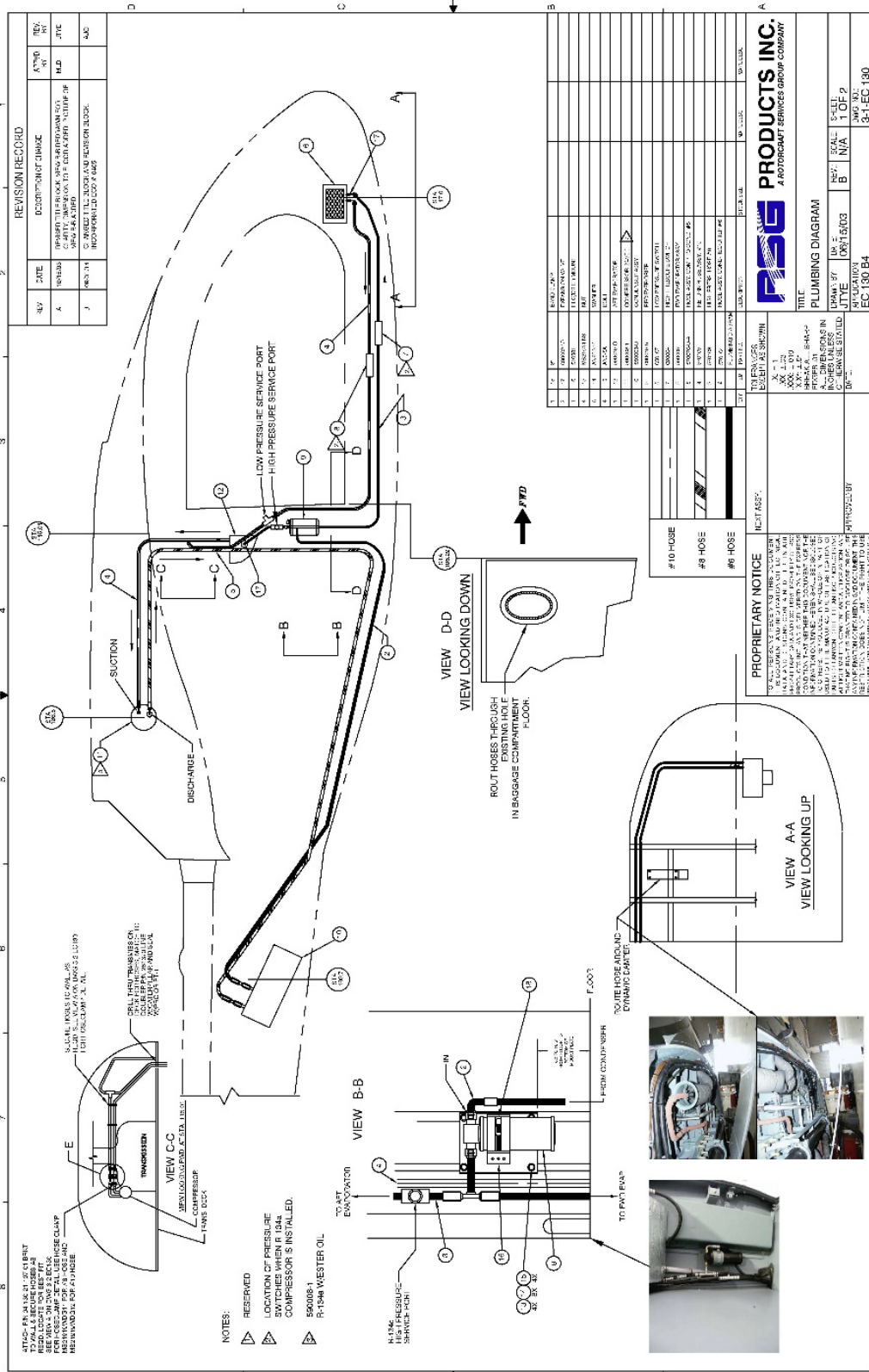



DATE:
08/04/2023

DOC No.:
IFSE-0007

REV:
F-1

PAGE:
96 of 99

TITLE:
Air Conditioning System Installation Instructions For Continued
Airworthiness for Airbus Helicopters AS-350 B, C, D, D1, B1, B2, B3, BA &
EC-130 B4

APPENDIX A Weight and Balance

PERTAINS TO KIT #350-00-011
Weight (#) X Arm (") = Moment ("#)

ITEM	WEIGHT (#)	ARM (")	MOMENT ("#)
Forward Evaporator Assembly	13.50	19.00	256.50
Forward Air Outlets	.50	31.32	15.66
Aft Evaporator and Return Air	11.50	120.00	1380.00
Aft Evaporator Blower	5.00	120.85	604.25
Condenser Coil and Mount	19.50	133.80	2609.10
Condenser Blower and Mount	14.00	148.60	2080.40
Compressor and Mount	17.00	147.80	2512.60
Electrical Relay Panes	4.0	153.70	614.80
Refrigerant, Hoses and Fittings	7.50	76.90	576.75
<hr/>			
Sub Total: (Air Conditioner)	92.5		10650.06



DATE:
08/04/2023

DOC No.:
IFSE-0007

REV:
F-1

PAGE:
97 of 99

TITLE:
Air Conditioning System Installation Instructions For Continued
Airworthiness for Airbus Helicopters AS-350 B, C, D, D1, B1, B2, B3, BA &
EC-130 B4

PERTAINS TO KIT #350-00-031
Weight (#) X Arm (") = Moment ("#)

ITEM	WEIGHT (#)	ARM (")	MOMENT ("#)
Forward Evaporator Assembly	13.50	19.00	256.50
Forward Air Outlets	.50	31.32	15.66
Aft Evaporator and Return Air	11.50	120.00	1380.00
Aft Evaporator Blower	5.00	120.85	604.25
Condenser Assy. & Mount w/ Dual condenser blowers and closeout panel	40.00	201.80	8072.00
Compressor and Mount	17.00	147.80	2512.60
Electrical Relay Panes	4.0	153.70	614.80
Refrigerant, Hoses and Fittings	7.50	76.90	576.75
Sub Total: (Air Conditioner)	99.00		14032.56



DATE: 08/04/2023	DOC No.: IFSE-0007	REV: F-1	PAGE: 98 of 99
---------------------	-----------------------	-------------	-------------------

TITLE:
Air Conditioning System Installation Instructions For Continued
Airworthiness for Airbus Helicopters AS-350 B, C, D, D1, B1, B2, B3, BA &
EC-130 B4

PERTAINS TO KIT # 130-00-031
Weight (#) X Arm (") = Moment ("#)

ITEM	WEIGHT (#)	ARM (")	MOMENT ("#)
FWD. EVAP ASSY W/ MOTOR	14.0	24.0	336
FWD AIR OUTLETS (x2) W/ DUCTING	3.0	33.29	99.87
AFT EVAP W/ MOTOR & DUCTS	16.0	120.5	1928
CONDENSER ASSY W/ MOTOR & AIR DISCHARGE	33.0	223.3	7368.9
COMPRESSOR W/ MOUNTING KIT	17.5	147.8	2586.5
ELECTRICAL CONTROL BOX	4.0	153.7	614.8
REFRIGERANT HOSES	5.0	76.9	384.5
ELECTRICAL HARNESS	3.5	70.0	245
INSTALLATION TOTALS	96.0		13563.57

Step 13

Parts Break Down

RSG Products Inc.
PARTS BREAK DOWN – B4 Air Conditioning

Parts break down consist of components and locations on sheet 2-1-EC130.

Hose and Routing on Sheet 3-1-EC130 and 3-2-EC130.

NOTES:

USE EXISTING LIGHTENING HOLES ONLY FOR ALL ROUTING OR SECURE WIRES TO EXISTING BUNDLES OR REFRIGERATION HOSE USING TY-WRAPS, STAND-OFFS, AND SPACERS BLOCKS AS REQUIRED.

- ▶ LOCATION OF PRESSURE SWITCHES WHEN R-134a IS UTILIZED.
- ▶ ON B3 MODELS IFS WIRE ROUTING MUST BE ACCORDANCE WITH THIS DRAWING.
- ▶ INSTALL IFS104C14 TO LOW PRESSURE SWITCH. (BLUE LEADS)
- ▶ INSTALL IFS108B20 AND IFS108D20 TO HIGH PRESSURE SWITCH. (BLACK LEADS)

REVISION RECORD				
REV	DATE	DESCRIPTION OF CHANGE	APPVD. BY	REV. BY
A	08/14/09	REVISED TITLE BLOCK. EVAPORATOR BLOWER PART NO. WAS 490017 OR 490017-1, IS NOW 050143. ADDED ALTERNATE LOCATION FOR ELECTRICAL BOX. REVISED ELECTRICAL ROUTING. CHANGED RESISTOR ASSEMBLY PN TO 540020, ADDED ANL-50 LIMITER. ADDED LISTINGS OF INTERCHANGEABLE BLOWER ASSEMBLIES.		JTYE
B	09/01/14	CHANGED TITLE BLOCK AND REVISION BLOCK. INCORPORATED ECO # 0357.		AJC
C	08/04/23	REMOVED RESISTOR ASSEMBLY. INCORPORATED ECO 1027.		SGB

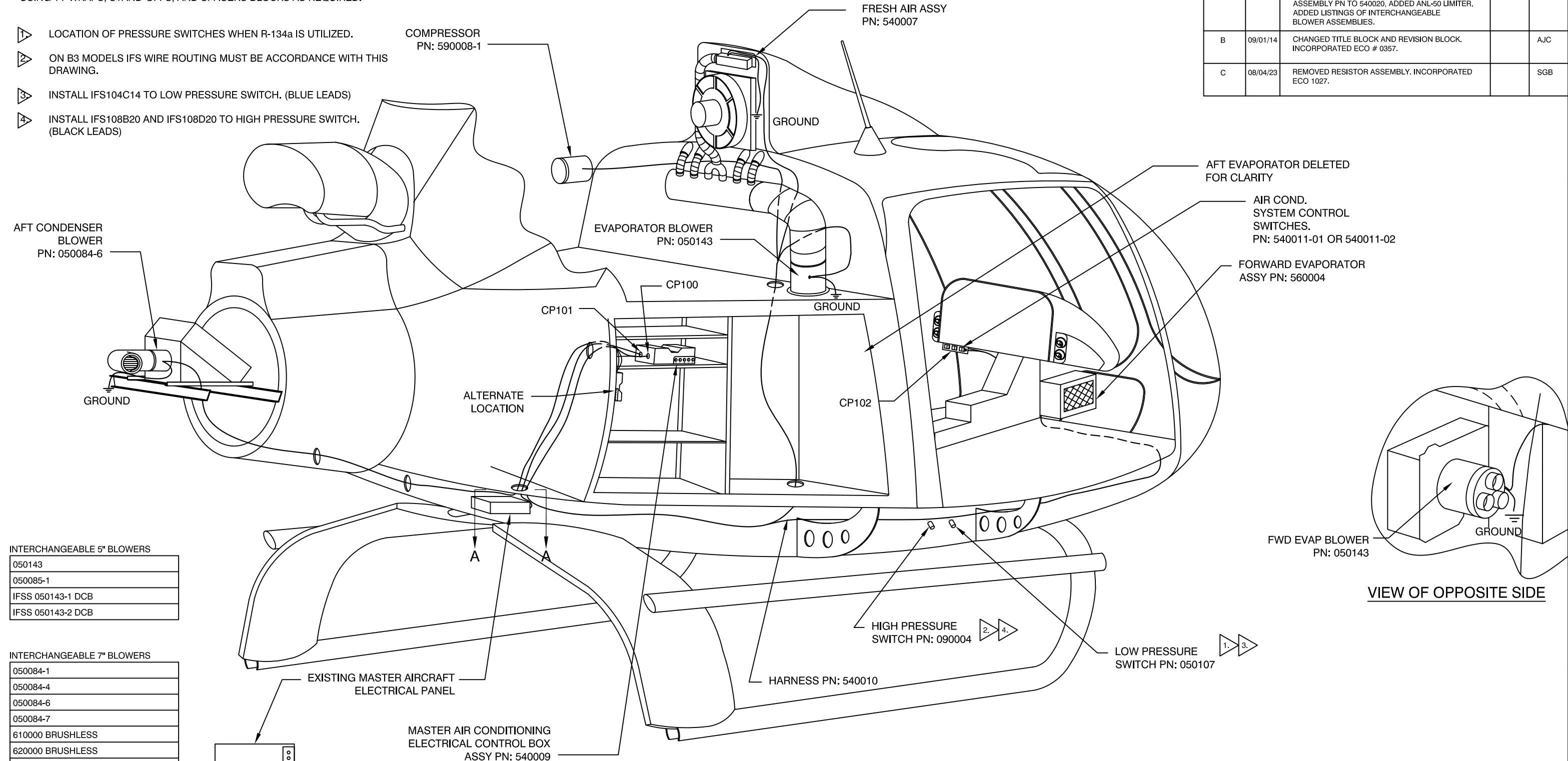

INTERCHANGEABLE 5" BLOWERS

050143
050085-1
IFSS 050143-1 DCB
IFSS 050143-2 DCB

INTERCHANGEABLE 7" BLOWERS

050084-1
050084-4
050084-6
050084-7
610000 BRUSHLESS
620000 BRUSHLESS
630000
640000
IFSS 050084-1
IFSS 050084-4
IFSS 050084-6
IFSS 050084-6-1
IFSS 050084-7 BRUSHLESS
IFSS 050084-7-1 BRUSHLESS

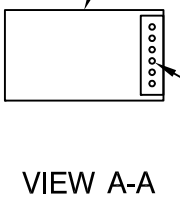
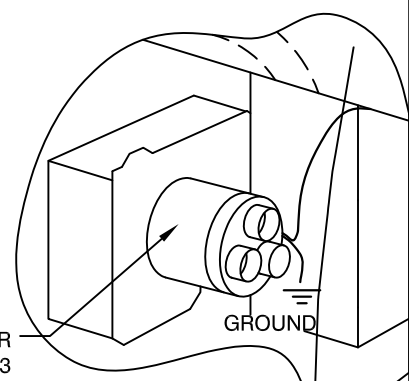

USE ANL-50 LIMITER, OR 50 AMP CIRCUIT BREAKER, OR FUSE AT PP-12 BUSS

<p>PROPRIETARY NOTICE</p> <p>TO ALL PERSONS RECEIVING THIS DOCUMENT THIS DOCUMENT AND INFORMATION OR TECHNICAL DATA AND DESIGNS CONTAINED HEREIN ARE PROPRIETARY DATA AND EXCLUSIVE PROPERTY OF RSG PRODUCTS INC. AND IS DELIVERED ON THE EXPRESS CONDITION THAT NEITHER THIS DOCUMENT NOR THE INFORMATION CONTAINED HEREIN SHALL BE DISCLOSED TO OTHERS, REPRODUCED IN WHOLE OR IN PART, OR USED FOR THE MANUFACTURE OR FABRICATION OF PARTS FOR ANYONE OTHER THAN RSG PRODUCTS INC. WITHOUT WRITTEN CONSENT AND AUTHORIZATION, AND THAT NO RIGHT IS GRANTED TO DISCLOSE OR SO USE ANY INFORMATION CONTAINED IN SAID DOCUMENT. THIS RESTRICTION DOES NOT LIMIT THE RIGHT TO USE INFORMATION OBTAINED FROM ANOTHER SOURCE.</p>	<p>NEXT ASSY.</p>	<p>TOLERANCES EXCEPT AS SHOWN</p> <p>.X: ±.1 .XX: ±.03 .XXX: ±.010 X.X": ±.5" BREAK ALL SHARP EDGES .01 ALL DIMENSIONS IN INCHES UNLESS OTHERWISE STATED</p>
	<p>APPROVED BY:</p>	<p>DATE:</p>

RSG PRODUCTS INC.
A ROTORCRAFT SERVICES GROUP COMPANY

TITLE:
ELECTRICAL ROUTING

DRAWN BY: JTYE	DATE: 06/15/03	REV.: C	SCALE: N/A	SHEET: 1 OF 1
APPLICATION: EC 130 B4			DWG. NO.: 2-1-EC130	

ATTACH P/N 04-130-21-107-01 BRKT TO WALL & SECURE HOSES AS REQD. LOCATE FOR BEST FIT. SEE VIEW A ON DWG 3-2 EC130 FOR HOSECLAMP DETAIL. USE HOSE CLAMP MS21919WDG11 FOR #8 HOSE AND MS21919WDG12 FOR #10 HOSE.

SECURE HOSES TO WALL AS REQD. SEE VIEW A ON DWG 3-2 EC130 FOR HOSECLAMP DETAIL.

DRILL THRU TRANSMISSION DECK FOR HOSES, MATCH TO DOUBLER P/N 261370 LINE W/CATERPILLAR AND SEAL W/PRC OR PT-1

VIEW C-C
VIEW LOOKING FWD. AT STA. 115.01

COMPRESSOR
TRANS. DECK

NOTES:

- 1 RESERVED
- 2 LOCATION OF PRESSURE SWITCHES WHEN R-134a COMPRESSOR IS INSTALLED.
- 3 590008-1 R-134a W/ESTER OIL

VIEW B-B

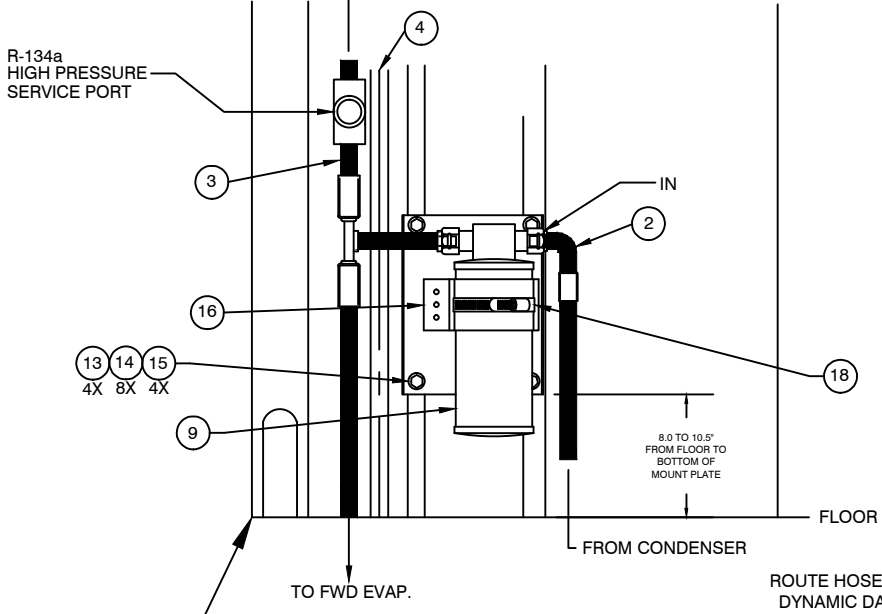

VIEW D-D
VIEW LOOKING DOWN

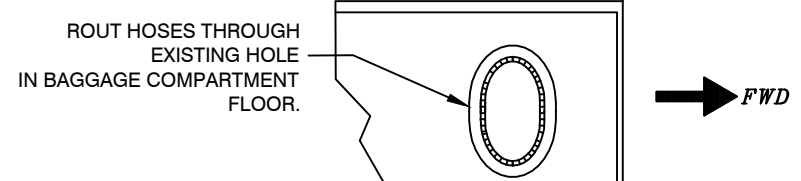

ROUTE HOSE AROUND DYNAMIC DAMPER

VIEW A-A
VIEW LOOKING UP

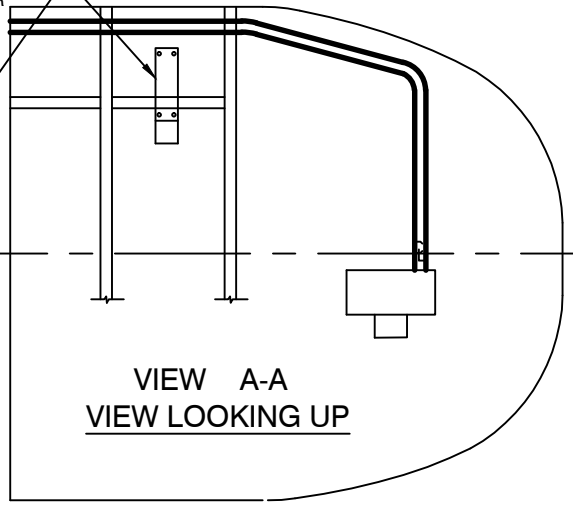

REVISION RECORD				
REV	DATE	DESCRIPTION OF CHANGE	APPVD. BY	REV. BY
A	10/15/03	REVISED TITLE BLOCK. VIEW B-B REDRAWN FOR CLARITY, DIMENSION TO FLOOR ADDED. PICTURE OF VIEW B-B ADDED.	MLD	JTYE
B	09/01/14	CHANGED TITLE BLOCK AND REVISION BLOCK. INCORPORATED ECO # 0405		AJC

QTY.	ITEM	PART NO.	DESCRIPTION	STOC.	SU E	MATL DESC.	MATL DESC.
1	18	3"	BAND CLAMP				
2	17	090002-0"	EXPANSION VALVE				
1	16	510381	REC/DRIER MOUNT				
4	15	MS21044-N3	NUT				
8	14	AN960-10	WASHER				
4	13	AN3-5A	BOLT				
1	12	560016-0	AFT EVAPORATOR				
1	11	590008-1	COMPRESSOR 24VDC				
1	10	550003-0	CONDENSER ASSY				
1	9	090016-5	RECIEVER/DRIER				
1	8	050107	LOW PRESSURE SWITCH				
1	7	090004	HIGH PRESSURE SWITCH				
1	6	560006	FWD EVAPORATOR ASSY.				
1	5	570070-O-A	HOSE ASSY, COMP TO COND. #8				
1	4	570105	RETURN HOSE ASSY. #10				
1	3	570103	HIGH PRESS. HOSE #6				
1	2	570104	HOSE ASSY, COND-REC/DRIER #6				
			PLUMBING DIAGRAM				

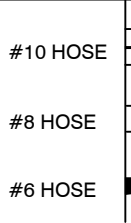

PROPRIETARY NOTICE

TO ALL PERSONS RECEIVING THIS DOCUMENT THIS DOCUMENT AND INFORMATION OR TECHNICAL DATA AND DESIGNS CONTAINED HEREIN ARE PROPRIETARY DATA AND EXCLUSIVE PROPERTY OF RSG PRODUCTS INC. AND IS DELIVERED ON THE EXPRESS CONDITION THAT NEITHER THIS DOCUMENT NOR THE INFORMATION CONTAINED HEREIN SHALL BE DISCLOSED TO OTHERS, REPRODUCED IN WHOLE OR IN PART, OR USED FOR THE MANUFACTURE OR FABRICATION OF PARTS FOR ANYONE OTHER THAN RSG PRODUCTS INC. WITHOUT WRITTEN CONSENT AND AUTHORIZATION, AND THAT NO RIGHT IS GRANTED TO DISCLOSE OR SO USE ANY INFORMATION CONTAINED IN SAD DOCUMENT. THIS RESTRICTION DOES NOT LIMIT THE RIGHT TO USE INFORMATION OBTAINED FROM ANOTHER SOURCE.

NEXT ASSY.
APPROVED BY:
TOLERANCES EXCEPT AS SHOWN
.X: ±.1
.XX: ±.03
.XXX: ±.010
X.X": ±.5°
BREAK ALL SHARP EDGES .01
ALL DIMENSIONS IN INCHES UNLESS OTHERWISE STATED
DATE:



TITLE:
PLUMBING DIAGRAM
DRAWN BY: JTYE
DATE: 06/15/03
REV.: B
SCALE: N/A
SHEET: 1 OF 2
APPLICATION: EC 130 B4
DWG. NO.: 3-1-EC 130



REVISION RECORD				
REV	DATE	DESCRIPTION OF CHANGE	APPVD. BY	REV. BY
A	03/31/09	REVISED TITLE BLOCK.		DWE
B	9/1/14	CHANGED TITLE BLOCK AND REVISION BLOCK.		AJC

EXTREMELY IMPORTANT
FAILURE TO SECURE EXPANSION VALVE SENSING BULB, TIGHTLY, TO THE RETURN LINE HOSE FITTING (#10) WITH A STAINLESS STEEL CLAMP (AND INSULATE SENSING BULB & LINE) WILL DRAMATICALLY DECREASE THE PERFORMANCE OF THE AFT EVAPORATOR (NOT FORWARD).

SECURE HOSES TO FIREWALL
SEE DWG 3-1-EC130 (SH 1 OF 1)
VIEW C-C

CONDENSER

COMPRESSOR



AFT EVAPORATOR
EXPANSION VALVE

FWD EVAPORATOR

SEE DWG 3-1-EC130
(SH 1 OF 1),
VIEW D-D

LOW PRESSURE SWITCH
P/N 050107



VIEW A

HIGH PRESSURE SWITCH
P/N 090004

AN3-4A BOLT OR
AN525-10R10 SCREW
AN960-10 WASHER
MS21044-N3 NUT

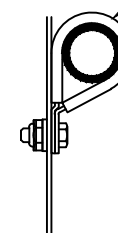

VIEW A

TYPICAL HOSE INSTALLATION:

FOR #6 HOSE ATTACH WITH TIE WRAP

FOR #8 HOSE ATTACH WITH TIE WRAP

FOR #10 HOSE ATTACH WITH ADEL CLAMP, TIE WRAP AND MS21919DG12 & HARDWARE AS SHOWN

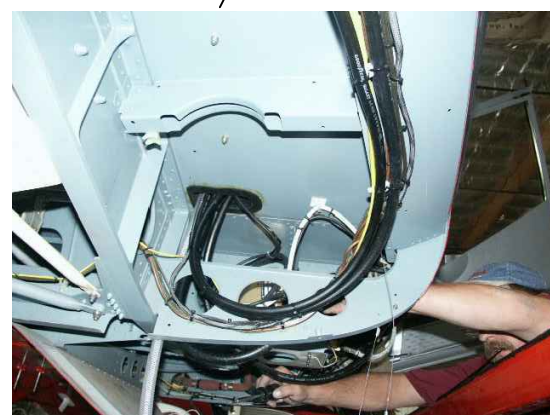

PROPRIETARY NOTICE

TO ALL PERSONS RECEIVING THIS DOCUMENT THIS DOCUMENT AND INFORMATION OR TECHNICAL DATA AND DESIGNS CONTAINED HEREIN ARE PROPRIETARY DATA AND EXCLUSIVE PROPERTY OF RSG PRODUCTS INC. AND IS DELIVERED ON THE EXPRESS CONDITION THAT NEITHER THIS DOCUMENT NOR THE INFORMATION CONTAINED HEREIN SHALL BE DISCLOSED TO OTHERS, REPRODUCED IN WHOLE OR IN PART, OR USED FOR THE MANUFACTURE OR FABRICATION OF PARTS FOR ANYONE OTHER THAN RSG PRODUCTS INC. WITHOUT WRITTEN CONSENT AND AUTHORIZATION, AND THAT NO RIGHT IS GRANTED TO DISCLOSE OR SO USE ANY INFORMATION CONTAINED IN SAD DOCUMENT. THIS RESTRICTION DOES NOT LIMIT THE RIGHT TO USE INFORMATION OBTAINED FROM ANOTHER SOURCE.

NEXT ASSY.

TOLERANCES EXCEPT AS SHOWN

.X: ±.1
.XX: ±.03
.XXX: ±.010
X.X°: ±.5°
BREAK ALL SHARP EDGES .01
ALL DIMENSIONS IN INCHES UNLESS OTHERWISE STATED
DATE:

APPROVED BY:



RSG PRODUCTS INC.
A ROTORCRAFT SERVICES GROUP COMPANY

TITLE:
PLUMBING ROUTING

DRAWN BY: JTYE DATE: 06/15/03 REV.: B SCALE: N/A SHEET: 1 OF 1

APPLICATION: EC 130 B4 DWG. NO.: 3-2-EC130

Step 14

T&C/Warranty/RMA



Standard Terms and Conditions of Sale

1. Terms of Payment: Unless prior arrangements are made to establish credit terms RSG Products Inc., all sales are prepaid in full prior to shipment. Payment may be made via cash, check or electronic transfer to RSG Products Inc. prior to delivery.

2. Buyer's Deposit: A 50% deposit is required to process an order for an air conditioning kit. The deposit is non-refundable and will be applied to the final price of the kit.

3. Taxes / Other Charges: Prices of the specified products are exclusive of all city, state, federal and international taxes, duties, levies or charges of any kind, including, without limitation, taxes on manufacture, sales, receipts, gross income, occupation, use and similar taxes or other charges. Whenever applicable, any taxes or other charges shall be added to the invoice as a separate charge to be paid by Buyer.

4. Shipment and Packaging: All products will be suitably packed, marked and shipped F.O.B. RSG Products Inc. Fort Worth Texas, in accordance with standard packaging procedures.

5. Delays: RSG Products Inc. will not be liable for any delay in the performance of orders or contracts, or in the delivery or shipment of goods, or for any damages suffered by Buyer by reason of such delays.

6. Technical Advice: RSG Products Inc. technical support staff is available for telephone consultation concerning the products it manufactures; however, RSG Products does not warrant or guarantee such advice.

7. Aircraft Variation: Due to aircraft manufacturing variations, alterations and other factors, there are differences between aircraft of a certain make and model. Because of these variations, RSG Products Inc. does not guarantee that Buyer has purchased the correct product or that a specified product will fit the intended aircraft. Further, RSG Products does not guarantee the number of labor hours required to install its products.

8. Returns: All sales are final unless a return is approved at the sole discretion of RSG Products Inc. If RSG Products Inc. does agree to accept a return, **25% restocking fee will be charged for all parts returned.** If RSG Products Inc. does agree to accept a return, **50% restocking fee will be charged for all AC Kits returned. All items returned to RSG Products Inc. must be sent freight prepaid and must have a return material authorization (RMA) number clearly marked on the shipping container.**

9. No Fault Found: If items are sent to RSG Products Inc. for evaluation and no problem is found, or if Buyer elects not to make the required repairs, then Buyer shall be responsible for the payment of **\$300 evaluation fee.**

10. Certificate of Conformity: RSG Products Inc. will provide a Certificate of Conformity with each product assuring that the product has been manufactured according to its approved design drawings. Any additional assurances or certifications shall be at the expense of Buyer and shall be added to the invoice as a separate charge to be paid by Buyer.

11. Failed Products: Should any product prove defective, RSG Products Inc. will either replace the item or adjust the matter fairly and promptly, but under no circumstances shall RSG Products be liable for consequential or other damages, losses, or expenses in connections with or by reason of the use or liability to use products purchased for any purpose.

12. Patents: Buyer shall hold RSG Products Inc. harmless from, and release and not make claim or suit against RSG Products because of any suits, claims, losses, or other liability made against, or suffered by, Buyer arising from any claim of, or infringement of, patent, copyright, trademark, or other proprietary right, at common law, or claim of unfair trade or of unfair competition, resulting from, or occasioned by Buyer's use, possession, sale, or delivery of the products sold to Buyer by RSG Products Inc.

13. Warranty Registration and Claims: The terms RSG Products Inc. Limited Warranty is written on the Warranty Registration Card and published on the Rotorcraft Service Group, website www.rotorcraftservices.com. The registration form must be completed and returned to RSG Products Inc. within 1 month of receipt of a product. Failure to complete the Warranty Registration Card may result in denial of a claim. In order to process a warranty claim, complete the Warranty Claim Form found under Customer Support on our website and e-mail to info@rotorcraftservices.com or fax to +1 817 624 6603, or call RSG Products Inc. at +1 817-624 6600. A Warranty Claim without a Return Material Authorization (RMA) Number will cause delays and a possible denial of the claim.



WEBSITE

Terms of Use. When you access, browse or use this Site, you accept, without limitation or qualification, the terms and conditions set forth below. If you do not agree to them, do not use the Site or download any materials from integratedflightsys.com. The information herein contained may include technical inaccuracies or typographical errors. Changes may periodically be made to the information and will be incorporated in new editions of this document without notice. In no event will RSG Products Inc. be liable to any party for any direct, indirect, special or other consequential damages for any use of this web site or any other hyper linked site; including without limitation any lost profits, business interruption, loss of programs or other data on your information handling system.

Site Information. Site information regarding RSG Products Inc., services, technical parts and components, including their availability, appearance, price and specifications are subject to change without notice. In no event shall RSG Products be held liable for indirect or consequential damages or any damages resulting from the use of information from this Site. The information on this Site is at the recipient's own risk.

Links. This site contains links to other Sites on the World Wide Web. RSG Products Inc. provides such links for your convenience only, and is not responsible for the content of any Site linked to or from this Site. Links from this Site to any other Site does not mean that RSG Products Inc. approves of, endorses or recommends that Site.

Rights of Use. Any person is hereby authorized to view, copy, print, and distribute any document published by Integrated Flight Systems Corp/RSG Products Inc. provided that it is: for personal use, for information purposes and reference must be made to RSG Products Inc. when the document is used.

Information Collected. When you visit this site, RSG Products Inc. may collect information in two ways – through information automatically gathered from your computer or through information you voluntarily provide. As to automatically gathered information, RSG Products collects navigational information about where visitors go on our Site, how many visits are made to the Site, when the Site is visited and other non-personally identifiable information (for example, this can include domain type, browser version, service provider, IP address). The navigational information that is automatically gathered when you visit rotorcraftservices.com is used on an aggregate basis to evaluate and effectiveness of our Site, to analyze trends and to administer the Site. This navigational information allows us to determine such things as which areas are most visited and difficulties our visitors may experience in accessing our Site. Voluntarily provided information is collected online if you elect to e-mail RSG Products Inc. Whenever this act is made the information you voluntarily provide, name, e-mail address, phone number, specific information comments or questions, is not distributed and is confidential. All information collected from our site and/or information voluntarily provided is kept confidential and is not distributed for any reason without your approval.

14. Acceptance: This is not a firm offer and may be changed or revoked at any time. Acceptance of this offer is expressly limited to the exact terms contained herein, or as may be changed by a prior written contract between the Buyer and RSG Products Inc., and any attempt to alter or omit any of such terms shall be deemed a rejection and a counteroffer.



Warranty Policy

RSG Products Inc., warrants that each of its Air Conditioning Systems (the "Equipment") shall be free from defects in material and workmanship under normal use and service until one year after its date of sale if, and only if, installation, maintenance and operation of the Equipment is in accordance with the specifications and instructions provided by RSG Products Inc. and no substitute parts are installed in accordance with the specifications and instructions provided by RSG Products Inc. and no substitute parts are installed in the equipment without the prior written authorization from RSG Products Inc.. For the complete kit and its components, the warranty period is 12 months or 1,000 hours, whichever comes first, from the date of sale. If the Warranty Registration Form is completed and **returned within 1 month** of receipt of product, warranty terms will be extended from 12 months to 18 months. In the case of new spare parts, this warranty is limited to a period of 6 months from the date of sale. In the case of rebuilt products, this warranty is limited to a period of 3 months from the date of sale. Any claims under this warranty shall be made to RSG Products Inc., 440 West Lane, Suite 100, Saginaw, Texas 76131, USA. Warranty is not valid unless the [Warranty Registration Form](#) is completed and returned to RSG Products Inc. prior to any claim. The [RMA Claim Form](#) must be completed to receive an RMA Number and the required documentation to be returned with the Equipment. A Warranty Claim without a Return Material Authorization (RMA) Number or a completed Warranty Registration Form will cause delays and a possible denial of the claim. All claims shall be handled according to standard warranty repair procedures.

Limitations & Exclusions. This warranty shall not apply to any Equipment repaired or altered outside the Rotorcraft Services Inc. Service Department unless express prior written authorization is granted: nor shall this warranty apply to any Equipment that has been subjected to misuse or accident, as determined solely by Rotorcraft Services Inc. The sole responsibility and liability of RSG Products Inc. and your exclusive remedy under any claim arising out of, connected with, or resulting from this sale or the performance or breach or any condition of warranty there under, or from the manufacture, delivery, or use of the Equipment shall be the repair or replacement of defective equipment upon return of the defective equipment to RSG Products Inc. with transportation, customs and any applicable import duties prepaid and provided that an inspection by RSG Products Inc. discloses that the equipment is defective and covered by this warranty. RSG Products Inc. shall not be liable for any labor or other charges necessary to remove or reinstall the Equipment. In no event, whether as a result of a breach of contract, warranty, tort (including negligence) or otherwise, shall RSG Products Inc. be liable for any special, consequential, incidental or penal damages or expenses including but not limited to loss of profit, goodwill or revenues, loss of use of the Equipment or any associated equipment, damage to associated equipment, cost of capital, cost of substitute products, facilities or services, down time, or costs or claims of third parties for such damages or expenses.

THE FOREGOING WARRANTY IS EXCLUSIVE AND IN LIEU OF ALL OTHER WARRANTIES OR REMEDIES WHETHER WRITTEN, ORAL, IMPLIED OR STATUTORY, ANY AND ALL IMPLIED WARRANTIES OF MERCHANTABILITY, FITNESS FOR A PARTICULAR PURPOSE, COURSE OF DEALING OR USAGE OF TRADE ARE HEREBY EXPRESSLY DISCLAIMED AND EXCLUDED. Acceptance of the Equipment by you shall constitute your acknowledgement and acceptance of the terms, provisions, limitations and exclusions set forth herein. Such term, provisions, limitations and exclusions shall not be modified, deleted or supplemented. In a case where the purchaser has negotiated warranty terms by express written agreement with RSG Products Inc. as to certain equipment, the terms of that agreement shall supersede the warranty.

Extended Warranty. The extended warranty that is available for a fee at time of original purchase of the new product applies an 18 month period to the foregoing warranty.



WARRANTY REGISTRATION FORM

DATE: _____

CUSTOMER NAME: _____

ADDRESS: _____

CITY: _____ STATE: _____ ZIP: _____

PHONE NUMBER: (____) _____ FAX NUMBER:(____) _____

COMPONENT NAME: _____

PART NUMBER: _____ SERIAL NUMBER: _____

TYPE AIRCRAFT: _____ N#: _____ S/N: _____

AIR CONDITIONING INSTALLATION DATE: _____

AIR CONDITIONING INSTALLATION COMPANY: _____

DATE INSTALLED: _____ T.T AT INSTALLATION: _____

COPY OF T.T. LOG BOOK ENTRY OF A/C INSTALL SIGN OFF.

This Form Must be received from the Owner of the Aircraft for the warranty to be active.

Warranty period extends from Date of Purchase for a period of one year or 1000 hours

Subject to the limitations identified in the attached Warranty Policy; effective 1 July 2013. If warranty registration form is completed and returned within 1 month of receipt of product, warranty terms will be extended from 1 year to 1 year and 6 months.

**PLEASE REVIEW RSG PRODUCTS, INC. WARRANTY POLICY
PRIOR TO SUBMITTING THIS REGISTRATION FORM.**

Return Material Authorization (RMA) Form

	RMA Number:	
	Date Issued:	
	Issued by:	

<p>RMA Instructions: Products purchased through RSG may be returned by following these steps:</p> <p>1. Contact RSG at 817-624-6600 or info@rotorcraftservices.com to notify Customer Support of needed RMA.</p> <p>2. Completely fill out this form, and email it to Customer Support, who will provide an RMA number. Print completed RMA form & place in the box with the item(s) being returned.</p> <p>3. Clearly mark the outside of the box with the RMA number.</p> <p>4. Ship the item(s) to: RSG Products, Inc. 440 West Ln., Suite 100 Saginaw, TX 76131</p> <p>Please refer to RSG's Warranty Policy and RMA Policy for complete details regarding product returns.</p>	Company Name			
	Address			
	City			
	State		Zip/Postal Code	
	Country			
	Phone Number			
	Contact Name			
	Email			
	Return Ship Method		Shipping Account Number	

Returned Item(s)					
Part Number / Serial Number	Quantity	Purchase Date	Invoice # or PO #	Reason for Return	Aircraft Tail # and Serial Number

Additional Comments:

*****You must submit a copy of the logbook page when items being returned were installed*****

Disposition (To be completed by RSG)

<i>Returned to customer, no problem found (eval fee applies)</i>		<i>Non-Warranty replacement (from stock-quote issued)</i>
<i>Warranty rebuild (rebuilt and returned to customer)</i>		<i>BER, Not rebuild-able, informed customer (eval fee applies, scrap?, RTC?)</i>
<i>Non-Warranty rebuild (quote issued - rebuilt and returned to customer)</i>		<i>Warranty Replacement (from stock-no fee applies)</i>
<i>Other:</i>		

RSG Products, Inc.
RMA (Return Material Authorization) Policy

All returns require an RMA number. Contact RSG Products (RSG) via telephone at 817-624-6600 or email at info@rotorcraftservices.com to obtain an RMA number. Returns will be authorized in accordance with the following policy: If it is deemed that the part should be returned, a representative from RSG will send you an RMA form. Completely fill out the RMA form and email it to Customer Support to obtain an RMA number. Once RMA is issued, place copy of RMA form, **and copy of logbook entries**, in the box with the item(s) being returned. Clearly mark the outside of the box with the RMA number. Products will not be accepted by RSG for return if not accompanied by a valid RMA number. Return shipping for all RMA items will be at the expense of the customer.

Stock Returns

Stock returns must be made within thirty (30) days of the invoice date. Authorization of stock returns is at the sole discretion of RSG. If a stock part is authorized for return and is a customer error, 25% of the purchase price will be applied as a standard restocking charge. Parts must be new, unused, and contain all the original packaging and paperwork (certs, 8130-3, packing slip...etc). There is no restocking fee due to errors by RSG if correct order information was furnished with the original order.

Warranty Returns

Products to be returned for warranty coverage must be within the applicable warranty period. If the customer requests that a replacement be sent immediately, a rebuilt-to-new unit (if available) will be shipped to the customer. If evaluation of the returned item shows damage or misuse, or if it is found in good working order, the replacement product will be billed to the customer's account in accordance with RSG's standard payment terms. Then, once a final decision of the return is made, a credit will be issued if the warranty claim is allowed.

Non-Warranty Returns

If the customer wishes to return a part for evaluation that is no longer within the warranty period or for damage not covered by the warranty, RSG will advise the customer of the estimated cost to rebuild-to-new. Return of the product, with a purchase order noting the quoted cost to rebuild will be considered authorization to proceed, and agreement to pay for the cost to rebuild, whether or not it exceeds the original estimate. A \$300 evaluation fee will apply to all non-warranty returns. This fee will be deducted from the total quoted to rebuild the part to new.

Transportation Charges

The customer is responsible for all transportation, insurance, duties and other similar charges for all returned items, and the customer must ensure that the product is appropriately packaged. Products shipped to RSG freight collect will be refused. Shipping damages resulting from improper packaging will be the customer's responsibility. After evaluation and/or rebuild, RSG will return the product using the method stated on the front of this form. Products will not be accepted by RSG for return if not accompanied by a valid RMA number, which must be clearly marked on the outside of the package.

RMA Closing Procedure

The RMA will be closed if RSG has not received the RMA requested items from the customer within (60) days of RMA assignment date.

Once returned parts are evaluated, if deemed non-rebuildable or BER, customer will be invoiced the \$300 evaluation fee. If customer does not respond within (60) days, RMA returned part will be scrapped on site by RSG or shipped back to the customer.

By choosing to request an RMA number from RSG, it is implied that the customer has agreed to the terms of this RSG RMA Policy.

Rev.	Desc.	Reviewed	Approved	Date
IR	Initial Release of New Document	K. Musgraves	G. Thompson	05/21/2022

RSG Products Inc.

440 West Ln, Suite 100, Saginaw, TX 76131

www.rotorcraftservices.com

Step 15

Trouble Shooting Guide

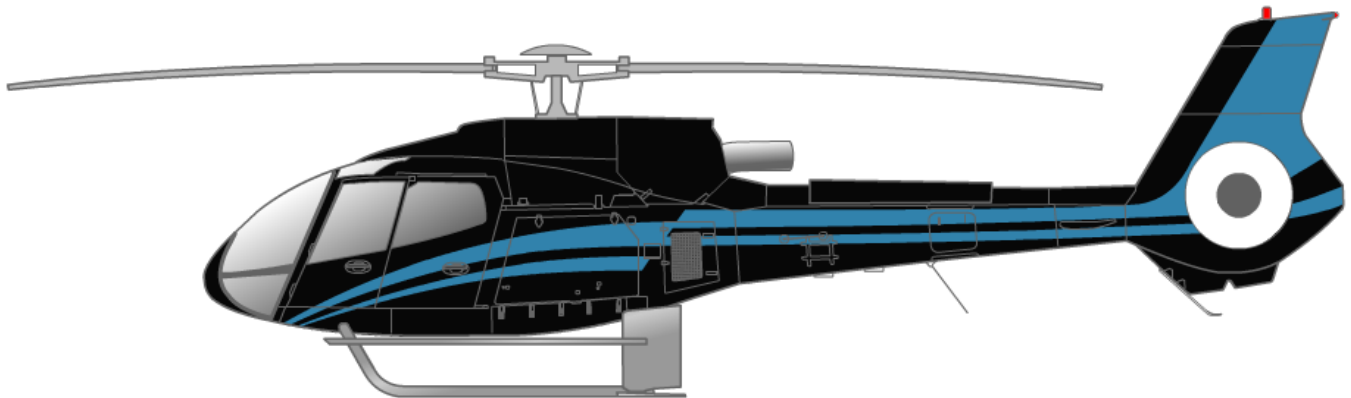

Servicing and Trouble Shooting Guide

AS350 (Series) and EC130 B4

Air Conditioning System

TROUBLESHOOTING YOUR AIR CONDITIONING SYSTEM

The following consists of some basic information on Freon System Operation.

We should probably define “cold”. Actually, for our purpose, “cold” is a relative term. Your air conditioner should produce air (measured at the duct) that is:

- • 36° to 50° F at 70° ambient temperature.
- • 40° to 52° F at 80° ambient temperature.
- • 46° to 60° F at 90° ambient temperature.
- • 50° to 75° F at 100° ambient temperature.

An Empty System

If the system is empty, the search for leaks should begin with a good visual check. Is it a fast leak or a slow leak? When was the system last charged? If it's a newly installed and filled system, then look for obvious leaks like a chaffed, punctured or ruptured hose, or a loose fitting. (See the recharge and leak testing section for hints on charging new systems.)

Freon leaks can be very tough to find. Freon is colorless, odorless, heavier than air, and it evaporates as soon as it hits the atmosphere. The only helpful thing about it is the fact that the oil carried with the refrigerant, so any sizable leak will leave a trail of oil at the offending hose or fitting. It will often just be a dark area, and the amount of oil might be slight. But if you find an air conditioning fitting with an oily residue and the area around it is dry, you've probably found your leak. A good electron detector can verify your visual diagnosis.

Because the system carries the oil in suspension with the refrigerant, any sizable leak will leak oil as well as refrigerant. Very slow leaks will usually only vent refrigerant and not oil, but a fast leak like a ruptured hose or a very loose fitting, will leak the refrigerant so fast that the oil is carried out of the system as well. If your system has suffered a major leak, be sure to check the oil level in the compressor before refilling the system.

Troubleshooting

Trouble: **Low or partial refrigerant charge**

Symptoms:

- Insufficient cooling
- Low-side pressure too low
- High-side pressure too low
- Receiver/drier sight glass shows a stream of bubbles
- Air in ducts only slightly cool

Cause: The system is low on refrigerant, probably caused by a leak.

Correction: Find and fix the leak. If there was a loss of oil, be sure to check the compressor oil level. Evacuate and recharge.

A System Full of Refrigerant

First, you should double-check all the obvious things (i.e. the compressor clutch, the belt tension, and the operation of the evaporator blower). Next, establish some baseline conditions for your testing: run aircraft, high blower and coldest thermostat setting, doors and windows closed, ambient temperature of 70° F or above.

Situations do occur where the system is full of refrigerant, yet the sight glass remains cloudy. The first thing to consider is whether the receiver/drier is installed backwards. Be sure the line from the condenser goes to the port marked "in" on the receiver/drier. The other condition that might give you a cloudy glass (on a full system) is a restriction in the liquid line from the condenser to the receiver/drier. On some new receiver/driers the filter screen could be pushed up so the bottom of the screen is blocking the liquid pickup tube. You will have to cut open the receiver-drier to confirm your diagnosis.

You should test next for a system that is overcharged. If the sight glass is clear, but the high- and low pressure gauge readings are high (300 or more on the high side, 50 or more on the low side), disconnect the compressor clutch. (Note that on HFC-134A systems, milky is the normal look for a correctly charged system.) The refrigerant should foam and then settle away from the glass in less than forty-five seconds. If the sight glass remains clear for more than forty-five seconds you have an overcharged condition and will have to remove Freon.

Trouble: Excessive moisture in the system

Symptoms:

- Insufficient cooling during hottest part of the day or during extended flying.
- Low-side pressure normal, though it may be too low or even a vacuum
- High-side pressure normal, though it may be low-at the same time low side is low
- Receiver-drier sight glass may show tiny bubbles
(*Note:* This could be a tough call with HFC-134A since the sight glass is always milky).
- Air in the ducts is usually cold, but becomes warm when pressure reading drop

Cause: Excessive moisture in the system. The drying agent in the receiver-drier is saturated with moisture, which is released to the system when outside temperature increased. Moisture in the system collects and freezes on the expansion valve, stopping the flow of refrigerant.

Correction: Suck all the CFC-12 from the system. Replace or rebuild the receiver-drier. Evacuate and recharge.

Trouble: Air in the system

Symptoms:

- Insufficient cooling
- Low-side pressure normal, but does not drop when the clutch cycles
- High-side pressure high
- Receiver/drier sight glass shows occasional bubbles (Note again that with HFC-134A the sight glass should be milky when the system is fully charged.)
- Air in ducts only slight cool

Cause: Refrigerant contains non-condensable in the form of air and moisture.

Correction: Leak test, watch for bad compressor seals. Drain the system. Repair leaks as needed. Replace or rebuild the receiver-drier. Check the compressor oil. Evacuate and recharge.

Trouble: Condenser malfunction or system overcharge

Symptoms:

- No cooling
- Low-side pressure too high
- High-side pressure too high
- Receiver/drier sight glass may show occasional bubbles
- Liquid line very hot
- Air in ducts is warm

Cause: The condenser is not function properly because of high head pressure. System may be overcharged.

(**Note:** Technicians will have to be especially careful to avoid overcharging HFC-134A systems. Because the sight glass is hard to read and the volume given is slightly lower with HFC-134A).

NOTE:

Cloudy Sight Glass

A cloudy sight glass indicates a system that is only partially full of refrigerant (with a few exceptions). A perfectly clear sight glass (use a light to get a good look) means the system is either full or empty. Note, with HFC-134A the glass appears milky when properly charged, and may show occasional bubbles.

AS350/B4 Trouble Shooting Guide



1. System has no electrical power to air conditioner master control box:
 - A) Check 50 amp circuit breaker or fuse in aircraft electrical bus.

2. System has power but will not turn on:
 - A) Check 5 amp circuit breaker on switch assembly.
 - B) Check ground lead on cannon plug 102 wire IFS105N20.
 - C) Check evaporator fan relay in air conditioner master control box.

3. Forward evaporator fan will not turn on, but aft fan runs:
 - A) Check 20 amp circuit breaker in master electrical box.
 - B) Check ground wire from evaporator motor.
 - C) AS350 disconnect CP104 and check for power on pin 2. On AS350 or EC130 B4 by checking ground lead from master switch.
 - 1) If you have power, your motor is bad.
 - 2) If no power, disconnect CP101 cannon plug and check continuity from pin 6/c on CP101 to cannon plug CP104 pin 2. If no power, check cannon plugs and switch.

4. Aft evaporator fan will not run, but forward evaporator runs:
 - A) Check 20 amp circuit breaker on master electrical box.
 - B) Check ground wire from fan.

AS350/B4 Trouble Shooting Guide



5. Condenser fan/fans do not operate:

- A) Check 20 amp circuit breaker.
- B) Check 1 amp circuit breaker.

- 1) If popped, reset.
 - a) Check brushes.
 - b) Check power.
 - c) Check ground.
 - d) Check fins for blockage in air condenser assembly.
- 2) Run air conditioning system.
 - a) Check pressures, If pressure is running higher than normal, then continue with b), ect...
 - b) System may be over-serviced.
 - c) System may be contaminated by improper Freon or a mix of Freon's.

- 1) **NOTE:** This has happened more than once. The service carts are great for servicing systems, but there is a danger in its misuse. Untrained operators or an individual who wants to service his car, truck, motor home or even his room A/C can pump down their system into your tank. It can have any number of different Freon's. It could also be contaminated by a failed compressor, dryer bottle, wrong oil or any number of things. This has happened to a company with brand new equipment just 3 weeks old. There were large warning signs on this service cart, designated HELICOPTER SERVICE ONLY. They had one for ground equipment. All of the mechanics were well trained except for the management, janitors and their family members of the company. It can happen to any operator.

6. Compressor clutch does not engage, but air conditioner fans work.

- A) Check clutch for power.

- 1) If power, clutch coil may be bad or air gap in clutch face may be too excessive.
- 2) If NO power check system for total Freon loss.
- 3) If system is serviced and still no Power and you have an optional temperature controller, you can bypass by jumping pins 3 and 4 on CP102 to check if faulty.

AS350/B4 Trouble Shooting Guide



7. System not cooling:
 - A) Check that air condenser fan/fans are blowing.
 - B) Check clutch engagement. Is clutch staying engaged or cycling? Check belt tension.
 - C) Check to see if air condenser coil is free from debris and fins are clean and not rolled over blocking air flow.
 - D) Check evaporator return air inlets, that they are not blocked and fins are clean and not rolled over blocking airflow.
 - E) Put gauges on system. Run system and check pressures also measure Delta temperature from both evaporators. (Measure inlet temperature and outlet temperature to get Delta. This is a must, do not rely on just using your hand and guessing).
 - F) Check sight glass.

(NOTE: There are several ways to service Freon systems:

- 1) Service system to a clear sight glass R12.
Note: On 134a systems the sight glass appears milky when properly charged, though there may be occasional bubbles in the sight glass.
- 2) Service system by weight. If you have a service station or scale, you can add the proper amount by weight.

82° F or higher service with 2.0 lbs max Freon.

Below 82° F service with 2.5 lbs max Freon.

- 3) The optimum method for best performance is to use at least two mechanical thermometers and place them near the return air and the discharge air of each evaporator. R-134a can then be added or deleted as required, until the highest T.D. is noted per the paragraph below. At that time, the correct amount of refrigerant is installed. At any time the high pressure gauge reaches 280 psi, stop servicing. Do not exceed 3.0 lbs of refrigerant..
 - 4) Service according to a standard pressure temperature chart.)
8. One evaporator is cooling, one is not.
 - A) One expansion valve may be blocked from contamination.
 - B) One expansion valve may be locked full open.
(NOTE: The one valve that is full open is causing the problem. It may make it seem like the other valve is bad and not working.)
 - C) One of the sensing bulbs on expansion valves may become loose from suction side of coil. Also check to see if sensing bulb is mounted to the correct evaporator tube. The bulb should be mounted at 9 or 3 o'clock position.
 - D) Hose may be crimped, kinked or have a fitting bent over blocking flow.
 - E) (NOTE: The recommended fix is to pump down system. Change BOTH expansion valves and dryer bottle. Make sure to mount sensing bulb on suction side of coil and when possible at 9 or 3 o'clock position on tube. Re-service system.)

AS350/B4 Trouble Shooting Guide



9. Compressor clutch failure:

- A) Low Freon in system. This causes the system to low pressure out through the low pressure switch. It will cycle the clutch on and off until it heats up causing the coil to overheat and fail, or heat up the bearing to the point the grease will liquefy and run out. This will add to the heat and help fail coil or bearing.
- B) Air gap on clutch may have changed.
- C) Coil may have weakened.
- D) Bearing may have failed, causing clutch to slip and fail coil.
NOTE: If ongoing maintenance is not maintained on compressor clutch bearing as prescribed in IFS maintenance manual, bearing may fail.

10. Compressor failed:

- A) Loss of oil or insufficient oil.
- B) Low Freon in system, causing insufficient flow of oil lubricant.
- C) Contamination in system.
- D) Compressor bearing failed.
- E) Over servicing of system to the point of liquid lock.
(NOTE: This has happened.)

11. Compressor belt failure:

- A) Low Freon in system. Cause: low pressure switch to cycle the clutch on and off excessively.
- B) Insufficient belt tension.
- C) Clutch bearing dragging or failing. This causes excessive belt slipping.
- D) Over service of system.
- E) Air gap excessive, causes clutch to slip heating pulley. This will stretch belt making it slip.

12. Air conditioner runs, but pops 1 amp circuit breaker:

- A) Check condenser fan or fans for operation.
- B) Check blockage of air flow in and out of condenser.
- C) Check coil to see if fins are clean or rolled over.
- D) Check for over service of Freon.
- E) Put gauges on and run system.
 - 1) Is system popping 1 amp circuit breaker at 350 or higher?
 - a. If not change high pressure switch.
- F) Check expansion valves and make sure sensing bulbs are mounted to suction lines.
 - 1) Measure Delta of both evaporators.
 - a. If Delta is over 32° F expansion valve may not be working. If expansion valve is not throttling it will dump too much Freon. This can add excessive heat to condenser and can also freeze up coil.
 - 2) If Delta is below 14° F. Change valves, they may be blocked internally.

AS350/B4 Trouble Shooting Guide



13. Fresh air supply valve inoperable. EC130 B4 only

A) If valve fails to open.

- 1) Check 2 ½ amp CB
- 2) Check for power at wire IFS 104V20
 - a. If power, check for power on wire IFS 104E20
 1. If no power motor/controller is bad
 2. If power trace back to source
 - b. If no power check continuity to Pin 1 on cannon plug CP101.
 - c. If no continuity check low pressure switch for ON.

B) If valve fails to close

- 1) Check for power on wires at valve IFS 104V20 and IFS 104E20
 - a. If power, both motor /controller is bad.
 - b. If no power on wire IFS 104V20.
 - a. Check 2 ½ amp CB.
 - b. Check to see if low pressure switch is open.
 - c. Check continuity from valve wire IFS 104V20 to Pin 1 on cannon plug CP101.

NOTE:

When running in “A/C” mode and you switch straight to “OFF” the Fresh Air Valve will stay in the closed position. You will need to switch to the “Fan” position to reset the Fresh Air valve to the open position.

SERVICE OPERATIONS CLUTCH

14.1 Armature Assembly Removal

1. If armature dust cover is present, remove the 3 or 6 bolts holding it in place and remove cover. If auxiliary sheet metal pulley is present, remove the screws holding it in place. Then remove pulley.
2. Insert pins of armature plate spanner into threaded holes of armature assembly.
3. Hold armature assembly stationary while removing retaining nut with 3/4", 19mm, or 14mm socket wrench, as appropriate.
4. Remove armature assembly using puller. Thread 3 puller bolts into the threaded holes in the armature assembly. Turn center screw clockwise until armature assembly comes loose.
5. If shims are above shaft key, remove them now. If shims are below shaft key, the key and bearing dust cover (if present) must be removed before the shims can be removed.
6. Remove bearing dust cover (if present). Use caution to prevent distorting cover when removing it.
7. Remove shaft key by tapping loose with a flat blade screwdriver and hammer.
8. Remove shims. Use a pointed tool and a small screwdriver to prevent the shims from binding on the shaft.

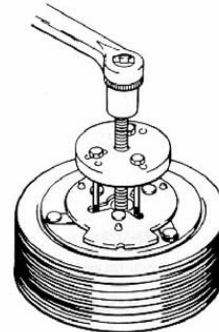
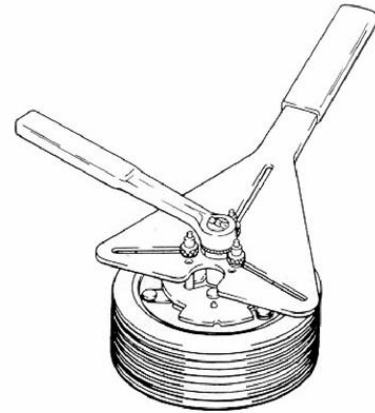

SERVICE OPERATIONS - CLUTCH

14.2. Rotor Assembly Removal

1. If bearing dust cover has not been removed, remove it now. See step 6 of Section 14.1, for Armature Assembly Removal.
2. If internal snap ring for bearing is visible above the bearing, remove it with internal snap ring pliers.
3. Remove rotor snap ring.
4. Remove shaft key.
5. Remove rotor pulley assembly:
 - Insert the lip of the jaws into the snap ring groove
 - Place rotor puller shaft protector (Puller set) over the exposed shaft.
 - Align thumb screws to puller jaws and finger tighten.
 - Turn puller center bolt clockwise using a socket wrench until rotor pulley is free.

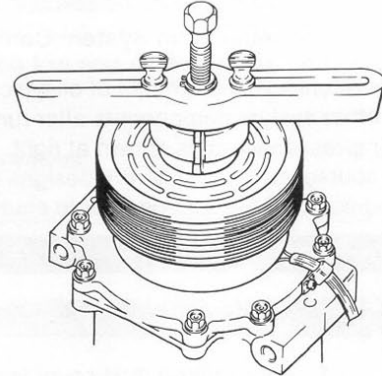

14.3 Field Coil Assembly Removal

1. Loosen lead wire clamp screw with #2 Phillips screwdriver until wire(s) can be slipped out from under clamp.
2. Undo any wire connections on the compressor which would prevent removal of the field coil assembly.
3. Remove snap ring.
4. Remove the field coil assembly.

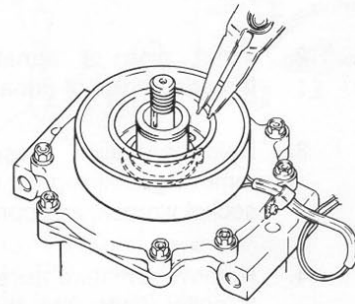

14.4 Field Coil Assembly Installation

Reverse the steps of Section 14.3. Protrusion on underside of coil ring must match hole in front housing to prevent movement and correctly locate lead wire(s).

14.5 Rotor Assembly Installation

1. Place compressor on support stand, supported at rear end of compressor. If the compressor must be clamped in a vice, clamp only on the mounting ears, never on the body of the compressor.
2. Set rotor squarely over the front housing boss.
3. Place the rotor installer ring into the bearing bore. Ensure that the edge rests only on the inner race of the bearing, not on the seal, pulley, or outer race of the bearing.

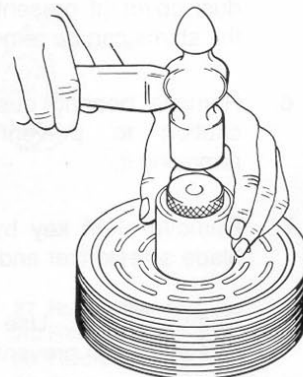

SERVICE OPERATIONS - CLUTCH

4. Place the driver into the ring and drive the rotor down onto the front housing with a hammer or arbor press. Drive the rotor against the front housing step. A distinct change of sound can be heard when using a hammer to install the rotor.
5. Reinstall rotor bearing snap ring, if it has been removed, with internal snap ring pliers.
6. Reinstall rotor retaining snap ring with external snap ring pliers. If a bevel is present on the snap ring, it should face up (away from the body of the compressor).
7. Reinstall rotor bearing dust cover (if present) by gently tapping it into place.

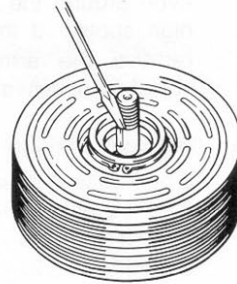

14.6 Armature Assembly Installation

1. Install shaft key with pliers.
2. Install clutch shims. NOTE: Clutch air gap is determined by shim thickness. When installing a clutch on a used compressor, try the original shims first. When installing a clutch on a compressor that has not had a clutch installed before, first try 0.04", 0.02", and 0.004" (1.0, 0.5, 0.1 mm) shims.
3. Align keyway in armature assembly to shaft key. Using driver and a hammer or arbor press, drive the armature assembly down over the shaft until it bottoms on the shims. A distinct sound change will be noted if driving with a hammer.
4. Replace retaining nut and torque to specification.
1/2-20: 20-25 ft•lb (27-34 N•m, 270-350 kg•cm)
M8: 11-15 ft•lb (15-21N•m, 150-210kg•cm)

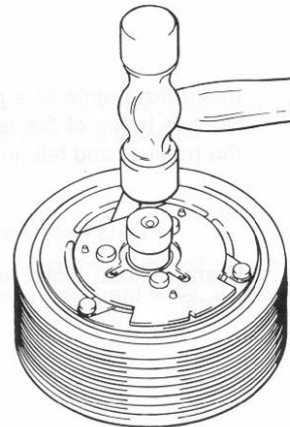
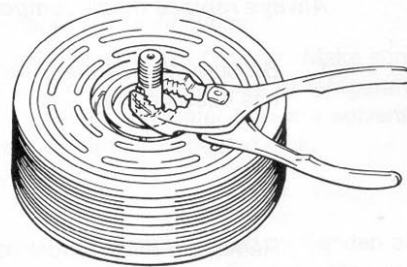

SERVICE OPERATIONS - CLUTCH

5. Check air gap with a feeler gauge. Specification is 0.011" - 0.019" (0.3 - 0.5mm). If gap is not even around the clutch, gently tap down at the high spots. If the overall gap is out of spec., remove the armature assembly and change shims as necessary.

6. Replace armature dust cover (if used) and torque 3 or 6 bolts to specification below.
3 - 1/4-20 bolts (SD-5): 2-4 ft•lb
(2-5 N•m, 25-50 kgf•cm)
6 - M5 bolts (SD-7): 5-8 ft•lb
(7-11 N•m, 70-110 kgf•cm)

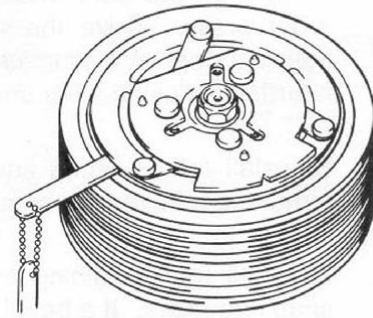

Note: Over torque of SD508/5H14 dust cover bolts will cause air gap to become out of spec.

REVISION RECORD				
DWG REV LTR	DATE	DESCRIPTION OF CHANGE	APPVD BY	REV BY

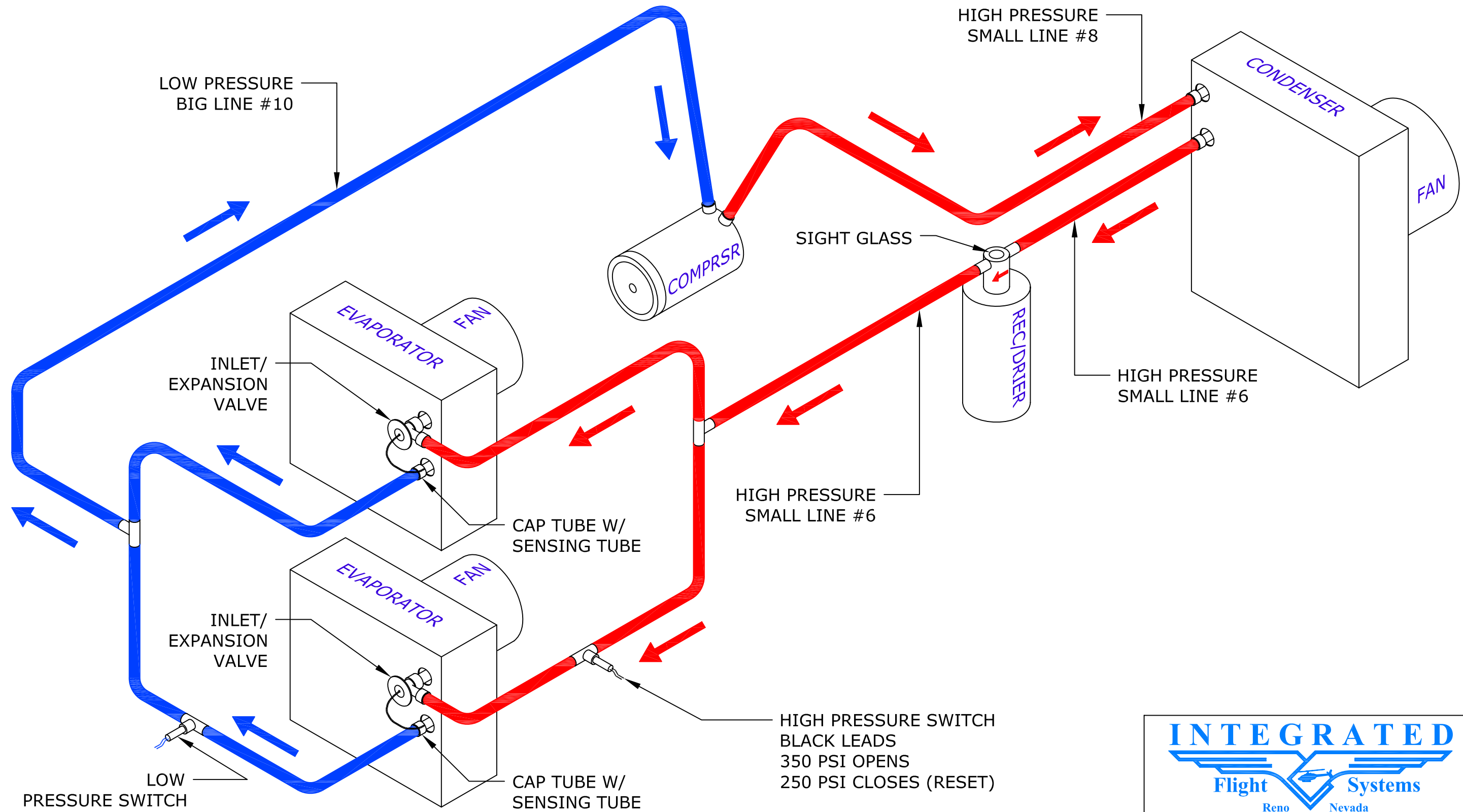

INTEGRATED
Flight Systems
Reno Nevada

TITLE: SIMPLE AIR CONDITIONING SCHEMATIC

DRAWN BY: JTJE	DATE: 04/10/06	REV: -	SCALE: NONE	SHEET: 1 OF 1
APPLICATION: N/A			DWG No. A/C SCHEMATIC	