

ASG

PRODUCTS INC.

Air Conditioning System Installation

Instructions for Continued Airworthiness
for
Airbus Helicopters AS-350 B, C, D, D1, B1, B2, B3, BA &
EC-130 B4

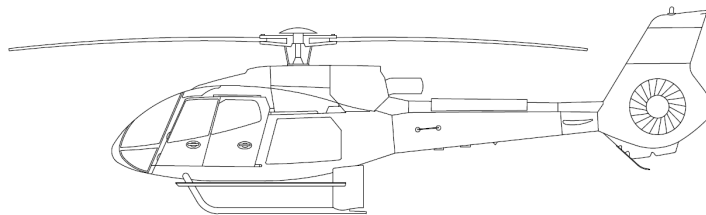
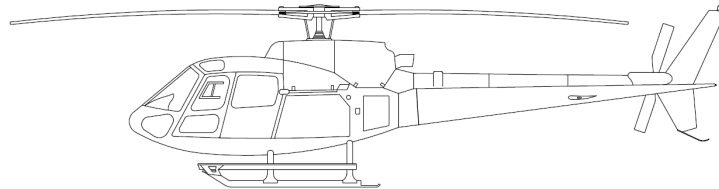

FAA Project Number: SA3109RC-R
STC Number: SH3509SW



DATE:
04/25/2025

DOC No.:
IFSE-0007

REV:
G

PAGE:
ii of vii

TITLE:
Air Conditioning System Installation Instructions For Continued Airworthiness for Airbus Helicopters AS-350 B, C, D, D1, B1, B2, B3, BA & EC-130 B4

LOG OF REVISIONS

Instructions for Continued Airworthiness for the Airbus Helicopters AS-350 B, C, D, D1, B, B1, B2, B3, BA and EC-130 B4 Air Conditioning System Installation have been reviewed and found to be acceptable to the Administrator. For the purpose of these Instructions for Continued Airworthiness (ICA), acceptable to the Administrator means the ICA contains the applicable requirements specified in Appendix A to Federal Aviation Regulations Part 27, as appropriate, do not contain any incorrect terminology or incorrect references, and contain a Cover Page, Log of Accepted Revisions, Revision Control Procedure and Record of Temporary Revisions, a list of Effective Pages, and a Table of Contents. Changes to this document will be distributed to owners of the kits within 10 days after the revision is approved. Changes to this document will be indicated by a revision letter in the header, in the Record of Revisions, and on the List of Effective Pages. Contact RSG Products by mail at 440 West Lane Suite 100, Saginaw, TX, 76131. Or by phone at 817-624-6600.

REV	Date	Description	Written By	Checked By	FAA Approval	Approval Date
-	05/03/10	Original Issue	E. Sherrill	P. Ban		
A	06/11/10	Incorporated FAA redlines	E. Sherrill	K. Sheridan		
B	08/08/10	Revised to add Brushless Motor part information, page 87	E. Sherrill	P. Ban		
C	08/12/10	Incorporated FAA redlines	E. Sherrill	P. Ban		
C-1	12/11/13	Revised Chapter 5, 100 hour inspection to change belt on condition. Changed Name.	A. Weidler	S. Weidler		
C-2	09/17/14	Revised Chapter 12 and 21. Removed paragraphs 7 - 9 of Section 12-10-02.d. Removed sight glass troubleshooting information Section 21-00-06 under symptoms.	A. Cuellar	S. Weidler		
C-3	09/30/14	Revised chapter 5 to increase inspection interval to 150 Hours +/- 15	S. Weidler	S. Weidler		
D	11/19/14	Changed Template. Changed Mfr. Name. Was: Eurocopter, Is: Airbus Helicopters. Updated parts list with newer configurations. Parts list is now	S. Johnson	S. Thornton		



DATE:
04/25/2025

DOC No.:
IFSE-0007

REV:
G

PAGE:
iii of vii

TITLE:
Air Conditioning System Installation Instructions For Continued
Airworthiness for Airbus Helicopters AS-350 B, C, D, D1, B1, B2, B3, BA &
EC-130 B4

		under Chapter 31. Updated electrical and plumbing diagrams and install drawings. Updated annual/150-hour inspection program in sections 05-00-00 and 05-10-00.				
E	01/12/17	Remove 50 hour inspection table and added Component Overhaul/Replacement schedule for blower motors. Remove, add and update images for Sections 11-00-00, 21-00-00, & 21-10-00	A. Cuellar	S. Weidler		
F	01/19/22	Update to include changes made for MDL Rev U. Change amount of refrigerant to paragraph 1 and 5 on page 18 of 99. Added acceptance criteria to table 5-01 item 8	S. Brewer	K. Musgraves		
F-1	08/04/23	Change time delay of "4 to 8 seconds" to "15 seconds" on page 28 of 99. Updated Weight and Balance information on pages 97, 98 and 99 of 99. Update also includes changes made for MDL Rev V.	S. Brewer	K. Musgraves		
G	04/25/25	Update Pg. 74 050006 to include model EC130. Update drawing on Pg. 94 from revision D to revision E.	S. Brewer	K. Musgraves		

Typed signatures indicate approval. Handwritten signature approvals of this document are on file at RSG Products Inc.



DATE:
04/25/2025

DOC No.:
IFSE-0007

REV:
G

PAGE:
v of vii

TITLE:
Air Conditioning System Installation Instructions For Continued
Airworthiness for Airbus Helicopters AS-350 B, C, D, D1, B1, B2, B3, BA &
EC-130 B4

LIST OF EFFECTIVE PAGES

LIST OF REVISIONS	Revision A Revision B Revision C Revision D Revision E Revision F	December 06, 2012 February 27, 2013 May 14, 2013 November 19, 2014 January 12, 2017 January 19, 2022
-------------------	--	---

LIST OF EFFECTIVE PAGES

<u>TITLE</u>	<u>PAGES</u>	<u>REV.No</u>
Cover	i	D
Log of Revisions	ii	D
Record of Temporary Revisions	iv	D
List of Effective Pages	v	D
Table of Contents	vi - vii	D
Chapter 1 Introduction	1	D
Chapter 4 Airworthiness Limitation	2	D
Chapter 5 Continued Airworthiness Inspections and Overhaul	3 - 9	E1
Chapter 6 Dimensions and Access	10 - 12	D
Chapter 11 Markings and Placards	13	E
Chapter 12 Servicing Maintenance Practices	14 - 30	D
Chapter 20 Standard Practices	31 - 43	E1
Chapter 21 Air Conditioning	44 - 59	E
Chapter 31 Illustrated Parts List	60 - 83	D
Chapter 98 Wiring Diagrams and Plumbing Schematics	84 - 96	D
Appendix A Weight and Balance	97 - 99	D



DATE:
04/25/2025

DOC No.:
IFSE-0007

REV:
G

PAGE:
vi of vii

TITLE:
Air Conditioning System Installation Instructions For Continued
Airworthiness for Airbus Helicopters AS-350 B, C, D, D1, B1, B2, B3, BA &
EC-130 B4

Table of Contents

LOG OF REVISIONS	ii
RECORD OF TEMPORARY REVISIONS	iv
LIST OF EFFECTIVE PAGES	v
Chapter 1	1
Section 01-00-00 Introduction	1
Chapter 4	2
Section 04-00-00 Airworthiness Limitations	2
Chapter 5	3
Section 05-00-00 Continued Airworthiness Inspection	3
Section 05-10-00 Continued Airworthiness Scheduled Inspection	6
Chapter 6	10
Section 06-00-00 Dimensions and Access	10
Chapter 11	13
Section 11-00-00 Placards and Markings	13
Chapter 12	14
Section 12-00-00 Servicing Maintenance Practices	14
Section 12-10-00 Charging Practices	15
Section 12-20-00 Clutch Servicing Practices	20
Section 12-30-00 System Leak Check	26
Section 12-40-00 Fitting Torque Procedures	27
Section 12-50-00 Normal Operation Functional Test	28
Section 12-60-00 Belt Tension Procedure	29
Section 12-70-00 Drive Belt Change Procedure	30
Chapter 20	31
Section 20-00-00 Standard Practices	31
Section 20-10-00 Torques Maintenance Practices	32
Section 20-30-00 Painting Maintenance Practices	37



DATE:
04/25/2025

DOC No.:
IFSE-0007

REV:
G

PAGE:
vii of vii

TITLE:
Air Conditioning System Installation Instructions For Continued
Airworthiness for Airbus Helicopters AS-350 B, C, D, D1, B1, B2, B3, BA &
EC-130 B4

Section 20-40-00 Corrosion Control Maintenance Practices	38
Section 20-50-00 Mechanical Fastener Sealing Methods.....	42
Section 20-90-00 Dye-Penetrant Inspection Methods	43
Chapter 21	44
Section 21-00-00 Air Conditioning.....	44
Section 21-10-00 Illustrated Parts List	60
Chapter 98	84
Section 98-00-00 Wiring Diagrams and Plumbing Schematics.....	84
APPENDIX A Weight and Balance	96



DATE:
04/25/2025

DOC No.:
IFSE-0007

REV:
G

PAGE:
1 of 99

TITLE:
Air Conditioning System Installation Instructions For Continued Airworthiness for Airbus Helicopters AS-350 B, C, D, D1, B1, B2, B3, BA & EC-130 B4

Chapter 1

Section 01-00-00 Introduction

These are accepted Instructions for Continued Airworthiness for modifications performed in accordance with the Airbus Helicopters AS-350 B, C, D, D1, B, B1, B3, BA and EC-130 B4 Belt-Driven Vapor Cycle Air Conditioning System Installation. All references to the Air Conditioning System in this document will refer to the Belt-Driven Air Conditioning System Installation and other related components specified in STC – SH3509SW. Whether modified by Rotorcraft Services Group or by another Agency with expressed permission from RSG these Instructions for Continued Airworthiness (ICA) should be supplied to the owner/operator of the STC at the time of completion. Subsequent accepted changes to the ICA will be submitted by Rotorcraft Services Group for distribution to owners and operators of the STC.

This, Instructions for Continued Airworthiness, is intended to supplement the AS-350 B, C, D, D1, B, B1, B2, B3, BA, and EC-130 B4 rotorcraft maintenance manuals provided by Airbus Helicopters. The information, procedures, requirements, and limitations contained in this, Instructions for Continued Airworthiness, for this type design change supersede the information, procedures, requirements, and limitations contained in the rotorcraft's maintenance manual when the type design change is installed on the Type Certificate Holder's rotorcraft.



DATE:
04/25/2025

DOC No.:
IFSE-0007

REV:
G

PAGE:
2 of 99

TITLE:
Air Conditioning System Installation Instructions For Continued
Airworthiness for Airbus Helicopters AS-350 B, C, D, D1, B1, B2, B3, BA &
EC-130 B4

Chapter 4

Section 04-00-00 Airworthiness Limitations

“The Airworthiness Limitations section is FAA approved and specifies inspections and other maintenance required under §§43.16 and 91.403 of the Federal Aviation Regulation unless an alternative program has been FAA approved.”

There are no additional airworthiness limitations associated with the Air Conditioning System Installation.

There are no life limited components associated with the Air Conditioning System Installation.

Chapter 5

Section 05-00-00 Continued Airworthiness Inspection and Overhaul

1. General

This chapter contains time limit intervals for the Component Overhaul Schedule and Scheduled Inspection for the Air Conditioning System. This chapter is to be added to the approved scheduled inspection for the rotorcraft.

2. Component Overhaul Schedule & Scheduled Maintenance Practices

This chapter describes the inspection that must be accomplished on the Air Conditioning System Installation at Scheduled Inspection intervals. Scheduled Inspection requirements must be complied with at the hourly and/or calendar time intervals specified. Refer to Tables 5-01 and 5-02, in Section 05-10-00 for hourly and/or calendar inspection schedules.

3. Conditional Inspection

After any operational incident involving hard landings, sudden stoppage of the drive train or water immersions the system must not be operated and an Annual or 150 flight hour inspection is required.

4. Documentation

Aircraft mechanics, owners, or operators are required to keep records of the aircraft systems inspections and repairs. This includes, but is not limited to, airworthiness directives, service notices, scheduled inspections, records and life limited components.

5. Definitions

The following is short descriptions of words and terms used in the procedures for the required scheduled inspections.

- **Ambient air temperature:** The temperature of the air surrounding a person.
- **Charging station:** An air conditioning system service.
- **Cold:** The absence of heat.
- **Condensation:** The process of changing a vapor into a liquid.
- **Condition:** The state of an item or component compared to a known standard.



DATE:
04/25/2025

DOC No.:
IFSE-0007

REV:
G

PAGE:
4 of 99

TITLE:
Air Conditioning System Installation Instructions For Continued
Airworthiness for Airbus Helicopters AS-350 B, C, D, D1, B1, B2, B3, BA &
EC-130 B4

- **Damage:** Physical deterioration of a component.
- **Desiccant:** A material used in the receiver/dryer bottle, to absorb moisture from the refrigerant.
- **Evaporate:** To change from a liquid into a vapor.
- **Examine:** Look carefully to find the condition of the component. Find how that condition is related to a specific standard.
- **Heat load:** The amount of heat which the air conditioner is required to remove from the aircraft cabin.
- **Inches of Mercury:** A measurement of pressure normally used for pressures below atmospheric, one i-h of mercury is equal to approximately one-half pound per square i-h.
- **Inspection:** A procedure that includes checking, inspecting and examining a system or component.
- **Maintenance:** The servicing and/or repair of a rotorcraft, a system or a component that keeps it serviceable.
- **Pressure, ambient:** The pressure of the air surrounding a body, normally measured in Pounds per Square i-h, or PSIG.
- **Refrigerant:** A fluid which is used in an air conditioning system to absorb heat from the cabin and carry it outside the helicopter where it can be transferred to the outside air.
- **Relative Humidity:** The ratio of the amount of water vapor in the air to the amount of water vapor required to saturate the air at the existing temperature.
- **Scheduled Inspection:** An inspection procedure that must occur at a specified calendar interval or at specific operational time intervals. Scheduled Inspections are required to help ensure the rotorcraft stays airworthy.
- **Security:** Term used for inspection of hardware and components to make sure they are properly attached and tightened.
- **Temperature Differential:** Difference in temperature.
- **Thermostat:** An air condition control which senses the temperature of the evaporator coil and causes the system to cycle or by-pass to maintain the proper temperature of cooling air.
- **Vacuum:** A negative pressure, or pressure below atmospheric; it is usually expressed in inches of mercury.
- **Vapor:** The gaseous state of a material.



DATE:
04/25/2025

DOC No.:
IFSE-0007

REV:
G

PAGE:
5 of 99

TITLE:
Air Conditioning System Installation Instructions For Continued
Airworthiness for Airbus Helicopters AS-350 B, C, D, D1, B1, B2, B3, BA &
EC-130 B4

6. Abbreviations:

- **ICA:** Instructions for Continued Airworthiness
- **TD:** Temperature differential
- **In:** Inches
- **InHg:** Inches of Mercury
- **lbs:** Pounds
- **oz:** Ounces
- **Psig:** Pounds per Square I-h (gauge)
- **gr:** Grams
- **kg:** Kilograms
- **kgcm:** Kilograms Per Centimeter
- **ml:** Milliliters
- **mm:** Millimeters
- **N-m:** Newton-meters



DATE:
04/25/2025

DOC No.:
IFSE-0007

REV:
G

PAGE:
6 of 99

TITLE:
Air Conditioning System Installation Instructions For Continued
Airworthiness for Airbus Helicopters AS-350 B, C, D, D1, B1, B2, B3, BA &
EC-130 B4

Section 05-10-00 Continued Airworthiness Scheduled Inspection

1. General

This section contains requirements for scheduled inspection.

2. Scheduled Inspection Program

The Air Conditioning System Installation requires one scheduled inspection in order to maintain continued airworthiness. Every effort should be made to perform the inspection with the aircraft placed in a clean well-lit environment.

a) Annual or 150-Hour Inspection

The inspection is required to be performed annually or every 150 hours of rotorcraft time-in-service, whichever comes first, +15 hours not to exceed 165 hours. If inspection is overflowed beyond 165 hours then overflowed time must be deducted from the next inspection due. Inspection Table 5-01 specifies the requirements of the annual inspection.

b) Component Overhaul/Replacement Schedule

The blower manufacturer recommends TBO at 1000 hours.
A blower failure will result in a reduction in cooling, but no safety-of-flight issues are involved. Component Overhaul/Replacement Schedule Table 5-02 specifies the requirements of overhaul/replacement hours.

3. Tools and Special Tools for Scheduled Inspection

Although not necessarily considered special tools, the adjustable ball swivel mirror and bright flashlight and / or drop light are standard requirements for doing inspections. These items should be used freely and frequently to enhance inspection quality and help ensure discrepancies are not missed. It is important to have adequate lighting for all phases of the inspection.

The special tools necessary for the Air Conditioning System Installation inspection are listed as follows:

- a) Vacuum Pump
- b) Gauge Manifold
- c) Vacuum Cleaner
- d) Pull Scale



DATE:
04/25/2025

DOC No.:
IFSE-0007

REV:
G

PAGE:
7 of 99

TITLE:
Air Conditioning System Installation Instructions For Continued
Airworthiness for Airbus Helicopters AS-350 B, C, D, D1, B1, B2, B3, BA &
EC-130 B4

Table 5-01 Annual or 150 – Hour Inspection

Registration No.	Serial No.	Helicopter Total Hours
<ul style="list-style-type: none"> The inspection shall be accomplished annually or every 150 hours of rotorcraft time-in-service, whichever comes first, + 15 hours not to exceed 165 hours. If inspection is overflowed beyond 165 hours then overflowed time must be deducted from the next inspection due. Initial each item after accomplishing the inspection. Record all findings and attach a copy of findings to this inspection form. After correction of all findings, make maintenance record entry. 		
PRE-INSPECTION		Initial
1. Review Airworthiness Directives.		
2. Review records for the Air Conditioning System.		
3. Review log books for discrepancies.		
INSPECTION		Initial
1. Perform an operational test of the system in accordance with Section 12-50-00		
2. Inspect the condition of the belt for cracks, deterioration, separation and worn or flat spots. Change belt if necessary. Check belt for proper tension (Ref. 12-60-00 Belt Tension).		
3. Inspect the compressor for a true turning and free clutch. One mechanic should turn the main rotor blade while another observes the belt and clutch faceplate. Turn system to "A/C" and check magnetic operation of clutch faceplate. Inspect compressor ground wire for condition and conductivity. If clutch plate and pulley show signs of excessive heat, replace clutch pulley assembly, bearing and coil (Ref. Section 12-20-00 Clutch Servicing Procedures)		
4. Inspect the compressor clutch bearing. It is not mandatory to grease the bearing. If the bearing is greased use a hypodermic needle, without removing the bearing using 3 to 5cc of Mobil 28 grease. This has proven to be satisfactory when performed at regularly scheduled inspections of 500 hours. Some operators flying as much as 200 hours per month have found that re-greasing can occur at more than 500-hour intervals, provided they DO NOT OVER PACK THE BEARING. 100% capacity packing of the bearing can cause a failure to occur in 1 to 1 ½ hours.		
5. Inspect hoses for general condition, cuts or swelling. Replace as required.		
6. Check for security of all plumbing fittings (Ref. Section 12-40-00 Fitting Torque Procedures). Replace fittings as needed. Check security of clamps and anti-chaff material. Perform system leak check (Ref. 12-30-00 System leak check).		



DATE:
04/25/2025

DOC No.:
IFSE-0007

REV:
G

PAGE:
8 of 99

TITLE:
Air Conditioning System Installation Instructions For Continued
Airworthiness for Airbus Helicopters AS-350 B, C, D, D1, B1, B2, B3, BA &
EC-130 B4

7. For brushed motors only, access the Aft Evaporator (Ref. Section 6-00-00 Dimensions and Access). Aft evaporator motor has two (2) removable brushes. Detach elbow from top of blower assembly. Remove brushes one (1) at a time. Note position relative to curvature of armature. Inspect brush for wear. Replace if brush is 5/16" or less. Install new brushes and run at 12 VDC (utilizing an independent power source).

Until seating occurs on 70% of the surface (this should be accomplished with motor assembly removed from aircraft). This action will greatly enhance brush life. Reconnect wires to aircraft system and reinstall insulated duct. Run both of the blower/fans in the "FAN" position and perform visual inspection of the assemblies to see that foreign materials have not been ingested into the blower/fan, which might cause blade damage. The blower/fan should also be run at the various speeds available to check the motor operation.

8. Access the condenser (Ref. Section 6-00-00 Dimensions and Access). Check the fins of the condenser coil for cleanliness and ensure that they are straight. If damage has occurred to the fins, a fin comb should be utilized to put them in like new condition. If damaged fins that cannot be straighten account for $\leq 3\%$ of the overall fin-covered surface area of the condenser, the operation of the condenser will remain unaffected.



DATE:
04/25/2025

DOC No.:
IFSE-0007

REV:
G

PAGE:
9 of 99

TITLE:
Air Conditioning System Installation Instructions For Continued
Airworthiness for Airbus Helicopters AS-350 B, C, D, D1, B1, B2, B3, BA &
EC-130 B4

Table 5-02 Component Overhaul/ Replacement Schedule

Description	Part Number	Overhaul/Replacement Hours
Aft Evaporator Blower Motor	490017-1-01 (IFSS 050143-3 DCB) 490017-1-02 (IFSS 050143-2 DCB)	The blower manufacturer recommends TBO at 1000 hrs. At the discretion of the operator, it is acceptable to operate the blower until failure. A blower failure will result in a reduction in cooling, but no safety-of-flight issues are involved.
Condenser Blower Motors	IFSS 050143-3 DCB or IFSS 050084-7-2 & IFSS 050084-7-3	Same as above

Chapter 6

Section 06-00-00 Dimensions and Access

1. Access Methods

a) Access Item Identification (Ref. figures 6-01 & 6-02)

- **Condenser-** The condenser is located in one of two positions depending on kit part number (Ref. Section 21.00.00 System Description). The aft mounted condenser (Kit numbers 350-00-031HP and 130-00-031HP) (Ref. figure 6-02) is mounted in the tail boom mounted 5 in. above the baggage floor and is accessed by removing the tail boom closeout panel. The side mounted condenser (Kit Number 350-00-011HP) is located in the right baggage compartment (Ref. figure 6-01) and is accessed by removing to baggage compartment close out panel.
- **Compressor-** The compressor is located aft and to the left side on main transmission deck. It is accessed by opening the upper transmission cowling.
- **Aft Evaporator-** The aft evaporator is located on the right-hand upper transmission deck in all configurations. It is accessed by opening the right-hand transmission cowling forward latch.
- **Forward Evaporator-** In the AS-350 series, the forward evaporator is located on the cockpit floor forward of the pilots' controls. In the EC-130, it is located on the cockpit floor forward of the pedestal and mounted to the pedestal. No additional access method is required.

b) Removal and Installation Methods

Caution: Use of power tools during removal or installation of panels and attaching hardware may damage nut plates or deform holes in composite doors, covers, panels, and fairings.

TITLE:
Air Conditioning System Installation Instructions For Continued
Airworthiness for Airbus Helicopters AS-350 B, C, D, D1, B1, B2, B3, BA &
EC-130 B4

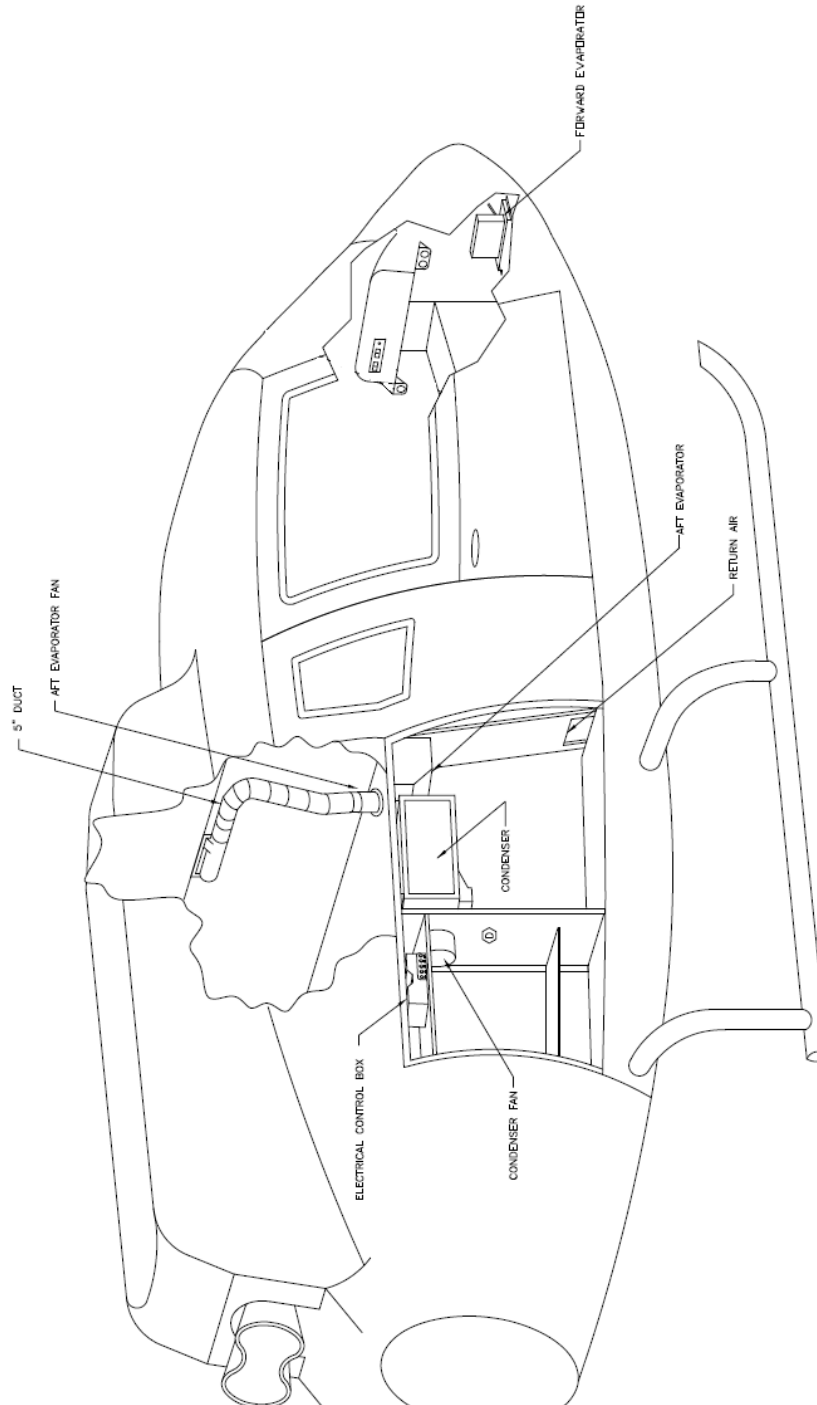

Figure 6-01: Side Mounted Condenser Configuration

TITLE:
Air Conditioning System Installation Instructions For Continued
Airworthiness for Airbus Helicopters AS-350 B, C, D, D1, B1, B2, B3, BA &
EC-130 B4

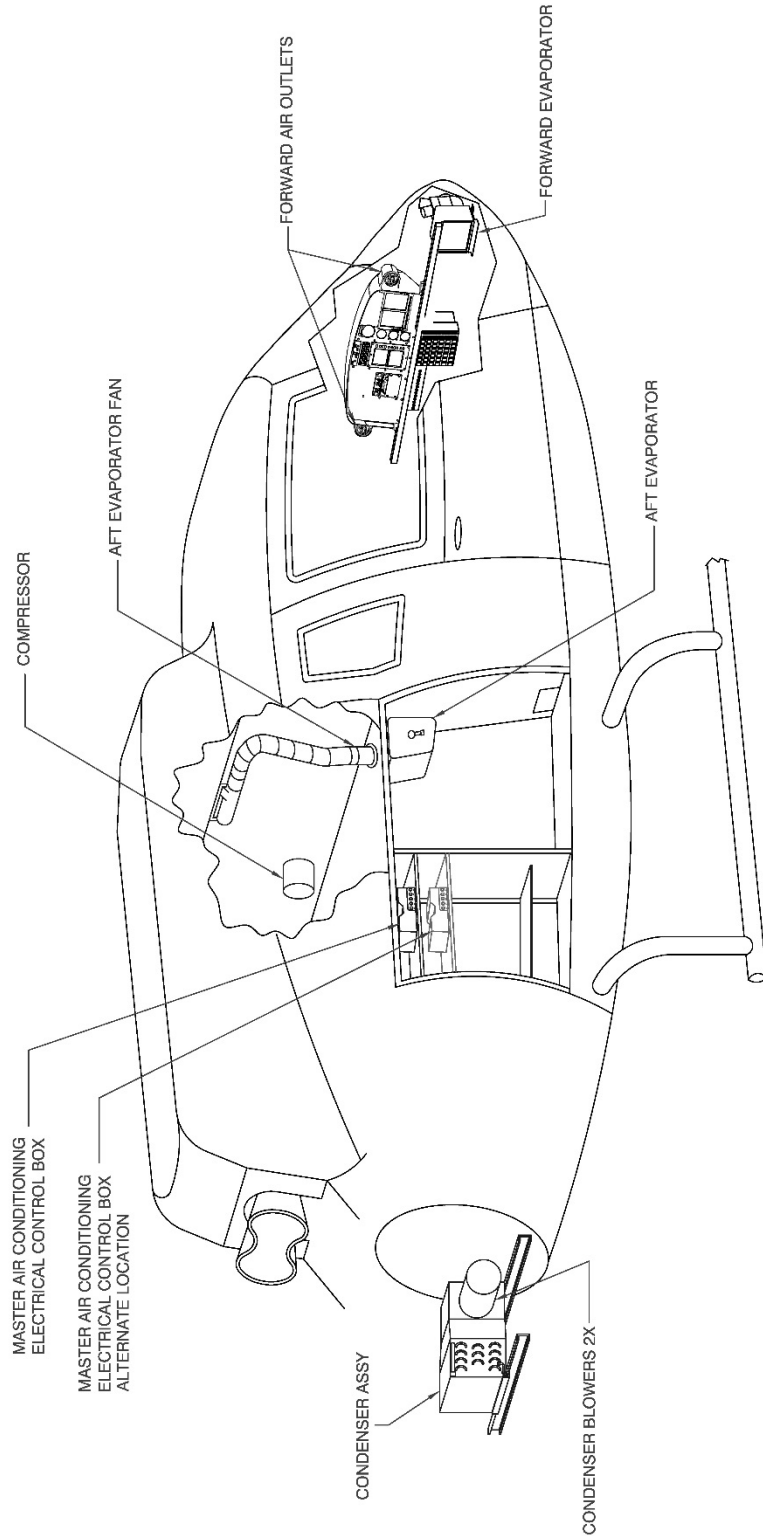
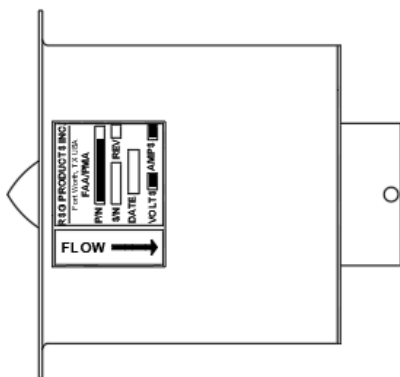

Figure 6-02: Aft Mounted Condenser Configuration

Chapter 11

Section 11-00-00 Placards and Markings

1. Placards and Decals



For PN: IFSS 050143



For PN: 550007-1

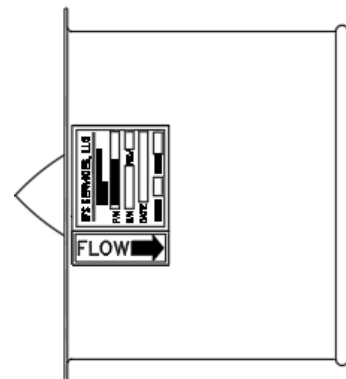

For PN: IFSS 050084

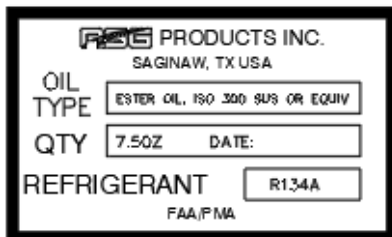

For PN: 590008 & 590008-1

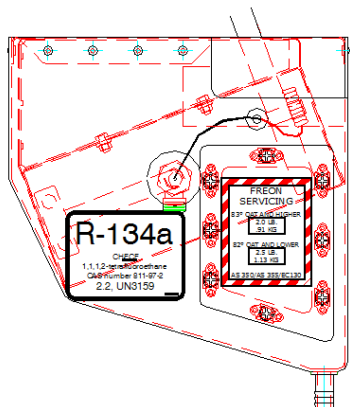

For PN: 560010-O-5 & 560016-O-1



For PN: 050145



DATE:
04/25/2025

DOC No.:
IFSE-0007

REV:
G

PAGE:
14 of 99

TITLE:
Air Conditioning System Installation Instructions For Continued
Airworthiness for Airbus Helicopters AS-350 B, C, D, D1, B1, B2, B3, BA &
EC-130 B4

Chapter 12

Section 12-00-00 Servicing Maintenance Practices

1. General

It is assumed in the following practices that the personnel engaged in Charging, Servicing, or Maintenance of the system will be either an experienced air conditioning mechanic under the supervision of a qualified A & P mechanic or an A & P mechanic possessing good air conditioning skills.

Section 12-10-00 Charging Practices

1. Reclaiming

- a) Connect the EPA approved recovery unit services hoses, which shall have shut-off valves to the aircraft air conditioning system service ports.
- b) Operate the recovery equipment as covered by the equipment manufacturers recommended procedure.
- c) Start the recovery process and remove the refrigerant from the aircraft air conditioning system. Operate the recovery unit until the aircraft system has been reduced from a pressure to a vacuum. With the recovery unit shut off for at least 5 minutes, determine that there is not refrigerant remaining in the aircraft air conditioning system. If the aircraft system has pressure, additional recover operation is required to remove the remaining refrigerant. Repeat the operation until the aircraft air conditioning system vacuum level remains stable for two minutes.
- d) Close the valves in the service lines and then remove the service lines from the aircraft system. Proceed with the repair/service. If the recovery equipment has automatic closing valves, be sure they are properly operating.

2. Charging

a) **Prior to Charging the System**

Prior to charging the system with R-134a, the evaporator fan/blower and condenser blower should be checked for operation and direction of airflow. This is most easily done by utilizing a GPU unit for electrical power. Since the compressor is belt driven only those maintenance and operational functions that are electrically powered may be checked either in the hanger or on the ramp without running the engine.

After the GPU is connected to the aircraft and the Aircraft Master Switch is "On", the air conditioning system may be turned "On". Place the rocker switch on the Master Air Conditioning Control Panel to "A/C". It does not cause the compressor to run or refrigerant to be pumped. All evaporator blowers and the forward evaporator fan should start immediately. The 7" condenser blower and clutch will not engage until after approximately 4 seconds after evaporator fan start.

NOTE: SYSTEM MUST HAVE MINIMUM 30 PSI CHARGE

Check airflow of each evaporator fan/blower. Determine that air is coming out of the cockpit and the cabin air outlets.



DATE:
04/25/2025

DOC No.:
IFSE-0007

REV:
G

PAGE:
16 of 99

TITLE:
Air Conditioning System Installation Instructions For Continued
Airworthiness for Airbus Helicopters AS-350 B, C, D, D1, B1, B2, B3, BA &
EC-130 B4

Check airflow into and out of condenser air openings.

b) **Charging the System**

*NOTE: All evaporators' fan/blower, condenser blowers, and controls are 28-volt DC.

DANGER: R-134a, particularly liquid R-134a, should never be allowed to come in contact with the eyes or skin. Under normal conditions, R-134a as a gas or vapor is an inert substance and non-poisonous. A flame-type leak detector should never be used because of the danger of fire or explosion around an aircraft. Several electronic leak detectors are available on the market.

Never heat a cylinder of R-134a to produce additional pressure or to squeeze that last bit of refrigerant from the cylinder. If the cylinder has become cooled to the point where additional refrigerant cannot be obtained from it, the only approved method is to place the entire cylinder in a container of warm water. **Do Not Exceed 120 Degrees Fahrenheit.**

Never attempt to repair a leak requiring brazing or soldering within the aircraft structure as fire or explosion can result. Remove the entire assembly from the aircraft to a safe location before attempting such a procedure.

CAUTION: Should R-134a come in contact with the eyes or skin, Do Not attempt first aid beyond the immediate washing of the eye or skin with clear water. A doctor should be contacted immediately for diagnosis and treatment even though the injury may be considered slight.

The refrigerant used in this system R-134a, and no other refrigerant is to be considered. Normal safety practices, such as wearing of gloves and the use of goggles, should be utilized as R-134a could freeze the eyeball instantly were it to come in contact with the eye. Also, frostbite could occur to areas of the skin if R-134a were allowed to come in contact.

Charging of the system is a simple procedure whether on initial or recharging after leakage repair. A set of refrigerant gauges with a minimum of three hoses should be connected to the high side and low side service ports provided.

Prior to charging each newly installed system with R-134a, **you will not need to charge compressor with oil since 7.5 ounces of ESTER oil has already been**

added. Do not add additional oil if replacing a compressor in an existing system.

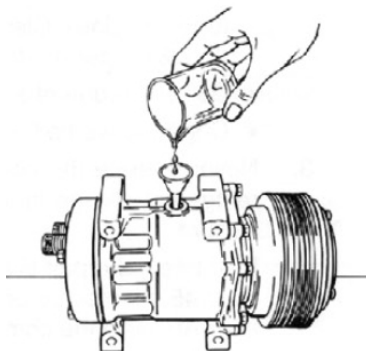

Figure 12 - 01: Adding Oil to the Compressor

c) **Initial Charging**

Tighten any leaking connections or make repairs as necessary to eliminate leaks. Shut off and disconnect hose from the refrigerant cylinder. Connect the hose to a regulator mounted on a cylinder of dry nitrogen. Purge the regulator to center manifold hose. **Close low side valve (left) at manifold. Failure to do so can cause pressure to flow to the low side (left) gauge. Failure of gauge can result.**

Pressurize system to 250-PSI minimum, 300-PSI maximum.

After the system has been rechecked with the leak detector and it is determined that no leaks exist, disconnect the charging hose from the manifold set to the cylinder of nitrogen. Open the valves allowing the R-134a and nitrogen within the system to be collected into an EPA approved recycling until (expelling of refrigerant is not allowed).

Connect a vacuum pump to the center manifold hose. Open both valves and evacuate the system for a minimum of twenty minutes. (**NOTE:** For each 1,000 foot rise in altitude above sea level, a decrease below 30" of vacuum of 1" per one thousand feet rise in altitude will occur).

d) **Adding R134-a Refrigerant**

Close both the manifold valves and connect the center charging hoses to a cylinder of R-134a. Open the valves of the cylinder. Purge the charging hose by loosening it at the charging manifold's center hose. **ONLY THE HIGH SIDE VALVE OF THE CHARGING MANIFOLD MAY NOW BE OPENED**



DATE:
04/25/2025

DOC No.:
IFSE-0007

REV:
G

PAGE:
18 of 99

TITLE:
Air Conditioning System Installation Instructions For Continued
Airworthiness for Airbus Helicopters AS-350 B, C, D, D1, B1, B2, B3, BA &
EC-130 B4

The combination of the vacuum still existing and the pressure in the R-134a cylinder transfers the R-134a from the cylinder into the system, **on the high side only**, without the compressor running. If a scale is available, the cylinder may be pre-weighted and **2.5 pounds of refrigerant R-134a added to the system**. No additional refrigerant should be added after the system is in operation. Close manifold.

The system is now ready for operation. **This must be performed on the flight line with the engine at 100%**. As soon as the "A/C" Master Control Switch is turned to "A/C" all 28 VDC evaporator fans will immediately begin operations.

If, after the system has been in the "A/C" mode for at least 2 minutes and cooling is not being accomplished, then check all circuit breakers.

Determine that 28 VDC power is available for control circuitry. Check operations of the relays and contacts

After the compressor has come on line, the entire system is operational with the manifold valve closed on the high side. The R-134a cylinder valve should be closed initially in order to get an accurate reading on the low side gauge of the "system pressure". The reading on the gauge should not be allowed to go below 10 PSI, as this will indicate that the low-pressure safety switch is possibly set too low. It will disconnect the electrical power to the compressor clutch if allowed to open. Open or close the cylinder valve as required to monitor the flow of R-134a from the cylinder into the low side of the system, if additional R-134a is needed. **Smoke test is no longer required for R-134a receiver/drier (without sight glass) like it was for R-12 receiver/drier (with sight glass).**

Charge system to 2.5 lbs. The optimum method of determining the correct charge using at least two digital thermometers and place them near the return air and the discharge air of each evaporator. R-134a can then be added or deleted, as required, until the highest T.D. is noted, per the paragraph below. At that time, the correct amount of refrigerant is installed.

A test sheet should be completed noting the average cabin temperature, the temperature on the return or entering air to all evaporators and the discharge air from the evaporators, at the nearest point. If a Temperature Differential (T.D.) of less than 20 degrees Fahrenheit with a humidity of 30% or less is recorded through the evaporators at sea level, the system should be considered as having possible defects, which will need investigation. At altitudes above sea level, less than 20 degrees Fahrenheit temperature difference may be recorded at humidity of 30% or less. This is due to less dense air moving more rapidly through the evaporators.



DATE:
04/25/2025

DOC No.:
IFSE-0007

REV:
G

PAGE:
19 of 99

TITLE:
Air Conditioning System Installation Instructions For Continued
Airworthiness for Airbus Helicopters AS-350 B, C, D, D1, B1, B2, B3, BA &
EC-130 B4

e) **Effect of Humidity on TD**

It should be noted that in measurements taken and entered on a test sheet that similar measurements made at a later date, when the humidity is considerably higher, would dramatically change the T.D.

The higher the humidity, as compared to a previous T.D. reading taken with a low humidity, will result in a lower T.D. The reason for this lower T.D. measurement is that when a test is performed at lower humidity, only "SENSIBLE HEAT" is being removed. With higher humidity, a different condition exists. It requires that "LATENT HEAT" containing moisture borne heat must first be removed prior to the removal of the sensible heat

If the system is found to be completely empty of R-134a, a set of charging gauges should be connected to both high and low side service ports and to a cylinder of R-134a. Purge the charging hoses from the cylinder to the service ports with R-134a vapor. Open both the low and high side charging valves and allow pressure from the cylinder to equalize through the system until at least 50 PSI is noted. Utilizing an electronic leak detector, check all fittings on the system to determine the point of leakage. Any fitting indicating an oily or dirty condition is a prime suspect.

f) **Recharging the System**

After the leaks have been found and corrected, pressurize the system with dry nitrogen. Re-check for leaks. Connect a vacuum pump to the system and evacuate the system for a minimum of 20 minutes from both the high and low sides. If the system has been allowed to become contaminated, then the receiver/drier is to be replaced.

It is always good air conditioning practice to replace the receiver/drier whenever it is suspected that moisture has contaminated the system.

The balance of the recharging procedure is exactly the same as pointed out previously under the **Charging Operation**. A judgment must be made as to the amount of oil, if any, lost at the point of leakage. Additional oil may be required to be added to the system. If the refrigerant has been expelled rapidly by the rupture of a line or similar situation, then two (2) ounces of refrigerant oil of the type previously specified should be applied to the system at this time and immediately prior to charging of the system with R-134a.

Section 12-20-00 Clutch Servicing Practices

1. General

These clutch servicing practices are applicable to all compressors that can be installed with the Air Conditioning System Installation.

a) Clutch Armature Assembly Removal

- (1) If armature dust cover is present, remove the 3 or 6 bolts holding it in place and remove cover. If auxiliary sheet metal pulley is present, remove the screws holding it in place. Then remove pulley.
- (2) Insert pins of armature plate spanner into threaded holes of armature assembly.
- (3) Hold armature assembly stationary while removing retaining nut with 3/4 in, 19 mm or 14 mm socket wrench as appropriate. (Ref. Figure 12-02)

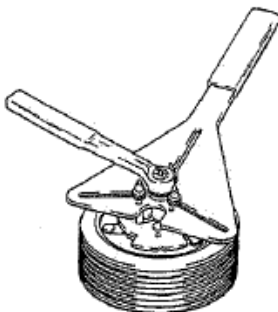
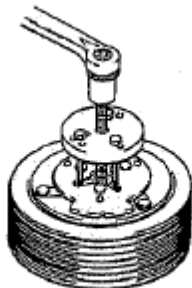

Figure 12 - 02

- (4) Remove armature assembly using puller. Thread 3 puller bolts into the threaded holes in the armature assembly. Turn center screw clockwise until armature assembly comes loose. (Ref. Figure 12-03)

Figure 12 - 03



- (5) If shims are above shaft key, the key and bearing dust cover (if present) must be removed before the shims can be removed.
- (6) Remove bearing dust cover (if present). Use caution to prevent distorting cover when removing it.
- (7) Remove shaft key by tapping loose with a flat blade screwdriver and hammer.
- (8) Remove shims. Use a pointed tool and a small screwdriver to prevent the shims from binding on the shaft.

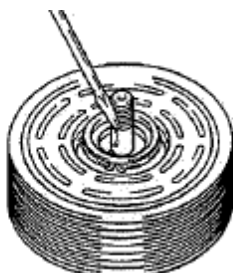

Figure 12 - 04

b) Rotor Assembly Removal

- (1) If bearing dust cover has not been removed, remove it now.
- (2) If internal snap ring for bearing is visible above the bearing, remove it with internal snap ring pliers.
- (3) Remove rotor snap ring.
- (4) Remove shaft key.
- (5) Remove rotor assembly: insert the lip of the jaws into the snap ring groove, place rotor puller shaft protector (puller set) over the exposed shaft, align thumb screws to puller jaws and finger tighten and turn puller center bolt

clockwise using a socket wrench until rotor pulley is free. (Ref. Figure 12-05)

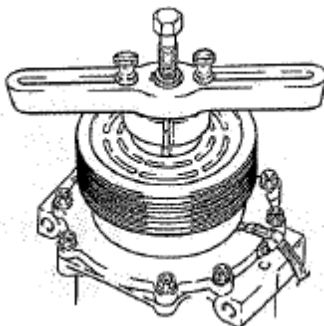

Figure 12 - 05

c) **Field Coil Assembly Removal**

- (1) Loosen lead wire clamp screw with #2 Phillips screwdriver until wire(s) can be slipped out from under clamp.
- (2) Undo any wire connections on the compressor which would prevent removal of the field coil assembly.
- (3) Remove snap ring.
- (4) Remove the field coil assembly. (Ref. Figure 12-06)

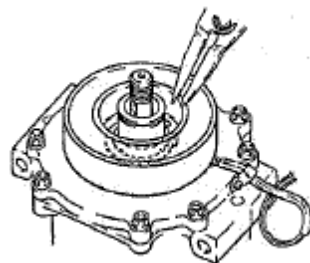

Figure 12 - 06

d) **Field Coil Assembly Installation**

- (1) Reverse the steps of the field coil assembly removal. Protrusion on underside of coil ring must match hole in front housing to prevent movement and correctly locate lead wire(s).

e) **Rotor Assembly Installation**

- (1) Place compressor on support stand, supported at rear end of compressor. If the compressor must be clamped in a vice, clamp only on the mounting ears, never on the body of the compressor.
- (2) Set rotor squarely over the front housing boss.
- (3) Place the rotor installer ring into the bearing bore. Ensure that the edge rests only on the inner race of the bearing, not on the seal, pulley, or outer race of the bearing.
- (4) Place the driver into the ring and drive the rotor down onto the front housing with a hammer or arbor press. Drive the rotor against the front housing step. A distinct change of sound can be heard when using a hammer to install the rotor. (Ref. figure 12-07).



Figure 12 - 07

- (5) Reinstall rotor bearing snap ring, if it has been removed, with internal snap ring pliers. (Ref. figure 12-08)



Figure 12 - 08

- (6) Reinstall rotor retaining snap ring with external snap ring pliers. If a bevel is present in the snap ring, it should be face up (away from the body of the compressor).
- (7) Reinstall rotor bearing dust cover (if present) by gently tapping it into place.

f) **Armature Assembly Installation**

- (1) Install shaft key with pliers. (Ref. figure 12-09)

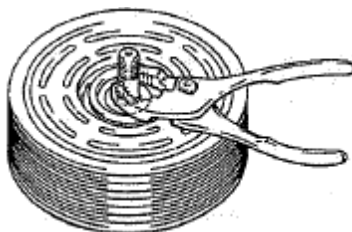

Figure 12 - 09

- (2) Install clutch shims. NOTE: Clutch air gap is determined by shim thickness. When installing a clutch on a used compressor, try the original shims first. When installing a clutch on a compressor that has not had a clutch installed before, first try 0.04 in, 0.02 in and 0.004 in (1.0, 0.5, 0.1 mm) shims.
- (3) Align keyway in armature assembly to shaft key. Using driver and a hammer or arbor press, drive the armature assembly down over the shaft until it bottoms on the shims. A distinct sound change will be noted if driving with a hammer. (Ref. figure 12-10)

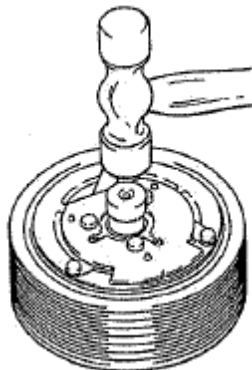

Figure 12 - 10

- (4) Replace retaining nut and torque to specification

1/2-20: 20-25 ft*lb (27-34 N*m)

M8: 11-15 ft*lb (15-21 N*m)

- (5) Check air gap with a feeler gauge. Specification is 0.011-0.019 in (0.3-0.5mm). If gap is not even around the clutch, gently tap down at the high spots. If the overall gap is out of spec, remove the armature assembly and change shims as necessary.

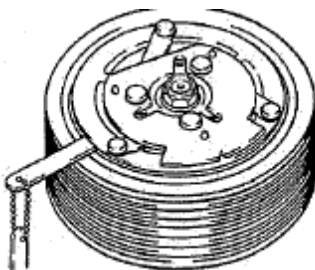

Figure 12 - 11

- (6) Replace armature dust cover (if used) and torque 3 or 6 bolts to specification below.

3-1/4-20 bolts: 2-4 ft*lb (2-5 N*m)

6-M5 bolts: 5-8 ft*lb (7-11 N*m)

NOTE: Over torque of dust cover bolts will cause air gap to become out of spec.



DATE:
04/25/2025

DOC No.:
IFSE-0007

REV:
G

PAGE:
26 of 99

TITLE:
Air Conditioning System Installation Instructions For Continued
Airworthiness for Airbus Helicopters AS-350 B, C, D, D1, B1, B2, B3, BA &
EC-130 B4

Section 12-30-00 System Leak Check

1. General

Identification and elimination of system fitting leaks is extremely important to the operation of this air conditioning system installation.

A system which contains a partial charge of refrigerant can be leak tested with the aid of an electronic leak detector and be recharged without evacuating the system.

A new or empty system can be pressurized with nitrogen 70-80 psi (5.1-5.6 kgcm) or R134a 50 psi to conduct a leak survey. Do not use compressed air, for it can introduce moisture into the system causing degradation to the operation of the system.

The preferred method is to use an electronic leak detector in conjunction with a small charge of R134a refrigerant. All checks done in this manner should be conducted with the air conditioner off. Since the refrigerant is heavier than air, leaks are most likely to be detected on the underside of the hoses and fittings. Refrigerants will collect in low areas and provide erroneous leak detection. A stream of compressed air from a nozzle may be useful in clearing the area just prior to conducting a leak test.

If the nitrogen method is used, it will be necessary to mix together a water and mild soap solution. Each fitting or suspected leak area should be brushed with this soap solution and watched for evidence of bubbles formed by the escaping nitrogen.

If a leak is detected at an O-ring fitting, check to ensure proper torque has been applied to the fitting. If the system continues to leak, evacuate the system of refrigerant and install a new O-ring. NOTE: be sure that the O-ring is lubricated with refrigerant oil prior to its installation.

A small amount of leakage (approximately one ounce per year) past the compressor shaft seal is normal. Most leak detectors are sensitive enough to show a leak a magnitude.

Section 12-40-00 Fitting Torque Procedures

1. Fitting Torque Procedures and Torque Values

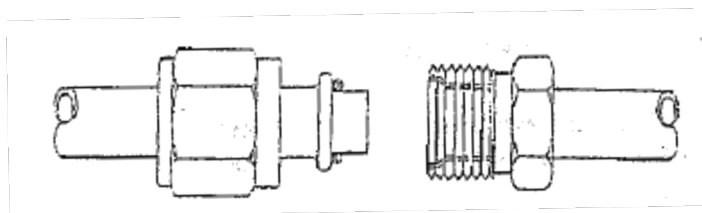

Figure 12 – 12: Insert O-Ring Fittings

- (1) Confirm there is no damage on fittings.
- (2) Apply a thin coating of refrigerant oil to O-ring and female side of fitting.
- (3) Slide B-nut back away from the end of the tube so the O-ring can be seen as the fitting is being slide together. Be careful not to pinch the O-ring during assembly.
- (4) Engage the male end into the female fitting being careful to maintain alignment.
- (5) The male flange should seat fully against the female fitting without the O-ring being pinched.
- (6) It is important to hold the fitting together while sliding the B-nut forward and engaging the threads. Tighten the B-nut by hand and torque per table 12-01. **DO NOT OVER TORQUE.**

Table 12-01 Fitting Torque Values

Fitting #	Torque Value in/lbs (Nm)
#6	30-35 (3.4-4.0)
#8	40-45 (4.6-5.1)
#10	50-55 (5.7-6.3)



DATE:
04/25/2025

DOC No.:
IFSE-0007

REV:
G

PAGE:
28 of 99

TITLE:
Air Conditioning System Installation Instructions For Continued
Airworthiness for Airbus Helicopters AS-350 B, C, D, D1, B1, B2, B3, BA &
EC-130 B4

Section 12-50-00 Normal Operation Functional Test

- a. With the aircraft engine operating, electrical system on and functioning normally, move the air conditioner control switch to the "FAN" position.
- b. Move the cockpit fan switch from "LOW" to "HIGH" speed and ensure that air output is present in all the forward air outlets. Repeat the test using the aft cabin fan speed selector switch for the aft cabin air outlets.
- c. Reposition the air conditioner control switch to the "A/C" position and repeat Step 2 above. Cool air should be supplied to the cockpit and cabin vents after a time delay of 15 seconds.
- d. Turn air conditioner switch to "OFF" or the center position. Entire system should shut down.

Section 12-60-00 Belt Tension Procedure

With the compressor drive belt on the drive pulley and the compressor clutch pulley. Tighten bolts at the adjustment arm assuring the belt proper amount of tension. Tighten the lower forward mounting bolt. Use a pull scale to measure the tension. (Ref. figure 12-13). Recommended belt tension values if using a grooved belt is 30 lbs and if using a flat belt is 50 lbs.

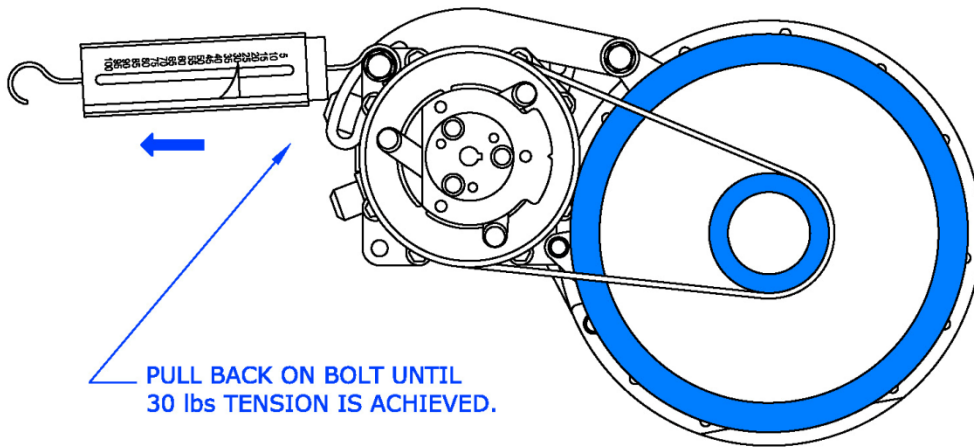

060005 GROOVED BELT

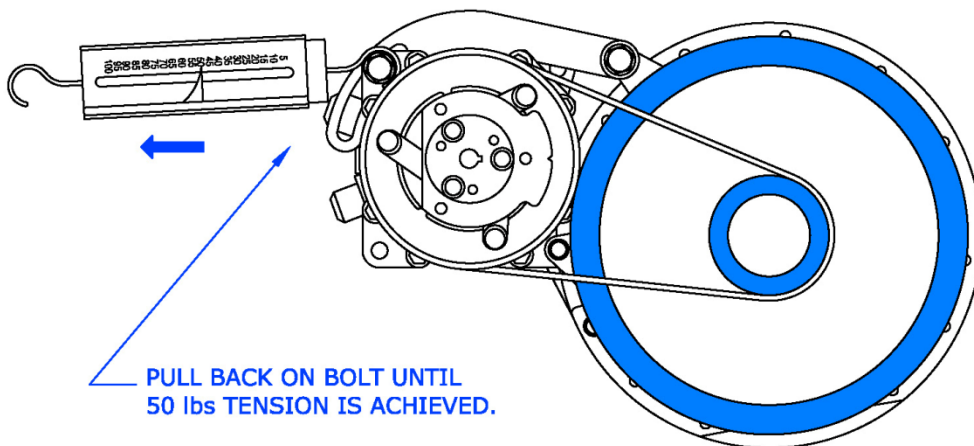

060018-1 FLAT BELT

Figure 12 – 13



DATE:
04/25/2025

DOC No.:
IFSE-0007

REV:
G

PAGE:
30 of 99

TITLE:
Air Conditioning System Installation Instructions For Continued
Airworthiness for Airbus Helicopters AS-350 B, C, D, D1, B1, B2, B3, BA &
EC-130 B4

Section 12-70-00 Drive Belt Change Procedure

- a. Access the compressor installation (ref. Section 6-00-00 Dimensions and Access). For compressor information reference Section 21-00-00 Air Conditioning.
- b. Place a support on the transmission deck to support the engine drive while the shaft is disconnected for belt installation.
- c. Remove the cotter pins from the four pins holding the “Gimble Ring” at the Thomas coupling.
- d. Slide the “Gimble Ring” aft to gain access to the Thomas coupling.
- e. Remove the 6 bolts and Thomas coupling connecting the drive shaft and shift slightly aft.
- f. Install two (2) Compressor Drive belts.
- g. Reassemble the Thomas coupling.
- h. Secure 1 belt to the outside of the drive shaft cover for a spare and slip one through the housing and over the drive pulley.
- i. Install the “Gimble Ring” pins and cotter pins. Remove supports.
- j. Install the compressor drive belt on the drive pulley and the compressor clutch pulley. Tighten bolts at the adjustment arm assuring the belt proper amount of tension. (Ref. Section 12-60-00 Belt Tension Procedure). Tighten the lower forward mounting bolt.



DATE:
04/25/2025

DOC No.:
IFSE-0007

REV:
G

PAGE:
31 of 99

TITLE:
Air Conditioning System Installation Instructions For Continued
Airworthiness for Airbus Helicopters AS-350 B, C, D, D1, B1, B2, B3, BA &
EC-130 B4

Chapter 20

Section 20-00-00 Standard Practices

This chapter contains maintenance information and procedures that are common standard practices. Information contained in this chapter is standard torque charts and application procedures, corrosion prevention, painting, mechanical fastener sealing, and dye penetrant inspection techniques.

Section 20-10-00 Torques Maintenance Practices

1. Torque Wrenches

a) Torque Wrench Accuracy

Torque wrenches must be of good quality and calibrated at least once a year. Any torque wrench that has been dropped or abused should be calibrated to ensure continued accuracy.

b) Application of Torque Wrench Loads

- (1) Be sure the bolt and nut and the surface they bear on are clean and dry, unless otherwise specified by the manufacturer.
- (2) Run the nut down to near contact with the washer or bearing surface and check the friction drag torque required to turn the nut. Add the friction drag torque to the desired torque to arrive at the "final torque" to be registered on the torque wrench indicator.
- (3) Whenever possible, apply the torque to the nut instead of the bolt. This will reduce rotation of the bolt in the hole and reduce wear.
- (4) Apply a smooth even pull when applying torque pressure.
- (5) If special adapters are used which will change the effective length of the torque wrench, the final torque indication or wrench setting must be adjusted accordingly. To determine the torque wrench setting or indication with adapter installed reference Figure 20-01.

TITLE:
Air Conditioning System Installation Instructions For Continued Airworthiness for Airbus Helicopters AS-350 B, C, D, D1, B1, B2, B3, BA & EC-130 B4

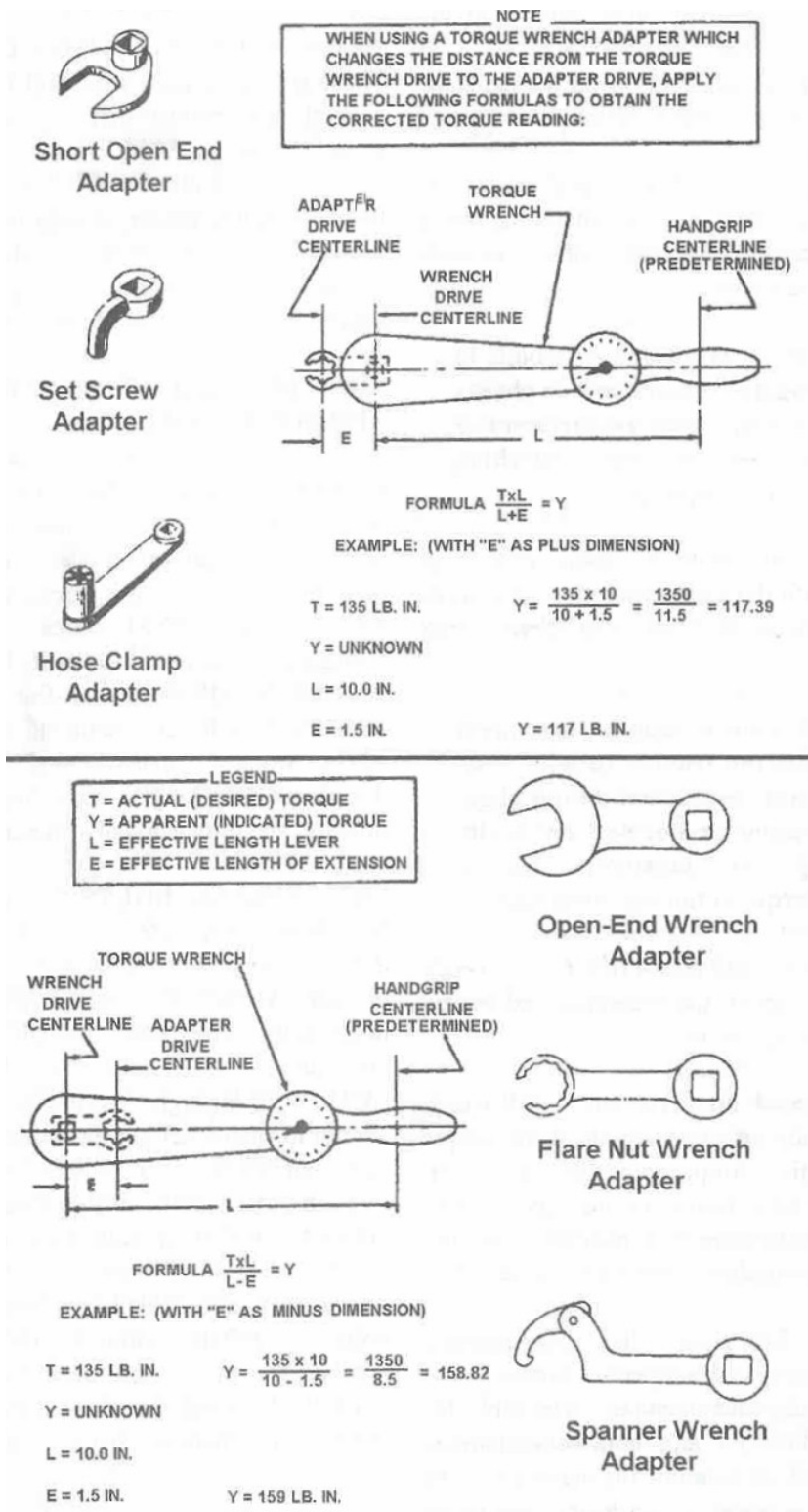

Figure 20 - 1: Torque Wrenches and Adapters

2. Torque Values

Warning: Do not exceed maximum allowable torque value. Overstressing of fastener may result.

Standard hardware torque values are given in the following **Table 20 - 1** through **Table 20 - 3**. **Table 20 - 1** gives recommended torque values for fine thread fasteners, shear and tension applications. **Table 20 - 2** gives recommended torque values for coarse thread fasteners, shear and tension applications. **Table 20 - 3** gives recommended torque values for Phillips-head screws.

Table 20 - 1: Recommended Torque Values for Fine-Thread Fasteners

Thread Size Fractional (decimal)	Shear		Tension	
	Recommended in-lb (N-m)	Maximum in-lb (N-m)	Recommended in-lb (N-m)	Maximum in-lb (N-m)
8-36 (0.1640-36)	7-9 (0.79-1.02)	12 (1.36)	12-15 (1.36-1.69)	20 (2.26)
10-32 (0.1900-32)	12-15 (1.36-1.69)	25 (2.82)	20-25 (2.25-2.82)	40 (4.51)
1/4-28 (0.2500-28)	30-40 (3.38-4.51)	60 (6.77)	50-70 (5.64-7.90)	100 (11.29)
5/16-24 (0.3125-24)	60-85 (6.77-9.60)	140 (15.81)	100-140 (11.29-15.81)	225 (25.41)
3/8-24 (0.3750-24)	95-110 (10.73-12.42)	240 (27.11)	160-190 (18.07-21.46)	390 (44.05)
7/16-20 (0.4375-20)	270-300 (30.49-33.88)	500 (56.48)	450-500 (50.83-56.48)	840 (94.88)
1/2-20 (0.5000-20)	290-410 (32.75-46.31)	660 (74.55)	480-690 (54.22-77.94)	1,100 (124.25)
9/16-18 (0.5625-18)	480-600 (54.22-67.77)	960 (108.44)	800-1,000 (90.36-112.96)	1,600 (180.73)
5/8-18 (0.6250-18)	660-780 (74.55-88.10)	1,400 (158.14)	1,100-1,300 (124.25-146.84)	2,400 (271.10)
3/4-16 (0.7500-16)	1,300-1,500 (146.84-169.44)	3,000 (338.88)	2,300-2,500 (259.80-282.40)	5,000 (564.80)
7/8-14 (0.8750-14)	1,500-1,800 (169.44-203.32)	4,200 (474.43)	2,500-3,000 (282.40-338.88)	7,000 (790.72)
1-12 (1.0000-12)	2,200-3,300 (248.51-372.76)	6,000 (677.76)	3,700-5,500 (417.95-621.28)	10,000 (1129.6)
1-1/8-12 (1.1250-12)	3,000-4,200 (338.88-474.43)	9,000 (1016.6)	5,000-7,000 (564.80-790.72)	15,000 (1694.4)
1-1/4-12 (1.2500-12)	5,400-6,600 (609.98-745.53)	15,000 (1694.4)	9,000-11,000 (1016.6-1242.6)	25,000 (2824.0)



DATE:
04/25/2025

DOC No.:
IFSE-0007

REV:
G

PAGE:
35 of 99

TITLE:
Air Conditioning System Installation Instructions For Continued
Airworthiness for Airbus Helicopters AS-350 B, C, D, D1, B1, B2, B3, BA &
EC-130 B4

Table 20 - 2: Recommended Torque Values for Coarse-Thread Fasteners

Thread Size Fractional (decimal)	Shear		Tension	
	Recommended in-lb (N-m)	Maximum in-lb (N-m)	Recommended in-lb (N-m)	Maximum in-lb (N-m)
8-32 (0.1640-32)	7-9 (0.79-1.02)	12 (1.36)	12-15 (1.36-1.69)	20 (2.26)
10-24 (0.1900-24)	12-15 (1.36-1.69)	21 (2.37)	20-25 (2.25-2.82)	35 (3.95)
1/4-20 (0.2500-20)	25-30 (2.82-3.38)	45 (5.08)	40-50 (4.51-5.64)	75 (8.47)
5/16-18 (0.3125-18)	48-55 (5.42-6.21)	100 (11.29)	80-90 (9.03-10.16)	160 (18.07)
3/8-16 (0.3750-16)	95-100 (10.73-11.29)	170 (19.20)	160-185 (18.07-20.89)	275 (31.06)
7/16-14 (0.4375-14)	140-155 (15.81-17.50)	280 (31.62)	235-255 (26.54-28.8)	475 (53.65)
1/2-13 (0.5000-13)	240-290 (27.11-32.75)	520 (58.73)	400-480 (45.18-54.22)	880 (99.40)
9/16-12 (0.5625-12)	300-420 (33.88-47.44)	650 (73.42)	500-700 (56.48-79.07)	1,100 (124.25)
5/8-11 (0.6250-11)	420-540 (47.44-60.99)	900 (101.66)	700-900 (79.07-101.66)	1,500 (169.44)
3/4-10 (0.7500-10)	700-950 (79.07-107.31)	1,500 (169.44)	1,150-1,600 (129.90-180.73)	2,500 (282.40)
7/8-9 (0.8750-9)	1,300-1,800 (146.84-203.32)	2,700 (474.43)	2,200-3,000 (248.51-338.88)	4,600 (519.61)
1-8 (1.0000-8)	2,200-3,000 (248.51-338.88)	4,500 (508.32)	3,700-5,000 (417.95-564.80)	7,600 (858.49)
1-1/8-8 (1.1250-8)	3,300-4,000 (372.76-451.84)	7,200 (813.31)	5,500-6,500 (621.28-734.24)	12,000 (1355.5)
1-1/4-8 (1.2500-8)	4,000-5,000 (451.84-564.80)	10,000 (1129.6)	6,500-8,000 (734.24-903.68)	16,000 (1807.4 N m)



DATE:
04/25/2025

DOC No.:
IFSE-0007

REV:
G

PAGE:
36 of 99

TITLE:
Air Conditioning System Installation Instructions For Continued
Airworthiness for Airbus Helicopters AS-350 B, C, D, D1, B1, B2, B3, BA &
EC-130 B4

Table 20 - 3: Recommended Torque Values for Phillips-Head Fasteners

Thread Size Fractional (decimal)	Recommended in-lb (N-m)	Maximum in-lb (N-m)
8-32 (0.1640-32)	12-15 (1.36-1.69)	23 (2.59)
10-32 (0.1900-32)	20-25 (2.25-2.82)	35 (3.95)
1/4-28 (0.2500-28)	60-70 (6.77-7.90)	90 (10.16)
5/16-24 (0.3125-24)	110-125 (12.42-14.12)	150 (16.94)
3/8-24 (0.3750-24)	150-175 (16.94-19.76)	225 (25.41)
7/16-20 (0.4375-20)	230-280 (25.98-31.62)	450 (50.83)
1/2-20 (0.5000-20)	550-650 (62.12-73.42)	850 (96.01)
9/16-18 (0.5625-18)	750-900 (84.72-101.66)	1,200 (135.55)
5/8-18 (0.6250-18)	1,100-1,300 (124.25-146.84)	1,600 (180.73)



DATE:
04/25/2025

DOC No.:
IFSE-0007

REV:
G

PAGE:
37 of 99

TITLE:
Air Conditioning System Installation Instructions For Continued
Airworthiness for Airbus Helicopters AS-350 B, C, D, D1, B1, B2, B3, BA &
EC-130 B4

Section 20-30-00 Painting Maintenance Practices

The following procedures should be used to touch-up paint flaking, scratches, nicks, and gouges in system components.

Warning: Cleaning solvents and epoxy primer are flammable. Cleaning solvents, epoxy primer, and alodine can cause burns and irritation when skin is contacted. Vapors are harmful and caustic to eyes; goggles must be worn for eye protection. Cleaning solvents and alodine are poisonous. Vapors are harmful to life or health; work should be performed with proper ventilation and / or respirators should be worn while working with cleaning solvents, epoxy primer and alodine.

1. Paint Touch-Up of Small Areas

Use the following procedures to touch-up paint of small sanded areas and nicks, scratches, gouges, etc., that do not go through paint and primer to bare metal.

- a. Wipe surface clean with trichloroethane, MIL-T-81533, or equivalent cleaning solvent, and wipe dry immediately.
- b. Apply coat of epoxy polyamide primer, MIL-P-23377F or equivalent, to match original. Feather primer coating onto surrounding color coat. Allow primer to air dry for 30 minutes.
- c. Apply topcoat to match original finish.

Section 20-40-00 Corrosion Control Maintenance Practices

1. Corrosion Control

The system components are fabricated primarily of steel and aluminum, and should be inspected regularly for any signs of corrosion. The following procedures should be used for removing corrosion and treating affected areas.

2. Corrosion Removal

Remove corrosion by either chemical or mechanical means.

a) Paint Removal, Chemical

Caution: Do not use chemical paint stripper on composite materials. Chemical paint strippers can cause composite components to de-bond and / or lose adhesion of the epoxy matrix.

- (1) Mask all non-metallic surfaces in area to be stripped as well as areas where solution may get entrapped.

Warning: Paint stripper can cause burns and irritation when it contacts skin; proper gloves should be worn. Vapors are harmful and caustic to eyes; goggles must be worn for eye protection. Paint stripper is poisonous. Vapors are harmful to life or health; work should be performed with proper ventilation and / or respirators should be worn while working with paint stripper.

- (2) Using a fiber brush, apply sufficient paint stripper (Turco 5873) to cover area of removal.

Note: If paint stripper evaporates quickly or works slowly, cover area with plastic sheet.

- (3) Allow paint remover to remain on surface for a time sufficient to cause wrinkling and lifting of paint (about 10-30 minutes).
- (4) Using non-metallic scraper or abrasive pads (3M Scotchbrite 63) scrub area to further loosen paint.
- (5) Reapply paint stripper (Turco 5873) as necessary in areas where paint remains tightly adherent.



DATE:
04/25/2025

DOC No.:
IFSE-0007

REV:
G

PAGE:
39 of 99

TITLE:
Air Conditioning System Installation Instructions For Continued
Airworthiness for Airbus Helicopters AS-350 B, C, D, D1, B1, B2, B3, BA &
EC-130 B4

(6) Wash and scrub surface with demineralized water and alkaline cleaner to neutralize paint stripper.

(7) Remove masking materials and any residual paint or stripper

(8) Rinse with demineralized water.

b) Paint Removal, Mechanical

Caution: Do not sand into or expose composite fibers. Do not remove more material than necessary. Do not use aluminum oxide abrasive materials on epoxy/graphite materials.

Use abrasive flap wheel, abrasive disk, abrasive paper, or plastic media blast to remove paint.

c) Corrosion Removal

Note: Aircraft shall be electrically grounded during corrosion removal operations. When removing exterior corrosion from electronic boxes, the unit case shall be electrically grounded during the complete operation.

(1) Corrosion shall be removed by the mildest method possible.

(a) Hand scrub with dry non-metallic brush/pad (3M pad).

(b) Use abrasive cloth (Aluminum oxide 240 grit). Caution: Do not use on epoxy/graphite materials.

(c) Use 320-grit sandpaper.

(d) Glass bead blast.

(e) Use 240-grit abrasive wheel.

Note: On high-strength steel, do not use power tools other than a flap brush or mandrel with abrasive material; overheating and notching may occur.

(2) Ensure all active corrosion and corrosion products have been removed.

(3) Using 320-grit sandpaper, blend edges of paint (if applicable) surrounding repair area to create a smooth transition. Vacuum the area thoroughly to remove all contaminants.

(4) Apply aluminum surface treatment if applicable. (Ref. Section 4 of 20-40-00, Aluminum Alloy Surface Touch-Up Treatment).

(5) Touch-up primer and paint to match original.

3. Mechanical Defects (Nicks, Scratches, Gouges, Etc.)

- a) Section 20-30-00 Painting Maintenance Practices).
- b) If damage is through the paint surface, prepare area for paint touch-up using the following methods.

Note: On high-strength steel, do not use power tools other than a flap brush or mandrel with abrasive material; overheating and notching may occur.

- (1) Remove defect using flap wheel, abrasive disk, abrasive paper, or plastic media blast.
- (2) Using 320-grit sandpaper, blend edges of paint surrounding repair area to create a smooth transition.
- (3) Apply aluminum surface treatment if applicable. (Ref. Section 4 of 20-40-00, Aluminum Alloy Surface Touch-Up Treatment).
- (4) Touch-up primer and paint to match original.

4. Aluminum Alloy Surface Touch-Up Treatment

Note: If there is any question as to whether or not the protective coating is removed, surface treatment shall be applied.

Warning: Alodine and solvents can cause burns and irritation when it contacts skin; proper gloves should be worn. Vapors are harmful and caustic to eyes; goggles must be worn for eye protection. Alodine is poisonous. Vapors are harmful to life or health; work should be performed with proper ventilation and / or respirators should be worn while working with solvents and alodine. Solvent cleaners are flammable.

- a) Scuff surface using 3M Scotchbrite 63 cellulose/nylon scouring pad.
- b) Wipe exposed surface with isopropyl alcohol or aliphatic naphtha. Allow area to air dry for 10 minutes. Do not touch or otherwise contaminate surface after solvent wipe.



DATE:
04/25/2025

DOC No.:
IFSE-0007

REV:
G

PAGE:
41 of 99

TITLE:
Air Conditioning System Installation Instructions For Continued
Airworthiness for Airbus Helicopters AS-350 B, C, D, D1, B1, B2, B3, BA &
EC-130 B4

- c) Apply Alodine 1200 or equivalent with cotton swab, non-metallic brush, or by dipping. Maintain moist surface for 1-3 minutes with repeated application. Surface will become amber or brown in color.
- d) Irrigate surface with demineralized or distilled water to remove surface treatment chemical. Allow to air dry for approximately 1 hour.
- e) If there is any surface without color change, repeat procedure.
- f) Apply paint touch-up as required (Ref Section 20-30-00 Painting Maintenance Practices).

Section 20-50-00 Mechanical Fastener Sealing Methods

Remove existing cracked, chipped or broken existing sealing compound and thoroughly clean with solvent. Reseal using MIL-S-8802, sealing compound, mixing per manufacturer's instructions.

Seal mechanical fasteners as shown:

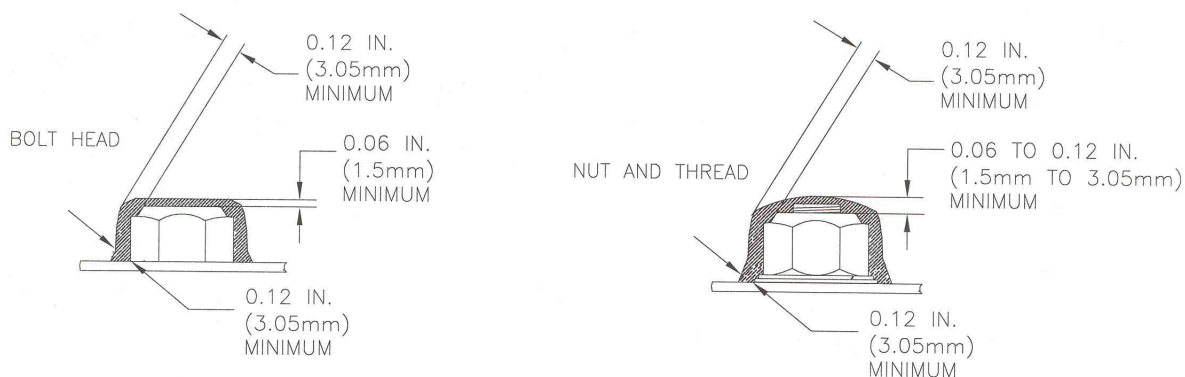

Figure 20 - 02: Mechanical Fastener Sealing

Section 20-90-00 Dye-Penetrant Inspection Methods

Warning: solvents can cause burns and irritation when it contacts skin; proper gloves should be worn. Vapors are harmful and caustic to eyes; goggles must be worn for eye protection. Vapors are harmful to life or health; work should be performed with proper ventilation and / or respirators should be worn while working with solvents. Solvent cleaners are flammable.

Use the following steps to perform dye-penetrant inspection:

1. Using cleaning solvent trichloroethane, MIL-T-81533, clean area to be inspected.
Note: Parts to be inspected must be dry and heated to at least 70° F (21.1° C), but not over 130° F (54.4° C).
Note: Manufacturer's instructions on Dye-Penetrant Kit take precedence over the following instructions.
2. Apply penetrant from dye-penetrant kit (ASTM E1417) by brushing, spraying, or by dipping. Allow to stand for a minimum of 2 minutes.
3. Remove excess penetrant with remover (available with dye-penetrant kit), or by cleaning with plain water. Allow part to dry.
4. Apply a light, even layer of developer from dye-penetrant kit by brushing, spraying, or by dipping. When dipping, avoid excess quantity.
5. Penetrant which has penetrated into cracks (or other openings) in the surface of the part will be drawn out by the developer, resulting in a bright red indication.
6. If part is serviceable or repairable, clean part free of penetrant and developer with trichloroethane (MIL-T-81533) cleaning solvent.

Chapter 21

Section 21-00-00 Air Conditioning

1. Description and Operation

The Air Conditioning System Installation consists of a belt driven vapor cycle air-conditioning system using R-134a as the refrigerant. The air conditioning system provides for cabin comfort during all operations, both in the ground and in flight. During ground operations when the engines are running, cooling may be provided.

This system consists of 4 major components:

- **Condenser-** The condenser is located in one of two positions depending on kit part number (Ref. table 21.1). The aft mounted condenser (Ref. figure 21-01) is mounted in the tail boom mounted 5 in. above the baggage floor. The side mounted condenser is located in the right baggage compartment (Ref. figure 21-02). The EC-130 condenser is only located in the aft mounted configuration. The aft mounted condenser assembly has two blower motors, whereas the side mounted condenser assembly only has one blower motor.
- **Compressor-** The compressor is located aft and to the left side on main transmission deck. The belt is secured to the outside of the drive shaft, in all configurations. If designated by the kit part number (Ref. tables 21-01 & 21-02), either a smooth pulley compressor or a grooved double V-belt pulley compressor is installed.
- **Aft Evaporator-** The aft evaporator is located on the right-hand upper transmission deck in all configurations.
- **Forward Evaporator-** In the AS-350 series, the forward evaporator is located on the cockpit floor forward of the pilots' controls. In the EC-130 kits, it is located forward of the pedestal and mounted to the pedestal.

Controls for the air conditioning system are located around or in the instrument panel, the specific location depending on the Kit number part as described in tables 21-01 and 21-02. All kits contain a Master Control Selector, which consists of a rocker type switch labeled, "A/C", "OFF" and "FAN." Selecting the "A/C" turns on the system's dual evaporator fans, compressor and condenser blower. The second rocker switch, also included with every kit, is for "HIGH," "MED" and "LOW" evaporator fan speed selection for the forward cockpit. An additional 2 position switch for the aft evaporator fan speed "HI/LOW" is present depending on the kit part numbers and the switch is located per that kit.



DATE:
04/25/2025

DOC No.:
IFSE-0007

REV:
G

PAGE:
45 of 99

TITLE:
Air Conditioning System Installation Instructions For Continued
Airworthiness for Airbus Helicopters AS-350 B, C, D, D1, B1, B2, B3, BA &
EC-130 B4

Table 21-1 Air Condition System Installation Kit Part Number Description AS-350 Series

AS-350 Series	
BASE KIT NUMBERS:	
350-00-011-HP	AEC Basic Configuration Side Mounted Condenser (Ref Figure 21-01)
350-00-031-HP	AEC Basic Configuration Aft Mounted Condenser (Ref Figure 21-02)

Table 21-2 Air Condition System Installation Kit Part Number Description EC-130 Series

EC-130B4	
BASE KIT NUMBER:	
130-00-031-HP*	Aft Mounted Condenser (Ref Figure 21-02)
CUSTOM CONFIGURATIONS:	
Corporate Configuration (Ref Figure 21-05)	

TITLE:
Air Conditioning System Installation Instructions For Continued
Airworthiness for Airbus Helicopters AS-350 B, C, D, D1, B1, B2, B3, BA &
EC-130 B4

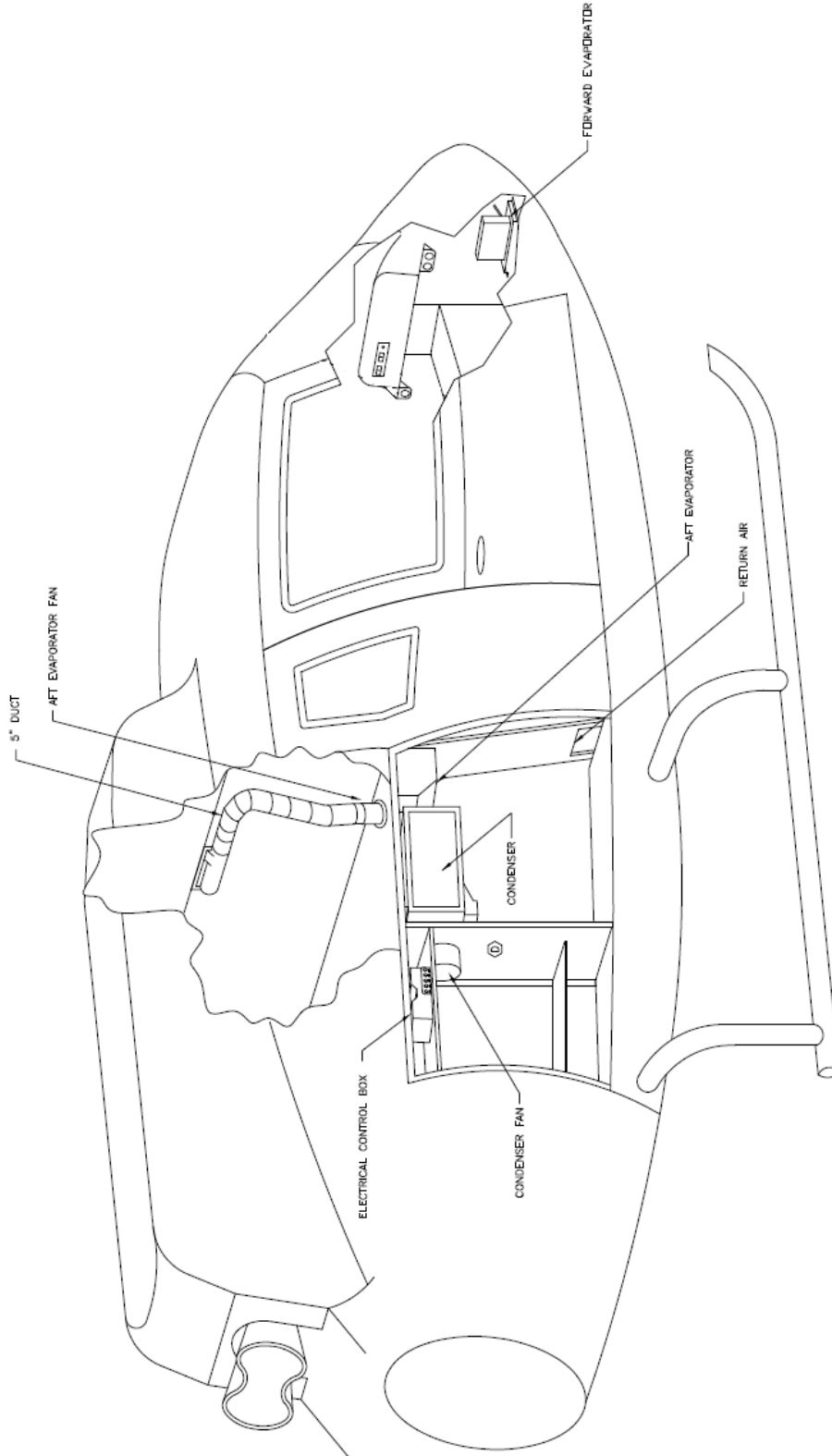

Figure 21-01: Equipment Locations for Air Conditioning System
with the -011 Configuration (Side Mounted Condenser)

TITLE:
Air Conditioning System Installation Instructions For Continued
Airworthiness for Airbus Helicopters AS-350 B, C, D, D1, B1, B2, B3, BA &
EC-130 B4

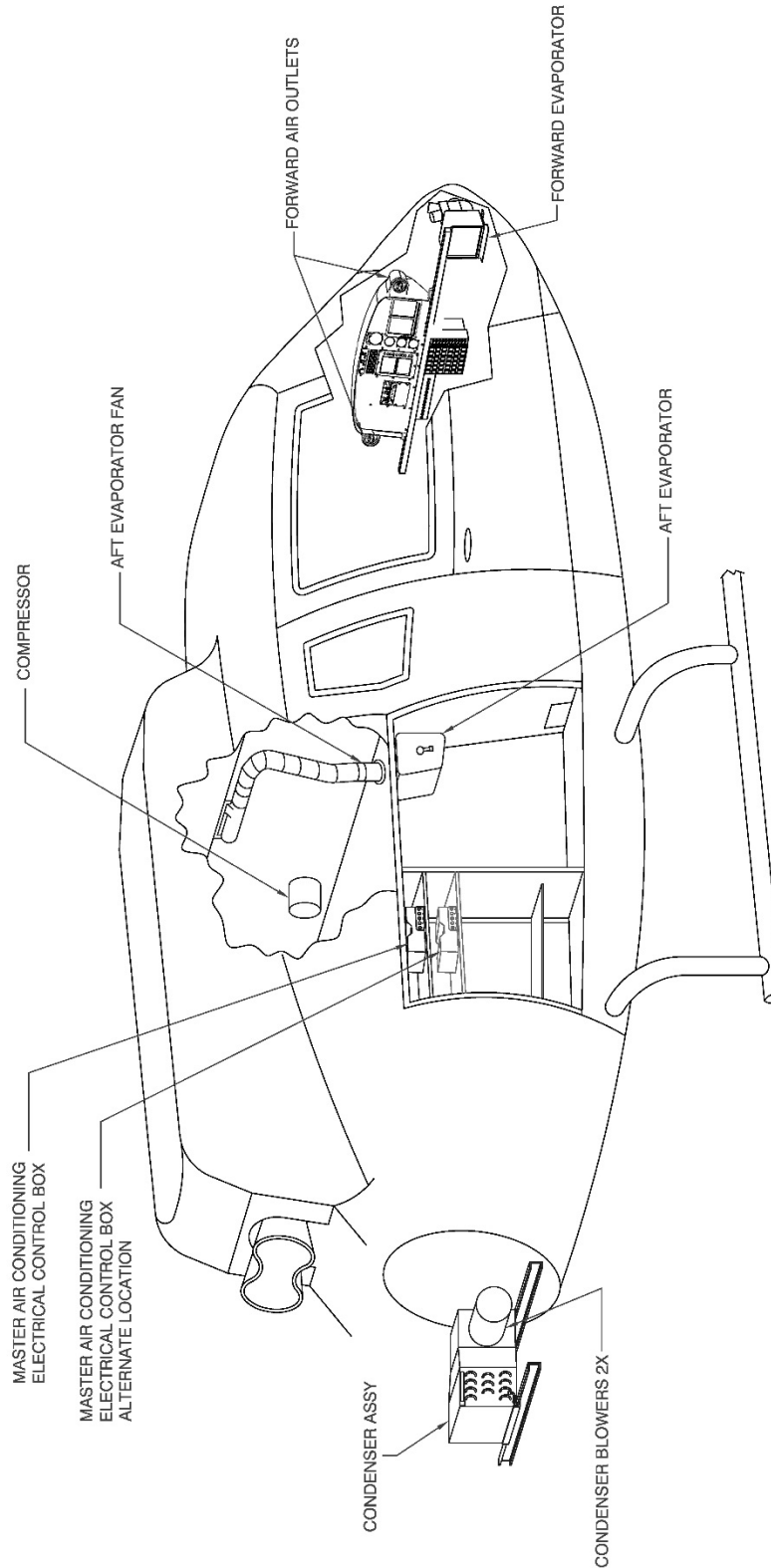
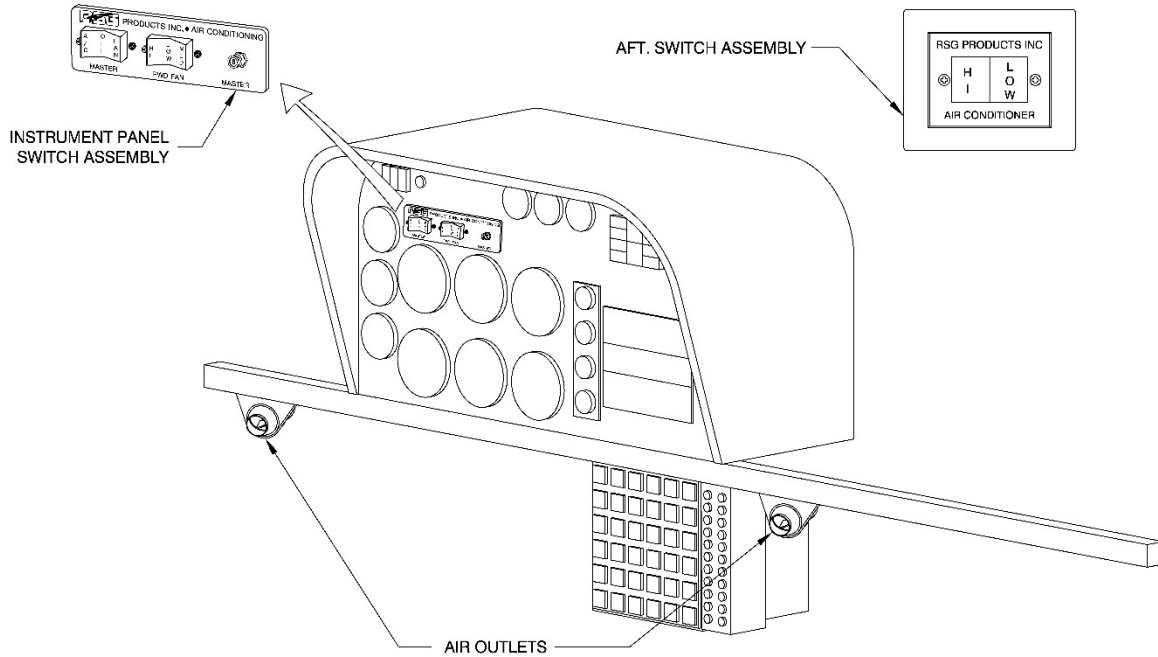
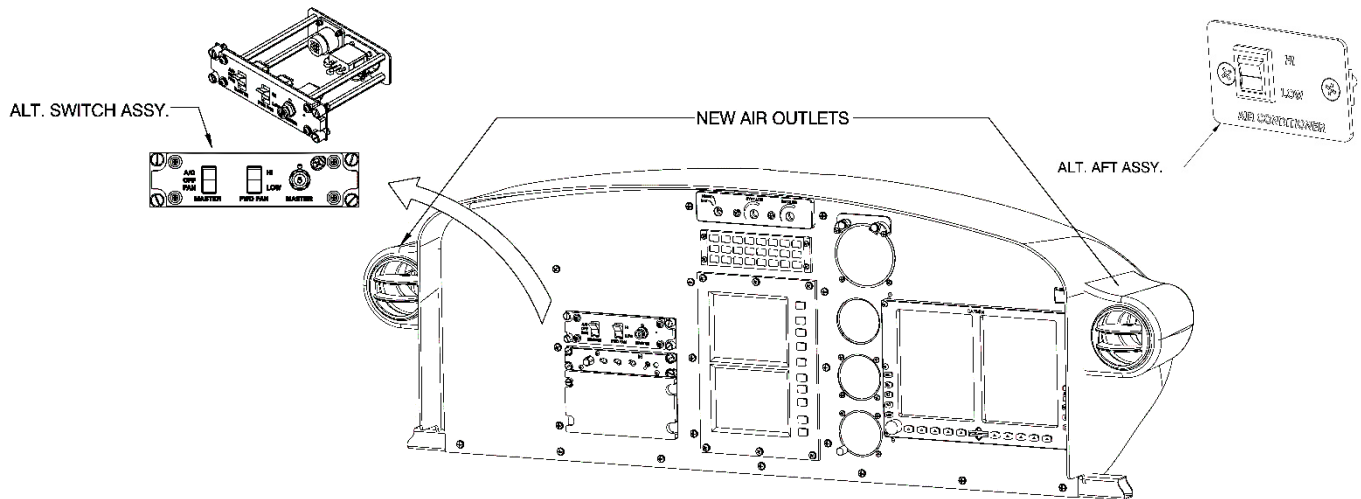

Figure 21-02: Equipment Locations for Air Conditioning System
with the -031 Configuration (Aft Mounted Condenser)

TITLE:
Air Conditioning System Installation Instructions For Continued
Airworthiness for Airbus Helicopters AS-350 B, C, D, D1, B1, B2, B3, BA &
EC-130 B4



(AS350 Old configuration)



(AS350 New configuration)

Figure 21 - 03: AEC Basic Configuration
(Top - Old config. / Bottom - New config.)

TITLE:
Air Conditioning System Installation Instructions For Continued
Airworthiness for Airbus Helicopters AS-350 B, C, D, D1, B1, B2, B3, BA &
EC-130 B4

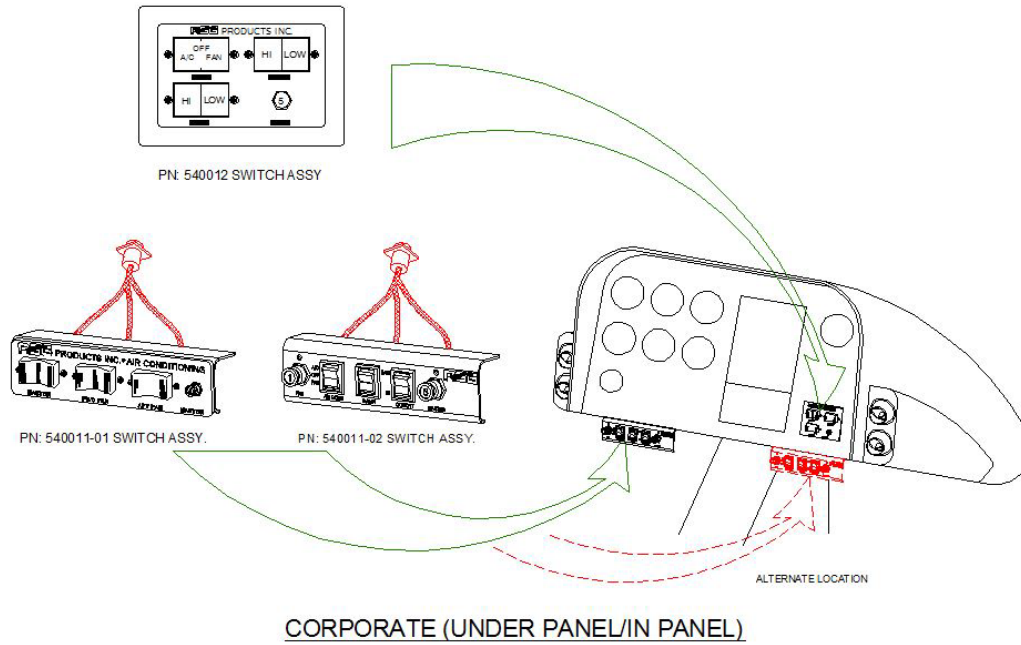

Figure 21 - 05: Corporate Configuration (EC130)

2. Removal/ Installation Forward Evaporator

(Ref. figures 21-06 and 21-07)

a) Removal

- 1) Access forward evaporator per Section 6-00-00 Dimensions and Access.
- 2) Connect refrigerant reclaimer to system in accordance with Section 21-00-00 and remove coolant from system. Comply with all Federal, State, and Local rules governing refrigerant handling.
- 3) Remove bolts securing evaporator.
- 4) Remove evaporator assembly.
- 5) Support evaporator while removing lines and other duct work.
- 6) Remove evaporator from aircraft.
- 7) Cap all open lines on unit and aircraft.
- 8) Disconnect electrical connections and remove evaporator fan.

b) Installation

- 1) Reinstall fan in aircraft and connect electrical connections.
- 2) Position evaporator against fan assembly and loosely install with securing hardware. Secure mounting hardware.
- 3) Reinstall drain line.
- 4) Connect duct work.
- 5) Ensure refrigerant O-rings are installed and in good condition. Replace as necessary. Oil all O-rings and fittings with refrigerant oil of the same type listed on the compressor. Torque refrigerant lines: #6 11-13 ft./lbs.; #8 15-20 ft./lbs.; #10 21-27 ft./lbs.
- 6) After completing other system functions and maintenance, charge system in accordance with Section 12-10-00.
- 7) Check for leaks per section 12-30-00

TITLE:
Air Conditioning System Installation Instructions For Continued
Airworthiness for Airbus Helicopters AS-350 B, C, D, D1, B1, B2, B3, BA &
EC-130 B4

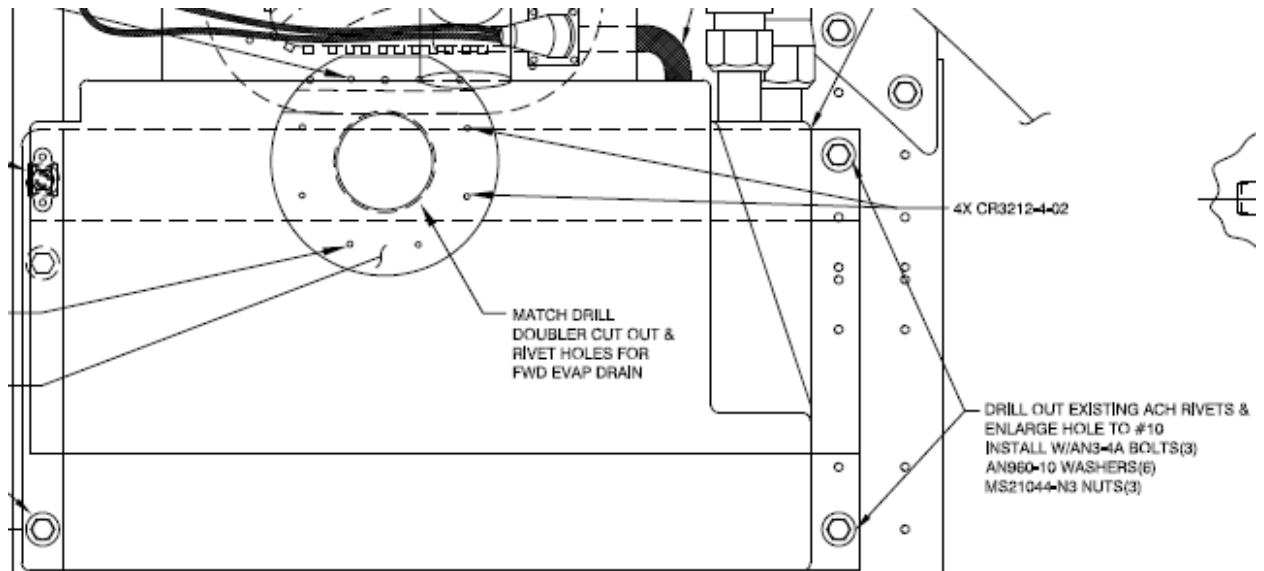

Figure 21 - 06: Forward Evaporator (AS-350)

FLUSH WITH PLATE, AND ATTACH WITH
5X AN3-5A BOLT
5X AN960-10 WASHER

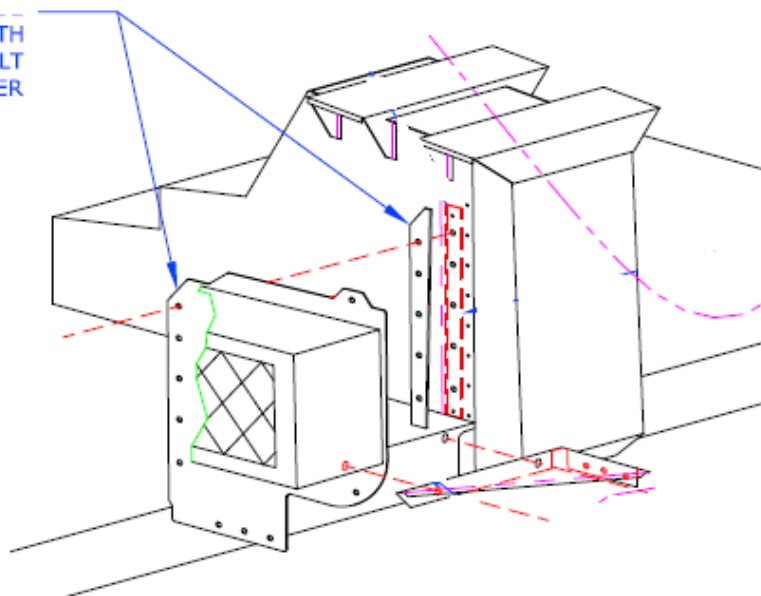

Figure 21 - 07: Forward Evaporator (EC-130)



DATE:
04/25/2025

DOC No.:
IFSE-0007

REV:
G

PAGE:
52 of 99

TITLE:
Air Conditioning System Installation Instructions For Continued
Airworthiness for Airbus Helicopters AS-350 B, C, D, D1, B1, B2, B3, BA &
EC-130 B4

3. Removal/ Installation Aft Evaporator

(Ref Figure 21-08)

a) Removal

- 1) Access aft evaporator (Ref. Section 6-00-00 Dimensions and access) and remove electrical connections.
- 2) Reclaim refrigerant in system in accordance with Section 12-10-00, to remove coolant from system.
- 3) Support evaporator while removing lines and duct work.
- 4) Cap all open lines on unit and aircraft.

b) Installation

- 1) Reinstall fan/evaporator and connect electrical connections.
- 2) Position evaporator and loosely install with securing hardware. Secure mounting hardware.
- 3) Reinstall drain line.
- 4) Connect duct work.
- 5) Ensure refrigerant O-rings are installed and in good condition. Replace as necessary. Oil all O-rings and fittings with refrigerant oil of the same type listed on the compressor. Torque refrigerant lines: #6 11-13 ft./lbs.; #8 15-20 ft./lbs.; #10 21-27 ft./lbs.
- 6) After completing other system functions and maintenance, charge system in accordance with Section 12-10-00.
- 7) Check for leaks per section 12-30-00.

TITLE:
Air Conditioning System Installation Instructions For Continued Airworthiness for Airbus Helicopters AS-350 B, C, D, D1, B1, B2, B3, BA & EC-130 B4

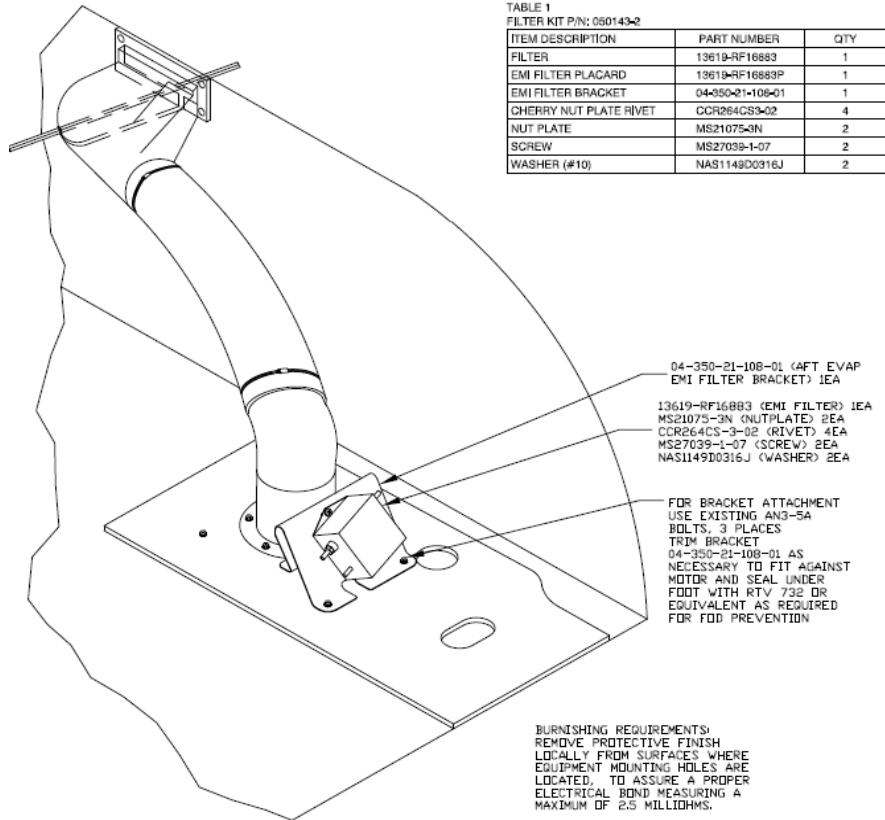

Figure 21 - 08: Aft Evaporator

4. Removal / Installation - Condenser

(Ref figures 21-09 and 21-10)

a) Removal

- 1) Access the condenser (Ref Section 6-00-00 Dimensions and Access)
- 2) Reclaim refrigerant in system in accordance with Section 12-10-00, to remove coolant from system.
- 3) Remove hardware securing condenser assembly. Disconnect blower wires and refrigerant hoses.
- 4) Remove condenser and cap all open lines on condenser and airframe.



DATE:
04/25/2025

DOC No.:
IFSE-0007

REV:
G

PAGE:
54 of 99

TITLE:
Air Conditioning System Installation Instructions For Continued
Airworthiness for Airbus Helicopters AS-350 B, C, D, D1, B1, B2, B3, BA &
EC-130 B4

b) Installation

- 1) Place condenser back in location.
- 2) Loosely install all hardware securing condenser assembly. Tighten mounting hardware only after all other hardware is installed.
- 3) Remove protective caps from refrigerant lines. Inspect that O-rings are installed and in good condition. Oil all O-rings and fittings with refrigerant oil of the same type listed on the compressor.
- 4) Install refrigerant lines. Torque refrigerant lines as follows: #6 11-13 ft./lbs.; #8 15-20 ft./lbs.; #10 21-27 ft./lbs. Do not over tighten.
- 5) Charge system in accordance with Section 12-10-00
- 6) Install 5" duct P/N: 060004

TITLE:
Air Conditioning System Installation Instructions For Continued
Airworthiness for Airbus Helicopters AS-350 B, C, D, D1, B1, B2, B3, BA &
EC-130 B4

BURNISHING REQUIREMENTS:
REMOVE PROTECTIVE FINISH LOCALLY FROM
SURFACES WHERE EQUIPMENT MOUNTING HOLES
ARE LOCATED, TO ASSURE A PROPER ELECTRICAL
BOND MEASURING A MAXIMUM OF 2.5 MILLIOHMS.

OPTIONAL INSTALL FOR NOISE REDUCTION WHEN BRUSHLESS
MOTORS ARE INSTALLED; P/Ns: IFSS 050143 DCB, -1 DCB,
-2 DCB, AND -3 DCB.
INSTALL THE FOLLOWING, MAINTAINING BURNISHING REQ:
13619-RF16883 (EMI FILTER) 2EA
MS27039-0807 (SCREW) 4EA
NAS620-8L (WASHER) 4EA

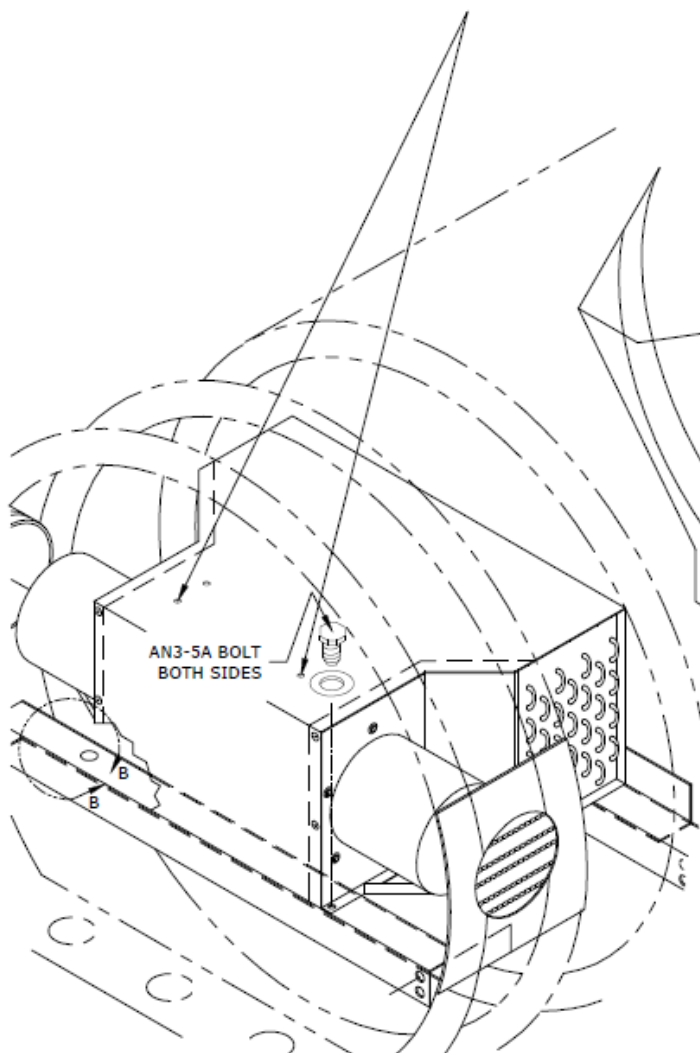

Figure 21 - 09: Aft Mounted Condenser (AS-350, EC-130)

TITLE:
Air Conditioning System Installation Instructions For Continued
Airworthiness for Airbus Helicopters AS-350 B, C, D, D1, B1, B2, B3, BA &
EC-130 B4

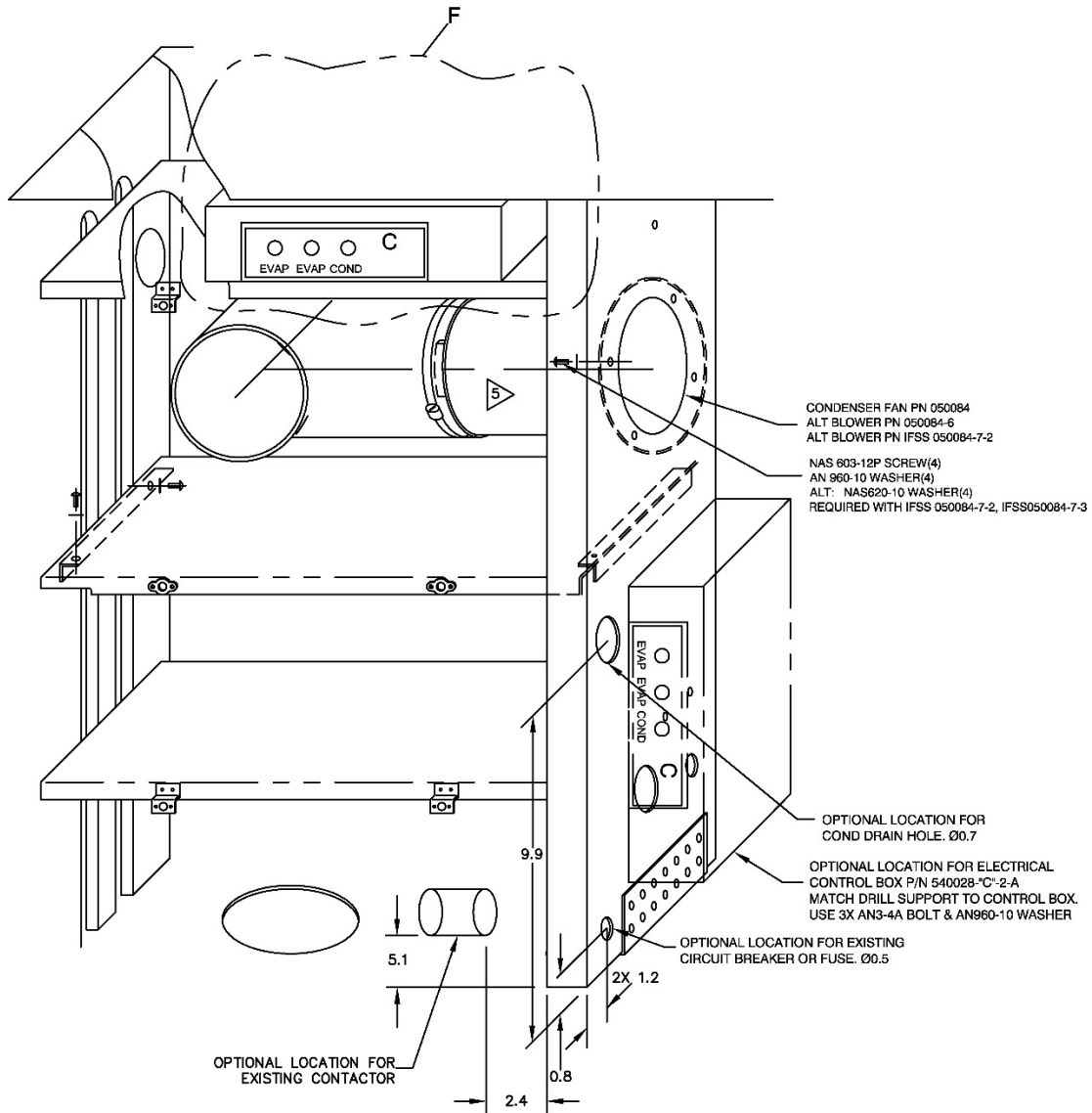

Figure 21 - 10: Side Mounted Condenser (AS-350)

5. Removal / Installation - Compressor

(Ref figure 21-11)

a) Removal

- 1) Access the compressor (Ref Section 6-00-00 Dimensions and Access)
- 2) Reclaim refrigerant in system in accordance with Section 12-10-00, to remove coolant from system.
- 3) Remove refrigerant lines from compressor and install protective caps to protect from foreign material entering system and compressor.
- 4) Disconnect drive belt to compressor.
- 5) Remove bolts securing compressor to mount and remove compressor.

b) Installation

- 1) Install compressor loosely on support frame with attaching hardware.
- 2) Install drive belt.
- 3) Tighten compressor bolts allowing compressor to "Seek" its own natural position on the frame. Tighten compressor belt tensioning bolt to 50 lbs. belt tension for PN 060018-1 Flat Belt, or 30 lbs. tension for PN 060005 Grooved Belt.
- 4) Tighten and safety all compressor mounting bolts.
- 5) Remove protective caps from refrigerant lines and compressor. Inspect the O-rings from installation and condition. Replace as necessary.
- 6) Oil all fittings and O-rings.
- 7) Install refrigerant lines.
- 8) Torque refrigerant lines: #6 11-13 ft./lbs.; #8 15-20 ft./lbs.; #10 21-27 ft./lbs. Do not over tighten.
- 9) Charge system in accordance with Section 12-00-00.
- 10) Install previously removed cowlings.

TITLE:
Air Conditioning System Installation Instructions For Continued
Airworthiness for Airbus Helicopters AS-350 B, C, D, D1, B1, B2, B3, BA &
EC-130 B4

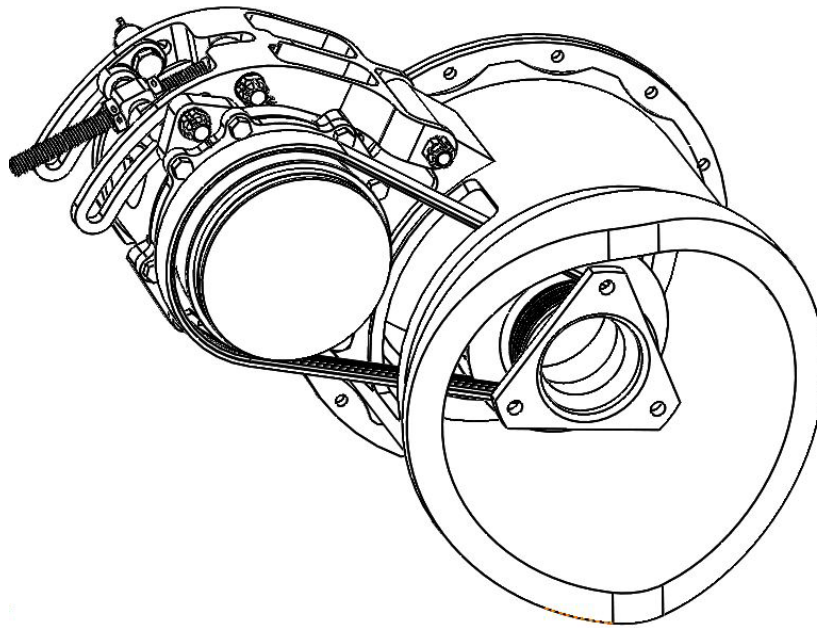

Figure 21 - 11: Compressor

6. Troubleshooting guide

Symptoms	Trouble	Cause	Correction
<ul style="list-style-type: none"> -Insufficient cooling -Low-side pressure too low -High -side pressure too low -Air in ducts only slightly cool 	Low or partial refrigerant charge	Leak	Find and fix the leak. If there was a loss of oil, be sure to check to compressor oil level. Evacuate and recharge per section 12.10.00
<ul style="list-style-type: none"> - Insufficient cooling during hottest part of the day or during extended flying. - Low-side pressure normal, though it may be too low or even a vacuum - High-side pressure normal, though it may be low-at the same time low side is low - Air in the ducts is usually cold, but becomes warm when pressure reading drop 	Excessive moisture in the system	The desiccant in the drier/receiver is saturated	Replace or rebuild the receiver/drier. Evacuate and recharge per section 12.10.00
<ul style="list-style-type: none"> - Insufficient cooling - Low-side pressure normal, but does not drop when the clutch cycles - High-side pressure high - Air in ducts only slight cool 	Air in the System	Refrigerant contains non-condensable in the form of air moisture	Leak test, watch for bad compressor seals. Drain the system. Repair leaks as needed. Replace or rebuild the receiver-drier. Check the compressor oil. Evacuate and recharge per section 12.10.00.
<ul style="list-style-type: none"> - No cooling - Low-side pressure too high - High-side pressure too high - Liquid line very hot - Air in ducts is warm 	Condenser malfunction or system overcharge	Condenser malfunction or system overcharge	Evacuate and recharge per section 12.10.00 or replace condenser.

Section 21-10-00 Illustrated Parts List

1. General

This section contains information on parts for the Air Conditioning System Installation, for use in ordering replacements if necessary.

Air Outlets

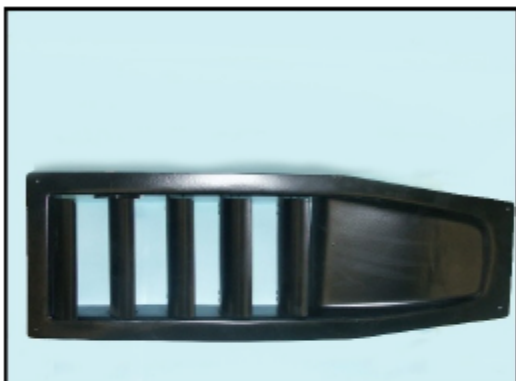

RSG PN: 520071-1
**Condenser Air Intake
Assembly Low Profile
(Sliding Door)**

AS350 



RSG PN: 500001
Left Side Air Outlet

EC130 



RSG PN: 500002
Right Side Air Outlet

EC130 

Air Outlets

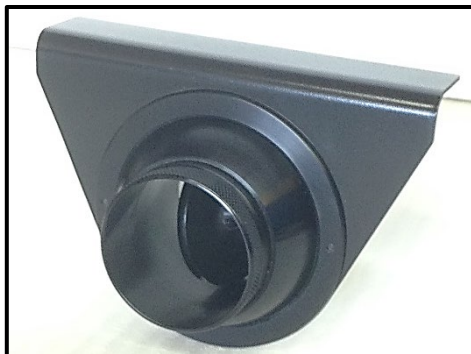

RSG PN: 510259-3
Air Outlet Assembly

AS350 

EC130 

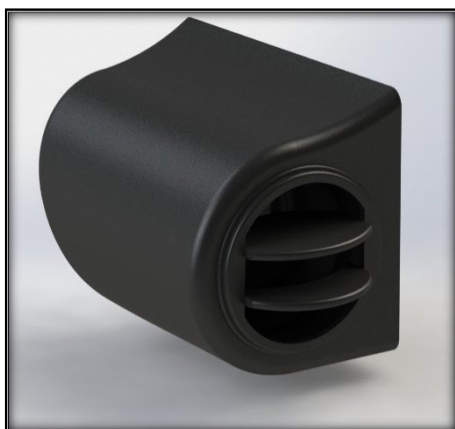

RSG PN: 520156HP-01
Air Outlet L.H.

AS350 

EC130 

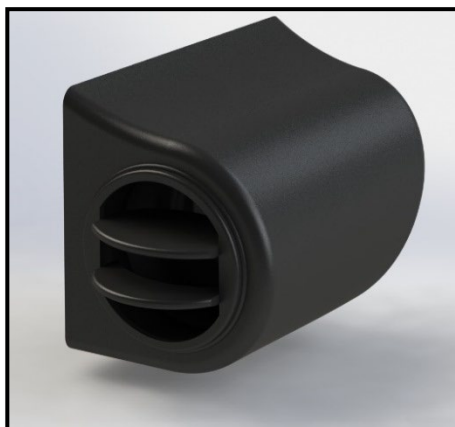

RSG PN: 520157HP-01
Air Outlet R.H.

AS350 

EC130 

Blower Motors



RSG PN:IFSS 050143-2 DCB
-3 DCB

**5" Vane Axial Blower
Assembly**

AS350 

EC130 



RSG PN: 050052-1
**Blower Motor,
Modified Right Half**

AS350 



RSG PN: 490017-1-02
**Aft Evaporator Fan
Assembly**

AS350 

TITLE:
Air Conditioning System Installation Instructions For Continued
Airworthiness for Airbus Helicopters AS-350 B, C, D, D1, B1, B2, B3, BA &
EC-130 B4

Blower Motor Part



RSG PN: 040004-8
Fan Wheel CW

AS350 

EC130 

Compressors



RSG PN: 590008
**Compressor
Assembly**

AS350 

EC130 

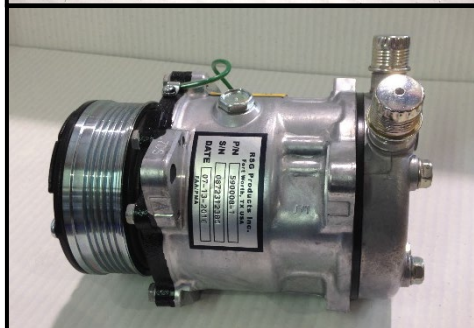

RSG PN: 590008-1
**Compressor
Assembly**

AS350 

EC130 

Compressor Parts



RSG PN: 050033
Coil, 24 VDC

AS350 

EC130 

Compressor Parts



RSG PN: 060005
**24.3" 4 Groove
Serpentine Belt**

AS350 

EC130 



RSG PN: 060018 25-1/4"
RSG PN: 060018-1 25"
Flat Belt

AS350 

EC130 

Compressor Bracket/Parts



RSG PN: 04-130-21-101-01
**Compressor Mount
Bracket**

AS350 

EC130 

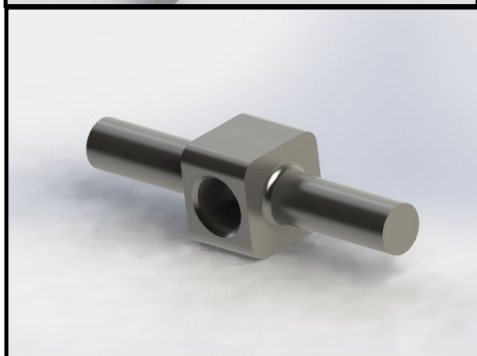

RSG PN: 04-130-21-102-01
**Compressor Mount
Tension Bolt**

AS350 

EC130 

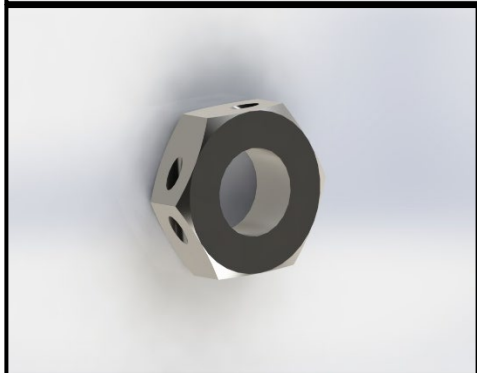

RSG PN: 04-130-21-104-01
Jam Nut Drilled

AS350 

EC130 

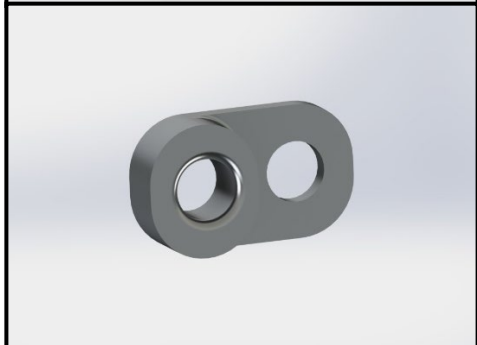

RSG PN: 04-130-21-105-01
Compressor Clamp

AS350 

EC130 

Compressor Bracket/Parts

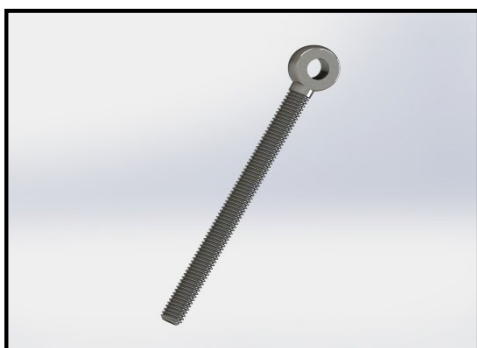

RSG PN: 2434K39
Threaded Rod End

AS350



EC130

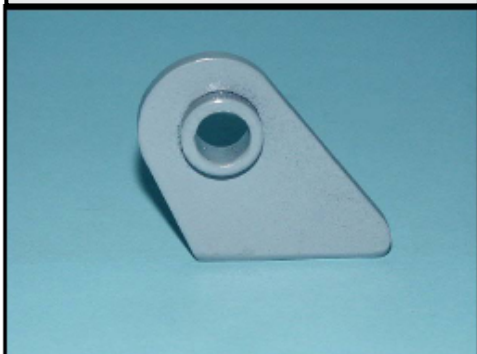

RSG PN: 530100-1
**Strap, Housing Mod
Assembly**

AS350



EC130



RSG PN: 300363-2
**Compressor Shim, Upper
(Alt: 261155 not shown)**

AS350



EC130



Compressor Bracket/Parts



RSG PN: 300067-1 Compressor Standoff

AS350 

EC130 



RSG PN: 261007 Bushings, SD507

AS350 

EC130 



RSG PN: 300095 Compressor Pin

AS350 

EC130 

Condenser/Evaporator



RSG PN: 090002-O
Expansion Valve

AS350 

EC130 



RSG PN: 090016-5
Receiver/Drier

AS350 

EC130 



RSG PN: 550003-O
**Aft Condenser
Assembly**

EC130 



RSG PN: 550007-1
**Side Condenser
Assembly**

AS350 

Condenser/Evaporator

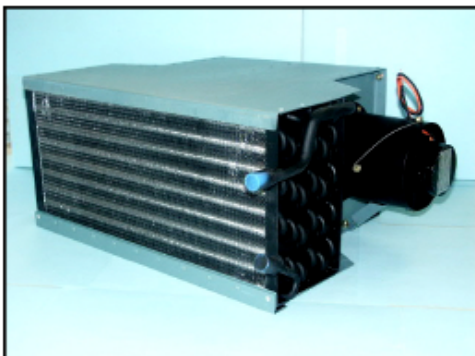

RSG PN: 550022
**Aft Condenser
Assembly**

AS350 



RSG PN: 560004
**Fwd Evaporator
Assembly**

EC130 



RSG PN: 560010-O-5
**Aft Evaporator
Assembly**

AS350 



RSG PN: 560016-O-1
**Aft Evaporator
Assembly**

EC130 

TITLE:
Air Conditioning System Installation Instructions For Continued
Airworthiness for Airbus Helicopters AS-350 B, C, D, D1, B1, B2, B3, BA &
EC-130 B4

Condenser/Evaporator



RSG PN: 560025-O-01

-02

**Fwd Evaporator
Assembly**

AS350 

Electrical Parts



RSG PN: 540009
**Electrical Box
Assembly**

EC130 



RSG PN: 540028-C-1-A
-C-2-A
**Electrical Box
Assembly**

AS350 



RSG PN: 540011-01
-02
**Instrument Panel
Switch**

EC130 



RSG PN: 540044-5
Harness Assembly

AS350 

Electrical Parts



RSG PN: 540044-8-01
-02

**Instrument Panel
Switch**

AS350 



RSG PN: 540044-9
**5 amp Breaker
Assembly**

AS350 

EC130 



RSG PN: 540089-01
-02
**Aft Evaporator Switch
Assembly**

AS350 

Electrical Parts



RSG PN: 050000
Switch with Button

AS350 

EC130 



RSG PN: 050001
Switch without Button

AS350 

EC130 



RSG PN: 050006
Switch without Button

AS350 

EC130 



RSG PN: 050006-2
Switch with Button

AS350 

EC130 

Electrical Parts



RSG PN: 050007-1
Button



RSG PN: 050007-3
Button



RSG PN: 050007-4
Button



RSG PN: 050008
Relay

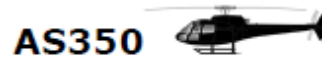

Electrical Parts

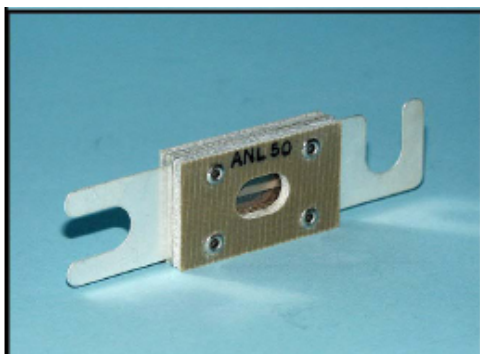

RSG PN: 050015-2
50 Amp Limiter

AS350 

EC130 



RSG PN: 050026
Timer

AS350 

EC130 



RSG PN: 050107
Low Pressure Switch

AS350 

EC130 



RSG PN: 090004
High Pressure Switch

AS350 

EC130 

Electrical Parts

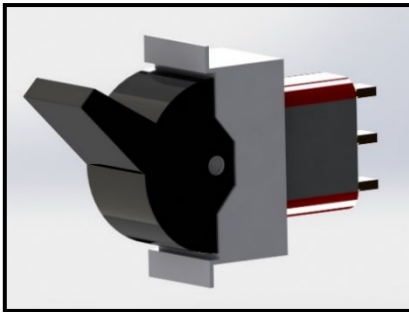

RSG PN: 7303J21ZQI22
Switch, 3PDT, 3 POS.

AS350 

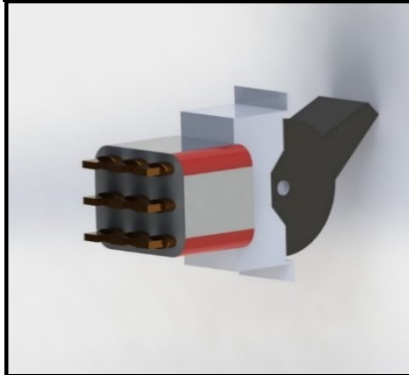

RSG PN: 7301J21ZGE22
Switch, 3PDT, 3 POS.

AS350 

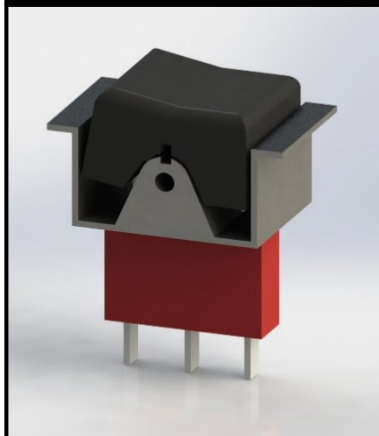

RSG PN: 7301J11ZQE22
Switch, SPST, 2 POS.

AS350 

Electrical Parts

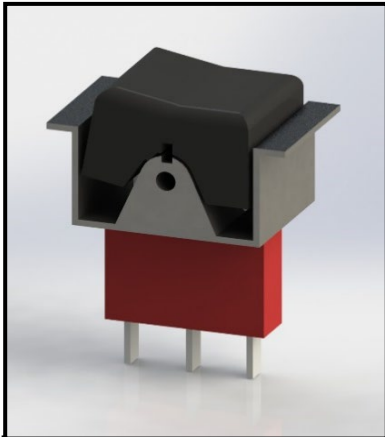

RSG PN: 7101J51ZQE22
Switch, SPST, 2 POS.

EC130 

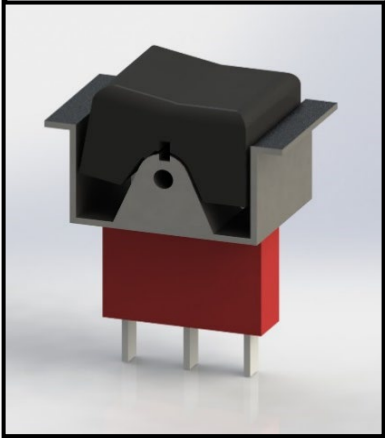

RSG PN: 7203J51ZQE22
Switch, DPDT, 2 POS.

EC130 

EC130 Hoses



RSG PN: 570103
**High Pressure Hose #6
Assembly**

EC130 



RSG PN: 570104
**Condenser to
Receiver/Drier Hose #6
Assembly**

EC130 



RSG PN: 570105
**Return Hose #10
Assembly**

EC130 

AS350 Hoses



RSG PN: 570067-O-A
Hose Assembly #6
Condenser to Drier

AS350 



RSG PN: 570070-O-A-01
Hose Assembly #8
Compressor Discharge

AS350 



RSG PN: 570070-O-A-02
Hose Assembly #8
Compressor Discharge

AS350 



RSG PN: 570020-O-A
Hose Assembly #6
Condenser to Drier

AS350 

AS350 Hoses



RSG PN: 570024-O-A-01
Hose Assembly #8
Compressor Discharge

AS350 



RSG PN: 570024-O-A-02
Hose Assembly #8
Compressor Discharge

AS350 



RSG PN: 570072-O-A
Hose Assembly #6 Fwd
Evaporator to Receiver/Drier

AS350 

AS350 Hoses



RSG PN: 570087-O-A-01
**Hose Assembly Fwd
Evaporator to Aft Evaporator
to Compressor**

AS350 



RSG PN: 570087-O-A-02
**Hose Assembly Fwd
Evaporator to Aft Evaporator
to Compressor**

AS350 

BRUSHLESS BLOWER MOTORS



RSG PN: IFSS 050084-7-2
**7" DC Brushless Blower
Assembly Short**

AS350 

EC130 



RSG PN: IFSS 050084-7-3
**7" DC Brushless Blower
Assembly Long**

AS350 

EC130 



TITLE:
Air Conditioning System Installation Instructions For Continued Airworthiness for Airbus Helicopters AS-350 B, C, D, D1, B1, B2, B3, BA & EC-130 B4

LIST OF CONSUMABLE MATERIALS

DESCRIPTION	P/N	VENDOR/SPECIFICATION
THREAD LOCK	242	LOCTITE
ADHESIVE	1300L	3M
Cleaning cloth, Low-Lint	--	Commercial
Mineral Spirits, Cleaning Solvent	--	MIL-PRF-680, TYP II OR ASTM-D235
Alodine	Alodine 1200	--
Alodine	Iridite 14-2	--
Paint Stripper	Turco 5873	--
Polyamide Paint Primer	--	--
Dye Penetrant Kit	--	--
Acetone	--	ASTM-D329
Isopropyl Alcohol	--	TT-I-735
Trichloroethane	--	MIL-T-81533
Nylon Scouring Pad	(3M) Scotchbrite 63	3M
240 Grit Sandpaper	--	Commercial
320 Grit Sandpaper	--	Commercial
240 Grit Aluminum Oxide Abrasive	--	Commercial
Cloth	--	Commercial
Sealant	--	MIL-S-8802
Adhesive transfer tape 950 (2")	70-0060-3057-4	3M
Refrigerant	R134a	--

Chapter 98

Section 98-00-00 Wiring Diagrams and Plumbing Schematics

This section contains all applicable wiring diagrams and plumbing schematics.

TITLE:
Air Conditioning System Installation Instructions For Continued
Airworthiness for Airbus Helicopters AS-350 B, C, D, D1, B1, B2, B3, BA &
EC-130 B4

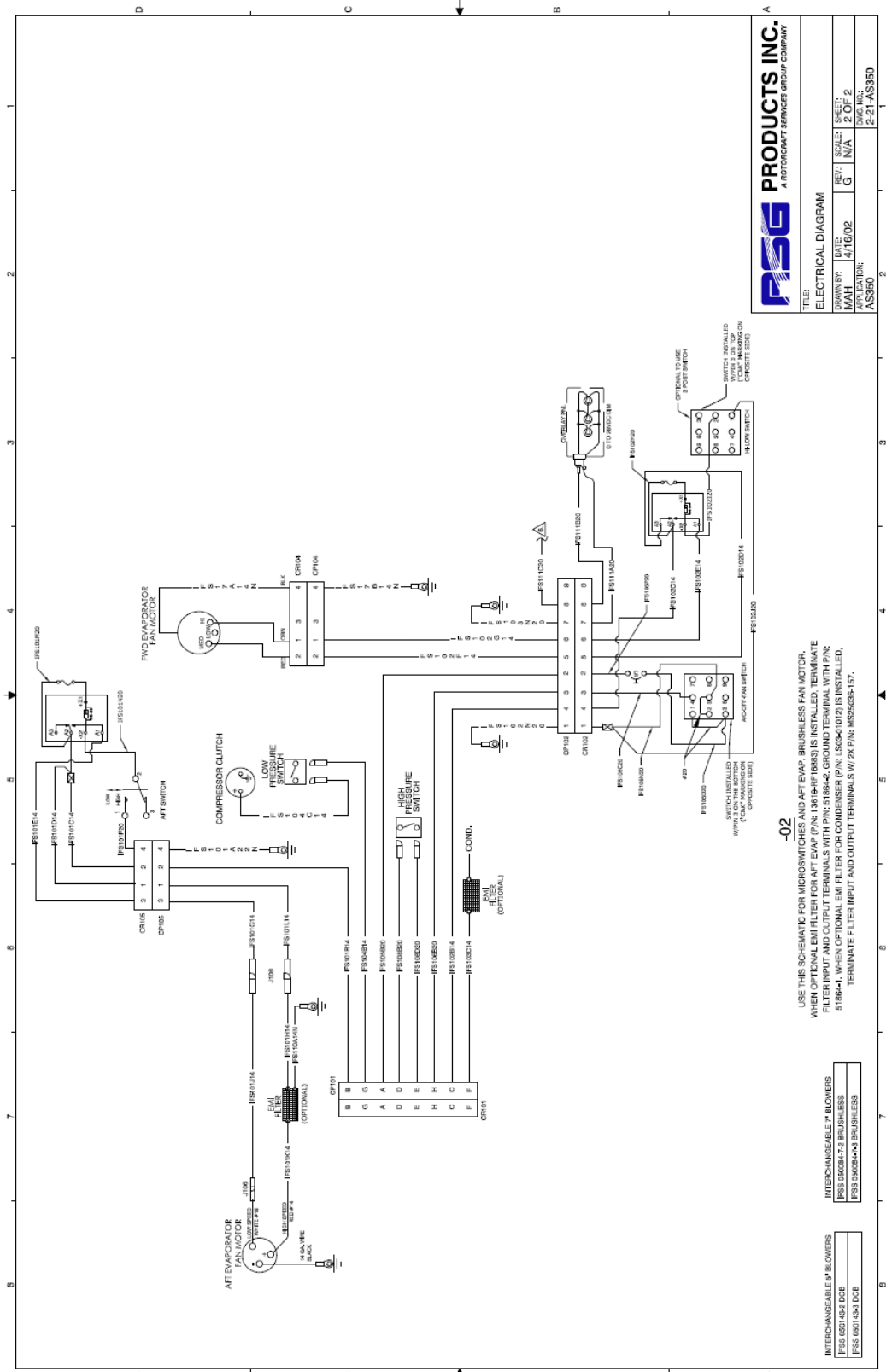

PSG PRODUCTS INC.
A ROTORCAFT SERVICES GROUP COMPANY

ELECTRICAL DIAGRAM

DATE:	REV.:	SCALE:	SHEET:
4/16/02	G	N/A	2 OF 2
MAH			
AS350			2-21-AS350

-02

USE THIS SCHEMATIC FOR MICROSWITCHES AND AFT EVAP. BRUSHLESS FAN MOTOR. WHEN OPTIONAL EMF FILTER FOR AFT EVAP (P/N: 150290102) IS INSTALLED, TERMINATE FILTER INPUT AND OUTPUT TERMINALS WITH P/N: 150290102. GROUND TERMINAL WITH P/N: 150290102. WHEN OPTIONAL EMF FILTER FOR CONDENSER (P/N: 150290102) IS INSTALLED, TERMINATE FILTER INPUT AND OUTPUT TERMINALS WITH P/N: 150290102.

INTERCHANGEABLE * BLOWERS
P/N: 150290102
P/N: 150290102

INTERCHANGEABLE * BLOWERS
P/N: 150290102
P/N: 150290102

TITLE: Air Conditioning System Installation Instructions For Continued Airworthiness for Airbus Helicopters AS-350 B, C, D, D1, B1, B2, B3, BA & EC-130 B4

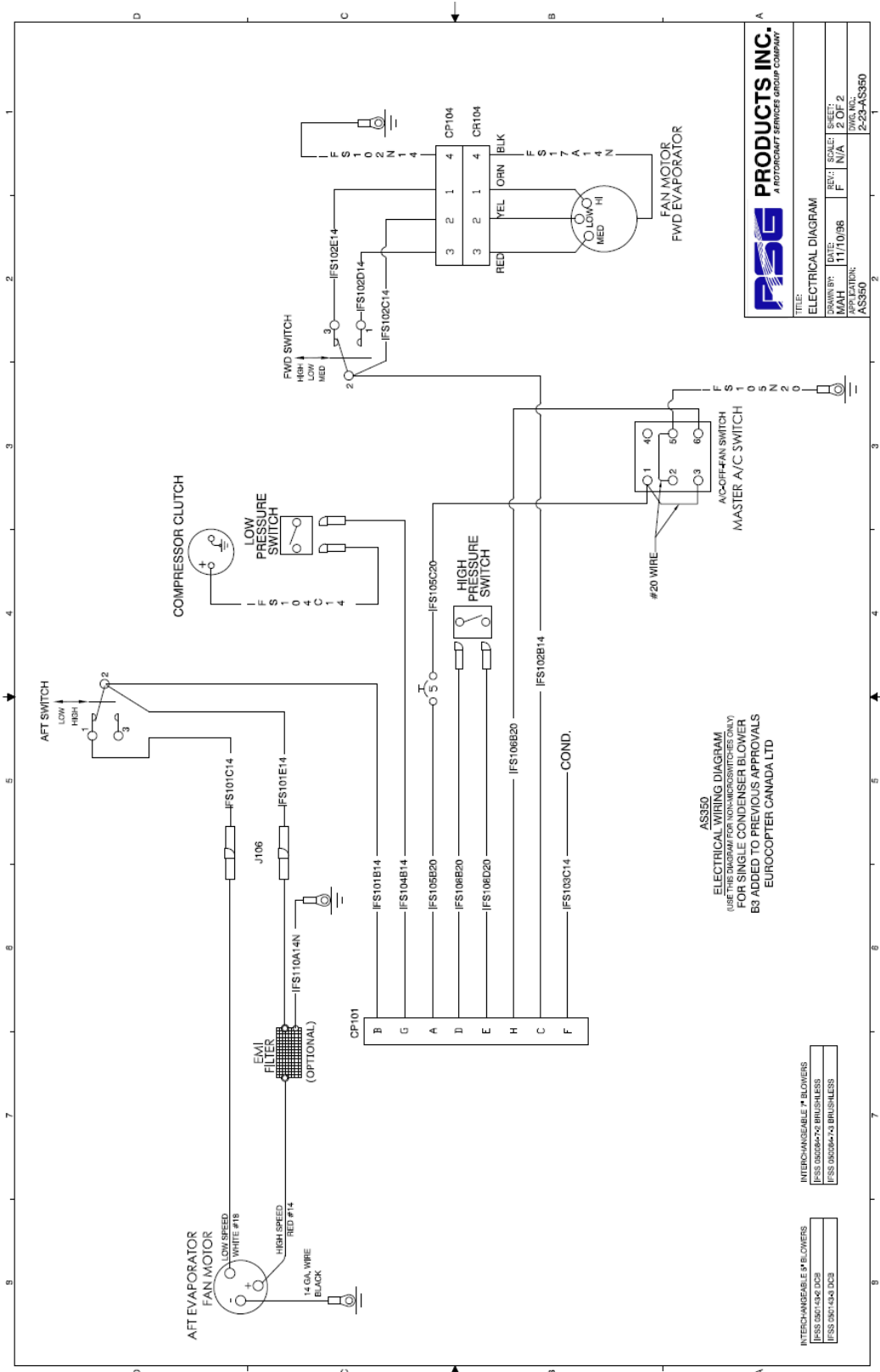

RSG PRODUCTS INC.
A ROTORCRAFT SERVICE GROUP COMPANY

TITLE: ELECTRICAL DIAGRAM
DRAWN BY: DATE: 11/10/98
MAH: REV: SCALE: N/A
REV: 2 OF 2
PART NO.: 2-23-ASS90
ASS90

ASS90
ELECTRICAL WIRING DIAGRAM
FOR SINGLE CONDENSER BLOWER
B3 ADDED TO PREVIOUS APPROVALS
EUROCOPTER CANADA LTD

INTERCHANGEABLE * BLOWERS
IFS 0009M-72 BRUSHLESS
IFS 0009M-72 BRUSHLESS

INTERCHANGEABLE * BLOWERS
IFS 0007-140 D23
IFS 0007-140 D23

TITLE:
Air Conditioning System Installation Instructions For Continued
Airworthiness for Airbus Helicopters AS-350 B, C, D, D1, B1, B2, B3, BA &
EC-130 B4

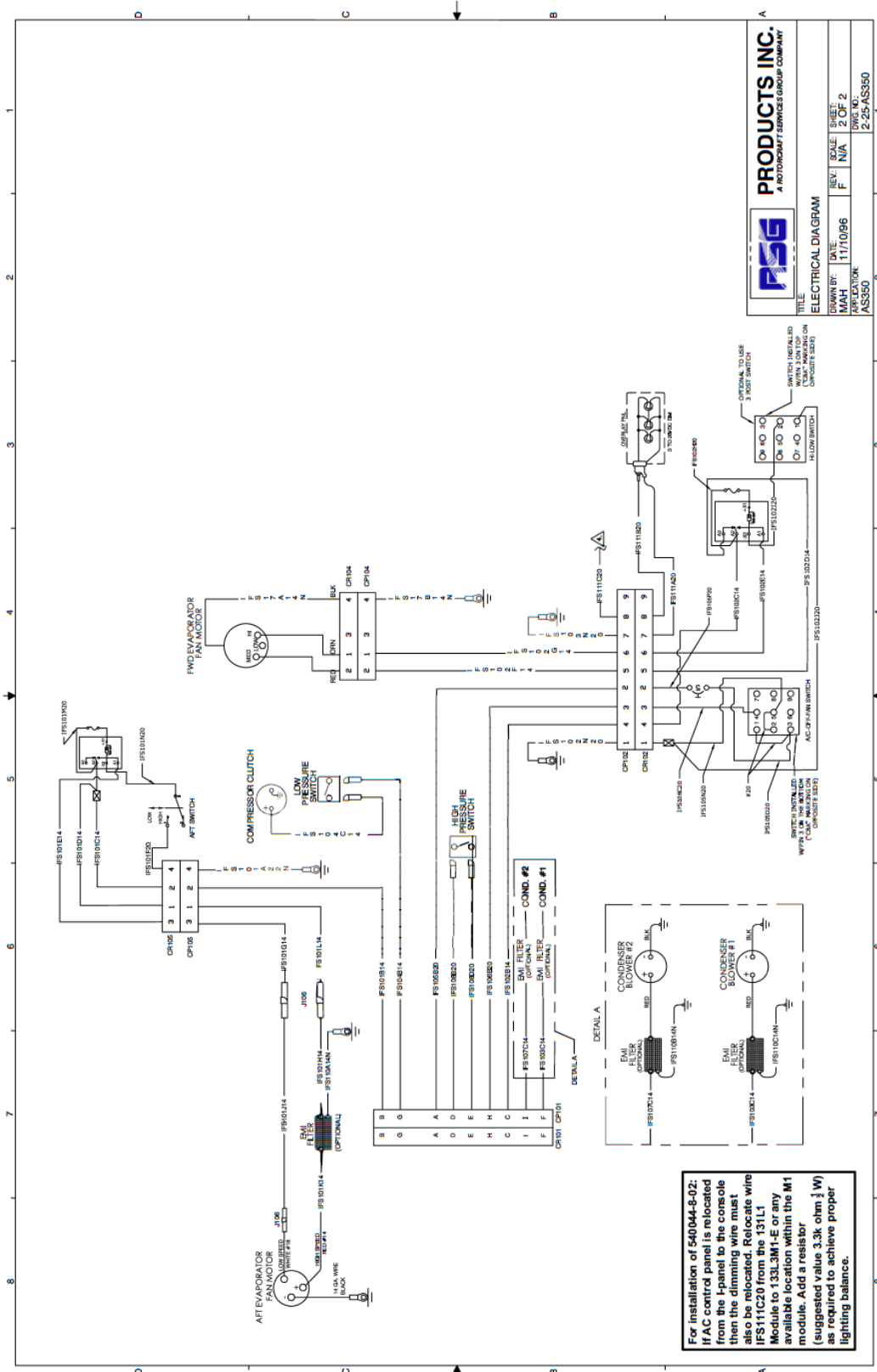

TITLE: Air Conditioning System Installation Instructions For Continued Airworthiness for Airbus Helicopters AS-350 B, C, D, D1, B1, B2, B3, BA & EC-130 B4

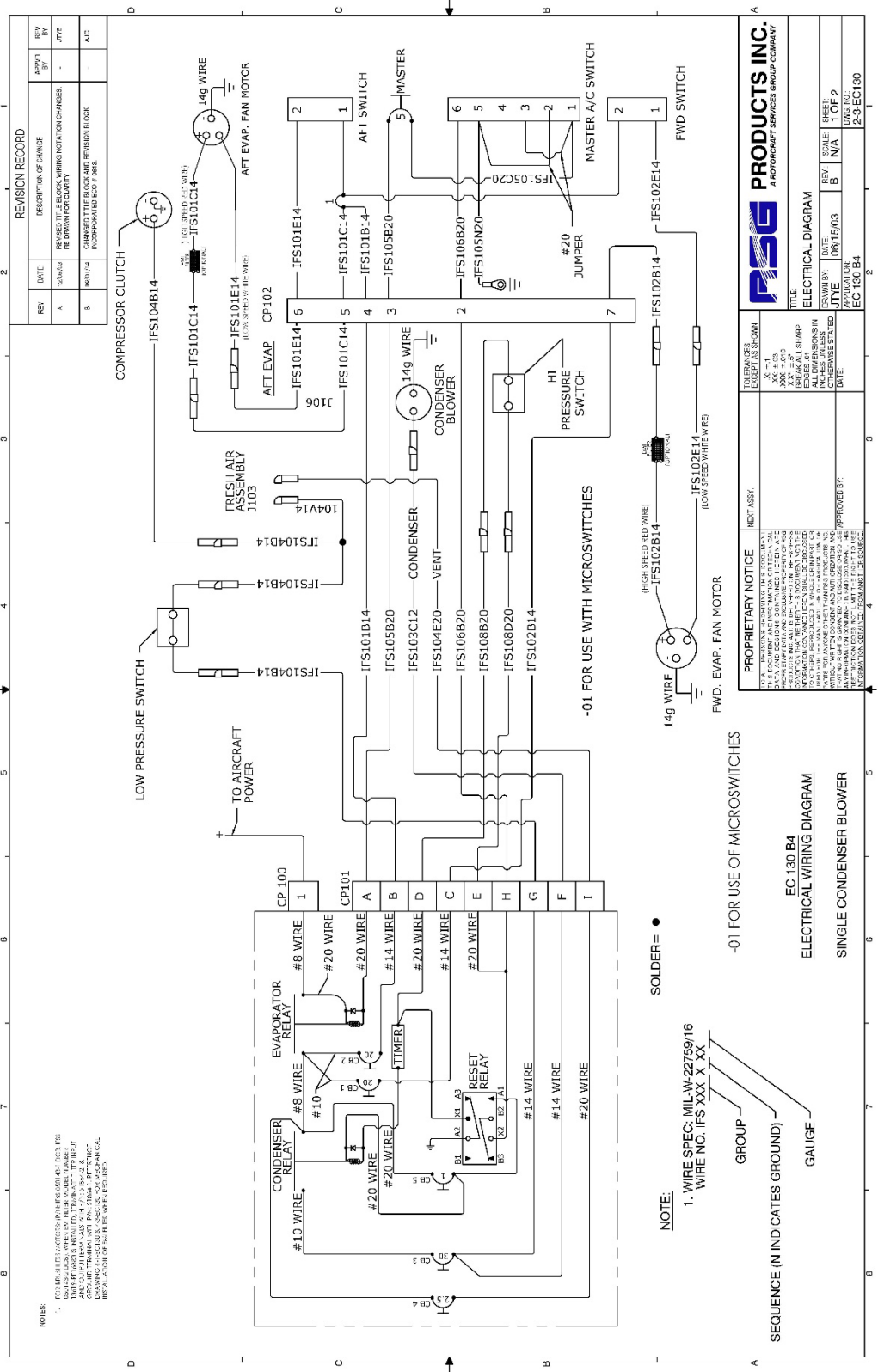

REVISION RECORD

REV	DATE	DESCRIPTION OF CHANGE	APPROVED BY	DATE
A	02/03/01	REVISED (1) LEBACK, (2) WIRING NOTATION CHANGES, (3) REORGANIZED CLUTCH		
B	06/01/04	CHANGED TITLE BLOCK AND REVISION BLOCK TO INCORPORATE ECU 2-9-EC130		

PROPRIETARY NOTICE

TELEPHONE: 800-368-5800

EXCEPT AS SHOWN

ALL DIMENSIONS IN INCHES UNLESS OTHERWISE STATED

DATE: 08/15/03

REV: B

SCALE: 1:1

DATE: 08/15/03

REV: 2

SCALE: 1:1

DATE: 08/15/03

REV: 2

SCALE: 1:1

DATE: 08/15/03

REV: 2

SCALE: 1:1

SEQUENCE (N INDICATES GROUND)

GROUP

GAUGE

NOTE: 1. WIRE SPEC: MIL-W-22759/16 WIRE NO. IFS XXX X XX

EC-130 B4 ELECTRICAL WIRING DIAGRAM SINGLE CONDENSER BLOWER

TITLE: Air Conditioning System Installation Instructions For Continued Airworthiness for Airbus Helicopters AS-350 B, C, D, D1, B1, B2, B3, BA & EC-130 B4

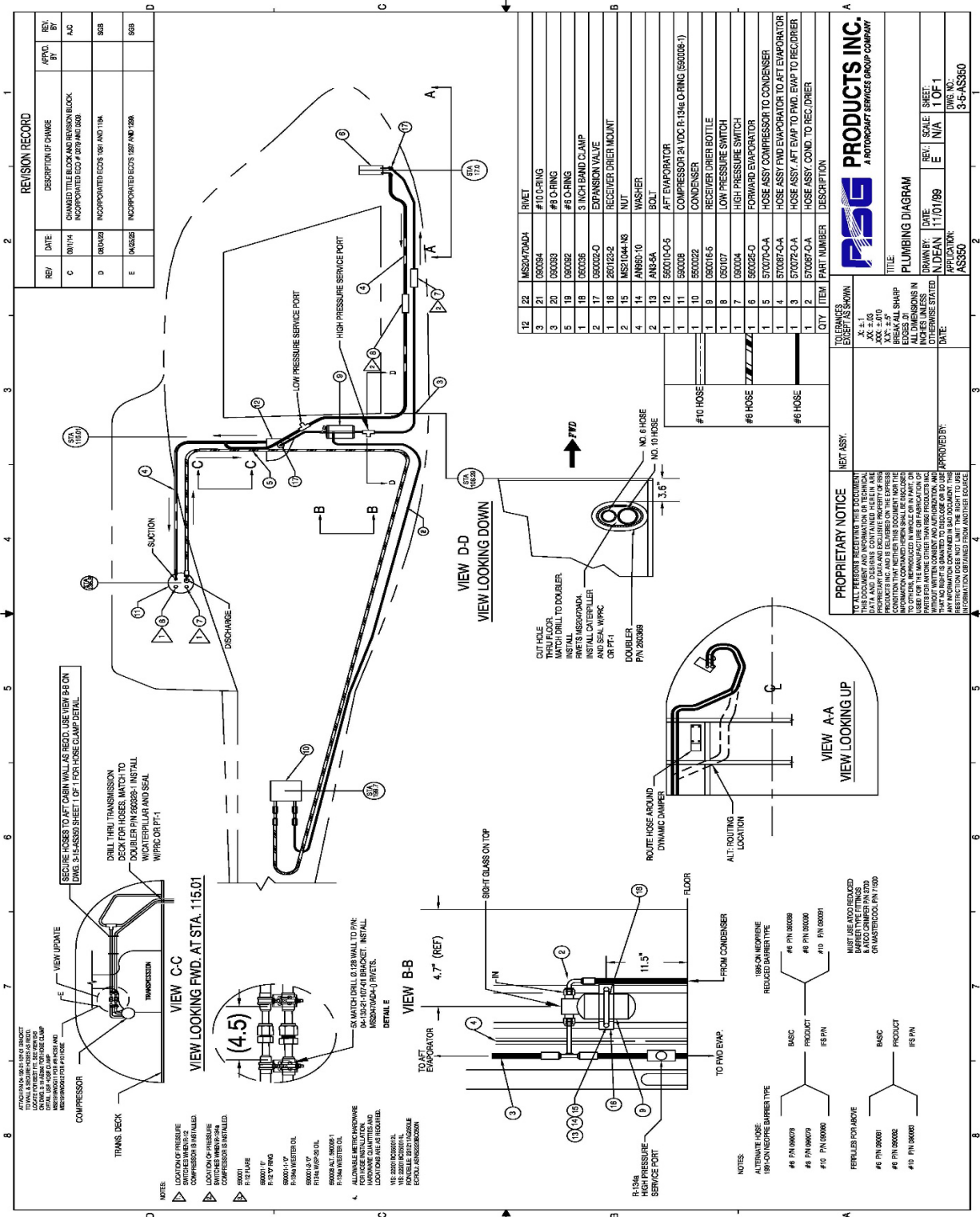

REV.	DATE	DESCRIPTION OF CHANGE	APPROV. BY
C	08/17/14	CHANGED THE BLOCK AND WAXY BLOCK ACCORDING TO 3-15-ASS60 SHEET 1 OF 1 FOR HOSE CLAMP DETAIL.	AJC
D	08/04/21	INCORPORATED ECOS 101 AND 110A	SSB
E	04/25/25	INCORPORATED ECOS 107 AND 108	SSB

QTY	ITEM	DESCRIPTION
12	MS20470A24	RIVET
3	21	050044 #10 O-RING
3	20	050333 #8 O-RING
5	19	050352 #6 O-RING
1	18	050208 3 INCH BAND CLAMP
2	17	050205-O EXPANSION VALVE
1	16	2610123-2 RECEIVER DRIER MOUNT
2	15	MS21044-N3 NUT
4	14	AN867-10 WASHER
2	13	AN8-8A BOLT
1	12	56010-A-5 AFT EVAPORATOR
1	11	560208 COMPRESSOR 24 VDC R.1046 O-RING (560208-1)
1	10	560322 CONDENSER
1	9	050107-5 RECEIVER DRIER BOTTLE
1	8	050107 LOW PRESSURE SWITCH
1	7	050004 HIGH PRESSURE SWITCH
1	6	560208-O FORWARD EVAPORATOR
1	5	570702-O-A HOSE ASSY COMPRESSOR TO CONDENSER
1	4	570702-O-A HOSE ASSY FWD EVAPORATOR TO AFT EVAPORATOR
1	3	570702-O-A HOSE ASSY AFT EVAP. TO FWD. EVAP. TO RECEIVER
1	2	570702-O-A HOSE ASSY COND. TO REC. DRIER

RSG PRODUCTS INC.
A ROTORCRAFT SERVICES GROUP COMPANY

TITLE: PLUMBING DIAGRAM
DRAWN BY: N. DEAN
DATE: 11/01/89
SCALE: N/A
SHEET: 1 OF 1
REV: E
JOB NO.: 3-5-ASS60

PROPRIETARY NOTICE
TO ALL PERSONS RECEIVING THIS DOCUMENT: THIS A/C PART AND INFORMATION IS TECHNICAL PROPRIETARY DATA AND EXCLUSIVE PROPERTY OF RSG. IT IS TO BE KEPT CONFIDENTIAL AND NOT TO BE REPRODUCED OR TRANSMITTED IN ANY FORM OR BY ANY MEANS, ELECTRONIC OR MECHANICAL, INCLUDING PHOTOCOPYING, RECORDING, OR BY ANY INFORMATION STORAGE AND RETRIEVAL SYSTEM, WITHOUT THE WRITTEN CONSENT AND AUTHORIZATION OF RSG. THIS A/C PART IS ISSUED FOR THE USE OF THE AIRCRAFT FOR WHICH IT IS SPECIFICALLY DESIGNED. RSG MAKES NO WARRANTY OR REPRESENTATION, AND ACCEPTS NO LIABILITY, FOR THE USE OF THIS A/C PART IN ANY OTHER APPLICATION. RSG'S LIABILITY IS LIMITED TO THE EXTENT OF THE INFORMATION OBTAINED FROM ANOTHER SOURCE.

APPROVED BY: _____

TITLE: Air Conditioning System Installation Instructions For Continued Airworthiness for Airbus Helicopters AS-350 B, C, D, D1, B1, B2, B3, BA & EC-130 B4

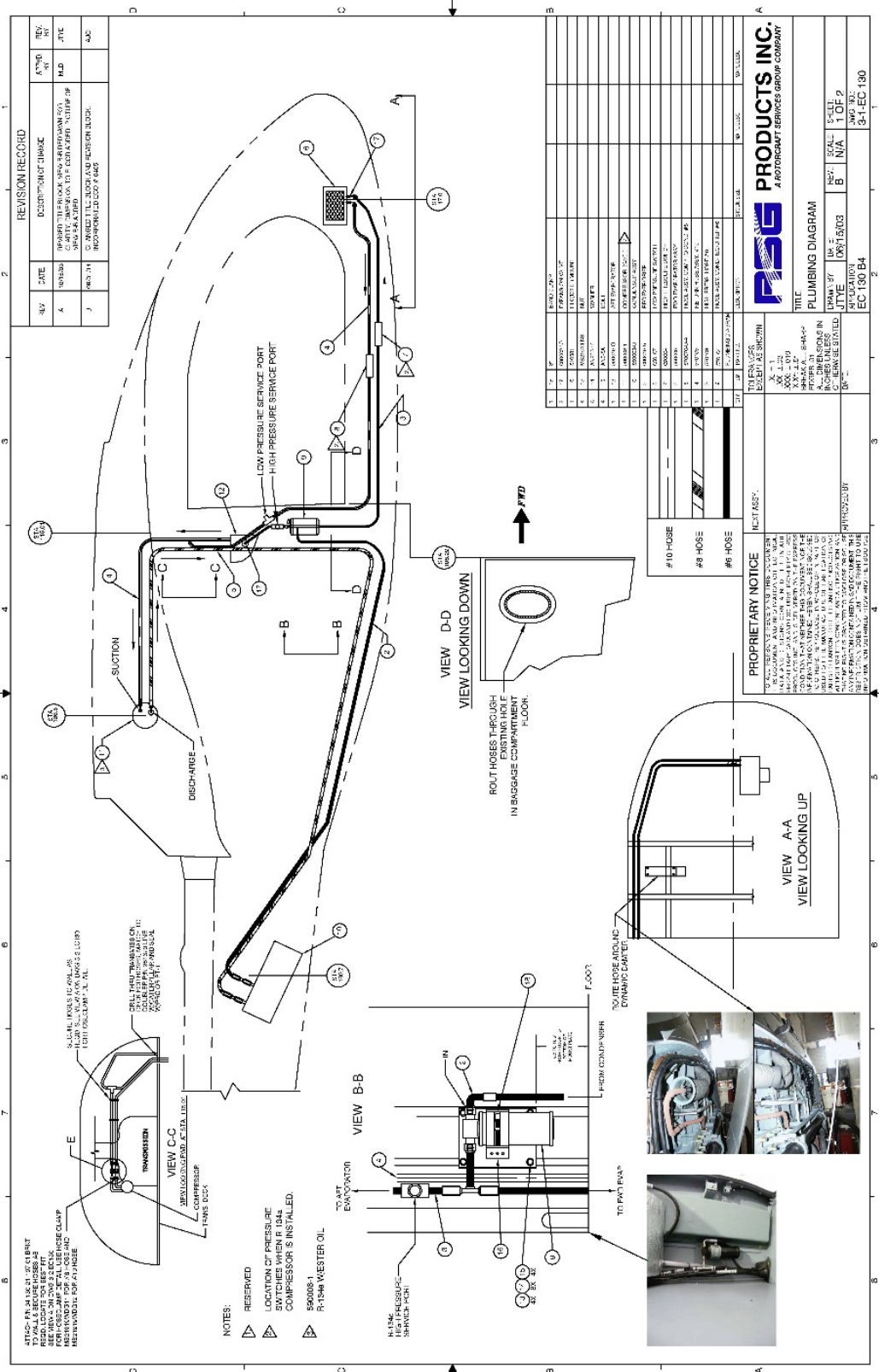

REVISION RECORD

REV.	DATE	DESCRIPTION/CHANGE	APP'D BY	REV. BY
A	08/05/03	ISSUED FOR PRODUCTION	JTC	JTC
B	08/05/03	ISSUED FOR PRODUCTION	JTC	JTC
C	08/05/03	ISSUED FOR PRODUCTION	JTC	JTC
D	08/05/03	ISSUED FOR PRODUCTION	JTC	JTC
E	08/05/03	ISSUED FOR PRODUCTION	JTC	JTC
F	08/05/03	ISSUED FOR PRODUCTION	JTC	JTC
G	08/05/03	ISSUED FOR PRODUCTION	JTC	JTC
H	08/05/03	ISSUED FOR PRODUCTION	JTC	JTC
I	08/05/03	ISSUED FOR PRODUCTION	JTC	JTC
J	08/05/03	ISSUED FOR PRODUCTION	JTC	JTC

PROPRIETARY NOTICE
 RSG PRODUCTS INC. is the owner of the intellectual property rights in the design and manufacture of the equipment shown herein. All rights are reserved. No part of this document may be reproduced or transmitted in any form or by any means, electronic or mechanical, including photocopying, recording, or by any information storage and retrieval system, without the prior written permission of RSG PRODUCTS INC.

PLUMBING DIAGRAM
 DRAWN BY: JTC
 CHECKED BY: JTC
 DATE: 08/05/03
 SCALE: 1 OF 2
 SHEET: 34-1-EC-130



DATE:
04/25/2025

DOC No.:
IFSE-0007

REV:
G

PAGE:
96 of 99

TITLE:
Air Conditioning System Installation Instructions For Continued
Airworthiness for Airbus Helicopters AS-350 B, C, D, D1, B1, B2, B3, BA &
EC-130 B4

APPENDIX A Weight and Balance

PERTAINS TO KIT #350-00-011
Weight (#) X Arm (") = Moment ("#)

ITEM	WEIGHT (#)	ARM (")	MOMENT ("#)
Forward Evaporator Assembly	13.50	19.00	256.50
Forward Air Outlets	.50	31.32	15.66
Aft Evaporator and Return Air	11.50	120.00	1380.00
Aft Evaporator Blower	5.00	120.85	604.25
Condenser Coil and Mount	19.50	133.80	2609.10
Condenser Blower and Mount	14.00	148.60	2080.40
Compressor and Mount	17.00	147.80	2512.60
Electrical Relay Panes	4.0	153.70	614.80
Refrigerant, Hoses and Fittings	7.50	76.90	576.75
<hr/>			
Sub Total: (Air Conditioner)	92.5		10650.06



DATE:
04/25/2025

DOC No.:
IFSE-0007

REV:
G

PAGE:
97 of 99

TITLE:
Air Conditioning System Installation Instructions For Continued
Airworthiness for Airbus Helicopters AS-350 B, C, D, D1, B1, B2, B3, BA &
EC-130 B4

PERTAINS TO KIT #350-00-031
Weight (#) X Arm (") = Moment ("#)

ITEM	WEIGHT (#)	ARM (")	MOMENT ("#)
Forward Evaporator Assembly	13.50	19.00	256.50
Forward Air Outlets	.50	31.32	15.66
Aft Evaporator and Return Air	11.50	120.00	1380.00
Aft Evaporator Blower	5.00	120.85	604.25
Condenser Assy. & Mount w/ Dual condenser blowers and closeout panel	40.00	201.80	8072.00
Compressor and Mount	17.00	147.80	2512.60
Electrical Relay Panes	4.0	153.70	614.80
Refrigerant, Hoses and Fittings	7.50	76.90	576.75
Sub Total: (Air Conditioner)	99.00		14032.56



DATE:
04/25/2025

DOC No.:
IFSE-0007

REV:
G

PAGE:
98 of 99

TITLE:
Air Conditioning System Installation Instructions For Continued
Airworthiness for Airbus Helicopters AS-350 B, C, D, D1, B1, B2, B3, BA &
EC-130 B4

PERTAINS TO KIT # 130-00-031
Weight (#) X Arm (") = Moment ("#)

ITEM	WEIGHT (#)	ARM (")	MOMENT ("#)
FWD. EVAP ASSY W/ MOTOR	14.0	24.0	336
FWD AIR OUTLETS (x2) W/ DUCTING	3.0	33.29	99.87
AFT EVAP W/ MOTOR & DUCTS	16.0	120.5	1928
CONDENSER ASSY W/ MOTOR & AIR DISCHARGE	33.0	223.3	7368.9
COMPRESSOR W/ MOUNTING KIT	17.5	147.8	2586.5
ELECTRICAL CONTROL BOX	4.0	153.7	614.8
REFRIGERANT HOSES	5.0	76.9	384.5
ELECTRICAL HARNESS	3.5	70.0	245
INSTALLATION TOTALS	96.0		13563.57